

APPENDIX H

VDOT Road and Bridge Standards Excerpts And Insertable Sheets

EC-1	Culvert Outlet Protection
EC-2	Protective Covering Installation Criteria
EC-3	Soil Stabilization Mat - 3 of 3
EC-4	Rock Check Dams I and II
EC-5	Temporary Silt Fence and Filter Barrier
EC-6	Drop Inlet Silt Trap – 2 of 2
EC-7	Typical Sediment Trap
EC-8	Dewatering Basin
EC-9	Temporary Diversion Dike
EC-10	Temporary Berm & Slope Drain
EC-11	Stabilized Construction Entrance
EC-12	Temporary Diversion Channel
EC-13	Riprap Weirs
EC-14	Temporary Vehicular Watercourse Crossing
L-3	Bench Planting On Rock Cut Section
L-3A	Horizontal Grooving Cut Slopes
PG-2A	Standard Paved Ditches
PG-3	Standard Riprap Ditch and Slope Protection
PG-5	Standard Paved Ditches
SWM-1	SWM Drainage Structure - 2 of 2
SWM-DR	Stormwater Management Details – 5 of 5
	Roadside Development
	Erosion Control Summary
	Temporary Sediment Trap Detail Sheet
	Sinkhole Treatment Details
	SWPPP sheets 3of 3

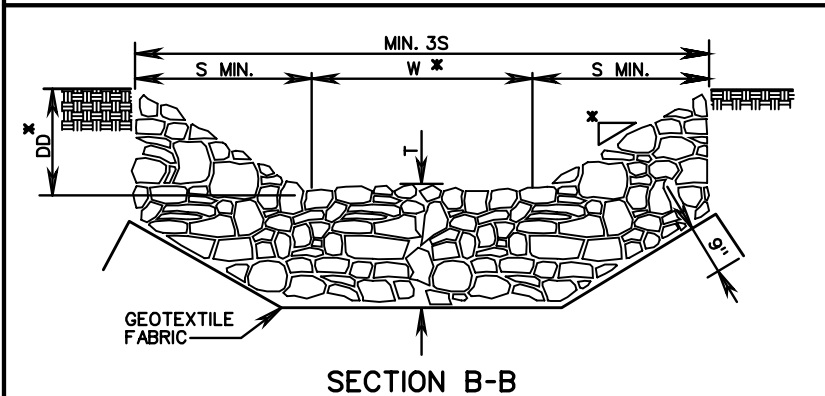
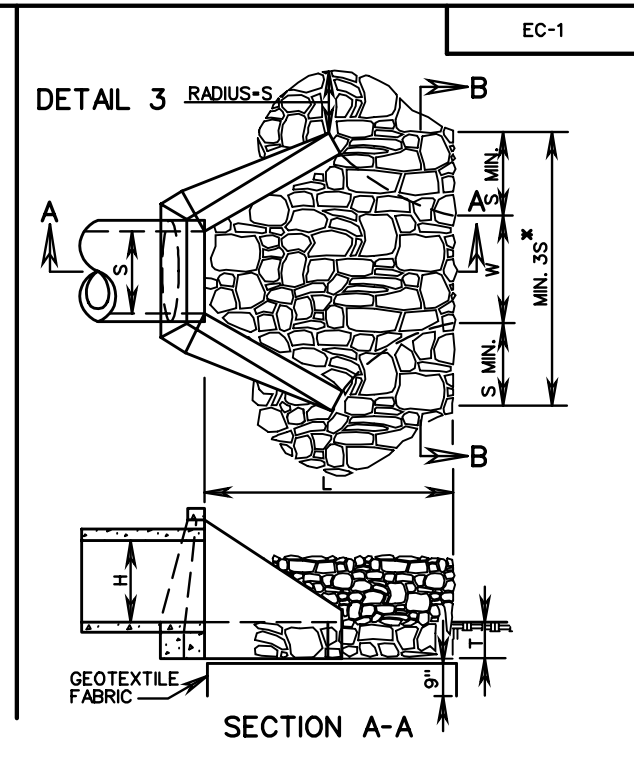
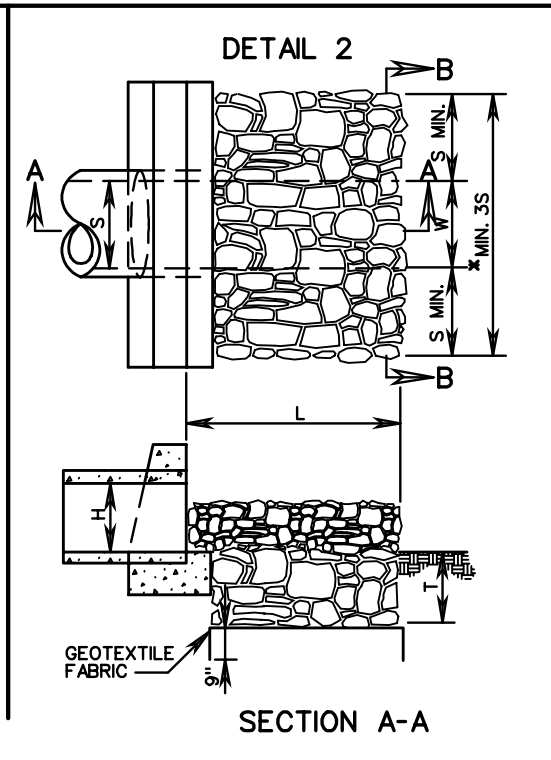
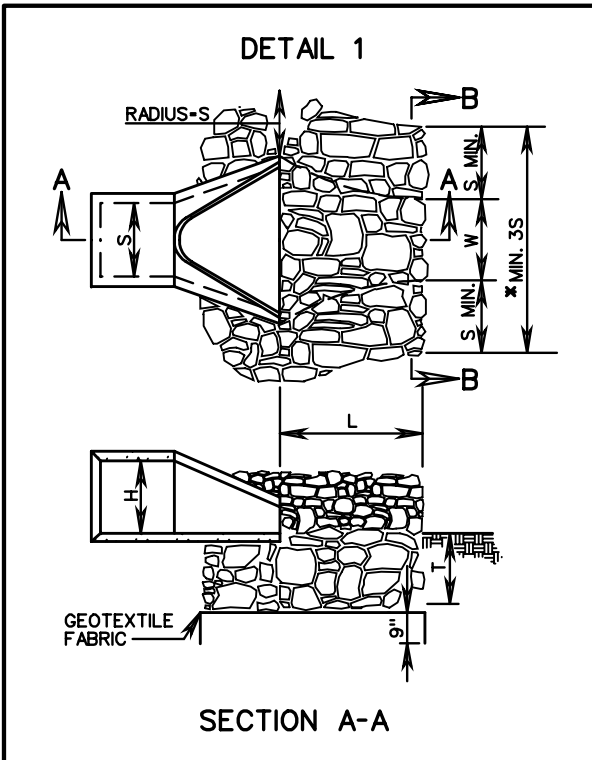

NOTES:

1. FOR MULTIPLE LINE INSTALLATIONS, DIMENSION S IS TO GOVERN THE PROTECTION OUTSIDE THE CHANNEL WIDTH (W).
 2. ON ANY INSTALLATION REQUIRING CULVERT OUTLET PROTECTION WHERE NO ENDWALL OR ENDSECTION IS SPECIFIED ON THE PLANS, CONSTRUCTION IS TO BE IN ACCORDANCE WITH DETAIL 2 SHOWN ABOVE.
 3. GEOTEXTILE FABRIC TO BE INSTALLED UNDER CLASS A1, I, AND II MATERIALS IN ACCORDANCE WITH THE SPECIFICATIONS.
 4. S = DIAMETER OF CIRCULAR CULVERT OR SPAN FOR BOX, ELLIPTICAL OR ARCH CULVERT. H = DIAMETER OF CIRCULAR CULVERT OR RISE/HEIGHT FOR BOX, ELLIPTICAL OR ARCH CULVERT.
- * USE TYPICAL SECTION SHOWN ON PLANS FOR SIDE SLOPE, BOTTOM WIDTH AND DEPTH OF CHANNEL OR MATCH EXISTING DITCH OR NATURAL GROUND.

TYPE OF OUTLET PROTECTION MATERIAL		MAXIMUM OUTLET VELOCITY (FOR DESIGN STORM)	MINIMUM "T" (INCHES)
CLASS A1	CLASS A1 DRY RIPRAP	8 fps	18
CLASS I	CLASS I DRY RIPRAP	14 fps	24
CLASS II	CLASS II DRY RIPRAP	19 fps	36

OUTLET PROTECTION MINIMUM LENGTH (L)	
TYPE A INSTALLATION	3H
TYPE B INSTALLATION	5H

SPECIFICATION REFERENCE
204
245
303
414

CULVERT OUTLET PROTECTION

VIRGINIA DEPARTMENT OF TRANSPORTATION

VDOT ROAD AND BRIDGE STANDARDS	
REVISION DATE	SHEET 1 OF 1
113.01	

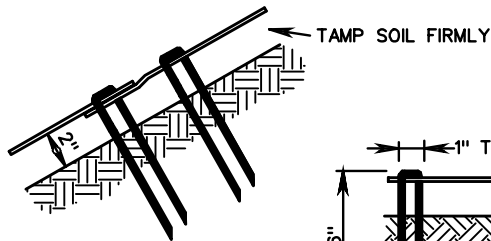
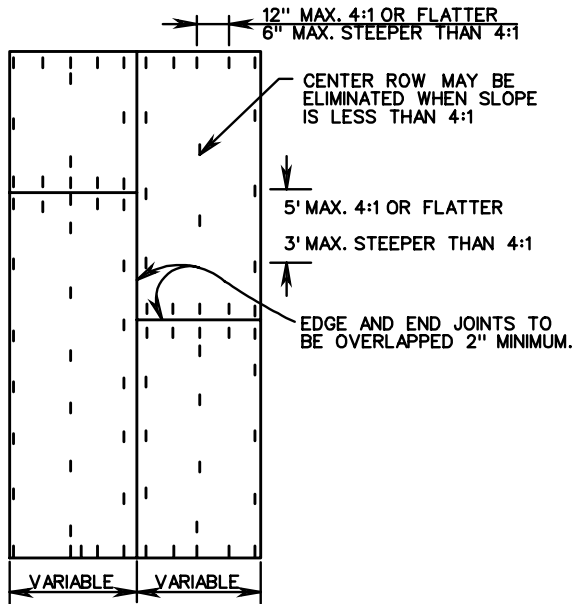

JUNCTION SLOT

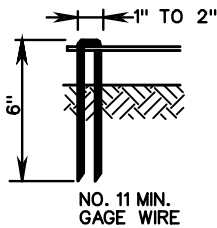

SOIL RETENTION MAT

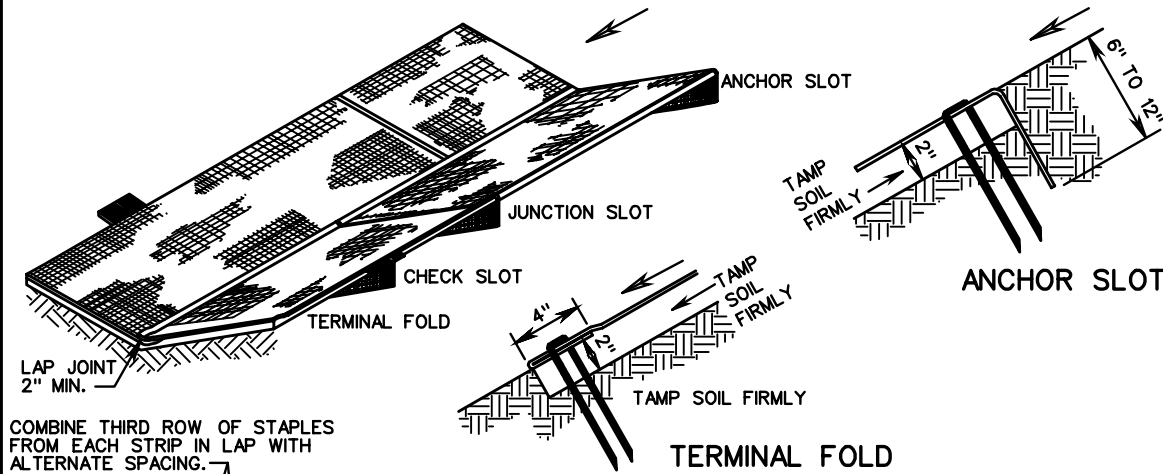

COMBINE THIRD ROW OF STAPLES FROM EACH STRIP IN LAP WITH ALTERNATE SPACING.

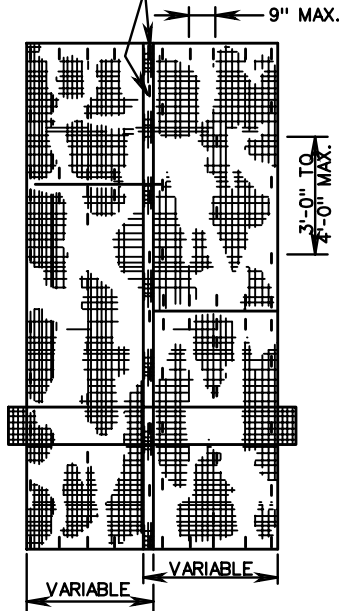

PLAN VIEW STAPLING DIAGRAM

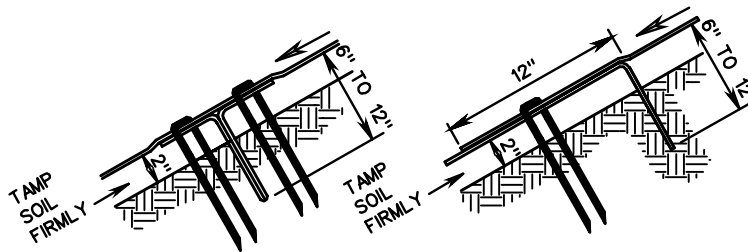

CHECK SLOT

JUNCTION SLOT

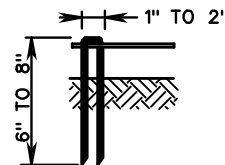

JUTE MESH

NOTES:

1. APPROXIMATE 200 STAPLES REQUIRED PER 4' X 225' ROLL.
2. ANCHOR SLOTS, JUNCTION SLOTS AND CHECK SLOTS TO BE BURIED 6" TO 12" AND VARIABLE.
3. MAX. SPACING C-C CHECK SLOTS 100' SLOPE 4% OR LESS 50' SLOPE STEEPER THAN 4%.
4. STAPLES FORMED FROM NO. 8 STEEL WIRE 8" STAPLE MINIMUM LENGTH FOR SANDY SOIL 6" STAPLE MINIMUM LENGTH FOR OTHER SOIL.

GENERAL NOTES:

1. BASIS OF PAYMENT TO BE SQUARE YARDS OF PROTECTIVE COVERING COMPLETE IN PLACE. PROTECTIVE COVERING IS TO BE LOCATED AS INDICATED ON THE PLANS IN ACCORDANCE WITH THE DIMENSIONS SPECIFIED ON TYPICAL SECTION.
2. "T-TOP" STAPLES OR OTHER MANUFACTURER'S DESIGN APPROVED BY THE ENGINEER MAY BE SUBSTITUTED FOR THE STAPLES SHOWN.
3. JUTE MESH OR SOIL RETENTION MAT IN ACCORDANCE WITH THE SPECIFICATIONS MAY BE USED AT THE OPTION OF THE CONTRACTOR.
4. WIDTH OF MATERIAL MAY VARY FROM MINIMUM DIMENSION BY INCREMENTS OF 4 OR 5 FEET.
5. FOR SOURCES OF APPROVED MATERIAL SEE VDOT'S APPROVED PRODUCTS LIST FOR ST'D. EC-2 MATERIAL.



ROAD AND BRIDGE STANDARDS

SHEET 1 OF 1

REVISION DATE

113.02

PROTECTIVE COVERING INSTALLATION CRITERIA

VIRGINIA DEPARTMENT OF TRANSPORTATION

SPECIFICATION REFERENCE

244
606

TYPICAL INSTALLATION AT END OF PIPE

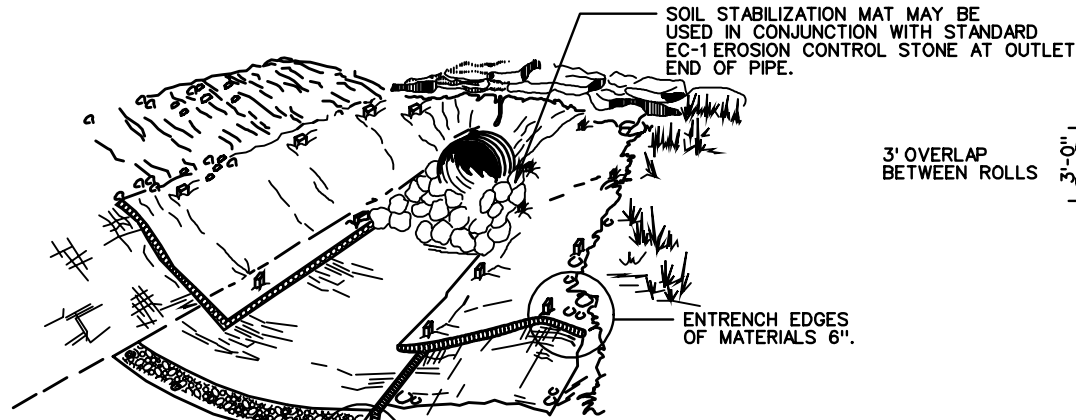

STAKING DETAIL

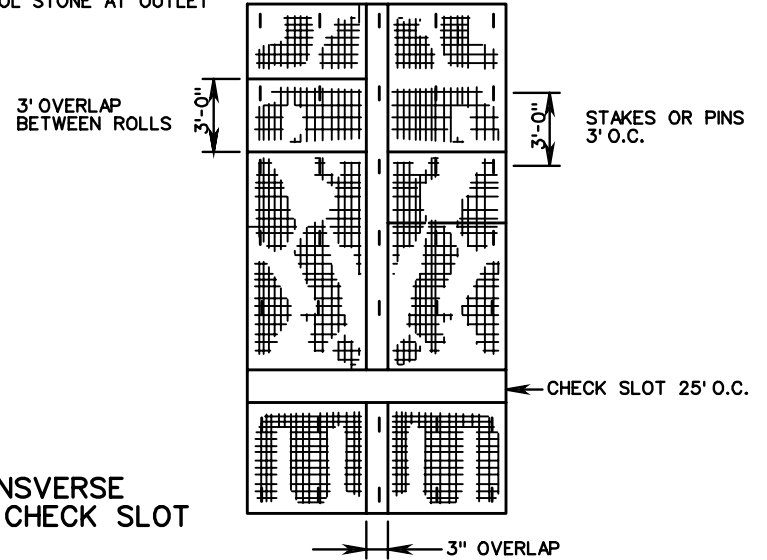

* TRANSVERSE CLOSED CHECK SLOT

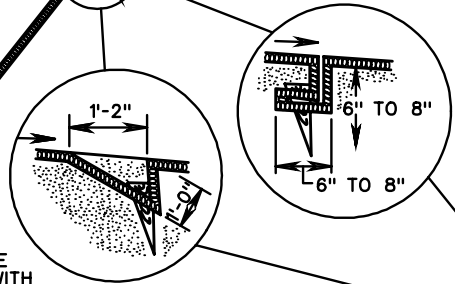

* TRANSVERSE CHECK SLOT TO BE CONSTRUCTED IN ACCORDANCE WITH THE MANUFACTURER'S RECOMMENDATION FOR PREFERRED INSTALLATION.

* TRANSVERSE OPEN CHECK SLOT

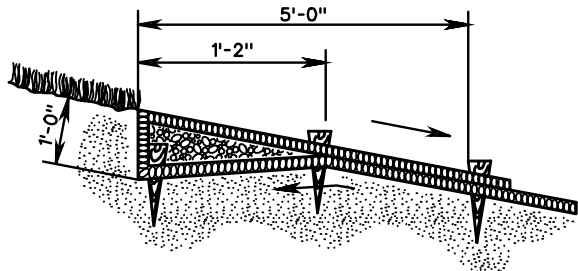

UPSTREAM AND DOWNSTREAM TERMINAL

V DITCH

NOTES:

1. STAKES SHALL BE WOOD OR METAL AS RECOMMENDED BY THE MANUFACTURER AND SHALL BE A MINIMUM OF 12" IN LENGTH. IN SANDY SOILS METAL STAKES A MINIMUM OF 18" IN LENGTH SHALL BE USED.
2. SOIL STABILIZATION MAT TYPE A AND B ARE TO BE IN ACCORDANCE WITH THE APPROVED PRODUCTS LIST.
3. SOIL STABILIZATION MAT SHOULD BE INSTALLED TO THE SHOULDER BREAK POINT OR EXISTING GROUND THEN EMBEDDED 6". MATERIAL ON BOTH SIDES OF THE DITCH SHALL BE INSTALLED TO THE SAME ELEVATIONS.
4. IF MORE THAN 3 LINES OF MATERIAL ARE REQUIRED PARALLEL TO THE C OF THE DITCH, MATERIAL SHALL BE INSTALLED PERPENDICULAR TO THE CENTER LINE OF THE DITCH, STARTING AT THE LOWEST C ELEVATION OF THE DITCH.
5. FOR SOURCES OF APPROVED MATERIALS SEE VDOT'S APPROVED PRODUCTS LIST FOR ST'D. EC-3, TYPE A OR B.

SPECIFICATION REFERENCE

244
606

SOIL STABILIZATION MAT
DITCH INSTALLATION TYPE A OR B

VIRGINIA DEPARTMENT OF TRANSPORTATION

VDOT

ROAD AND BRIDGE STANDARDS

REVISION DATE

SHEET 1 OF 3

113.03

DETAIL 1

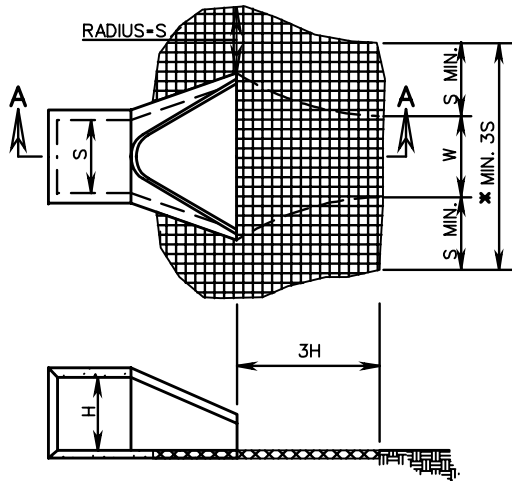

SECTION A-A

DETAIL 2

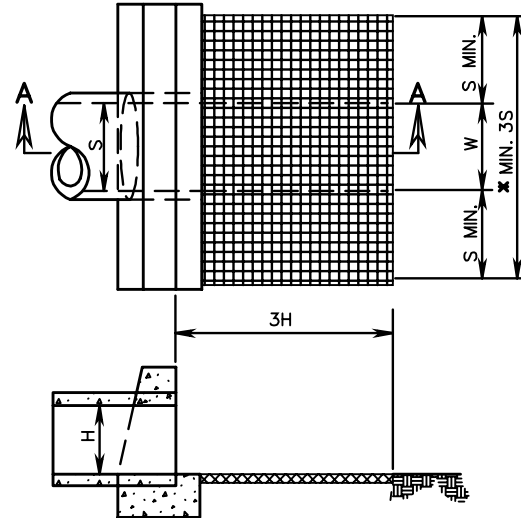

SECTION A-A

NOTES:

1. FOR MULTIPLE LINE INSTALLATIONS, DIMENSION S IS TO GOVERN THE PROTECTION OUTSIDE THE CHANNEL WIDTH (W).
 2. ON ANY INSTALLATION REQUIRING CULVERT OUTLET PROTECTION WHERE NO ENDWALL OR ENDSECTION IS SPECIFIED ON THE PLANS, CONSTRUCTION IS TO BE IN ACCORDANCE WITH DETAIL 2 SHOWN ABOVE.
 3. SOIL STABILIZATION MAT TYPE B SHALL BE USED FOR CULVERT OUTLET PROTECTION WHERE THE OUTLET VELOCITY IS 6 FPS OR LESS FOR THE DESIGN STORM AND THE TOTAL HYDRAULIC OPENING IS LESS THAN 7 SQUARE FEET. IF THE TOTAL HYDRAULIC OPENING IS 7 SQUARE FEET OR GREATER, OR THE DESIGN STORM OUTLET VELOCITY IS GREATER THAN 6 FPS USE STANDARD EC-1.
 4. S = DIAMETER OF CIRCULAR CULVERT OR SPAN FOR BOX, ELLIPTICAL OR ARCH CULVERT.
 H = DIAMETER OF CIRCULAR CULVERT OR RISE/HEIGHT FOR BOX, ELLIPTICAL OR ARCH CULVERT.
- * USE TYPICAL SECTION SHOWN ON PLANS FOR SIDE SLOPE, BOTTOM WIDTH AND DEPTH OF CHANNEL OR MATCH EXISTING DITCH OR NATURAL GROUND.



ROAD AND BRIDGE STANDARDS

SHEET 2 OF 3

REVISION DATE

113.04

SOIL STABILIZATION MAT CULVERT OUTLET PROTECTION INSTALLATION

VIRGINIA DEPARTMENT OF TRANSPORTATION

SPECIFICATION
REFERENCE

204
245
303
414

FILL SLOPE SECTION

DROP STD EC-3 MATERIAL VERTICALLY DOWNSLOPE

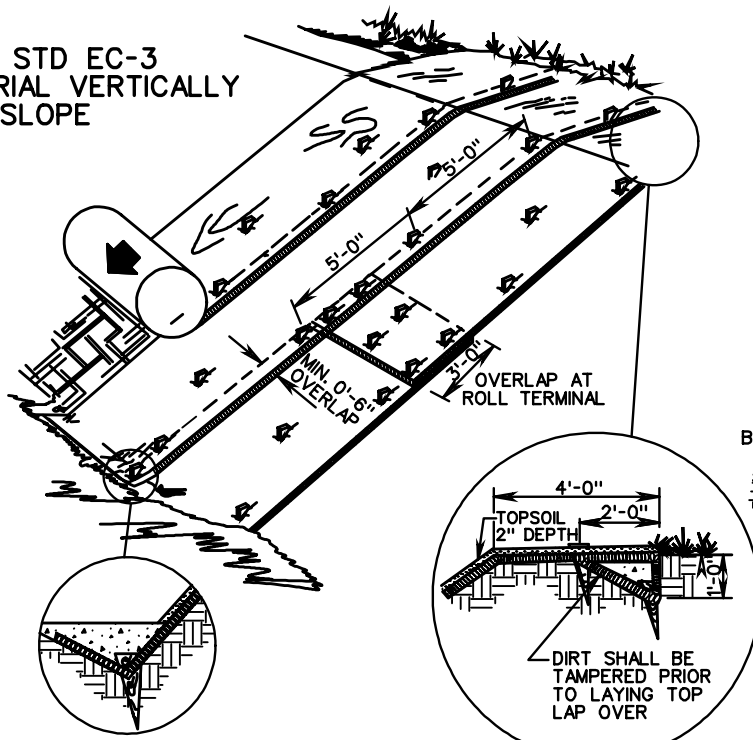

TOE OF FILL

MAINTAIN SLOPE ANGLE

BERM

TRENCH INTO BERM AND PROGRESS DOWNSLOPE

SLOPE LINING - WET SLOPE

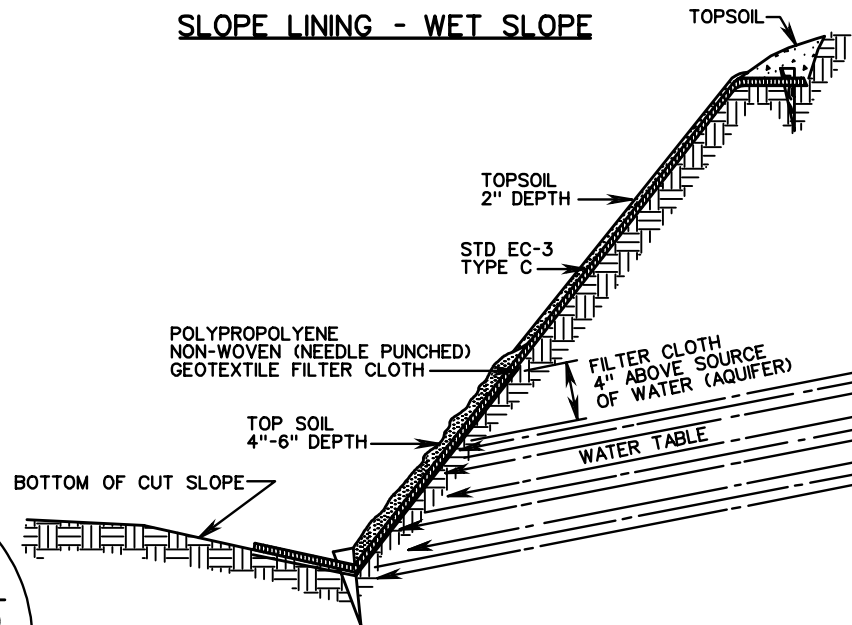

SLOPE LINING - DRY SLOPE

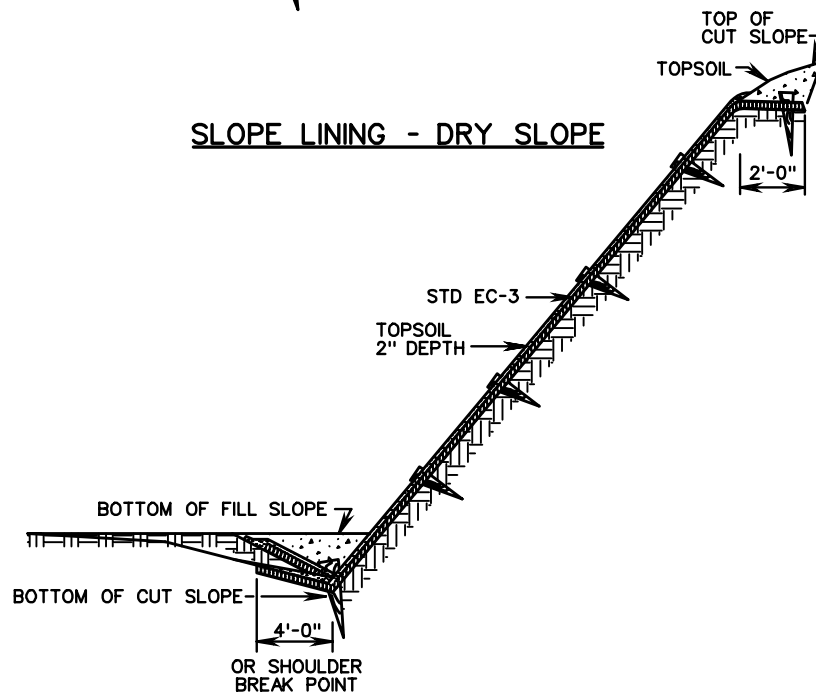

NOTE:

1. SLOPE SURFACE SHALL BE SMOOTH AND FREE OF ROCKS, LUMPS OF DIRT, GRASS, AND STICKS. MAT SHALL BE PLACED FLAT ON SURFACE FOR PROPER SOIL CONTACT.
2. STAKES SHALL BE WOOD OR METAL AS RECOMMENDED BY THE MANUFACTURER AND SHALL BE A MINIMUM OF 18 INCHES IN LENGTH.
3. BASIS OF PAYMENT SHALL BE SQUARE YARDS OF STANDARD EC-3 (TYPE C) IN PLACE.
4. SOIL STABILIZATION MAT TYPE C SHALL BE IN ACCORDANCE WITH THE APPROVED PRODUCT LIST.
5. TOPSOIL SHALL BE SPREAD TO A UNIFORM THICKNESS PRIOR TO APPLICATION OF SEED AND MULCH.
6. FOR SOURCES OF APPROVED MATERIALS SEE VDOT'S APPROVED PRODUCTS LIST FOR ST'D. EC-3, TYPE C MATERIALS.
7. SLOPES 1/2:1 AND FLATTER SHALL BE BACKFILLED WITH TOPSOIL AT 2 INCH DEPTH. SEED SHALL BE APPLIED TO THE TOPSOIL AND MULCHED WITH TYPE I MULCH.
8. SLOPES STEEPER THAN 1/2:1 SHALL BE SEEDED IMMEDIATELY PRIOR TO INSTALLATION OF ST'D. EC-3 TYPE C MATERIAL.

SPECIFICATION REFERENCE

244
606

SOIL STABILIZATION MAT - SLOPE INSTALLATION TYPE C

VIRGINIA DEPARTMENT OF TRANSPORTATION

VDOT

ROAD AND BRIDGE STANDARDS

REVISION DATE

SHEET 3 OF 3

113.05

TYPICAL DETAIL FOR ROCK CHECK DAM TYPE I

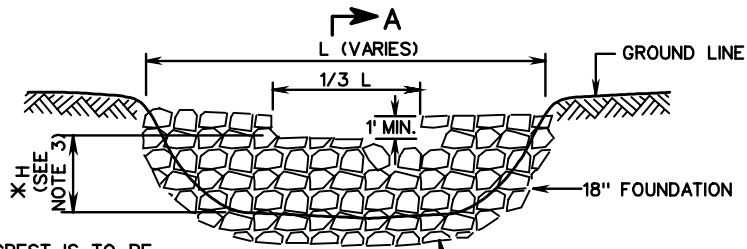

* HEIGHT (H) OF CREST IS TO BE 3'± IF CHANNEL OR SWALE IS DEEP ENOUGH OR AS DESIGNATED BY DESIGNER.

FRONT ELEVATION

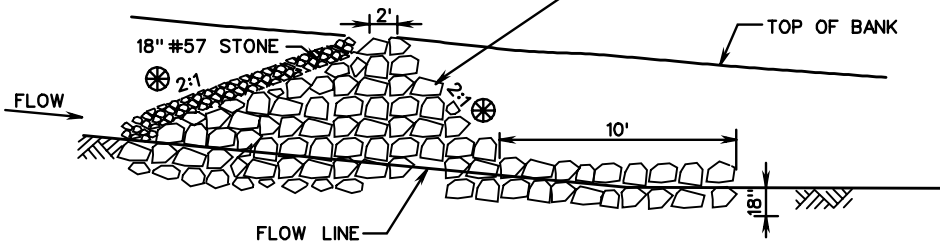

SECTION A-A

TYPICAL DETAIL FOR ROCK CHECK DAM TYPE II

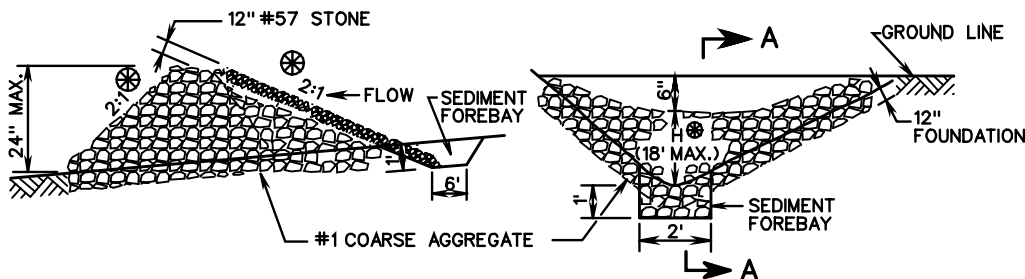

SECTION A-A

FRONT ELEVATION

SUGGESTED ROCK CHECK DAM SPACING

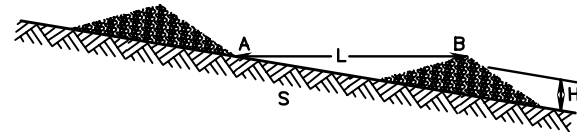

L = H/S WHERE:
 H - HEIGHT OF DAM CREST IN FEET
 S - CHANNEL SLOPE IN FT/FT
 L - CHECK DAM SPACING IN FEET; THE DISTANCE SUCH THAT POINTS A AND B ARE OF EQUAL ELEVATION

CHECK DAM SPACING, L TO BE DETERMINED FROM THE EQUATION. IN STEEP SLOPE AREAS THE CHECK DAM SPACING IS NOT TO BE LESS THAN 25'.

NOTES:

1. ROCK CHECK DAMS THAT ARE DESIGNATED ON THE PLANS AS A STORMWATER MANAGEMENT (SWM) ITEM ARE TO BE LEFT IN PLACE AS A PERMANENT INSTALLATION.
2. WHERE DRAINAGE AREAS EXCEED 1 ACRE OR DITCH GRADE EXCEEDS 3%, A TEMPORARY SEDIMENT FOREBAY SHALL BE INSTALLED WITH MINIMUM DIMENSIONS OF 12" DEPTH, 2' WIDTH AND 6' LENGTH.
3. IF CHECK DAMS IS LOCATED INSIDE CLEAR ZONE AND ADJACENT TO A TRAVELWAY, SLOPE FACING ON COMING TRAFFIC IS TO BE 6:1 AND MAXIMUM H IS TO BE 12".
4. ALTERNATIVE MATERIALS ON VDOT'S SPEL LIST MAY BE SUBSTITUTED AT NO ADDITIONAL COST TO THE DEPARTMENT.
5. SEE STANDARD EC-5 FOR DETAILS FOR ROCK CHECK DAMS IN ROADSIDE DITCHES
6. CHECK DAM SHALL NOT BE USED FOR LOCATIONS IN LIVE STREAM.

**SILT BARRIERS
TYPICAL DETAIL FOR BRUSH BARRIER
(TO BE USED AT ALL APPLICABLE LOCATIONS)**

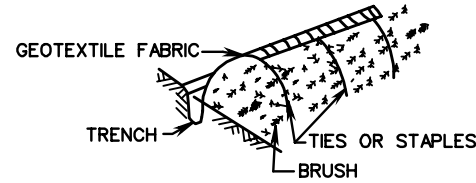
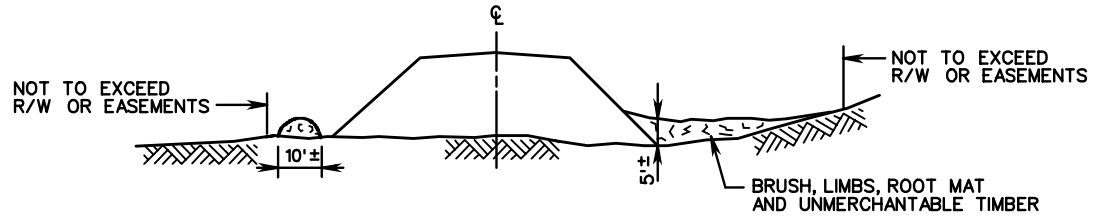
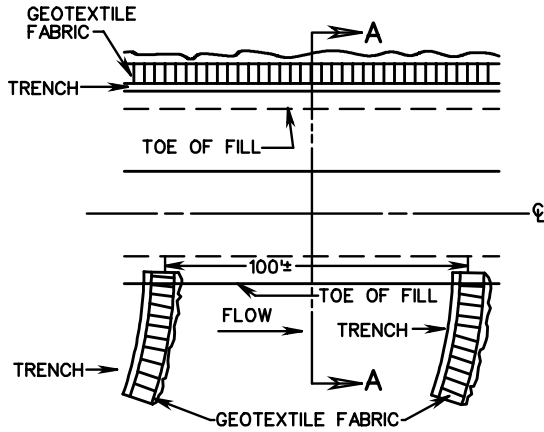

BACK ISOMETRIC

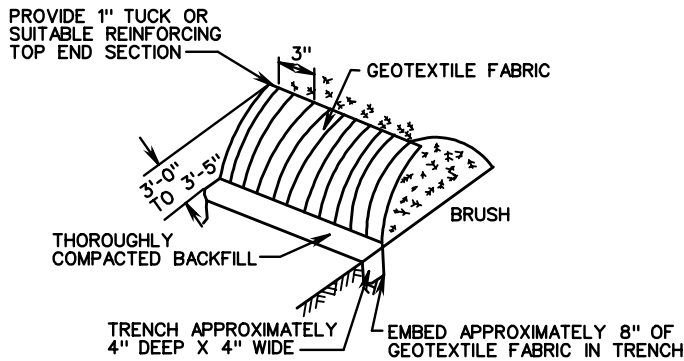

FRONT ISOMETRIC

NOTES:

1. BRUSH BARRIERS SHALL BE CONSTRUCTED AT LOCATION SHOWN ON THE PLANS OR AS DIRECTED BY THE ENGINEER. BRUSH SHALL BE PILED AGAINST EXISTING TREES TO PREVENT MOVEMENT OF BARRIER. BRUSH SHALL BE PILED AS TIGHTLY AS POSSIBLE AND WEIGHTED DOWN BY UNMERCHANTABLE LOGS.
2. GEOTEXTILE FABRIC CONFORMING TO THE ROAD AND BRIDGE SPECIFICATIONS SHALL BE INSTALLED AS DETAILED ABOVE. GEOTEXTILE FABRIC MAY ALSO BE ATTACHED TO EXISTING FENCES WHEN SPECIFIED ON THE PLANS OR DIRECTED BY THE ENGINEER.
3. NO BRUSH WILL BE DESTROYED OR REMOVED FROM THE PROJECT UNTIL ALL BRUSH SILT BARRIERS ARE IN PLACE AND HAVE BEEN INSPECTED AND APPROVED BY THE ENGINEER.
4. DIMENSIONS SHOWN ARE APPROXIMATE ONLY.



ROAD AND BRIDGE STANDARDS

SHEET 2 OF 2

REVISION DATE

113.08

**TEMPORARY SILT BARRIERS
FILTER BARRIER, SILT FENCE, AND BRUSH BARRIER
VIRGINIA DEPARTMENT OF TRANSPORTATION**

SPECIFICATION
REFERENCE

107
303

INLET PROTECTION (TYPE A)

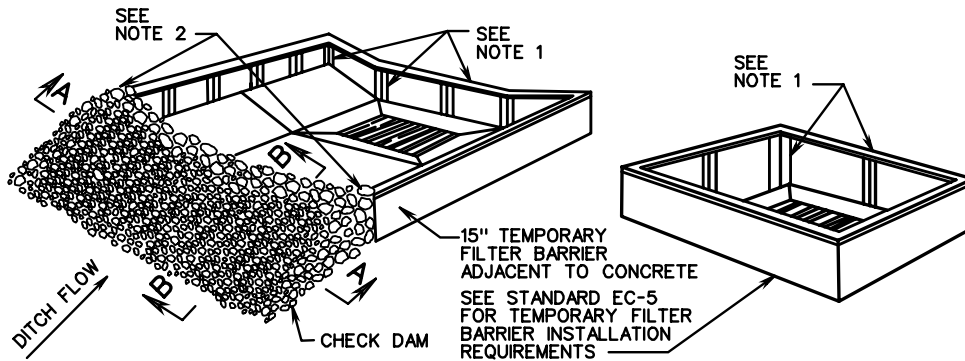

TYPICAL TREATMENT FOR DROP INLET WITH CONCRETE GUTTER

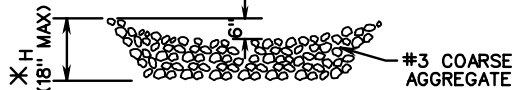

SECTION A-A

* IF CHECK DAM IS LOCATED INSIDE CLEAR ZONE AND ADJACENT TO A TRAVELWAY, SLOPE FACING ON COMING TRAFFIC IS TO BE 6:1 AND MAXIMUM H IS TO BE 12".

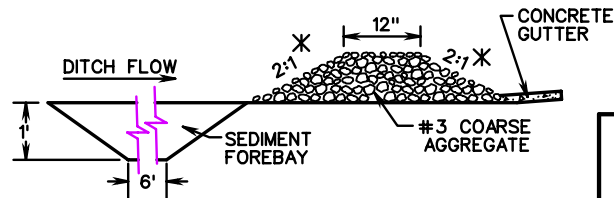

SECTION B-B

NOTES

1. POSTS AND TOP RAIL SHALL BE A NOMINAL 2 1/2" X 2 1/2" OR A 3" DIA. NO. 2 SOUTHERN PINE, A NOMINAL 2" X 2" OAK, OR STEEL HAVING A MIN. WEIGHT OF 1.25 LBS. PER LINEAR FOOT AND A MIN. LENGTH OF 5' FOR TEMPORARY SILT FENCES.
2. END OF FILTER BARRIER TO BE EMBEDDED INTO AGGREGATE.
3. IF A DROP INLET IS LOCATED IN A SAG IN THE DITCH GRADE, A CHECK DAM IS REQUIRED FOR EACH SIDE OF THE INLET THAT RECEIVES DITCH FLOW.
4. WHERE DRAINAGE AREAS EXCEED ONE ACRE OR DITCH GRADE EXCEEDS 3%, A TEMPORARY SEDIMENT FOREBAY SHALL BE INSTALLED WITH MINIMUM DIMENSIONS OF 12" DEPTH, 2' WIDTH AND 6' LENGTH.

TYPICAL TREATMENT FOR DROP INLET WITHOUT CONCRETE GUTTER

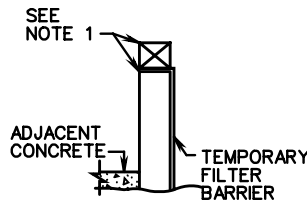

INLET PROTECTION (TYPE B)

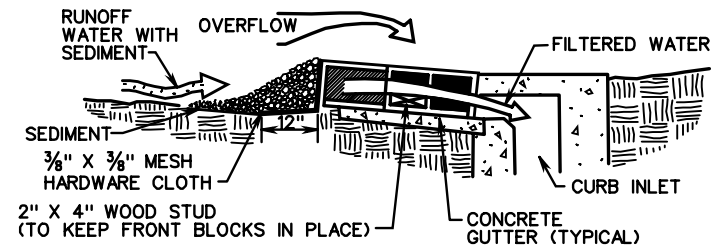
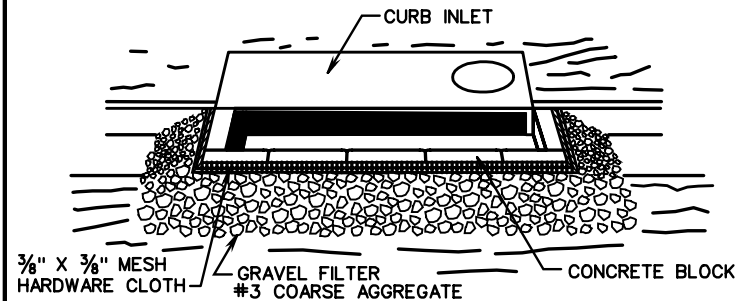

SECTION VIEW

SPECIFIC APPLICATION

THIS METHOD OF INLET PROTECTION IS APPLICABLE AT CURB INLETS WHERE AN OVERFLOW CAPABILITY IS NECESSARY TO PREVENT EXCESSIVE PONDING IN FRONT OF THE STRUCTURE.

NOTE:

GEOTEXTILE PRODUCTS DESIGNED TO BE INSERTED INTO GRATED DROP INLETS OR DESIGNED TO COVER THE SLOTS OF SLOT DROP INLETS, THAT HAVE BEEN APPROVED FOR USE ON VDOT PROJECTS AND ARE FOUND ON VDOT'S SPEL LIST, MAY BE SUBSTITUTED FOR THE DROP INLET PROTECTION DEVICES DETAILED HEREON.

SPECIFICATION REFERENCE

107
242
303

INLET PROTECTION (TYPE A AND B)

VIRGINIA DEPARTMENT OF TRANSPORTATION

VDOT

ROAD AND BRIDGE STANDARDS

REVISION DATE

SHEET 1 OF 2

113.09

TYPICAL DETAIL FOR INSTALLATION OF TEMPORARY FILTER BARRIER/SILT FENCE/CHECK DAM AT CULVERT

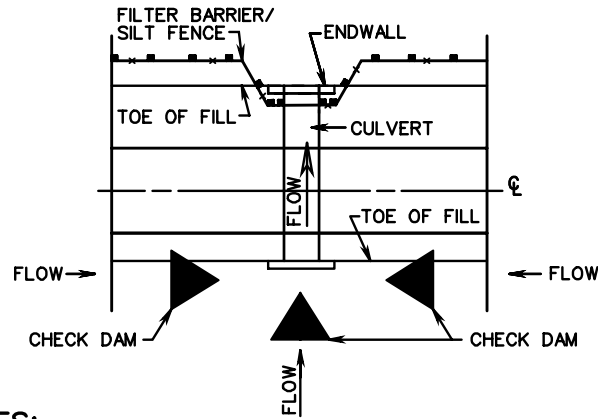

NOTES:

1. IF ANY PORTION OF FILL IS GREATER THAN 5', SILT FENCE IS REQUIRED. IF FILL HEIGHT IS LESS THAN 5', FILTER BARRIER IS REQUIRED.
2. ROCK CHECK DAM IS TO BE CONSTRUCTED IN ACCORDANCE WITH THE ROAD AND BRIDGE SPECIFICATIONS, AND STANDARD EC-4.
3. FILTER BARRIER/SILT FENCE IS TO BE INSTALLED IN ACCORDANCE WITH THE ROAD AND BRIDGE SPECIFICATIONS, AND STANDARD EC-5.

* INSTALLATION DETAIL ONLY - ROCK CHECK DAMS, FILTER BARRIER, AND SILT FENCE TO BE PAID FOR IN ACCORDANCE WITH THE ROAD AND BRIDGE SPECIFICATIONS.



ROAD AND BRIDGE STANDARDS

SHEET 2 OF 2

REVISION DATE

113.10

INLET PROTECTION
(TYPE C)

VIRGINIA DEPARTMENT OF TRANSPORTATION

SPECIFICATION
REFERENCE

107
242
303

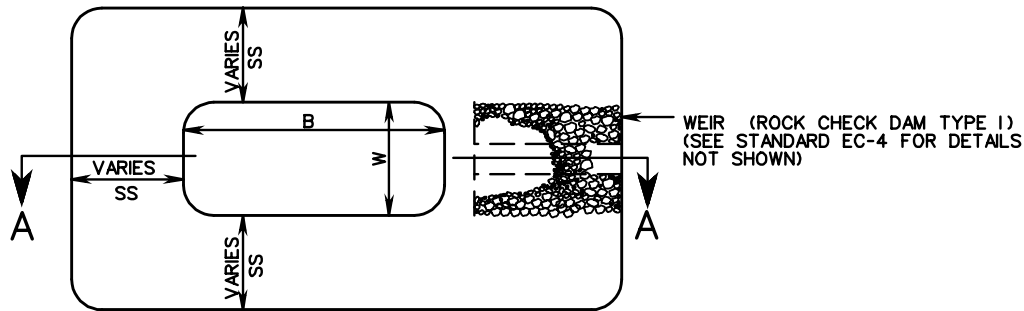

PLAN VIEW OF TEMPORARY SEDIMENT TRAP

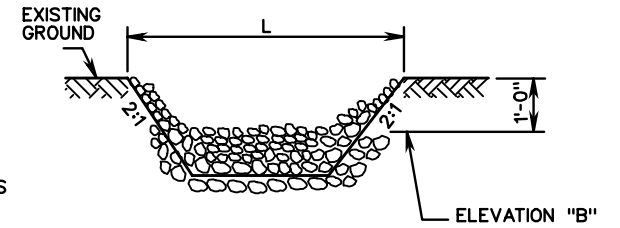

TYPICAL SECTION THRU WEIR
(ROCK CHECK DAM TYPE 1)

NOTES:

1. CHECK DAM IS SHOWN FOR ILLUSTRATION ONLY AND IS NOT INCLUDED IN PAYMENT FOR SEDIMENT TRAP.
2. THE SEDIMENT STORAGE VOLUME SHALL BE 134 CUBIC YARDS/ACRE OF TOTAL CONTRIBUTING DRAINAGE AREA AND SHALL CONSIST OF HALF IN THE FORM OF WET STORAGE AND HALF IN THE FORM OF DRY STORAGE.
3. SEE PLANS FOR DIMENSIONS AND ELEVATIONS.

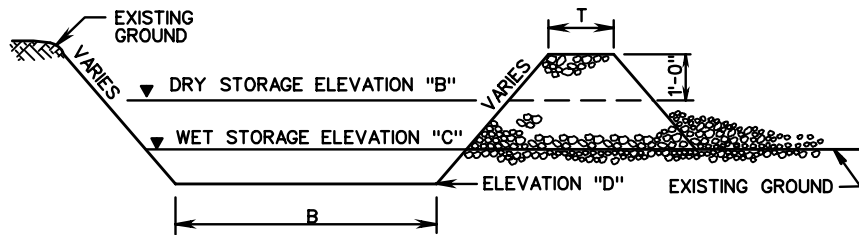

TYPICAL SECTION (A-A) THRU
TEMPORARY SEDIMENT TRAP

SPECIFICATION
REFERENCE

107
303

TYPICAL SEDIMENT TRAP

VIRGINIA DEPARTMENT OF TRANSPORTATION

VDOT

ROAD AND BRIDGE STANDARDS

REVISION DATE

SHEET 1 OF 1

113.11

TYPICAL DEWATERING BASIN

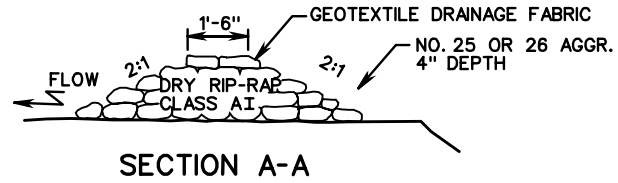
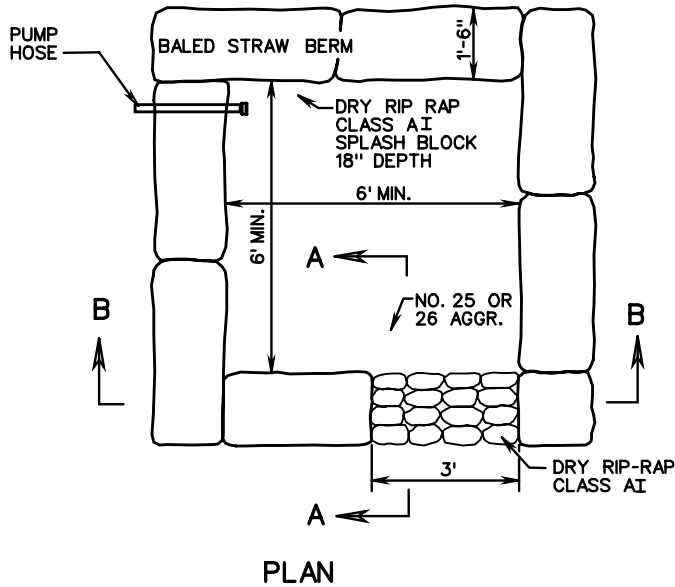

* GEOTEXTILE DRAINAGE FABRIC TO COVER INSIDE FACE OF BALED STRAW BERM.

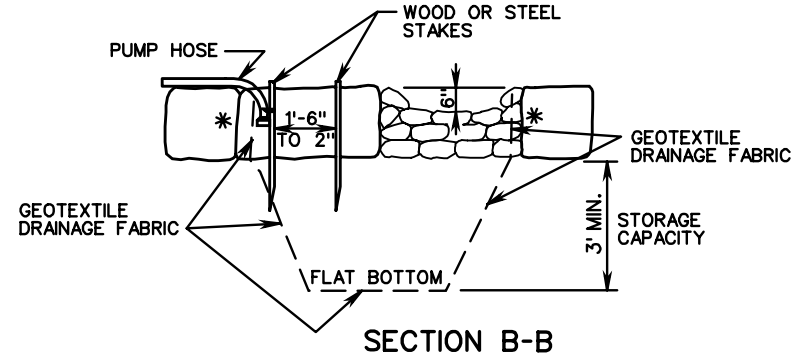

NOTES:

1. DEWATERING BASIN SIZE SHALL BE DETERMINED BY THE FORMULA $16 \times \text{GAL./MIN. OF PUMP} = \text{CU. FT. OF STORAGE CAPACITY}$.
2. THIS WORK SHALL CONSIST OF THE CONSTRUCTION OF A DEWATERING BASIN FOR THE PURPOSE OF RECEIVING SEDIMENT-LADENED WATER PUMPED FROM A CONSTRUCTION SITE TO ALLOW FOR FILTRATION BEFORE IT REENTERS THE WATERWAY. PUMPING INTO THESE BASINS SHALL CEASE WHEN THE FLOW FROM THE BASIN BECOMES SEDIMENT-LADENED.
3. SURFACE WATER FLOW SHALL BE DIVERTED AROUND THIS DEVICE.
4. THE OUTFALL FROM THE BASIN(S) SHALL HAVE A STABILIZED CONVEYANCE TO RECEIVING WATERS.
5. ONCE THE DEWATERING BASIN BECOMES FILLED TO HALF OF THE STORAGE CAPACITY, ACCUMULATED SEDIMENT SHALL BE REMOVED AND DISPOSED OF IN AN APPROVED DISPOSAL AREA OUTSIDE OF THE 100-YEAR FLOODPLAIN UNLESS OTHERWISE APPROVED ON THE PLANS.
6. SEDIMENT CONTROL DEVICES ARE TO REMAIN IN PLACE UNTIL ALL DISTURBED AREAS ARE STABILIZED AND THE ENGINEER APPROVES THEIR REMOVAL. GROUND CONTOURS SHALL BE RETURNED TO THEIR ORIGINAL CONDITION UNLESS SPECIFICALLY APPROVED OTHERWISE BY THE ENGINEER.
7. SYNTHETIC PRODUCTS THAT HAVE BEEN APPROVED FOR USE ON VDOT PROJECTS AND FOUND ON VDOT'S SPEL LIST MAY BE USED IN LIEU OF THIS DESIGN. HOWEVER, VDOT WILL ONLY COMPENSATE THE CONTRACTOR UP TO THE BID PRICE PER EACH AT EACH SITE.

TYPICAL SYNTHETIC PRODUCT

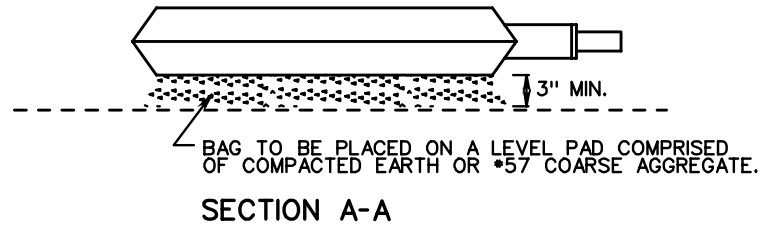

SECTION A-A

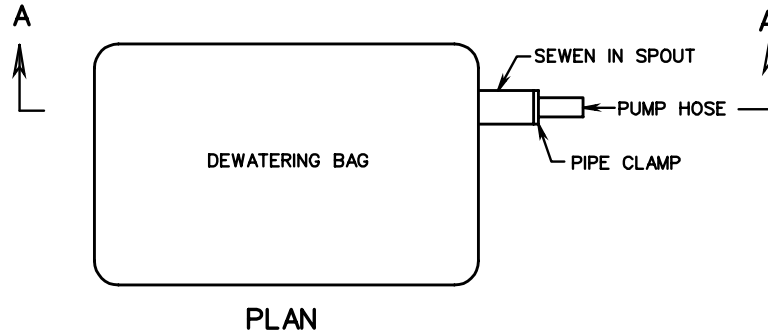

PLAN



ROAD AND BRIDGE STANDARDS

SHEET 1 OF 1

REVISION DATE

113.12

DEWATERING BASIN

VIRGINIA DEPARTMENT OF TRANSPORTATION

SPECIFICATION REFERENCE

107
303

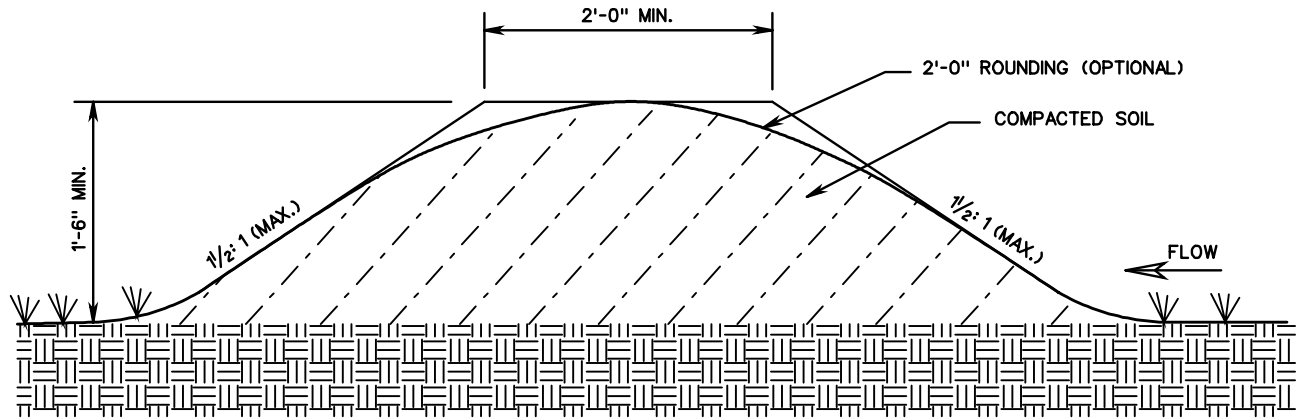

TEMPORARY DIVERSION DIKE

NOTE:

1. THE CHANNEL CREATED BEHIND THE DIKE SHALL HAVE A POSITIVE GRADE TO A STABILIZED OUTLET. THE CHANNEL SHALL BE STABILIZED, AS NECESSARY, TO PREVENT EROSION.
2. TEMPORARY DIVERSION DIKE WILL BE MEASURED AND PAID FOR IN ACCORDANCE WITH SECTION 303 OF THE SPECIFICATIONS.

<p>SPECIFICATION REFERENCE</p>	<h2>TEMPORARY DIVERSION DIKE</h2>	<p>VDOT ROAD AND BRIDGE STANDARDS</p>				
<p>303</p>	<p>VIRGINIA DEPARTMENT OF TRANSPORTATION</p>	<table border="1" style="width: 100%;"> <tr> <td style="width: 50%;">REVISION DATE</td> <td style="width: 50%;">SHEET 1 OF 1</td> </tr> <tr> <td colspan="2" style="text-align: center;">113.13</td> </tr> </table>	REVISION DATE	SHEET 1 OF 1	113.13	
REVISION DATE	SHEET 1 OF 1					
113.13						

TEMPORARY BERM & SLOPE DRAIN

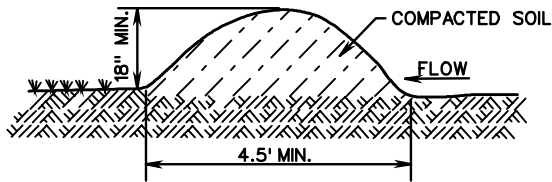
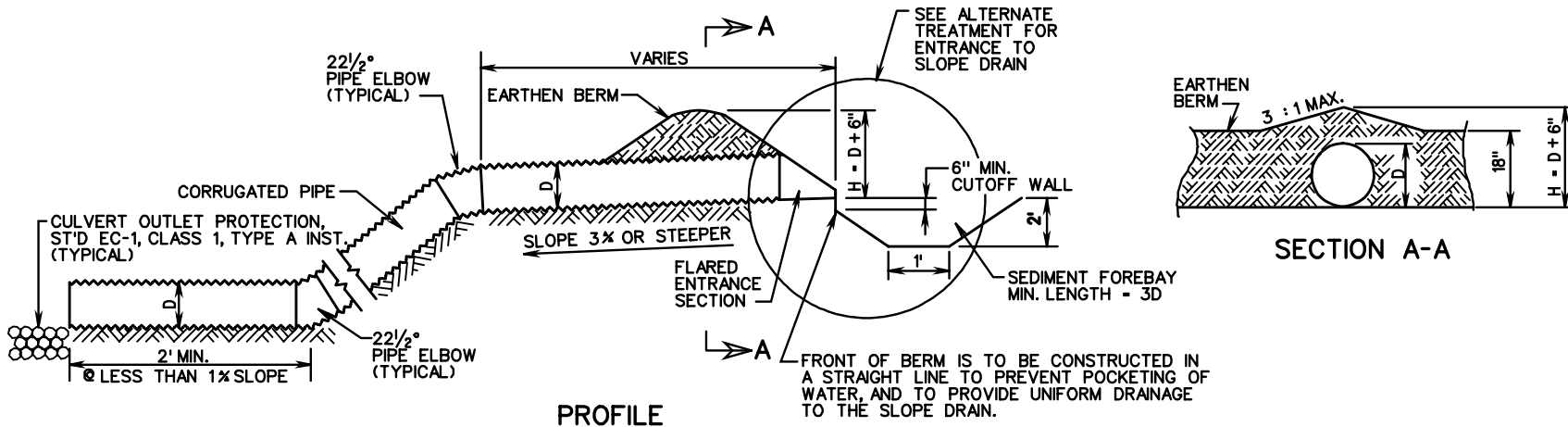

EARTHEN BERM

SIZE OF SLOPE DRAIN	
MAXIMUM DRAINAGE AREA (ACRES)	MINIMUM PIPE DIAMETER, D (IN.)
0.5	12
1.5	18
2.5	21
3.0	24

NOTES

1. SLOPE DRAIN SHALL BE SECURELY STAKED TO THE SLOPE, AT 10' (OR LESS) INTERVALS.
2. THE SLOPE DRAIN SECTIONS SHALL BE SECURELY FASTENED TOGETHER AND HAVE WATER TIGHT FITTINGS.

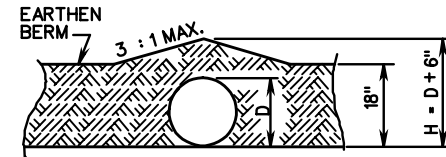

SECTION A-A

ALTERNATE ENTRANCE TREATMENT

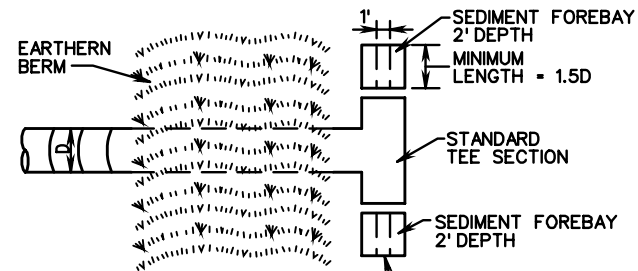

PLAN VIEW

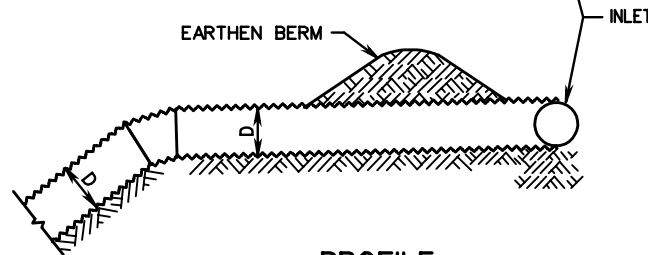

PROFILE



ROAD AND BRIDGE STANDARDS

SHEET 1 OF 1

REVISION DATE

113.14

TEMPORARY BERM & SLOPE DRAIN

VIRGINIA DEPARTMENT OF TRANSPORTATION

SPECIFICATION REFERENCE

107
303

MINIMUM REQUIREMENTS FOR STABILIZED CONSTRUCTION ENTRANCE

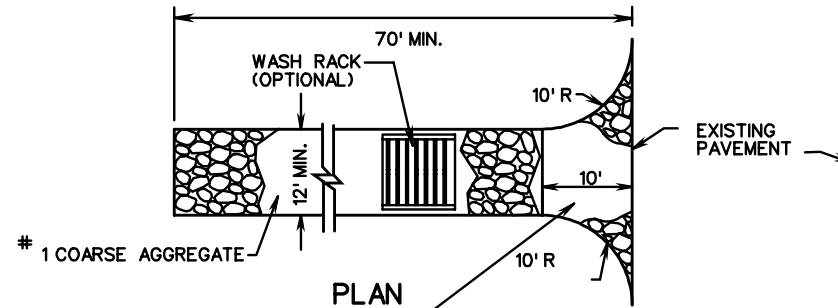

6" MINIMUM DEPTH #1 COARSE AGGREGATE, WITH MINIMUM 10' CLOSEST TO ROADWAY CAPPED WITH 4" MINIMUM DEPTH #68 OR #78 AGGREGATE, AS DIRECTED BY THE ENGINEER.

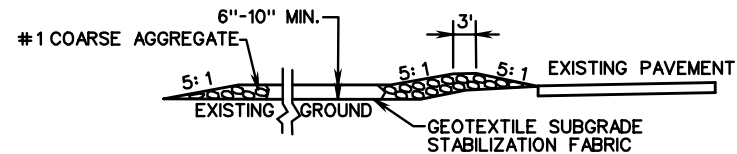

PROFILE

1. SURFACE WATER SHALL BE PIPED UNDER THE CONSTRUCTION ENTRANCE. IF PIPING IS IMPRACTICAL, A MOUNTABLE BERM WITH 5:1 SLOPES WILL BE PERMITTED.
2. THE ENTRANCE SHALL BE MAINTAINED IN A CONDITION WHICH WILL PREVENT TRACKING OR FLOWING OF SEDIMENT ONTO PUBLIC RIGHT OF WAY. THIS MAY REQUIRE PERIODIC TOP DRESSING WITH ADDITIONAL STONE AS CONDITIONS DEMAND AND REPAIR AND/OR CLEANOUT OF ANY MEASURES USED TO TRAP SEDIMENT. ALL SEDIMENT SPILLED, DROPPED, WASHED OR TRACKED ONTO PUBLIC RIGHT OF WAY SHALL BE REMOVED IMMEDIATELY.
3. WHEELS SHALL BE CLEANED TO REMOVE SEDIMENT PRIOR TO ENTRANCE ONTO PUBLIC RIGHT OF WAY. WHEN WASHING IS REQUIRED, IT SHALL BE DONE ON AN AREA STABILIZED WITH STONE AND WHICH DRAINS INTO AN APPROVED SEDIMENT TRAPPING DEVICE.
4. PERIODIC INSPECTION AND NEEDED MAINTENANCE SHALL BE PROVIDED AFTER HEAVY USE AND EACH RAIN.

SPECIFICATION REFERENCE

107
303

STABILIZED CONSTRUCTION ENTRANCE

VIRGINIA DEPARTMENT OF TRANSPORTATION

VDOT

ROAD AND BRIDGE STANDARDS

REVISION DATE

SHEET 1 OF 1

113.15

TYPICAL SECTION
TEMPORARY DIVERSION CHANNEL
AND ACCEPTABLE LININGS

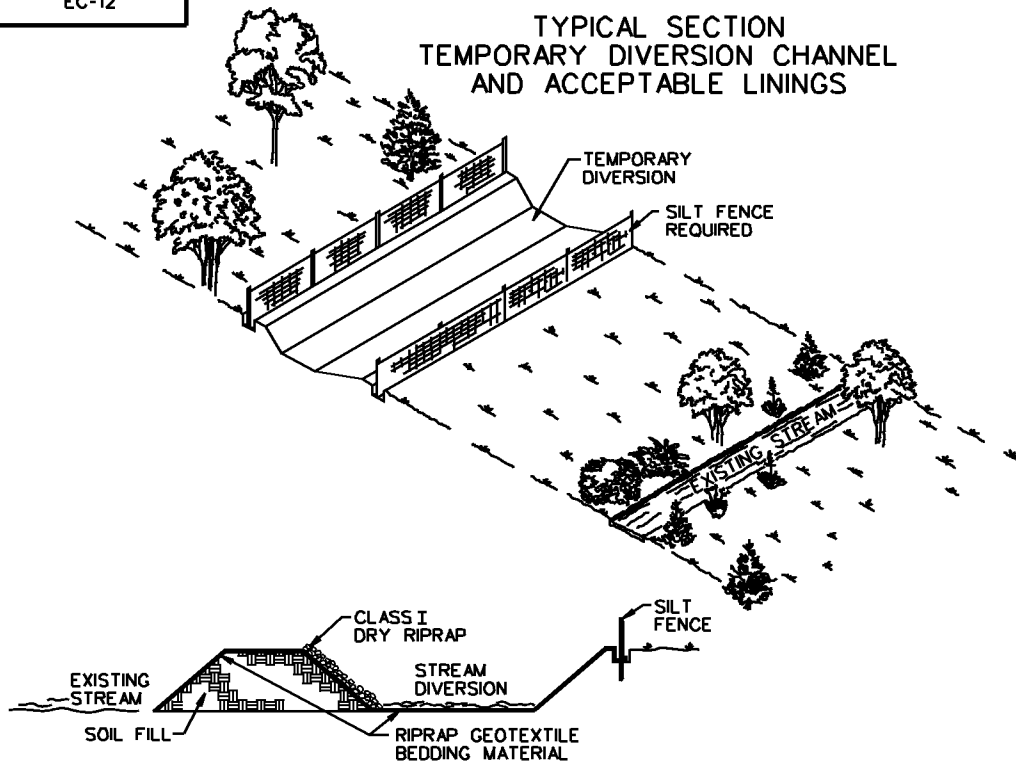

DAM DETAIL

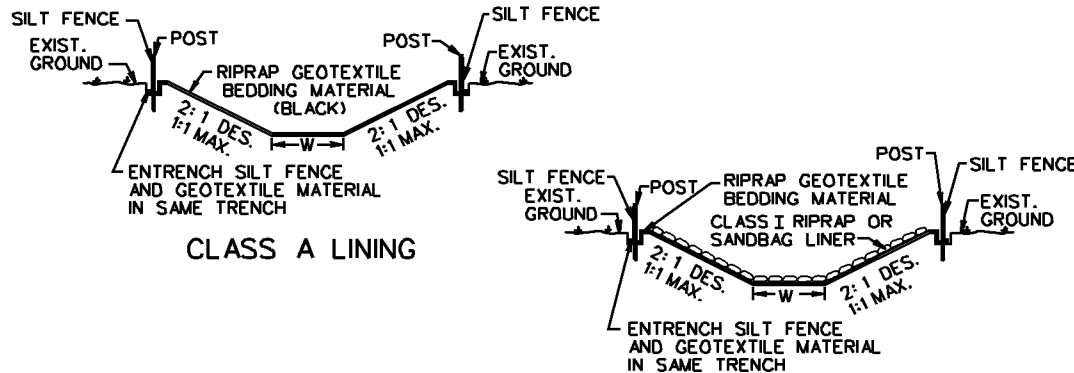

CLASS A LINING

CLASS B LINING

BOTTOM WIDTH OF TEMPORARY DIVERSION CHANNEL SHALL APPROXIMATE THE BOTTOM WIDTH OF THE NATURAL STREAM CHANNEL.

STREAM DIVERSION
GENERAL NOTES

SLOPES

MAXIMUM STEEPNESS OF SIDE SLOPES SHALL BE 1:1. DEPTH AND GRADE MAY BE VARIABLE, DEPENDENT ON SITE CONDITIONS, BUT SHALL BE SUFFICIENT TO ENSURE CONTINUOUS FLOW OF WATER IN THE DIVERSION.

EXCAVATION

NO EXCAVATED MATERIAL SHALL BE STORED OR STOCKPILED NEXT TO THE DIVERSION OR IN SUCH A MANNER THAT SILTATION OF THE STREAM COULD OCCUR.

PIPE CULVERTS

PIPE CULVERT(S) MAY BE USED TO DIVERT A STREAM PROVIDED THEY ARE PROPERLY SIZED TO SAFELY CARRY THE FLOW OF A TWO YEAR STORM EVENT. UNDERSIZED PIPES SHALL BE USED FOR NO LONGER THAN 72 HOURS PROVIDED LESS THAN 50% THREAT OF RAIN CAN BE REASONABLY EXPECTED WITHIN THAT TIME PERIOD AND THEY ARE APPROVED BY THE ENGINEER.

WHEN THE CONTRACTOR USES PIPE CULVERTS IN LIEU OF THE DIVERSION CHANNEL OR A PORTION OF THE CHANNEL, PAYMENT WILL BE MADE BASED ON THE PRICE BID FOR THE QUANTITIES SHOWN ON THE PLANS FOR TEMPORARY DIVERSION CHANNEL EXCAVATION AND TEMPORARY DIVERSION CHANNEL LINING CLASS SPECIFIED.

LINING

THE CONTRACTOR SHALL HAVE THE OPTION OF USING A HIGHER CLASS OF LINING THAN THAT SPECIFIED ON THE PLANS. NO ADDITIONAL COMPENSATION WILL BE ALLOWED FOR USING THE HIGHER CLASS.

STREAM DIVERSION LINERS SHALL BE SECURED AT THE UPSTREAM AND DOWNSTREAM SIDES WITH NON-ERODIBLE WEIGHTS SUCH AS EROSION CONTROL STONE. THESE WEIGHTS SHALL ALLOW NORMAL FLOW OF THE STREAM. SOIL SHALL NOT BE MIXED IN WITH STREAM DIVERSION WEIGHTS. WEIGHTS MAY ALSO BE NEEDED ALONG THE STREAM DIVERSION'S LENGTH.

STREAM DIVERSION LINERS SHALL BE ENTRENCHED AT THE TOP OF THE DIVERSION SLOPES (SLOPE BREAKS) WITH A LINE OF SILT FENCE.

PROTECTIVE COVERING (EC-2) STAPLES OR NON-ERODIBLE WEIGHTS SHALL BE USED AS NECESSARY TO ANCHOR STREAM DIVERSION LINERS TO THE SIDE SLOPES OF THE DIVERSION. WOODEN STAKES SHALL NOT BE USED ON THE DIVERSION'S BOTTOM OR SIDE SLOPES.

STREAM DIVERSION LINERS SHALL BE OVERLAPPED WHEN A SINGLE OR CONTINUOUS LINER IS NOT AVAILABLE OR IS IMPRACTICAL. OVERLAPS SHALL BE PLACED SUCH THAT CONTINUOUS FLOW OF THE STREAM IS MAINTAINED. AN UPSTREAM SECTION SHALL OVERLAP A DOWNSTREAM SECTION BY A MINIMUM OF 18". OVERLAPS ALONG THE CROSS SECTION SHALL BE MADE SUCH THAT A LINER IS PLACED IN THE STREAM DIVERSION BOTTOM FIRST AND ADDITIONAL PIECES OF LINER ON THE SLOPES OVERLAP THE BOTTOM PIECE BY A MINIMUM OF 18".

GENERAL

THE DOWNSTREAM PLUG SHALL BE REMOVED PRIOR TO THE UPSTREAM PLUG WHEN A STREAM DIVERSION IS USED FOR THE TRANSPORT OF WATER.

NON-ERODIBLE MATERIALS, INCLUDING BUT NOT LIMITED TO, EROSION CONTROL STONE, CONCRETE BARRIERS, SANDBAGS, PLYWOOD, OR SHEET PILING SHALL BE USED BOTH TO DIVERT THE STREAMS AWAY FROM THEIR ORIGINAL CHANNELS AND TO PREVENT OR REDUCE WATER BACKUP INTO A CONSTRUCTION AREA.

STREAMS MAY BE DIVERTED THROUGH AN EXISTING OR INCOMPLETE STRUCTURE PROVIDED THEY WILL NOT RE-ENTER A DISTURBED AREA, COME INTO CONTACT WITH WET CONCRETE, AND/OR BECOME PARTIALLY OR WHOLLY IMPOUNDED, SILTED, OR OTHERWISE CONTAMINATED.

STREAMS MAY BE REDIVERTED UPON COMPLETION OF THE DRAINAGE STRUCTURE(S) FOR WHICH THE DIVERSION WAS BUILT. PRIOR TO REDIVERSION, ANY MATERIALS USED TO PREVENT WATER BACKUP INTO THE DOWNSTREAM END OF THE DRAINAGE STRUCTURE(S) SHALL BE REMOVED. THIS MATERIAL SHALL NOT BE PLACED IN THE DOWNSTREAM END OF THE DIVERSION UNTIL AFTER WATER HAS BEEN REDIVERTED TO THE DRAINAGE STRUCTURE(S). A STREAM SHALL BE REDIVERTED BY REMOVING ALL OF THE MATERIALS DAMMING THE UPSTREAM END OF THE DRAINAGE STRUCTURE(S) BEFORE PLACING IT IN THE UPSTREAM END OF THE STREAM DIVERSION. THE DIVERSION SHALL BE SEALED OFF AT THE DOWNSTREAM END AND THEN BACKFILLED.

ONCE STARTED, ANY WORK TO RELOCATE A STREAM (PLUGS) SHALL NOT BE DISCONTINUED UNTIL IT IS COMPLETED.

ANY DEVIATIONS TO THE ABOVE NOTED STREAM DIVERSION DESIGN, INSTALLATION, OR MAINTAINANCE SHALL BE APPROVED BY THE ENGINEER.



ROAD AND BRIDGE STANDARDS

SHEET 1 OF 1

REVISION DATE

113.16

4/09

TEMPORARY DIVERSION CHANNEL

VIRGINIA DEPARTMENT OF TRANSPORTATION

SPECIFICATION
REFERENCE

302

303

414

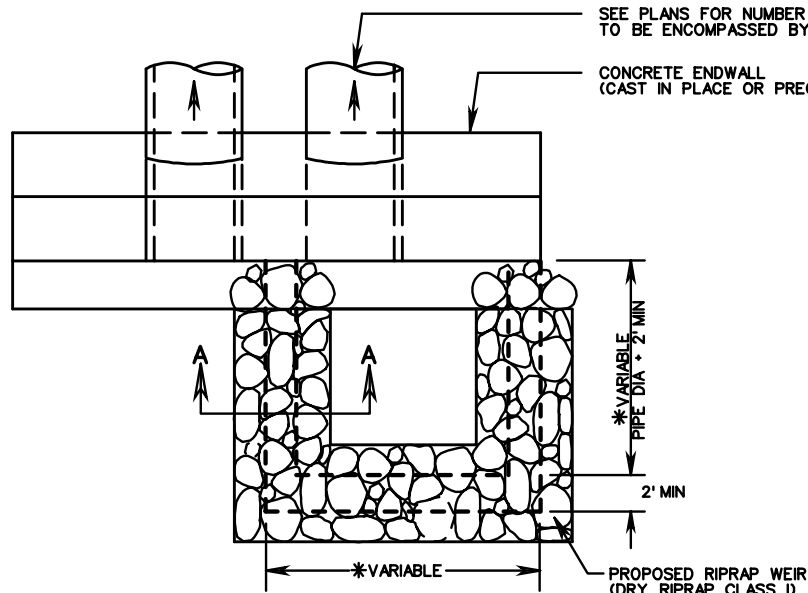

PLAN VIEW
(ENDWALL WITHOUT WINGS)

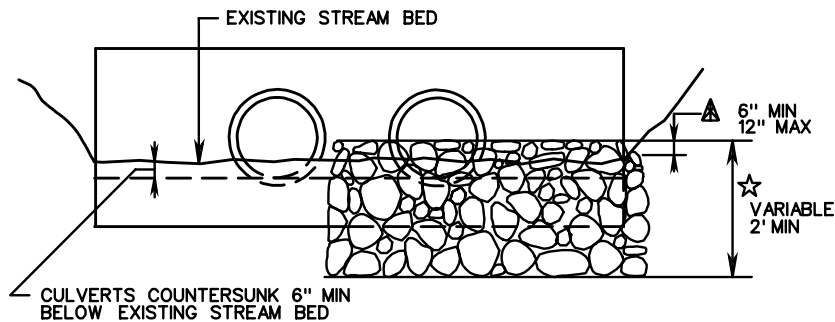

END VIEW

LEGEND

- Ⓐ 6' MINIMUM OR 1/2 P.
- * DIMENSION VARIES ACCORDING TO PIPE SIZE, SKEW AND ENDWALL DIMENSIONS
- ☆ DEPTH OF FOUNDATION TO BE VARIABLE ACCORDING TO SITE CONSTRAINTS OR AS DIRECTED BY THE ENGINEER
- ▲ THE PROPOSED HEIGHT OF THE RIPRAP WEIR, FROM THE EXISTING STREAM BED TO THE TOP OF WEIR, IS TO BE SPECIFIED ON THE ROADWAY PLANS. "X" DIMENSION (HEIGHT OF WEIR ABOVE STREAM BED) CAN BE A MINIMUM OF 6" OR ANY VARIABLE DIMENSION TO A MAXIMUM OF 12".

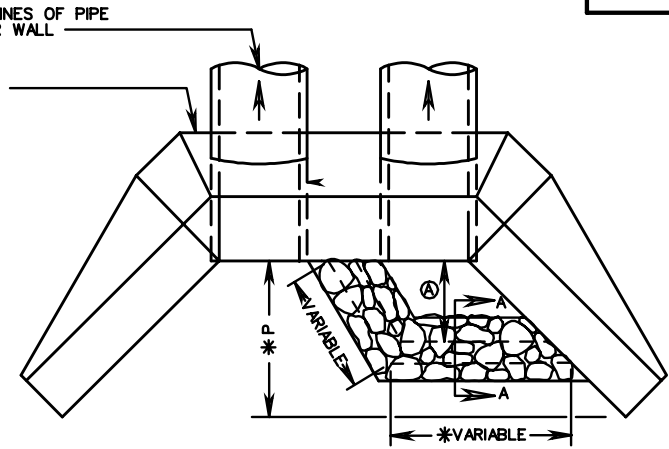

PLAN VIEW
(ENDWALL WITH WINGS)

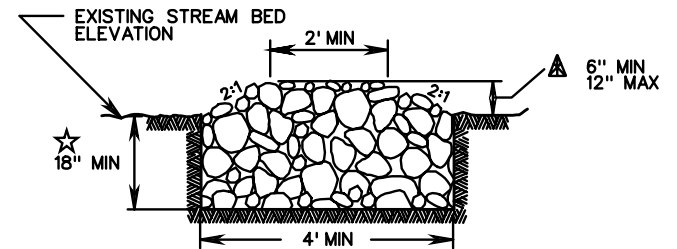

TYPICAL SECTION A-A

NOTES:

1. THE TOP WIDTH OF THE WEIR IS VARIABLE AND IS TO BE ADJUSTED AS NEEDED TO DIRECT THE LOW FLOW TO THE BARREL(S) DESIGNATED ON THE PLANS.
2. FOR SKEWED ENDWALLS, RIPRAP WEIR SIDES ARE TO BE CONSTRUCTED PARALLEL WITH PIPE SKEW.
3. REFER TO APPLICABLE ENDWALL STANDARD DRAWING FOR DIMENSIONS NOT SHOWN HEREIN
4. BASIS OF PAYMENT: TO BE PAID FOR AS SQ.YDS. OR TONS OF DRY RIPRAP CLASS I

SPECIFICATION
REFERENCE

107
303

RIPRAP WEIRS

LOW FLOW DIVERSION FOR MULTIPLE LINE CULVERT INSTALLATIONS

VIRGINIA DEPARTMENT OF TRANSPORTATION

VDOT

ROAD AND BRIDGE STANDARDS

REVISION DATE

SHEET 1 OF 1

113.17

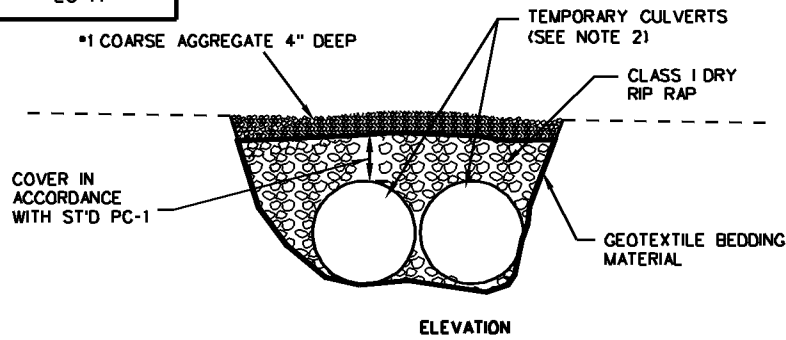

ELEVATION

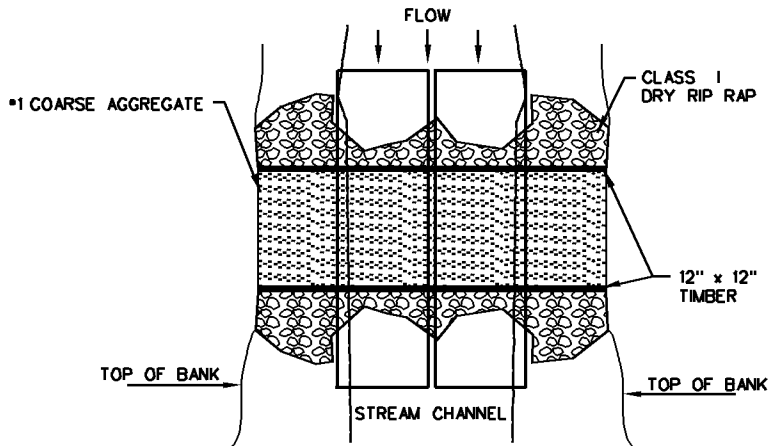

PLAN VIEW

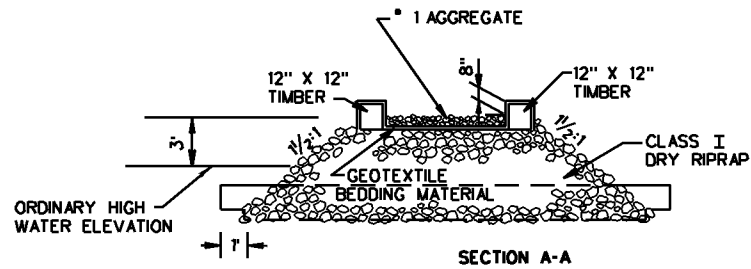
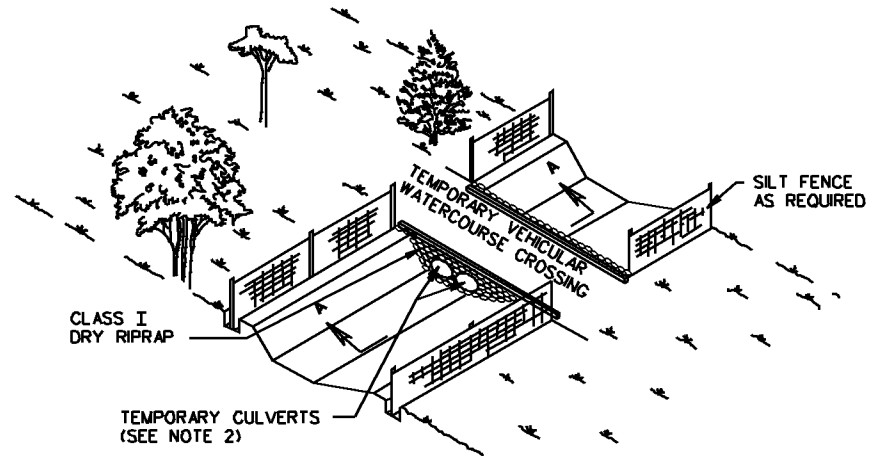

NOTE:

1. THE CULVERT(S) SHALL BE SIZED TO CONVEY THE FLOW OF A TWO YEAR STORM EVENT. THE ELEVATION OF THE TWO YEAR EVENT SHALL BE AT OR BELOW THE LOWEST SURFACE ELEVATION OF THE CROSSING. THE REQUIRED HYDRAULIC OPENINGS SHOULD BE DETERMINED USING THE APPROPRIATE HYDROLOGIC/HYDRAULIC DESIGN TECHNIQUES. A TEMPORARY VEHICULAR WATERCOURSE CROSSING SHOULD ONLY BE UTILIZED WHERE THE DRAINAGE AREA IS NO GREATER THAN 1 SQUARE MILE. THE DEPTH OF STONE COVER OVER THE CULVERT(S) SHALL BE IN ACCORDANCE WITH STANDARD PC-1.

2. AN ALTERNATIVE TEMPORARY VEHICULAR WATERCOURSE CROSSING DESIGN MAY BE USED PROVIDED IT IS SUBMITTED TO THE ENGINEER FOR REVIEW AND APPROVAL IN ACCORDANCE WITH ROAD AND BRIDGE SPECIFICATIONS 105.10 AND 107.02.



ROAD AND BRIDGE STANDARDS

TEMPORARY VEHICULAR WATERCOURSE CROSSING

SPECIFICATION REFERENCE

SHEET 1 OF 1

REVISION DATE

113.18

4/09

VIRGINIA DEPARTMENT OF TRANSPORTATION

302
303
414

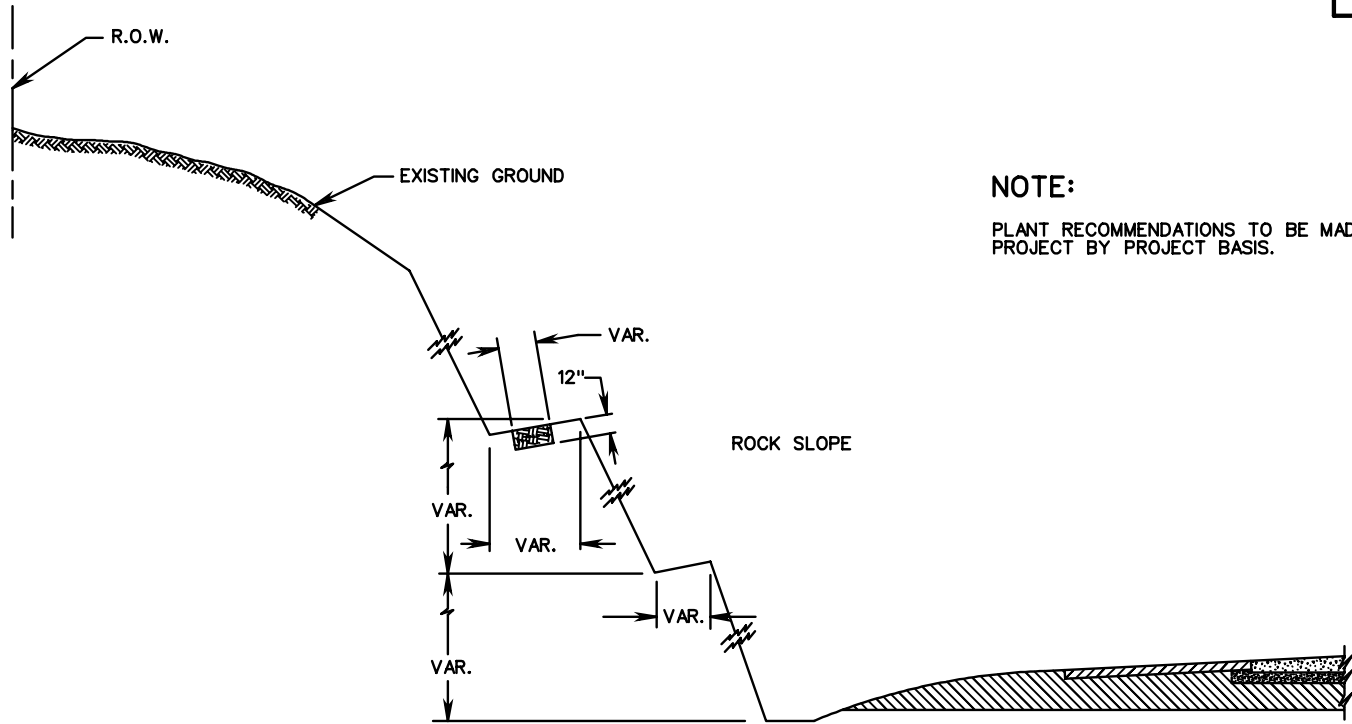

NOTE:

PLANT RECOMMENDATIONS TO BE MADE ON A PROJECT BY PROJECT BASIS.

SECTION A-A

THIS SECTION IS TO BE USED AS A GUIDE ONLY. EACH ROCK CUT SHOULD RECEIVE INDIVIDUAL INVESTIGATION.

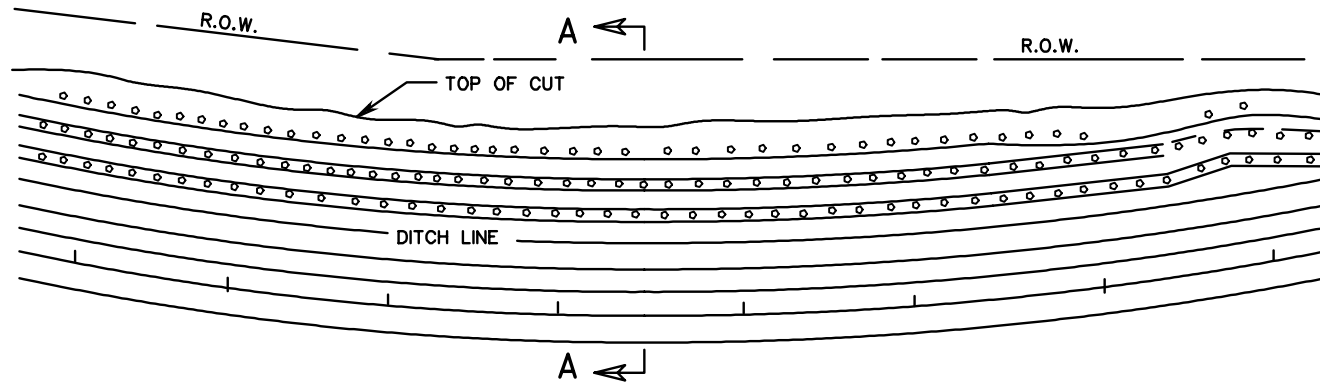

SPECIFICATION REFERENCE

NONE

**BENCH PLANTING ON ROCK CUT SECTION
TYPICAL SECTION**

VIRGINIA DEPARTMENT OF TRANSPORTATION

VDOT

ROAD AND BRIDGE STANDARDS

REVISION DATE

SHEET 1 OF 1

1201.01

CUT SLOPES STEEPER THAN 2:1 SHALL BE GROOVED IN ACCORDANCE WITH DETAILS SHOWN.

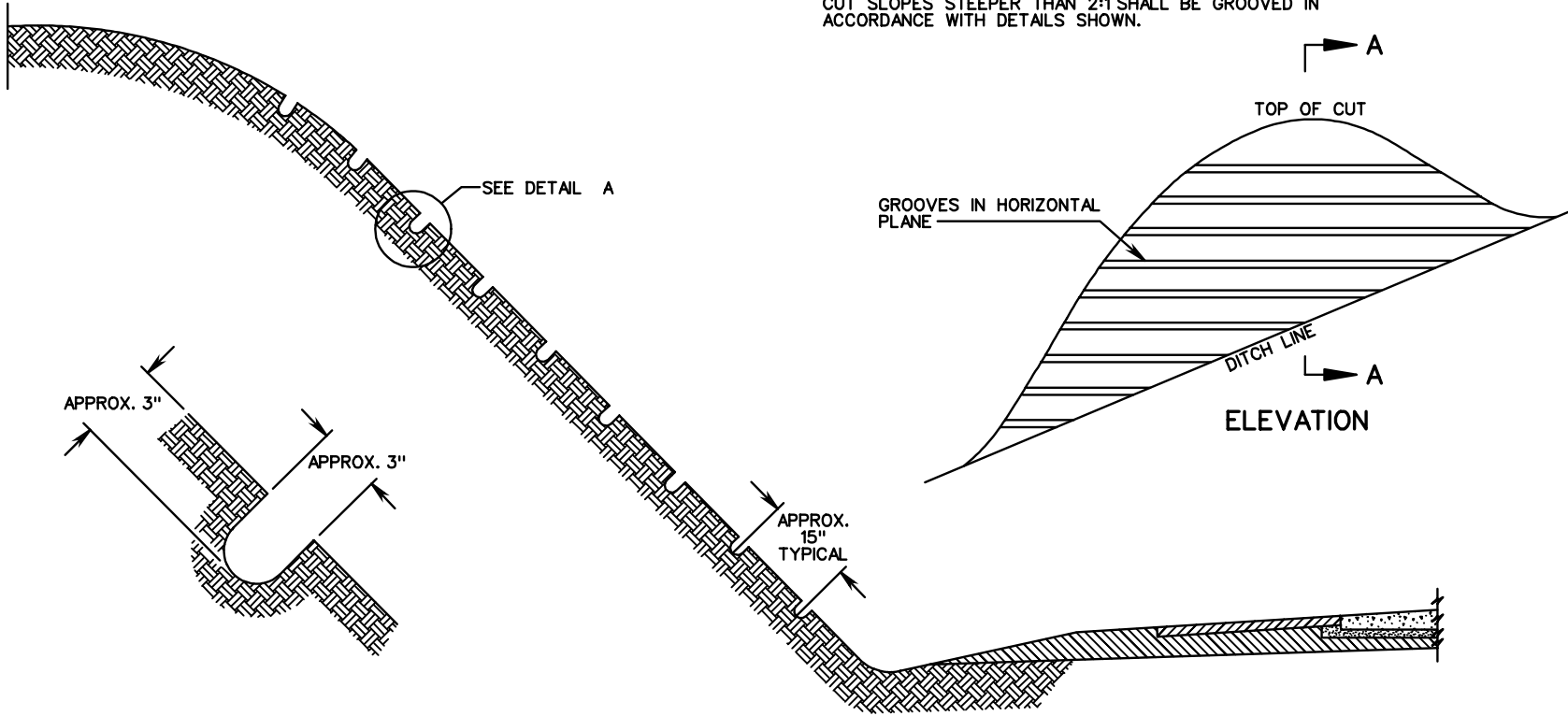

DETAIL A

SECTION A-A



ROAD AND BRIDGE STANDARDS

HORIZONTAL GROOVING CUT SLOPES TYPICAL METHOD

SPECIFICATION
REFERENCE

SHEET 1 OF 1

REVISION DATE

1201.02

VIRGINIA DEPARTMENT OF TRANSPORTATION

303

OUTSIDE ROAD DITCHES

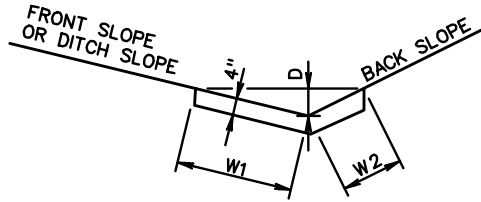

TYPE	D	FRONT SLOPE	BACK SLOPE	W1	W2	K	SQ. YDS. SURFACE AREA/LIN. FT.
A1	6"	6:1	4:1	3'-0"	2'-1"	48	0.565
A1	8"	6:1	4:1	4'-1"	2'-9"	104	0.759
A2	6"	6:1	3:1	3'-0"	1'-7"	42	0.509
A2	8"	6:1	3:1	4'-1"	2'-1"	92	0.685
A3	6"	6:1	2:1	3'-0"	1'-2"	38	0.463
A3	8"	6:1	2:1	4'-1"	1'-6"	82	0.620
B1	6"	4:1	4:1	2'-1"	2'-1"	38	0.463
B1	8"	4:1	4:1	2'-9"	2'-9"	82	0.611
B2	8"	4:1	3:1	2'-9"	2'-1"	72	0.537
B2	10"	4:1	3:1	3'-5"	2'-8"	130	0.676
B3	8"	4:1	2:1	2'-9"	1'-6"	60	0.472
B3	10"	4:1	2:1	3'-5"	1'-10"	111	0.583
B4	8"	4:1	1/2:1	2'-9"	1'-2"	55	0.435
B4	10"	4:1	1/2:1	3'-5"	1'-6"	101	0.546
C1	8"	3:1	2:1	2'-1"	1'-6"	50	0.398
C1	10"	3:1	2:1	2'-8"	1'-10"	92	0.500
C2	10"	3:1	1/2:1	2'-8"	1'-6"	80	0.463
C3	10"	3:1	1:1	2'-8"	1'-2"	70	0.426

MEDIAN DITCH

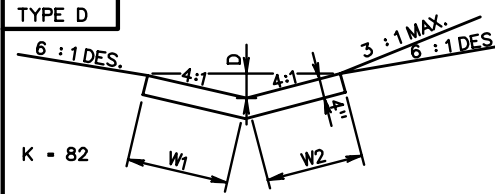

D - DEPTH	W1	W2	SQ. YDS. SURFACE AREA PER LIN. FT.
8"	2'-9"	2'-9"	0.611

DITCH AT TOE OF FILL OR TOP OF CUT

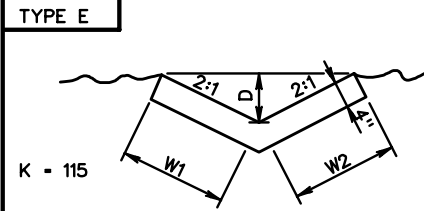

D - DEPTH	W1	W2	SQ. YDS. SURFACE AREA PER LIN. FT.
12"	2'-3"	2'-3"	0.500

CURTAIN WALL DETAIL

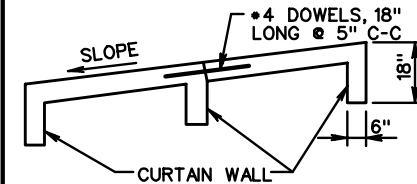

CURTAIN WALL TO BE LOCATED AT BEGINNING AN END OF ALL CHANNELS AND ON THE LOWER END OF EACH EXPANSION JOINT.

PLAN FOR TRANSITION OF PAVED MEDIAN DITCH TO MEDIAN DROP INLET GUTTER

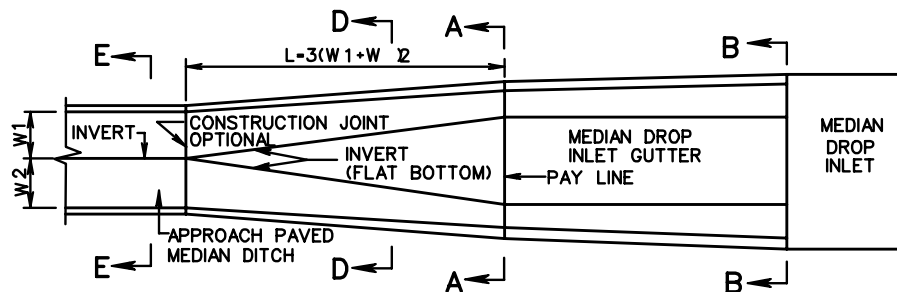

NOTES:
 FOR SECTION A-A AND B-B SEE STANDARDS DI-7, 7A AND 7B.
 TRADITIONAL PORTION OF PAVED DITCH TO BE PAID FOR AT THE SAME PRICE BID PER SQ. YARD FOR APPROACH PAVED MEDIAN DITCH.
 STANDARD PG-2A DITCHES TO BE CLASS A3 CONCRETE.

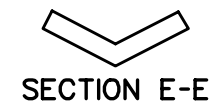
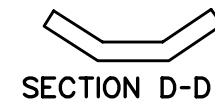

ALTERNATE METHOD OF FORMING DITCHES

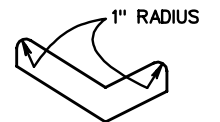

NOTE:
 ALL DITCHES MAY BE CONSTRUCTED WITH VERTICAL SIDES AT THE OPTION OF THE CONTRACTOR.

SPECIFICATION REFERENCE

502

STANDARD PAVED DITCHES

VIRGINIA DEPARTMENT OF TRANSPORTATION

VDOT

ROAD AND BRIDGE STANDARDS

REVISION DATE

SHEET 1 OF 1

109.01

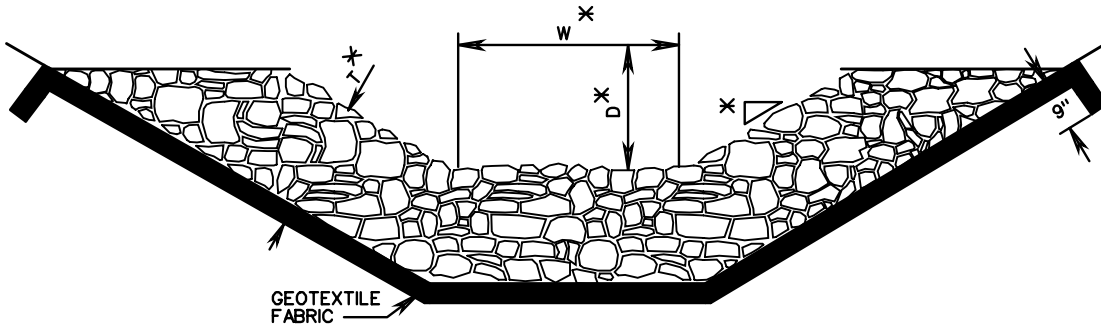

TYPE I
RIPRAP DITCH PROTECTION

MINIMUM THICKNESS "T"

RIP RAP CLASS	MINIMUM "T"
CLASS AI	20"
CLASS I	26"
CLASS II	38"
CLASS III	53"

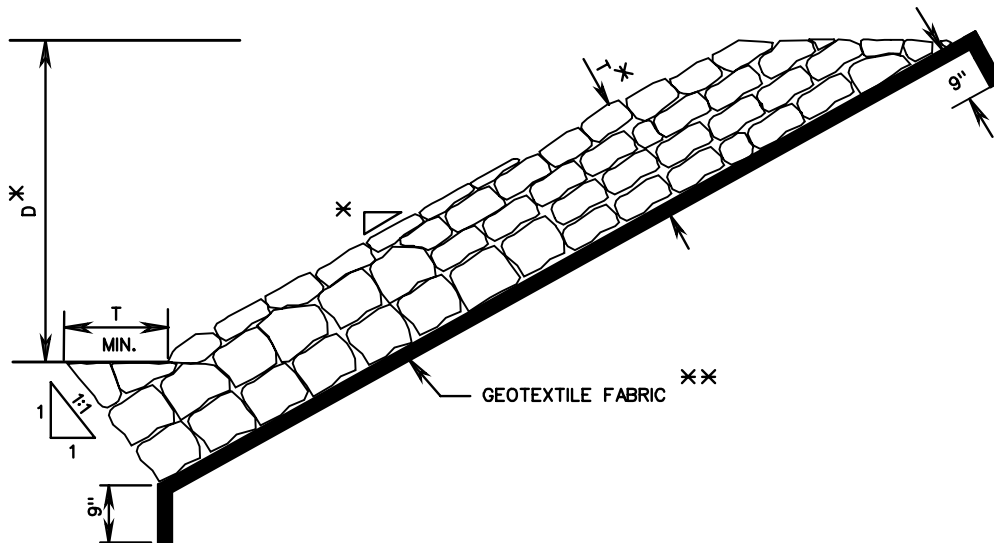

TYPE II
RIPRAP SLOPE PROTECTION

NOTES:

- ×× RIP RAP BEDDING MATERIAL
- GEOTEXTILE FABRIC TO BE PROVIDED UNDER ALL RIPRAP INSTALLATIONS CLASS AI, CLASS I AND CLASS II UNLESS OTHERWISE NOTED ON THE PLANS OR DIRECTED BY THE ENGINEER.
- RIPRAP INSTALLATIONS OF CLASS III SHALL HAVE AN INTERMEDIATE AGGREGATE BEDDING LAYER(S) AS SPECIFIED ON THE PLANS BASED ON GEOTECHNICAL RECOMMENDATIONS.
- × SEE TYPICAL SECTION SHOWN ON PLANS FOR SIDE SLOPE, BOTTOM WIDTH AND DEPTH OF CHANNEL AND RIPRAP THICKNESS.



ROAD AND BRIDGE STANDARDS

STANDARD RIP RAP DITCH & SLOPE PROTECTION
PG-3

SPECIFICATION
REFERENCE

SHEET 1 OF 1

REVISION DATE

109.02

VIRGINIA DEPARTMENT OF TRANSPORTATION

245
414

 INDICATES CHANNEL WHERE WIRE MESH REINFORCEMENT IS NOT REQUIRED.

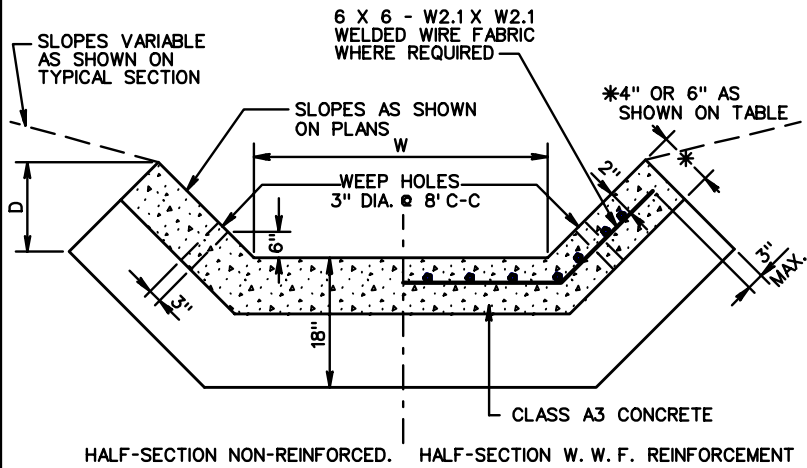

SECTION A-A

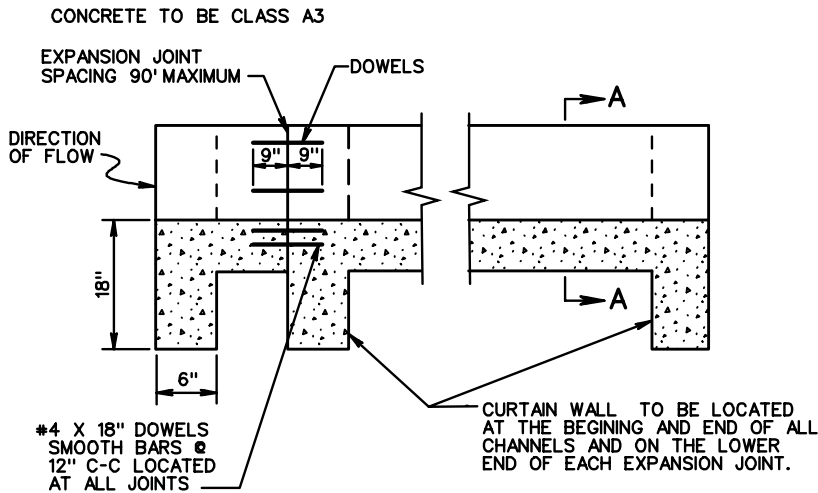

ELEVATION

SQUARE YARDS PER LIN. FT. OF PAVED CHANNEL

CONC. THICKNESS	D	W									
		1'	2'	3'	4'	5'	6'	7'	8'	9'	10'
1:1 SIDE SLOPES											
4"	1'	0.425	0.536	0.648	0.759	0.870	0.981	1.092	1.203	1.314	1.425
	2'	0.740	0.851	0.962	1.073	1.184	1.295	1.406	1.517	1.629	1.740
	3'	1.054	1.165	1.276	1.387	1.498	1.609	1.721	1.832	1.943	2.054
	4'	1.368	1.479	1.590	1.702	1.813	1.924	2.035	2.146	2.257	2.368
6"	5'	1.682	1.794	1.905	2.016	2.127	2.238	2.349	2.460	2.571	2.682
	6'	1.997	2.108	2.219	2.330	2.441	2.552	2.663	2.774	2.886	2.997
	7'	2.311	2.422	2.533	2.644	2.755	2.866	2.977	3.089	3.200	3.311
	8'	2.625	2.736	2.848	2.959	3.070	3.181	3.292	3.403	3.514	3.625
	9'	2.940	3.051	3.162	3.273	3.384	3.495	3.606	3.717	3.828	3.939
	10'	3.254	3.365	3.476	3.587	3.698	3.809	3.920	4.032	4.143	4.254
1.5:1 SIDE SLOPES											
4"	1'	0.512	0.623	0.734	0.845	0.956	1.067	1.178	1.290	1.401	1.512
	2'	0.912	1.023	1.135	1.246	1.357	1.468	1.579	1.690	1.801	1.912
	3'	1.313	1.424	1.535	1.646	1.757	1.869	1.980	2.091	2.202	2.313
	4'	1.714	1.825	1.936	2.047	2.158	2.269	2.380	2.491	2.602	2.714
6"	5'	2.114	2.225	2.336	2.448	2.559	2.670	2.781	2.892	3.003	3.114
	6'	2.515	2.626	2.737	2.848	2.959	3.070	3.181	3.293	3.404	3.515
	7'	2.915	3.027	3.138	3.249	3.360	3.471	3.582	3.693	3.804	3.915
	8'	3.316	3.427	3.538	3.649	3.760	3.872	3.983	4.094	4.205	4.316
	9'	3.717	3.828	3.939	4.050	4.161	4.272	4.383	4.494	4.606	4.717
	10'	4.117	4.228	4.340	4.451	4.562	4.673	4.784	4.895	5.006	5.117
2:1 SIDE SLOPES											
4"	1'	0.608	0.719	0.830	0.941	1.052	1.164	1.275	1.386	1.497	1.608
	2'	1.105	1.216	1.327	1.438	1.549	1.660	1.772	1.883	1.994	2.105
	3'	1.602	1.713	1.824	1.935	2.046	2.157	2.268	2.380	2.491	2.602
	4'	2.099	2.210	2.321	2.432	2.543	2.654	2.765	2.876	2.988	3.099
6"	5'	2.596	2.707	2.818	2.929	3.040	3.151	3.262	3.373	3.485	3.596
	6'	3.093	3.204	3.315	3.426	3.537	3.648	3.759	3.870	3.981	4.093
	7'	3.589	3.701	3.812	3.923	4.034	4.145	4.256	4.367	4.478	4.589
	8'	4.086	4.197	4.309	4.420	4.531	4.642	4.753	4.864	4.975	5.086
	9'	4.583	4.694	4.805	4.917	5.028	5.139	5.250	5.361	5.472	5.583
	10'	5.080	5.191	5.302	5.413	5.525	5.636	5.747	5.858	5.969	6.080

NOTES:

DEPTH (D) AND WIDTH (W) TO BE AS SHOWN ON PLANS.
 WEEP HOLES ARE TO BE PROVIDED ON ALL CHANNELS WHERE W IS EQUAL TO OR GREATER THAN 4' AND D IS EQUAL TO OR GREATER THAN 2'.
 WEEP HOLE WITH 12" X 12" PLASTIC HARDWARE CLOTH, 1/4" MESH OR GALVANIZED STEEL WIRE DIAMETER 0.03 INCH, NUMBER 4 MESH, HARDWARE CLOTH ANCHORED FIRMLY TO THE BOTTOM OF THE CHANNEL.



ROAD AND BRIDGE STANDARDS

SHEET 1 OF 1

REVISION DATE

109.04

STANDARD PAVED DITCHES

VIRGINIA DEPARTMENT OF TRANSPORTATION

SPECIFICATION REFERENCE

502

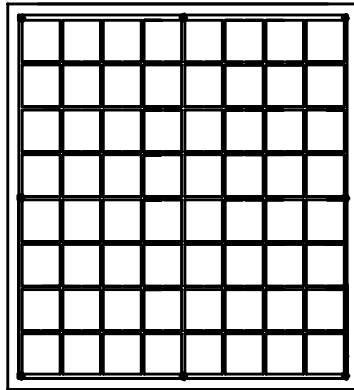

PLAN VIEW

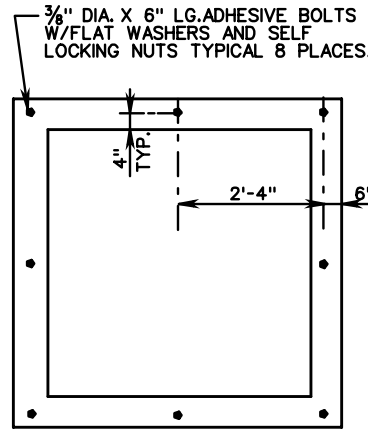

PLAN VIEW
(TRASH RACK NOT SHOWN)

NOTES:

1. COST OF TRASH RACK AND DEBRIS RACK ARE TO BE INCLUDED IN THE BID PRICE FOR THE STORMWATER MANAGEMENT DRAINAGE STRUCTURE.
2. STRUCTURE MAY BE PRECAST OR CAST IN PLACE. SEE SHEET 2 OF 2 FOR DETAILS ON PRECAST STRUCTURE.
3. WEEP HOLES SHALL NOT BE PROVIDED.
4. STEPS ARE TO BE PROVIDED WHEN HEIGHT OF STRUCTURE IS 4'-0" OR GREATER ABOVE INVERT OF OUTLET PIPE. FOR STEP DETAILS SEE STANDARD ST-1.
5. FOR DETAILS ON METAL PLATE, DEBRIS RACK AND TRASH RACK SEE STANDARD SWM-DR.
6. MARK HEIGHT OF STRUCTURE, IN BLACK, WITH 4" HIGH NUMERALS AND 1" WIDE HORIZONTAL STRIPES AT 1' INTERVALS FROM INVERT OF WATER QUALITY ORIFICE (ALL VISIBLE SIDES).
7. THE PERMANENT STORMWATER MANAGEMENT DRAINAGE STRUCTURE, STANDARD SWM-1 MAY BE MODIFIED WHERE THE STORMWATER MANAGEMENT BASIN IS TO BE USED AS A TEMPORARY SEDIMENT BASIN DURING PROJECT CONSTRUCTION. SEE STANDARD SWM-DR, SHEET 1 OF 5, FOR TEMPORARY MODIFICATION DETAILS.
8. THE SIZE OF THE WATER QUALITY ORIFICE SHALL BE SPECIFIED ON THE PLANS. ADDITIONAL OPENINGS IN THE STORMWATER MANAGEMENT STRUCTURE TO BE PROVIDED WHEN SPECIFIED ON THE PLANS.

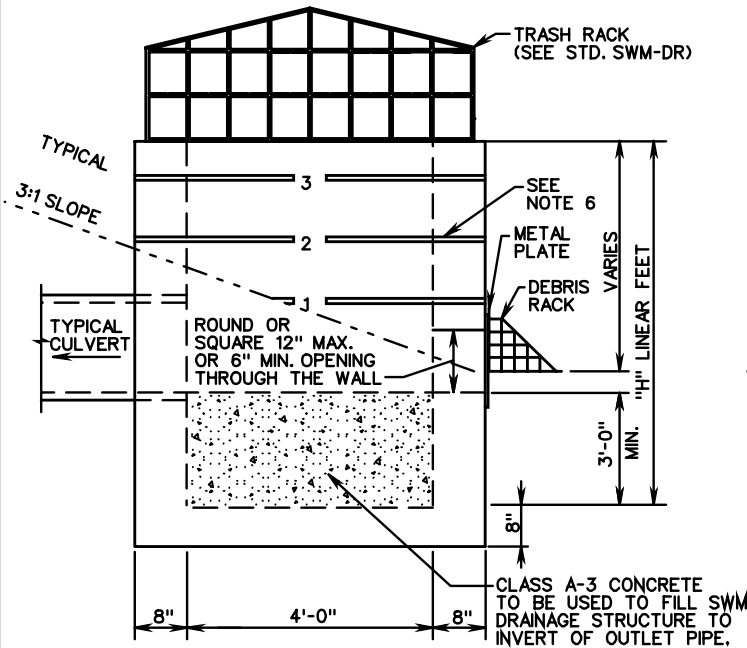

SIDE VIEW

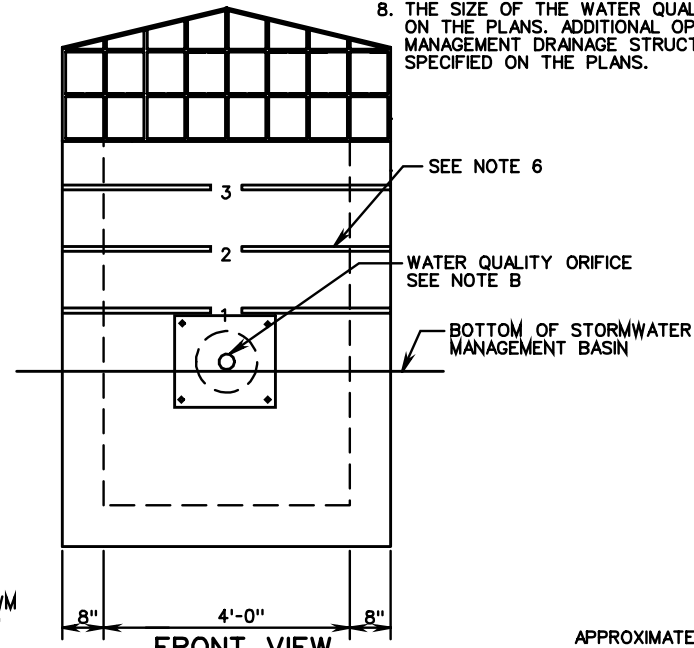

FRONT VIEW
(DEBRIS RACK NOT SHOWN)

APPROXIMATE QUANTITIES
CAST-IN-PLACE CLASS A-3 CONCRETE TO BE USED.
MAXIMUM DEPTH (H) TO BE 12'-8".

PIPE SIZE	12"	15"	18"	24"	30"	36"	42"
MINIMUM DEPTH H	5'-0"	5'-3/4"	5'-6 1/2"	6'-1"	6'-7 1/2"	7'-2"	7'-8 1/2"
CU. YDS. CONCRETE	2.665	2.773	2.878	3.078	3.624	3.437	3.598

INCREMENT PER FOOT OF ADDITIONAL DEPTH "H" = 0.461 CU. YDS.

SPECIFICATION REFERENCE

302

CAST IN PLACE STORMWATER MANAGEMENT DRAINAGE STRUCTURE

VIRGINIA DEPARTMENT OF TRANSPORTATION

VDOT

ROAD AND BRIDGE STANDARDS

REVISION DATE

SHEET 1 OF 3

114.01

NOTES:

1. COST OF TRASH RACK AND DEBRIS RACK ARE TO BE INCLUDED IN THE PRICE BID FOR THE STORMWATER MANAGEMENT DRAINAGE STRUCTURE.
2. STRUCTURE MAY BE PRECAST OR CAST IN PLACE. SEE SHEET 1 OF 2 FOR DETAILS ON CAST IN PLACE STRUCTURE.
3. WEEP HOLES SHALL NOT BE PROVIDED. ANY LIFT HOLES SHALL BE PLUGGED.
4. STEPS ARE TO BE PROVIDED WHEN HEIGHT OF STRUCTURE IS 4'-0" OR GREATER ABOVE INVERT OF OUTLET PIPE. FOR STEP DETAILS SEE STANDARD ST-1.
5. SEE STANDARD SWM-DR FOR DETAILS ON PLATE, DEBRIS RACK AND TRASH RACK.
6. MARK HEIGHT OF STRUCTURE, IN BLACK, WITH 4" HIGH NUMERALS AND 1" WIDE HORIZONTAL STRIPES AT 1' INTERVALS FROM INVERT OF WATER QUALITY ORIFICE (ALL VISIBLE SIDES).
7. THE PERMANENT STORMWATER MANAGEMENT DRAINAGE STRUCTURE, STANDARD SWM-1 MAY BE MODIFIED WHERE THE STORMWATER MANAGEMENT BASIN IS TO BE USED AS A TEMPORARY SEDIMENT BASIN DURING PROJECT CONSTRUCTION. SEE STANDARD SWM-DR, SHEET 1 OF 5 FOR TEMPORARY MODIFICATION DETAILS.
8. THE SIZE OF THE WATER QUALITY ORIFICE SHALL BE SPECIFIED ON THE PLANS. ADDITIONAL OPENINGS IN THE STORMWATER MANAGEMENT DRAINAGE STRUCTURE TO BE PROVIDED WHEN SPECIFIED ON THE PLANS.

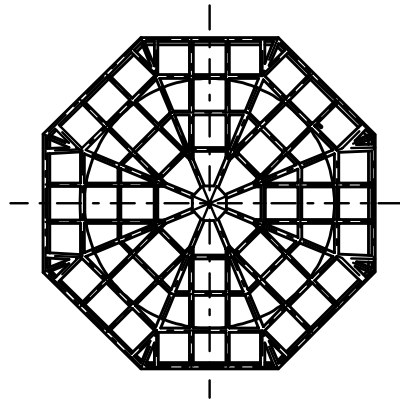

PLAN VIEW

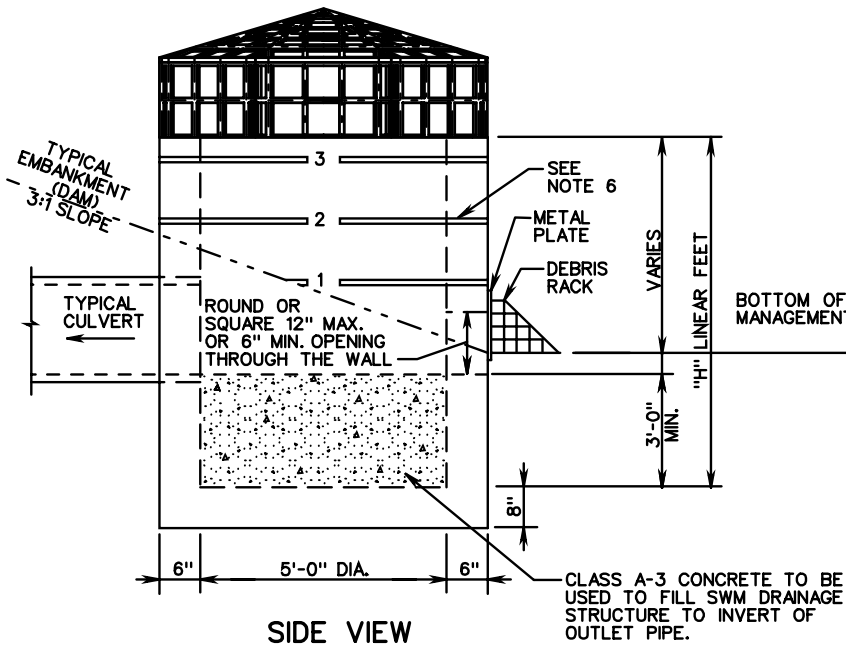

SIDE VIEW

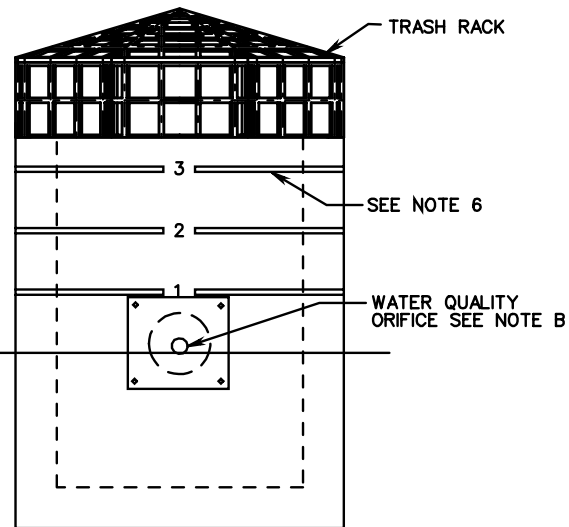

FRONT VIEW
(DEBRIS RACK NOT SHOWN)



ROAD AND BRIDGE STANDARDS

PRECAST STORMWATER MANAGEMENT DRAINAGE STRUCTURE

SPECIFICATION REFERENCE

SHEET 2 OF 3

REVISION DATE

114.02

VIRGINIA DEPARTMENT OF TRANSPORTATION

105
302

NOTE:

GRATE AND COLLAR ARE TO BE GALVANIZED AFTER FABRICATION. COST OF THIS GRATE AND COLLAR ARE TO BE INCLUDED IN THE PRICE BID FOR STORMWATER MANAGEMENT DRAINAGE STRUCTURE.

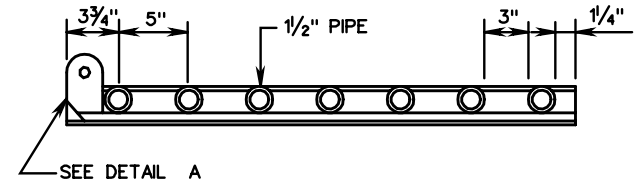
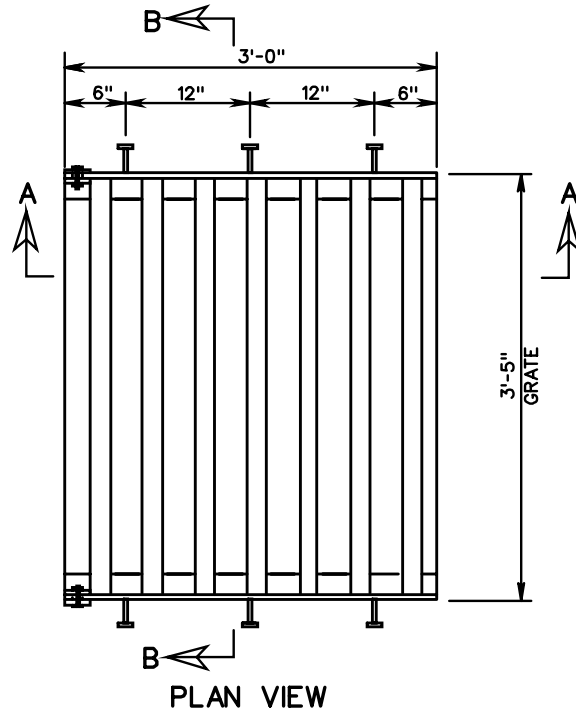

SECTION A-A

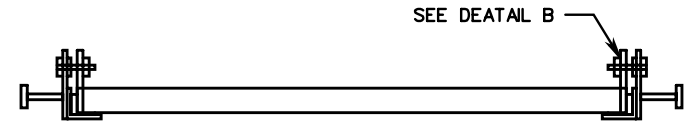

SECTION B-B

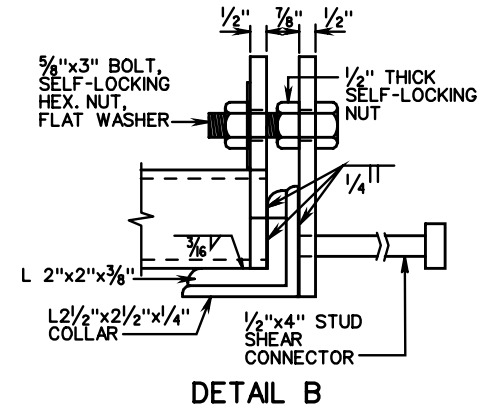
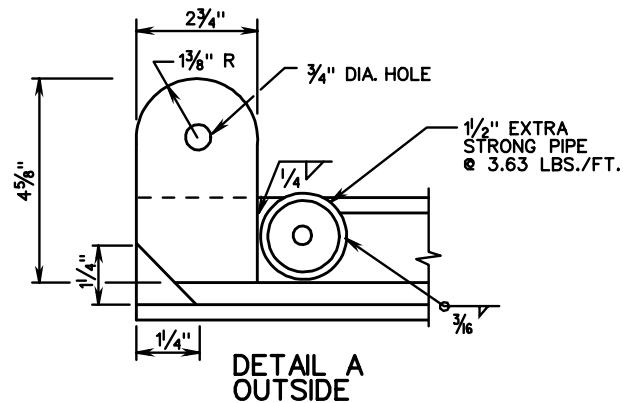
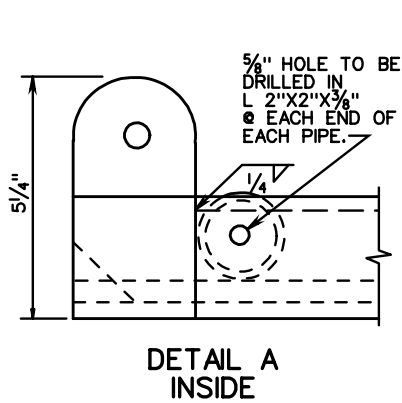

SPECIFICATION REFERENCE

302

STORMWATER MANAGEMENT DRAINAGE STRUCTURE GRATE DETAILS

VIRGINIA DEPARTMENT OF TRANSPORTATION

VDOT

ROAD AND BRIDGE STANDARDS

REVISION DATE

SHEET 3 OF 3

114.03

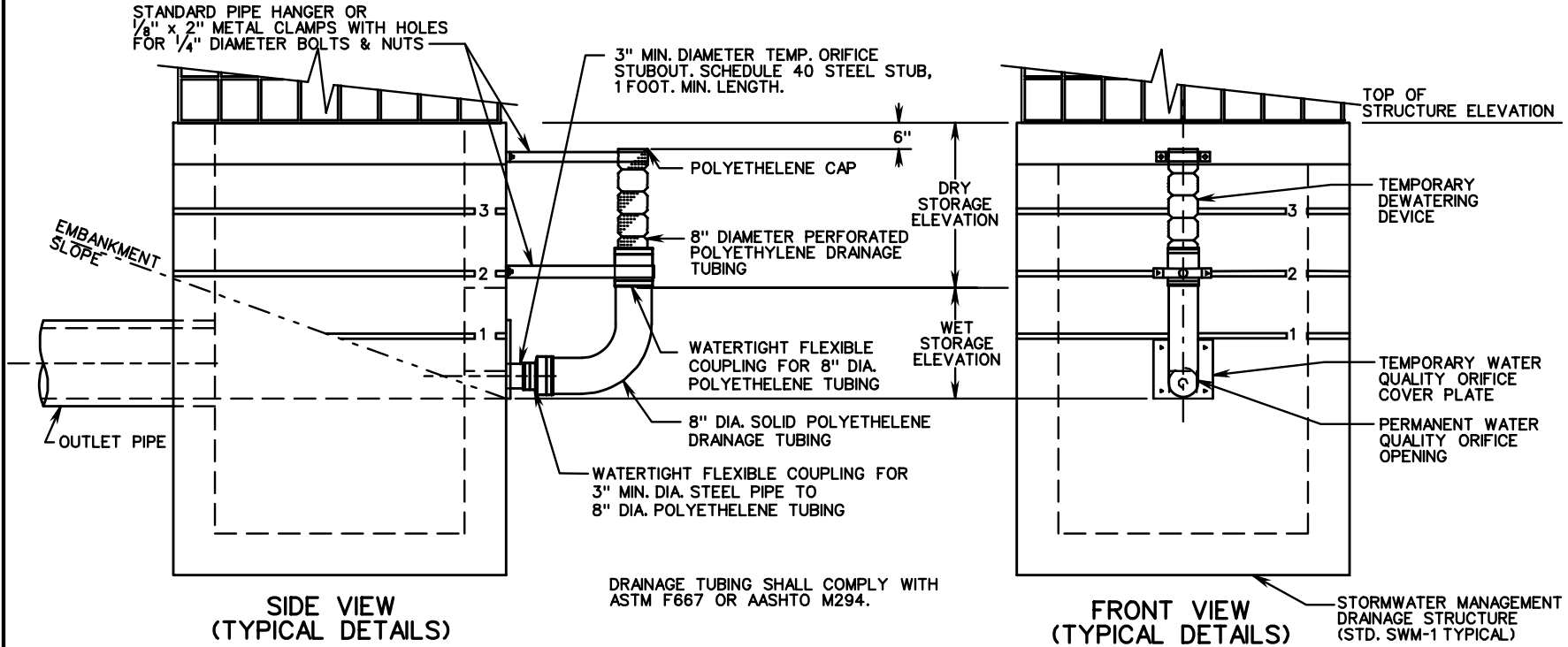

NOTES:

1. THESE DETAILS ARE TO BE USED TO MODIFY THE PERMANENT STORMWATER MANAGEMENT DRAINAGE STRUCTURE WHERE THE STORMWATER MANAGEMENT BASIN IS TO BE USED FOR A TEMPORARY SEDIMENT BASIN DURING PROJECT CONSTRUCTION.
2. GRADE STORMWATER MANAGEMENT BASIN AS SHOWN IN PLANS.
3. ALL OPENINGS (IF ANY) IN SIDE OF STRUCTURE (OTHER THAN PERMANENT WATER QUALITY ORIFICE) ARE TO BE COVERED WITH SOLID METAL PLATES WHILE THE BASIN IS BEING USED FOR SEDIMENT CONTROL.
4. DEWATERING DEVICE AND COMPONENTS AND TEMPORARY METAL PLATES (IF ANY), AS SHOWN IN THE DETAIL, ARE TO BE REMOVED AND PERMANENT STEEL PLATE WITH WATER QUALITY ORIFICE IS TO BE INSTALLED WHEN BASIN IS NO LONGER NEEDED FOR SEDIMENT CONTROL.
5. SIMILAR DEVICE MAY ALSO BE USED ON OTHER STORMWATER MANAGEMENT DRAINAGE STRUCTURES.
6. COST OF TEMPORARY DEWATERING DEVICE AND TEMPORARY METAL PLATES (IF ANY) SHALL BE INCLUDED IN THE BID PRICE FOR STORMWATER MANAGEMENT DRAINAGE STRUCTURE.
7. THE TEMPORARY 8" DIA. POLYETHELENE DRAINAGE TUBING IS TO BE SOLID FOR THE LENGTH BELOW WET STORAGE ELEVATION AND IS TO BE PERFORATED ABOVE THE WET STORAGE ELEVATION. THE COUPLING IS TO BE WATERTIGHT.



STORMWATER MANAGEMENT (SWM) DETAILS

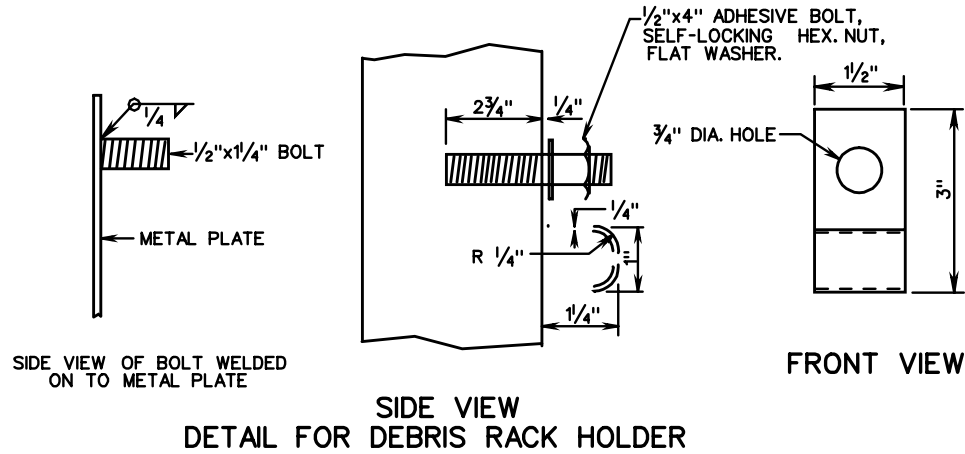

1. COST OF DEBRIS RACK, METAL PLATE, AND DEBRIS RACK HOLDER TO BE INCLUDED IN THE BID PRICE FOR THE SWM DRAINAGE STRUCTURE.
2. DEBRIS RACK MAY BE FABRICATED FROM WELDED 3/8" DIAMETER BARS OR 1/2" THICK HIGH DENSITY POLYETHYLENE. METAL COMPONENTS OF DEBRIS RACK MUST NOT BE GALVANIZED.
3. DEBRIS RACK TO BE HINGED AS SHOWN OR CONTRACTOR MAY SUBSTITUTE A COMPARABLE DESIGN AS APPROVED BY THE ENGINEER.
4. THE LOCATION OF THE DEBRIS RACK HOLDER MAY BE ADJUSTED FOR VARIABLE CONDITIONS. WHEN HOLDER BOLT IS LOCATED ON THE METAL PLATE THE 1/2" DIA. BOLT LENGTH IS TO BE REDUCED 1/4" LG. AND WELDED TO THE PLATE. DEBRIS RACK HOLDER AND ALL HARDWARE IS TO BE GALVANIZED.

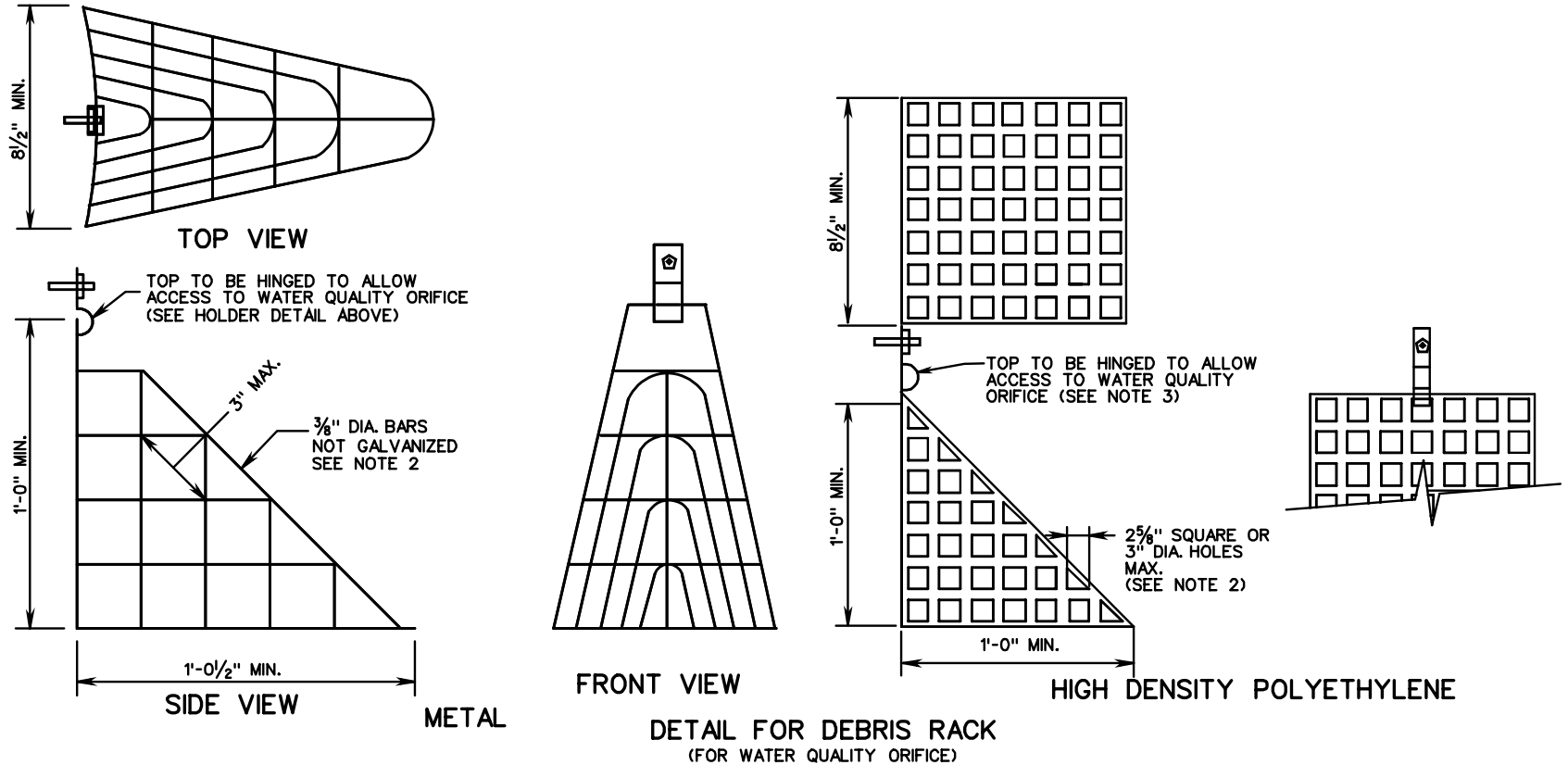

SPECIFICATION REFERENCE

302

STORMWATER MANAGEMENT (SWM) DETAILS
DEBRIS RACK, METAL PLATE, WATER QUALITY ORIFICE, CONCRETE CRADLE
(FOR SWM DRAINAGE STRUCTURES, SWM RISER PIPES AND SWM DAMS)
 VIRGINIA DEPARTMENT OF TRANSPORTATION

VDOT

ROAD AND BRIDGE STANDARDS

REVISION DATE

SHEET 2 OF 5

114.05

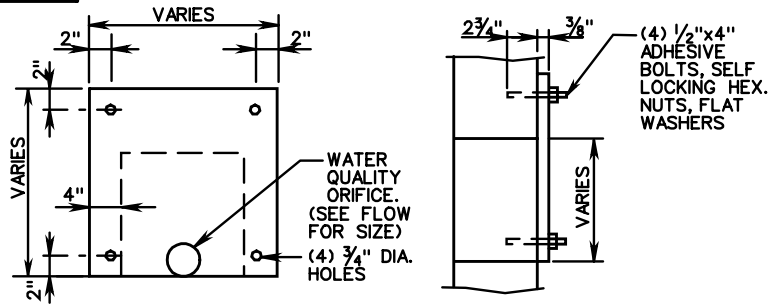

SWM DAM METAL PLATE DETAIL
(NOT GALVANIZED)

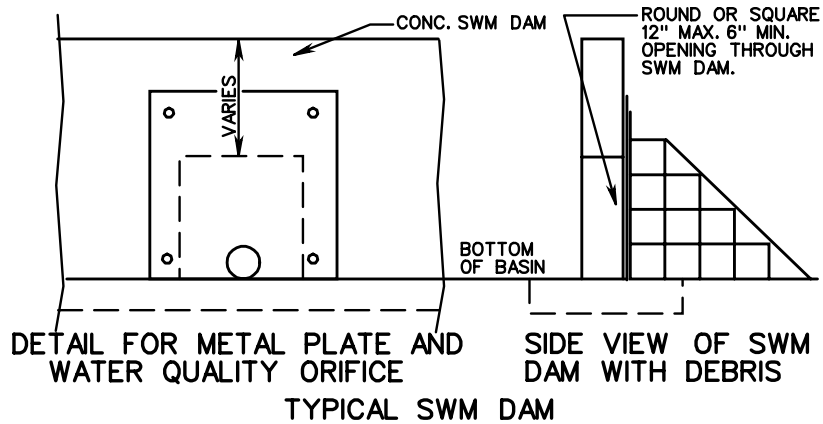

TYPICAL SWM DAM

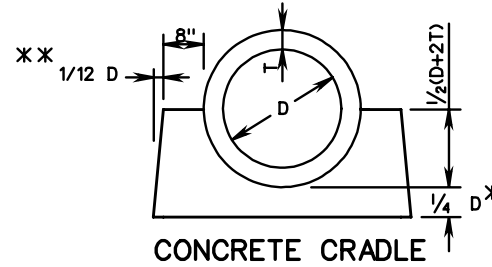

PIPE SIZE INCHES	CRADLE BOTTOM WIDTH (INCHES)	CRADLE HEIGHT (INCHES)	CRADLE TOP WIDTH (INCHES)	INCREMENT, IN CUBIC YARDS, PER LINEAR FOOT OF PIPE
12	34	14	32	0.093
15	38	15.75	35.5	0.110
18	42	17.5	39	0.129
24	50	21	46	0.168
30	58	26	53	0.233
36	66	31	60	0.307
42	74	36	67	0.390

CONCRETE SHALL BE CLASS A3 BUT NOT LESS THAN 6"
 * IF THE PIPE IS LAID IN AN EXCAVATED TRENCH, THEN THE SIDE WALLS MAY CONFORM TO THE TRENCH SHAPE (IE THE TRENCH MAY BECOME THE CRADLE FORM).
 CONCRETE CRADLE IS TO BE INSTALLED UNDER THE ENTIRE LENGTH OF CULVERT AT EACH STORMWATER MANAGEMENT BASIN.
 CONCRETE CRADLE IS TO BE PAID FOR AS MISCELLANEOUS CONCRETE AND SUMMARIZED IN CUBIC YARDS FOR EACH PIPE LOCATION

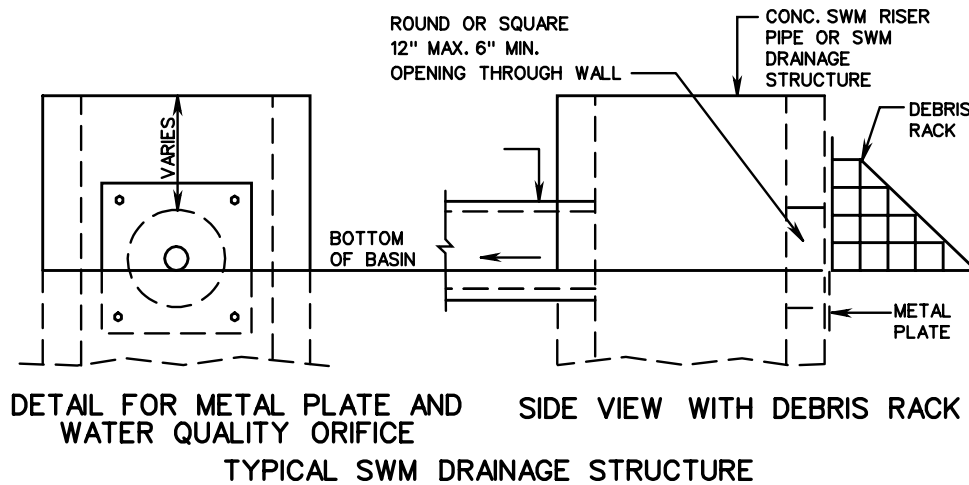
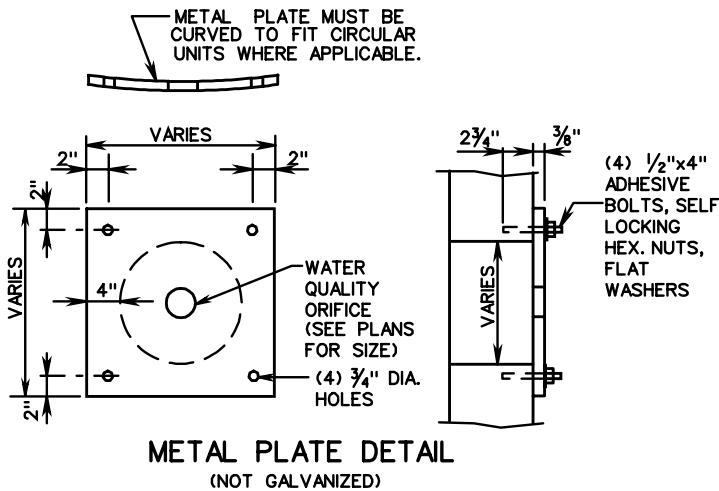

TYPICAL SWM DRAINAGE STRUCTURE

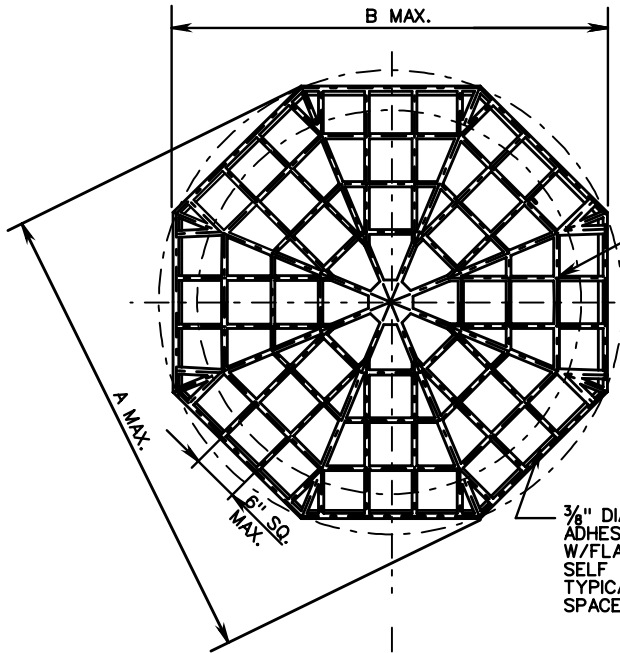

3/8" DIA. X 6" LG. ADHESIVE BOLTS W/FLAT WASHERS AND SELF LOCKING NUTS TYPICAL 8 PLACES-EQUALLY SPACED ON AN "E" DIA. B.C.

LOCKABLE ACCESS DOOR W/HINGE, MIN. 2' x 2' CLEAR OPENING SEE NOTE 1

3/8" DIA. X 6" LG. ADHESIVE BOLTS W/FLAT WASHERS AND SELF LOCKING NUTS. TYPICAL 8 PLACES-EQUALLY SPACED ON AN "E" DIA. B.C.

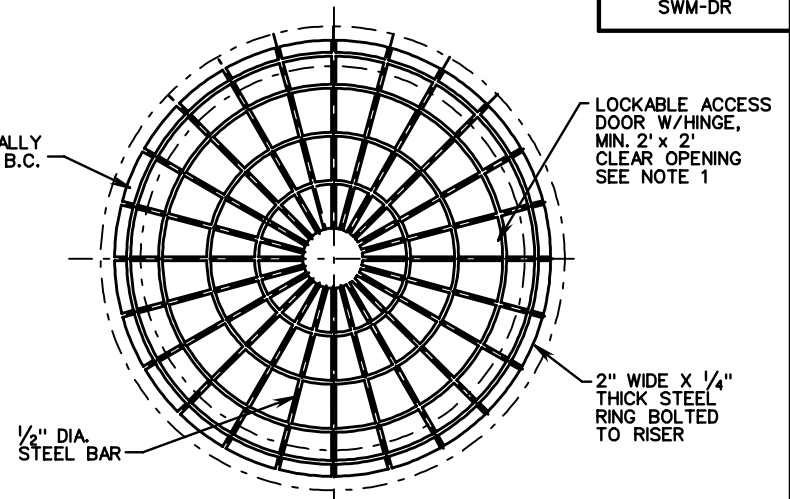

LOCKABLE ACCESS DOOR W/HINGE, MIN. 2' x 2' CLEAR OPENING SEE NOTE 1

2" WIDE X 1/4" THICK STEEL RING BOLTED TO RISER

1/2" DIA. STEEL BAR

1/2" THICK STEEL PLATE

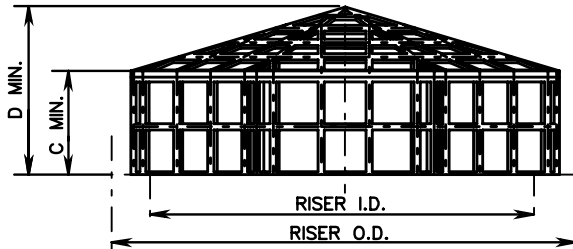

CIRCULAR STORMWATER MANAGEMENT DRAINAGE STRUCTURE

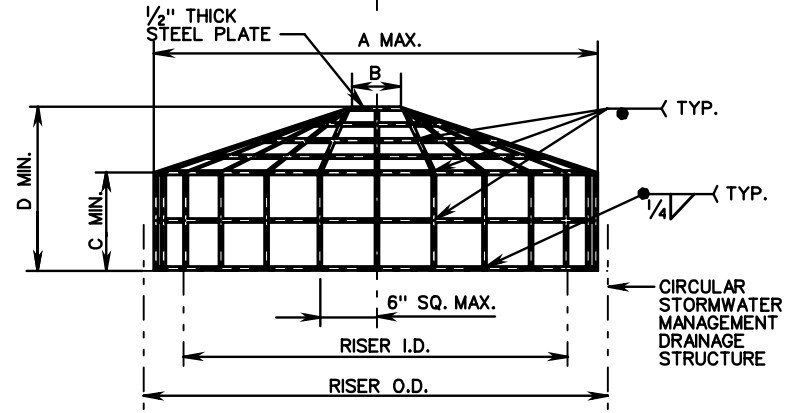

CIRCULAR STORMWATER MANAGEMENT DRAINAGE STRUCTURE

RISER		DIMENSION					APPROX. WT. (LBS.)
I.D.	O.D.	A	B	C	D	E	
24	30	31	28 ⁵ / ₈	7	11	27	24
36	44	45	41 ¹ / ₂	13	19	40	58
48	58	59	54 ¹ / ₂	13	21	53	86
60	72	73	67 ¹ / ₂	17	28	66	135
72	86	87	80 ³ / ₈	23	35	79	204
84	100	101	93 ³ / ₄	25	39	92	266
96	114	115	106 ¹ / ₄	22	38	105	305

HIGH DENSITY POLYETHYLENE

RISER		DIMENSION					APPROX. WT. (LBS.)	
I.D.	O.D.	A	B	C	D	E	SEGMENT	
24	30	30	6	7	10	27	15	46
36	44	42	6	13	18	40	22	82
48	58	55	9	13	20	53	29	120
60	72	68	9	17	26	66	36	169
72	86	81	9	23	34	79	42	227
84	100	94	12	25	37	92	49	290
96	114	107	12	22	36	105	56	341

METAL

NOTES:

1. A HINGED, LOCKABLE ACCESS DOOR SHALL BE PROVIDED ON ALL TRASH RACKS IF THE TOTAL WEIGHT OF THE TRASH RACK IS GREATER THAN 75 LBS OR IF THE TRASH RACK IS TO BE PLACED ON A SWM-1 WITH AN "H" DIMENSION GREATER THAN 7'-2".

2. ANTI-VORTEX PLATE IS TO BE USED WHEN SPECIFIED ON THE PLANS. COST OF FURNISHING AND PLACING THE ANTI-VORTEX PLATE IS TO BE INCLUDED IN THE BID PRICE FOR THE STRUCTURE.

SPECIFICATION REFERENCE

302

STORMWATER MANAGEMENT DETAILS TRASH RACK FOR SWM DRAINAGE STRUCTURES

VIRGINIA DEPARTMENT OF TRANSPORTATION

VDOT

ROAD AND BRIDGE STANDARDS

REVISION DATE

SHEET 4 OF 5

114.07

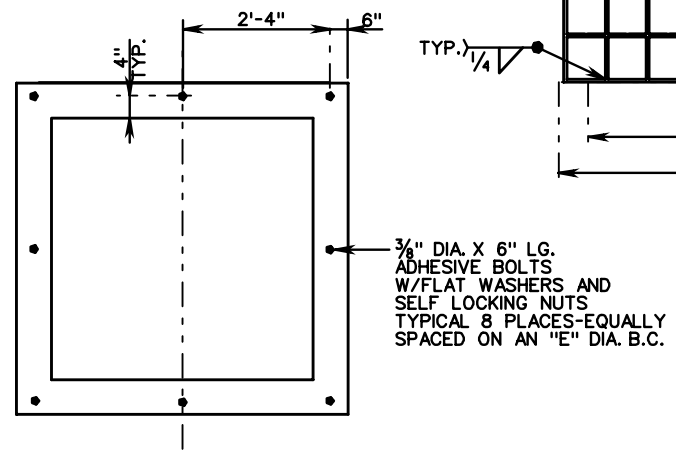
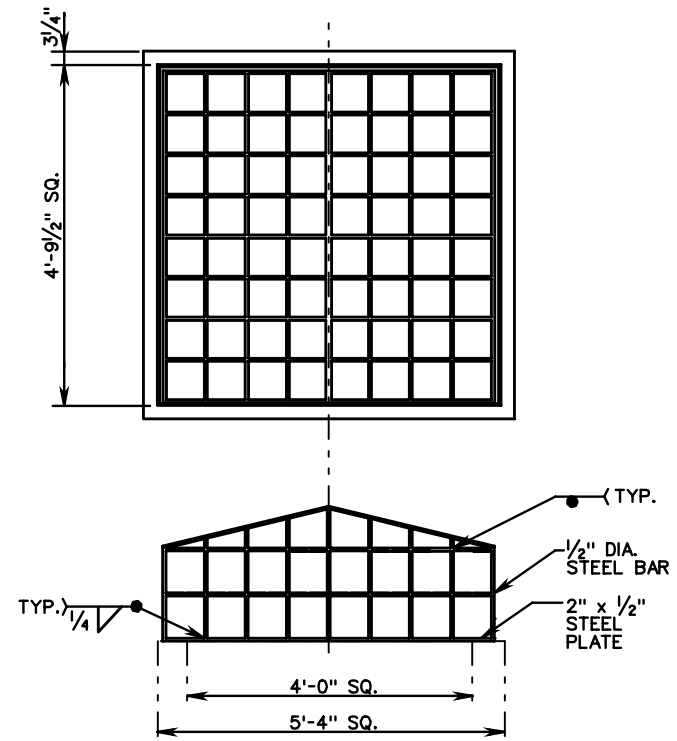
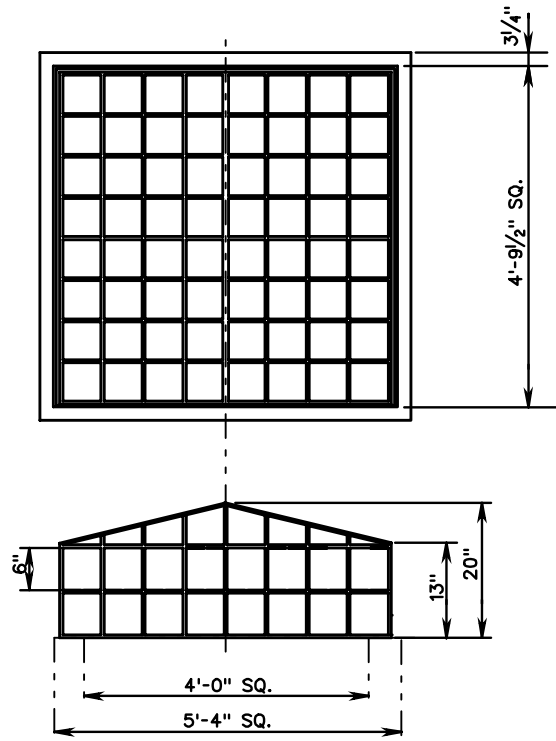

NOTE:
A HINGED, LOCKABLE ACCESS DOOR
WITH A MINIMUM 2' x 2' CLEAR OPENING,
SHALL BE PROVIDED ON ALL TRASH RACKS.

HIGH DENSITY POLYETHYLENE

METAL (STEEL)

APPROX. WT. (LBS.)
95

APPROX. WT. (LBS.)
188

STORMWATER MANAGEMENT DETAILS TRASH RACK FOR SWM DRAINAGE STRUCTURES

VIRGINIA DEPARTMENT OF TRANSPORTATION

SPECIFICATION
REFERENCE

302



ROAD AND BRIDGE STANDARDS

SHEET 5 OF 5

REVISION DATE

114.08

PROJECT MANAGER: *Chang, Name: 0001-0001-0001-0001*
 SURVEYED BY: *Chang, Name: 0001-0001-0001-0001*
 DESIGN: *Supplied, 01-11-2000, Name: 0001-0001-0001-0001*
 DESIGNED BY: *Chang, Name: 0001-0001-0001-0001*

ROADSIDE DEVELOPMENT

PERMID	STATE		PROJECT		SHEET NO.
	VA	00	0000-000-000	RW-000 C-000	
					0

CORE MIX

MIX	LBS./ACRES	DESCRIPTION
1	▲	* 100% CERTIFIED FINE FESCUE
2	▲	100% CERTIFIED TALL FESCUE
3	▲	50% CERTIFIED TALL FESCUE
4	▲	* 50% CERTIFIED FINE FESCUE
	▲	50% ORCHARDGRASS
	▲	50% CERTIFIED KENTUCKY BLUEGRASS
5	▲	100% BERMAUDGRASS
TEMPORARY		
3/1 - 5/16 and	50	50% CERTIFIED TALL FESCUE
8/16 - 3/1	50	50% BARLEY, WINTER RYE OR WINTER WHEAT
5/16 - 8/16	50	50% FOXTAIL MILLET
	50	50% CERTIFIED TALL FESCUE

ADDITIVES

TYPE	LBS./ACRES	DESCRIPTION
A	▲	100% LOVEGRASS
B	▲	100% BARLEY, WINTER RYE OR WINTER WHEAT
C	▲	100% FOXTAIL MILLET
D	▲	100% ANNUAL RYEGRASS
E	▲	100% CROWNVELTCH (LEGUME)
F	▲	100% SERICEA LESPEDEZA (LEGUME)
G	▲	100% BIRDFOOT TREFOL (LEGUME)
H	▲	
I	▲	
J	▲	
K	▲	

▲ ALL RATES TO BE SPECIFIED BY THE DISTRICT ROADSIDE MANAGER

* FINE FESCUES INCLUDE CHEWINGS, CREEPING RED, HARD, SHEEP

SECTION OF SEED LOCATIONS

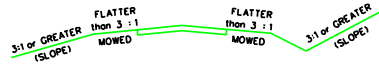

SEEDING SCHEDULE

SLOPES SEED MIX WITH ADDITIVE	MOWED SEED MIX WITH ADDITIVE	SLOPES SEED MIX WITH ADDITIVE	MOWED SEED MIX WITH ADDITIVE	SLOPES SEED MIX WITH ADDITIVE	MOWED SEED MIX WITH ADDITIVE
PROJECT NUMBERS					
* SPECIFY KIND OF FINE FESCUE					

NOTES:

APPROXIMATELY _____ ACRES WILL BE DISTURBED ON THIS PROJECT AND WILL REQUIRE THE ESTABLISHMENT OF GRASSES AND/OR LEGUMES.

* NOTES FOR FIELD USE ONLY

OVERSEEDING RATES SHALL BE 100 PERCENT OF THE SEED MIXTURE SUPPLIED WITHOUT FERTILIZER.

THE ENGINEER WILL REQUIRE THE CONTRACTOR TO PERFORM SUPPLEMENTAL SEEDING WHEN LESS THAN 75 PERCENT UNIFORM STAND OF THE PERMANENT GRASS SPECIFIED IN THE MIXTURES IS OBTAINED. (ANNUAL SPECIES SUCH AS RYE AND MILLET ARE TEMPORARY VARIETIES AND REQUIRE SUPPLEMENTAL SEEDING.)

NOTES APPLY TO SCHEDULE

LEGUME SEED MIXES (BIRDFOOT TREFOL, CROWNVELTCH, AND SERICEA LESPEDEZA) AND WEEPING LOVEGRASS SHALL NOT BE USED ON SHOULDERS AND OTHER LOCATIONS FLATTER THAN 3:1 SLOPE.

LEGUME SEED SHALL BE INOCULATED WITH THE APPROPRIATE STRAIN AND RATE OF BACTERIA FOR HYDROSEEDING, USE FIVE TIMES THE DRY SEEDING RATE OF INOCULATE.

A TEMPORARY MIX OR EROSION CONTROL MULCH, AS DIRECTED BY THE ENGINEER, IS TO BE USED ONLY ON AREAS THAT ARE TO BE REGRADED OR LATER DISTURBED, IF LEFT DORMANT FOR MORE THAN 15 DAYS.

EROSION CONTROL MULCH, AS DIRECTED BY THE ENGINEER, IS TO BE USED ON AREAS THAT ARE TO BE LEFT DORMANT FOR MORE THAN 15 DAYS BETWEEN DECEMBER 1 AND FEBRUARY 28.

EROSION CONTROL MULCH, AS LISTED ON THE VDOT APPROVED PRODUCTS LIST, SHALL BE APPLIED IN ACCORDANCE WITH THE MANUFACTURER'S RECOMMENDATIONS.

EROSION CONTROL MULCH SHALL PROVIDE 100 PERCENT COVERAGE OF ALL DENUDING AREAS. SPRING & SUMMER AND FALL & WINTER DEFINED FOR THE PURPOSE OF DETERMINING WHETHER MULCHED OR UNMULCHED BERMAUDGRASS AND SERICEA LESPEDEZA SEED IS REQUIRED:

SPRING & SUMMER 4/1 - 9/15 - USE MULCHED SEED
 FALL & WINTER 9/15 - 4/1 - USE UNMULCHED SEED

TYPE I MULCH (STRAW) TO BE USED ON NEWLY SEEDED AREAS ADJACENT TO ALL WATERWAYS, WETLANDS, SWAMPS, OR ANY AREA IN WHICH DRAINAGE FLOWS TOWARD AREAS UNDER THE JURISDICTION OF THE ENVIRONMENTAL REGULATORY AGENCIES.

TYPE I MULCH SHALL BE APPLIED TO PROVIDE A MINIMUM 90 PERCENT COVERAGE.

TYPE I MULCH SHALL BE TACKED WITH FIBER MULCH AT THE RATE OF 750 LBS. PER ACRE AND/OR MULCH TACKIFIER.

TYPE II MULCH (FIBER MULCH) MAY BE SUBSTITUTED FOR TYPE I MULCH AT THE RECOMMENDATION OF THE DISTRICT ROADSIDE MANAGER.

TYPE II MULCH SHALL BE APPLIED AT A RATE OF 1500 LBS. (NET DRY WEIGHT) PER ACRE TO PROVIDE A MINIMUM OF 90 PERCENT COVERAGE, AND SHALL BE APPLIED IN A SEPARATE APPLICATION.

ALL TOPSOIL IS TO BE FREE OF HARD LUMPS, CLODS, ROCKS AND FOREIGN DEBRIS AND IS TO BE HAND RAKED TO TIE INTO EXISTING LAWS.

ALL SEED MUST BE IN CONFORMANCE WITH VDOT SEED SPECIFICATIONS FOR GRASSES & LEGUMES AND BE PROVIDED AT THE PROJECT SITE IN BAGS NOT OPENED AND LABELED FOR USE ON VDOT PROJECTS WITH A GREEN TAG CERTIFYING INSPECTION BY THE VIRGINIA CROP IMPROVEMENT ASSOCIATION.

MIX REQUIREMENTS THIS PROJECT

RECOMMENDATIONS FOR THE APPLICATION OF SEED MIXTURES (CORE MIX AND ADDITIVES), FERTILIZER, LIME, ETC., ARE TO BE OBTAINED FROM THE DISTRICT ROADSIDE MANAGER.

ROADSIDE DEVELOPMENT SUMMARY

PROJECT NUMBERS	TOPSOIL 2" CLASS		REGULAR SEED	OVER SEEDING	LIME	FERT. 15-30-15	LEGUME SEED	LEGUME OVER SEEDING	TEMPORARY SEEDING
	A	B							
	ACRES	LBS.	LBS.	LBS.	TONS	TONS	LBS.	LBS.	LBS.

⊗ DENOTES ITEMS TO BE PAID FOR ON BASIS OF PLM QUANTITIES IN ACCORDANCE WITH CURRENT ROAD AND BRIDGE SPECIFICATIONS.

PROJECT	SHEET NO.
0000-000-000	0

PROJECT MANAGER <Project_Mgr_Name.(000) 000-0000 (District)>
 SURVEYED BY <Surveyor_Name.(000) 000-0000 (District)>
 DESIGN SUPERVISED BY <Supervisor_Name.(000) 000-0000 (District)>
 DESIGNED BY <Designer_Name.(000) 000-0000 (District)>

EROSION CONTROL SUMMARY

REVISED	STATE	ROUTE	STATE	PROJECT	SHEET NO.
	VA.	00		0000-000-000, RW-000 C-000	0

DESIGN FEATURES RELATING TO CONSTRUCTION OR TO REGULATION AND CONTROL OF TRAFFIC MAY BE SUBJECT TO CHANGE AS DEEMED NECESSARY BY THE DEPARTMENT

Sheet Number	Temp. Diversion Channel Lining CL-A TD-CL		Temp. Diversion Channel Lining CL-B TD-CL		Erosion Control Mulch	Protective Covering EC-2	Soil Stabilization Mat EC-3			Rock Check Dam Type I EC-4	Rock Check Dam Type II EC-4	Temporary Silt Fence EC-5	Temporary Filter Barrier EC-5	Drop Inlet Silt Trap EC-6		Temp. Sediment Basin Excavation	Siltation Control Excavation	Temp. Sediment Riser Pipe						Dewatering Basin EC-8	Temporary Berm ESC-INS *	Temporary Construction Entrance ESC-INS *	Slope Drain ESC-INS		Erosion Control Stone EC-1, Class I	Brush Silt Barrier ESC-INS *	Turbidity Curtain, Pervious	Turbidity Curtain, Impervious	
	Sq. Yd.	Sq. Yd.	Sq. Yd.	Sq. Yd.			Sq. Yd.	Sq. Yd.	Sq. Yd.					Sq. Yd.	Ea.			Ea.	L.F.	L.F.	Ea.	Ea.	L.F.				L.F.	L.F.					L.F.
Phase I																																	
Subtotal																																	
Phase II																																	
Subtotal																																	
Total																																	

* Not a pay item.

PROJECT MANAGER _____
 SURVEYED BY _____
 DESIGN SUPERVISED BY _____
 DESIGNED BY _____

DESIGN FEATURES RELATING TO CONSTRUCTION OR TO REGULATION AND CONTROL OF TRAFFIC MAY BE SUBJECT TO CHANGE AS DEEMED NECESSARY BY THE DEPARTMENT

REVISED	STATE	FEDERAL AID	ROUTE	STATE	SHEET NO.
	VA.	PROJECT		PROJECT	

DETAIL NO. 1

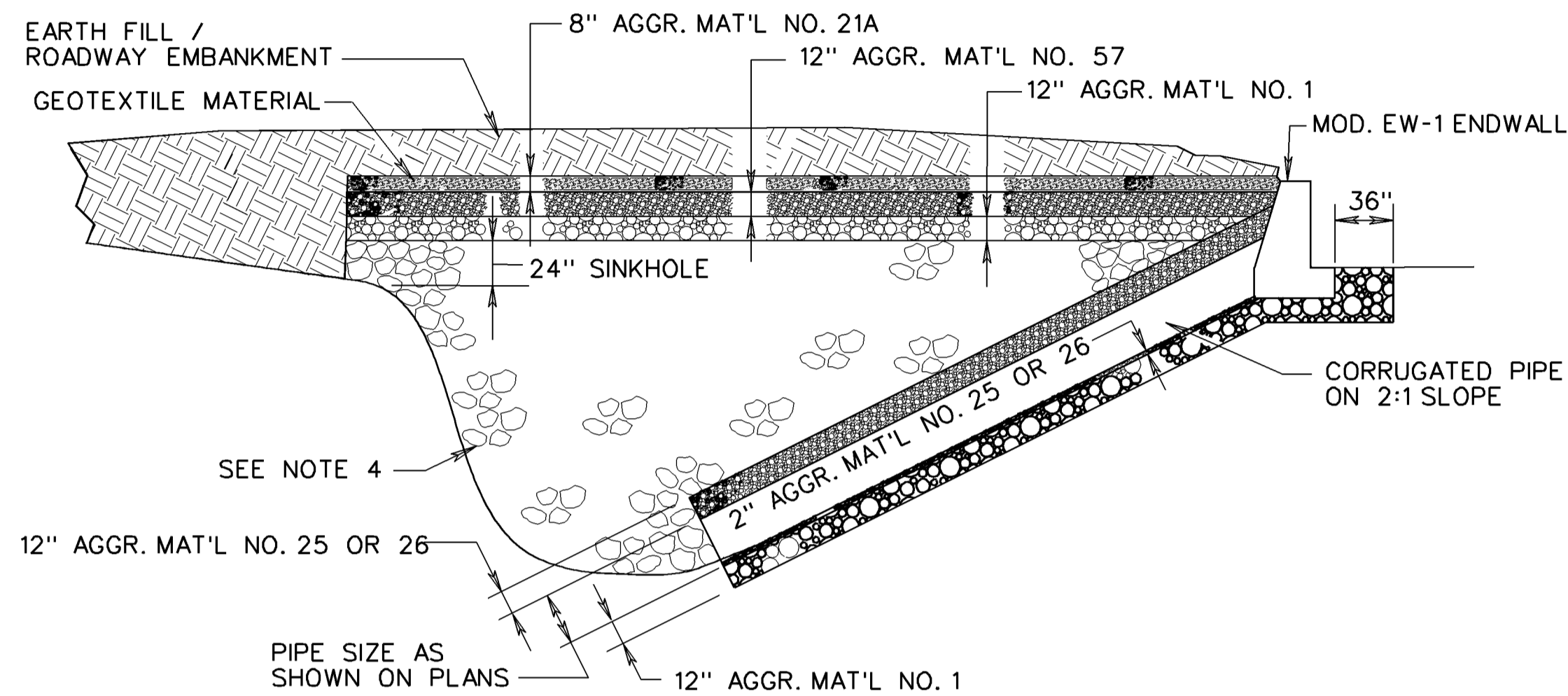

REMOVE ALL FOREIGN MATTER INCLUDING TRASH, REFUSE OR OTHER WASTE MATERIALS. EXCAVATE THE BOTTOM OF THE SINK TO ROCK, EXCAVATE THE SIDES (BACK, AHEAD, AND TOWARD TOE OF FILL SLOPE) TO AN ANGLE OF REPOSE OF 27° (2:1 SLOPE) FROM THE BOTTOM PLANE OF THE SINK. INSTALL A PIPE OF SUFFICIENT LENGTH TO INSURE POSITIVE DRAINAGE INTO THE SINK AT THE TOE OF FILL SLOPE. BED THE PIPE WITH 12" OF AGGREGATE MATERIAL NO. 1 OVERLAIED BY 2" OF AGGREGATE MATERIAL NO. 25 OR 26 FOR A LEVELING COURSE. PLACE 12" AGGREGATE MATERIAL NO. 25 OR 26 ALONG THE SIDES AND TOP OF THE PIPE FOR PROTECTION AGAINST THE BACKFILL. BACKFILL WITH DRY RIP RAP, CLASS II TO A HEIGHT OF 24" ABOVE ORIGINAL GROUND AS SHOWN, CAP WITH 12" AGGREGATE MATERIAL NO. 1, 12" AGGREGATE NO. 57 AND 8" AGGREGATE MATERIAL NO. 21A. OVERLAY AGGREGATE MATERIAL WITH GEOTEXTILE MATERIAL AND BACKFILL WITH EARTH FILL AS NEEDED.

DETAIL NO. 2

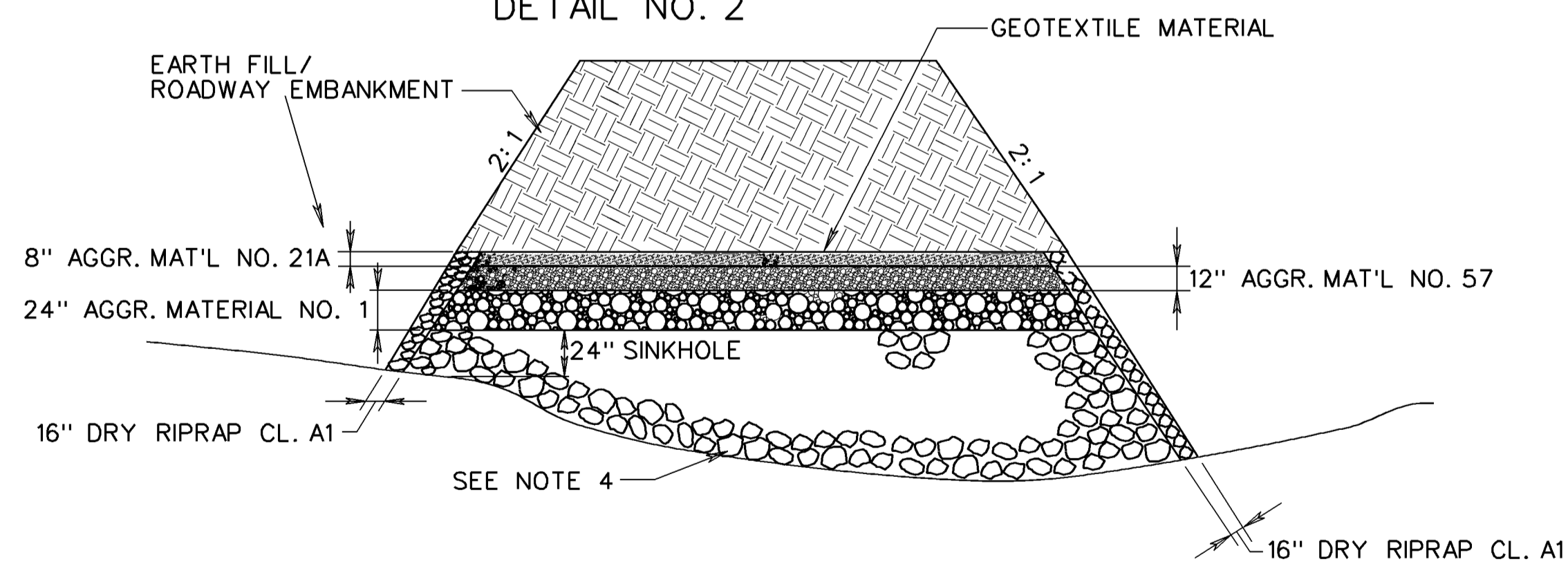

REMOVE ALL FOREIGN MATTER INCLUDING ALL VEGETATION, TRASH, REFUSE OR OTHER WASTE MATERIALS. EXCAVATE ALL UNSTABLE SOILS FROM THE SIDES AND BOTTOM OF THE SINK. BACKFILL WITH DRY RIP RAP, CLASS II TO A HEIGHT OF 24" ABOVE THE SURFACE DRAINAGE LINE. CAP WITH 24" AGGREGATE MATERIAL NO. 1, 12" AGGREGATE MATERIAL NO. 57 AND 8" AGGREGATE MATERIAL NO. 21A. A HEAVY VIBRATOR SHALL BE USED TO STABILIZE THE RIP RAP AND THE AGGREGATE MATERIAL AS EACH COURSE IS PLACED. PLACE A LAYER OF GEOTEXTILE MATERIAL ABOVE THE AGGREGATE MATERIAL COURSES. EARTH FILL IS BE PLACED ABOVE THE GEOTEXTILE FABRIC AS NEEDED. OVERLAY EXPOSED RIP RAP/AGGREGATE FILL SLOPES WITH 16" DRY RIPRAP CLASS A1.

DETAIL NO. 3

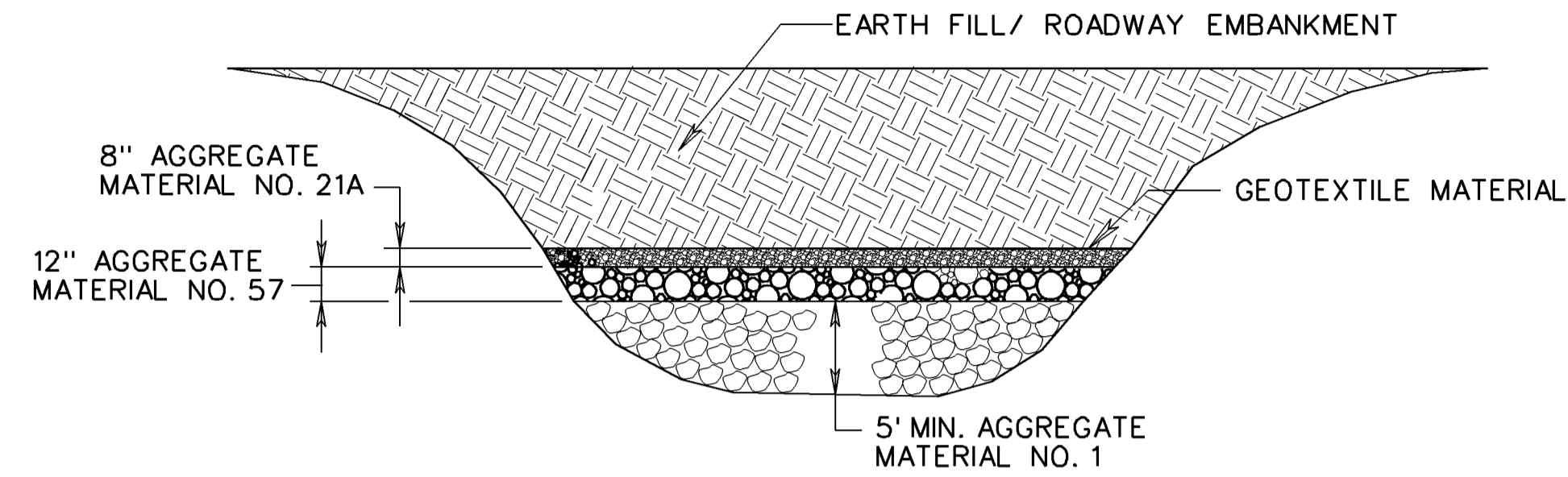

TREATMENT SHALL INCLUDE CLEARING AND GRUBBING, STRIPPING TOPSOIL AND REMOVING EXCESS ORGANIC MATERIAL. ALL FOREIGN MATTER INCLUDING TRASH, WHITE GOODS AND OTHER REFUSE OR WASTE MATERIALS SHALL BE REMOVED. STRIPPED SINKHOLE SHALL BE BACKFILLED WITH A MINIMUM OF 5' DEPTH OF NO. 1 AGGREGATE OVERLAIED WITH 12" OF NO. 57 AGGREGATE AND 8" OF AGGREGATE MATERIAL NO. 21A. THE AGGREGATE SHALL BE OVERLAIED WITH A GEOTEXTILE MATERIAL.

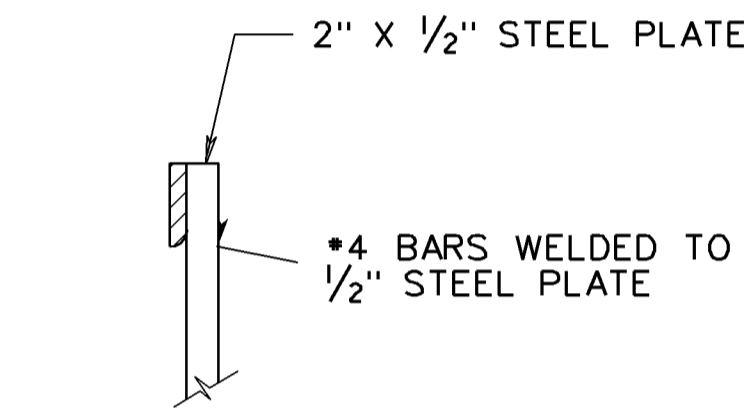

SECTION A-A

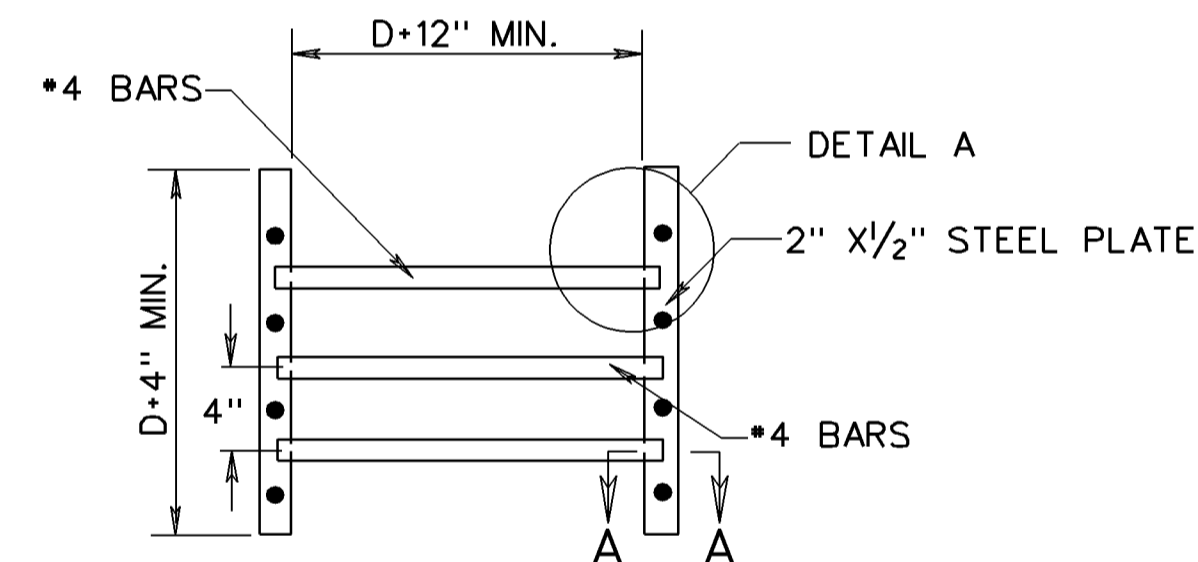

GRATE ASSEMBLY AS SHOWN SHALL BE GALVANIZED AFTER FABRICATION.

SPECIAL DESIGN GRATE DETAIL

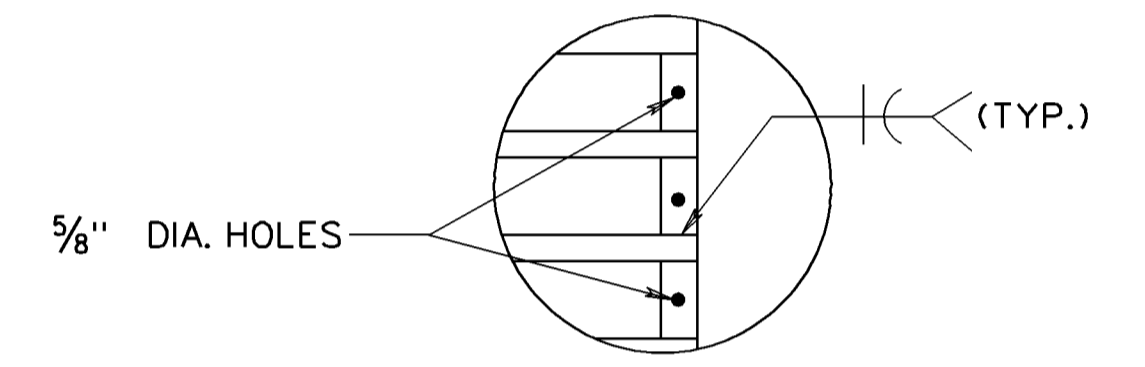

DETAIL A

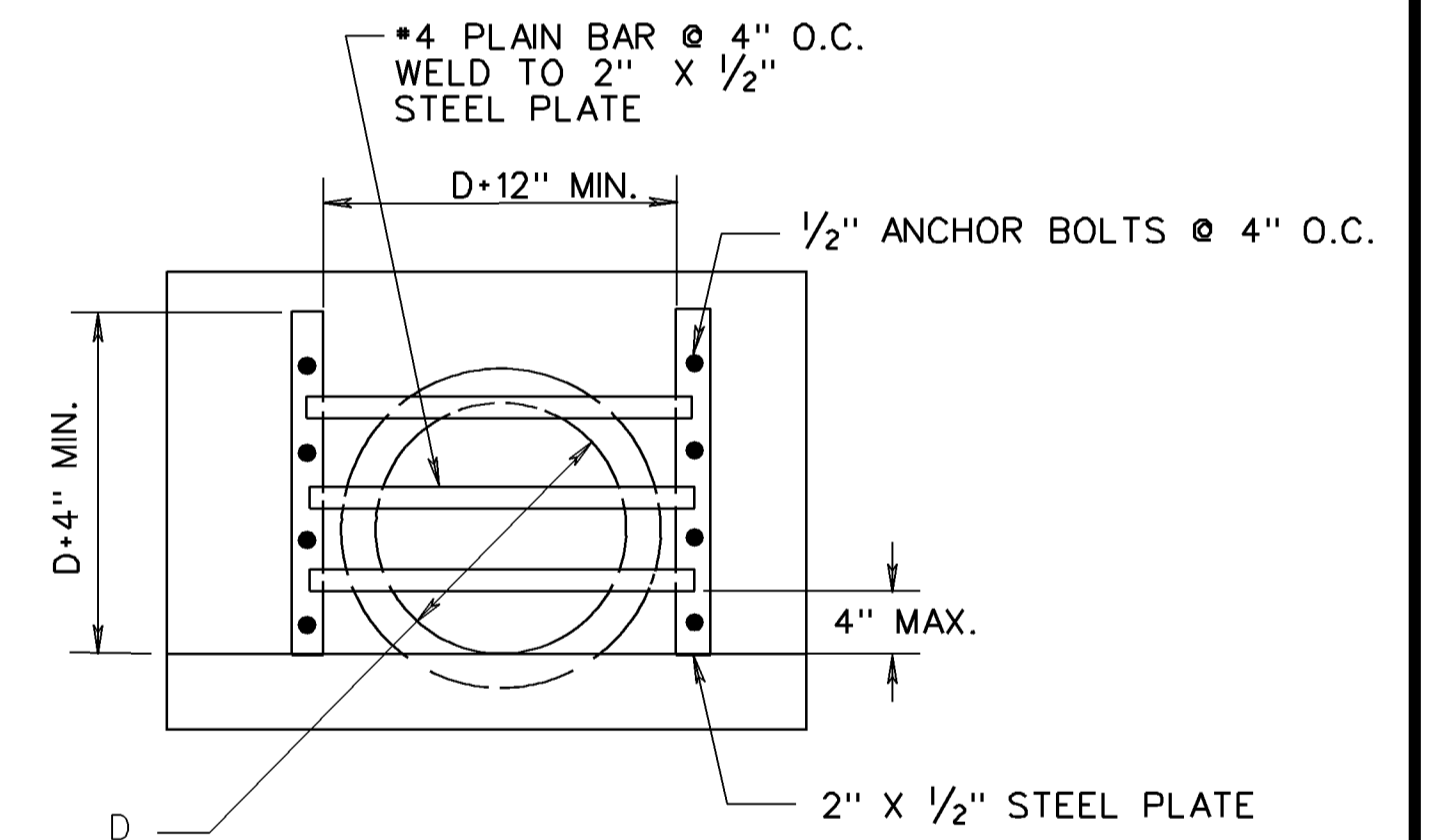

ATTACHMENT TO STANDARD EW-1

FOR USE ON STANDARD EW-1

GENERAL NOTES:

1. PRIOR TO ANY SINKHOLE EXCAVATION THE CONTRACTOR SHALL CONTACT THE DISTRICT MATERIALS ENGINEER.
2. EACH SINKHOLE SHOULD BE TREATED ON AN INDIVIDUAL, SITE SPECIFIC BASIS DEPENDING ON THE CONDITIONS IN THE AREA.
3. CONSECUTIVE LAYERS OF AGGREGATE SHALL BE PLACED IN SUCH A MANNER AS TO PREVENT FUTURE MIGRATION OF SMALLER STONES INTO LARGER STONES.
4. WHEN THE DEPTH OF A SINKHOLE OR A DEPRESSION IS LESS THAN 10', AGGREGATE MATERIAL NO. 1 SHALL BE USED FOR BACKFILL IN LIEU OF DRY RIP-RAP. THE AGGREGATE MATERIAL NO. 1 SHALL EXTEND TO A HEIGHT OF 24" ABOVE THE SURFACE DRAINAGE LINE. THE AGGREGATE MATERIAL NO. 1 SHALL BE CAPPED WITH NO. 57 AGGREGATE, NO. 21A AGGREGATE, AND GEOTEXTILE MATERIAL AS NOTED ON THE APPLICABLE DETAIL.
5. EXCAVATION NECESSARY FOR PLACEMENT OF THE SINKHOLE FILL SHALL BE MEASURED AND PAID FOR AS REGULAR EXCAVATION IN ACCORDANCE WITH THE SECTION 303 OF THE SPECIFICATIONS. ALL OTHER MATERIAL SHALL CONFORM TO AND BE MEASURED AND PAID FOR IN ACCORDANCE WITH THE APPLICABLE SECTIONS.
6. GEOTEXTILE MATERIAL SHALL CONFORM TO SECTION 245.03(B) OF THE SPECIFICATIONS
7. BASIS OF PAYMENT FOR SPECIAL DESIGN GRATE WILL BE MEASURED AND PAID FOR AT THE CONTRACT UNIT PRICE PER EACH. THIS PRICE SHALL INCLUDE ALL COST FOR FURNISHING THE FABRICATED GRATE AND ITS INSTALLATION. ALL HARDWARE, EQUIPMENT, LABOR, TOOLS, GALVANIZING AND INCIDENTALS NECESSARY TO COMPLETE THE WORK SHALL BE INCLUDED IN THE UNIT PRICE PER EACH COST.

NEW 11/02
 SPECIAL DESIGN SECTION
 DRAWING NO. 2944

SINKHOLE TREATMENT DETAILS

PLAN NO.	PROJECT	FILE NO.	SHEET NO.
----------	---------	----------	-----------

PROJECT MANAGER <Project_Mgr_Name (000) 000-0000 (District)>
 SURVEYED BY <Surveyor_Name (000) 000-0000 (District)>
 DESIGN SUPERVISED BY <Supervisor_Name (000) 000-0000 (District)>
 DESIGNED BY <Designer_Name (000) 000-0000 (District)>

REVISED	STATE	STATE		SHEET NO.
	ROUTE	PROJECT		
	VA.	00	0000-000-000, RW-000 C-000	0

STORMWATER POLLUTION PREVENTION PLAN (SWPPP) GENERAL INFORMATION SHEET

The SWPPP General Information sheets are to be completed and included in the construction plan set (or other such documents) for land disturbance activities that disturb an area equal to or greater than 10,000 square feet, or equal to or greater than 2,500 square feet in the area defined as Tidewater, Virginia in the Virginia Chesapeake Bay Preservation Act.

✱ Denotes information that is to be provided/completed by the contractor or the VDOT RLD, as appropriate.

SECTION I GENERAL INFORMATION

1. Activity Description - (insert appropriate text)
2. This land disturbance activity site is located in (insert the appropriate County/City) and approximately (insert the appropriate number to the nearest one tenth acre) acres will be disturbed by excavation, grading or other construction activities. (Note: The disturbed area includes an estimate for any anticipated offsite support facilities, i.e., borrow sites, disposal areas, storage areas, etc.)
3. This land disturbance activity (select requires or does not require, based on land disturbance value) coverage under the VSMP General Permit For Discharges Of Stormwater From Construction Activities as issued by the DCR.
4. The erosion and sediment control (ESC) and stormwater management (SWM) plans for this land disturbance activity have been developed in accordance with VDOT's Erosion and Sediment Control and Stormwater Management Standards and Specifications as approved annually by the Department of Conservation and Recreation.
5. (Insert person's name and job title) is designated as the RLD for this land disturbance activity.
6. Critical areas (e.g., wetlands, surface water bodies, etc) adjacent to this land disturbance activity site and not otherwise identified in the construction plan set (or other such documents) are as follows: (insert appropriate text)
7. Stormwater run-off from the disturbed areas of this land disturbance activity will flow into the following streams: (insert appropriate stream names; for any unnamed tributary, identify what named stream it flows into, e.g., Unnamed Tributary to Bull Run)
8. Locations where stormwater discharges from this land disturbance activity site to a surface water are identified in the construction plan set (or other such documents).

6. Locations where stabilization practices are expected to occur are identified in the construction plan set (or other such documents) for this land disturbance activity.
7. A description of interim and permanent stabilization practices for the site are identified in the applicable sections of the documents identified in the Note 1 of Section III.
- ✱ 8. A record of the dates when major grading activities occur, when construction activities temporarily or permanently cease on a portion of the site, and when stabilization measures are initiated will be maintained in the SWPPP documents for this land disturbance activity.
9. A description of structural practices to divert flows from exposed soils, retain/detain flows or otherwise limit runoff and the discharge of pollutants from exposed areas of the construction site are identified in the applicable sections of the documents identified in Note 1 of Section III.
10. A description and schedule of procedures to maintain vegetation, erosion and sediment control measures and other protective measures in good and effective operating conditions during construction are identified in Section 107.16 (as amended and/or revised) and 303.03 of the VDOT R&B Specifications.
11. All engineering calculations supporting the design of erosion and sediment control measures are contained in the project drainage file located in the (insert appropriate location, i.e., VDOT Central Office Hydraulics Section or the VDOT (specify) District Hydraulics Section or the VDOT (specify) Residency Office) and will be made available for review upon request during normal working business hours.
12. The temporary erosion and siltation control items shown on the Erosion and Sediment Control (ESC) Plan for this project are intended to provide a general plan for controlling erosion and sediment within the project limits. The ESC Plan is based on field conditions at the time of plan development and an assumed sequence of construction for the project. The contractor, in conjunction with the VDOT Project Engineer and/or ESC Inspector, shall adjust the location, quantity and type of erosion and sediment control items required based on the actual field conditions encountered at the time of construction and the actual scheduling and sequencing of the construction activities. Significant changes to the proposed ESC Plan (e.g., those that require an engineering analysis) shall be submitted to the applicable District Hydraulics Engineer for review and approval. Any changes to the proposed ESC Plan must be noted on a designated plan set (Record Set) which shall be retained on the project site and made available upon request during normal working business hours.

SECTION II EROSION AND SEDIMENT CONTROL

1. The following variances to the Virginia ESC Regulations have been approved by DCR for this land disturbance activity: (list all approved variances; include a brief description of the variance, the date approved and the approving DCR Office)
- ✱ 2. The intended sequence and timing of activities that disturb soils at the site (e.g., grubbing, excavation, grading, utilities and infrastructure installation, etc.) shall be provided by the contractor in accordance with Section 108.03 of the VDOT R&B Specifications and will be maintained with the other SWPPP documents for this land disturbance activity.
3. Directions of stormwater flow and approximate slopes anticipated after major grading activities are identified in the construction plan set (or other such documents) for this land disturbance activity.
4. Areas of soil disturbance and areas of the site which will not be disturbed are identified in the construction plan set (or other such documents) for this land disturbance activity.
5. Locations of major structural and nonstructural ESC measures identified in the SWPPP, including those that will be permanent controls that will remain after construction activities have been completed, are identified in the construction plan set (or other such documents) for this land disturbance activity.

13. The areas beyond the project's construction area are to be protected from siltation. Perimeter controls such as filter barrier, silt fence, diversion dikes, turbidity curtains, etc. shall be installed prior to any grubbing operations or other earth moving activities.
14. Temporary earthen structures such as dikes and berms are to be stabilized immediately upon installation. Stabilization may include temporary or permanent seeding, riprap, aggregate, sod, mulching, and/or soil stabilization blankets and matting in conjunction with seeding.
15. All channel relocations are to be constructed during the earliest stage of construction and shall be constructed in accordance with all applicable permit requirements and shall be constructed in the dry wherever possible. Stabilization or vegetation shall be established before flow is redirected through the constructed area as directed by the Engineer.

ACRONYMS

DCR - Department of Conservation and Recreation
 ESC - Erosion and Sediment Control
 R&B - Road and Bridge
 RLD - Responsible Land Disturber
 SWM - Stormwater Management
 SWPPP - Stormwater Pollution Prevention Plan
 VSMP - Virginia Stormwater Management Program

	PROJECT 0000-000-000	SHEET NO. 0
--	-------------------------	----------------

PROJECT MANAGER <Project_Mgr_Name (000) 000-0000 (District)>
 SURVEYED BY <Surveyor_Name (000) 000-0000 (District)>
 DESIGN SUPERVISED BY <Supervisor_Name (000) 000-0000 (District)>
 DESIGNED BY <Designer_Name (000) 000-0000 (District)>

STORMWATER POLLUTION PREVENTION PLAN (SWPPP) GENERAL INFORMATION SHEET

The SWPPP General Information sheets are to be completed and included in the construction plan set (or other such documents) for land disturbance activities that disturb an area equal to or greater than 10,000 square feet, or equal to or greater than 2,500 square feet in the area defined as Tidewater, Virginia in the Virginia Chesapeake Bay Preservation Act.

✗ Denotes information that is to be provided/completed by the contractor or the VDOT RLD, as appropriate.

REVISED	STATE	STATE		SHEET NO.
		ROUTE	PROJECT	
	VA.	00	0000-000-000, RW-000 C-000	0

SECTION III SWPPP

1. All documents related to the SWPPP for this land disturbance activity shall be maintained at the activity site and shall be readily available for review upon request during normal working business hours. Such documents include, but are not limited to, the construction plans (or other such documents), the ESC Plan, the post construction SWM Plan (if applicable), the VDOT R&B Standards and Specifications, Supplemental Specifications, Special Provisions and Special Provision Copied Notes. Documents related to stormwater pollution prevention which are not a part of those documents referenced above, such as a copy of the VSMP Construction Permit coverage letter (when applicable), the DCR General Permit For Discharges Of Stormwater From Construction Activities (when applicable) and those required to be developed by the contractor for stormwater pollution prevention associated with any support facilities for this land disturbance activity are to be maintained at the activity site with the other SWPPP documents. Where no facilities are available at the activity site to maintain the SWPPP documents, they are to be kept by or with the designated RLD at a location convenient to the activity site where they would be made available for review upon request during normal business working hours.

2. Other than construction at the activity site, there are no discharges associated with industrial activity (e.g., from dedicated asphalt plants or dedicated concrete plants) produced by this land disturbance activity or (where applicable) covered by the VSMP General Permit For Discharges Of Stormwater From Construction Activities for this land disturbance activity.

✗ 3. Documents identifying the locations of off-site waste or borrow areas or material or equipment storage areas associated with or (where applicable) covered by the VSMP General Permit For Discharges Of Stormwater From Construction Activities for this land disturbance activity shall be provided by the contractor in accordance with Section 107.16 of the VDOT R&B Specifications and will be maintained with the other SWPPP documents for this land disturbance activity.

✗ 4. A description of all pollution control measures that will be implemented as a part of this construction activity to control pollutants in stormwater discharges are identified and described in the contractor supplied documents, the construction plan set (or other such documents) and applicable sections of the VDOT R&B Specifications and Standards, including but not limited to, Specifications 107.16 (as amended and/or revised), 303.03, 603, 604 and 606 and Standards 113.01 through 114.08. The name of the individual(s) or contractor(s) responsible for the installation and maintenance of the pollution control measures is included in the contractor supplied documents.

5. Requirements for the prevention of the discharge of solid materials, including building materials, garbage, and debris, to surface waters of the state, except as authorized by a Clean Water Act 404 permit, are contained in Sections 106.04, 107.02 and 107.16 (as amended and/or revised) of the VDOT R&B Specifications.

6. Requirements for compliance with applicable state or local waste disposal, sanitary sewer or septic system regulations are contained in Sections 106.04 and 107.18 of the VDOT R&B Specifications.

✗ 7. A description of construction and waste materials expected to be stored on-site or at off-site support facilities and a description of controls to reduce pollutants from these materials, including storage practices to minimize exposure of the materials to stormwater and practices for spill prevention and response, will be contained in documents supplied by the contractor and maintained with the other SWPPP documents for this land disturbance activity.

✗ 8. A description of potential pollutant sources from off site support areas and a description of controls and measures that will be implemented at those sites to minimize pollutant discharges will be contained in documents supplied by the contractor and maintained with the other SWPPP documents for this land disturbance activity.

✗ 9. By completing and submitting the SWPPP Certification form LD-445E, the RLD, or his authorized representative, certifies that all contractor supplied documents, identified herein, will be reviewed, approved and included with the other SWPPP documents for this land disturbance activity prior to implementation of work in those areas impacted by such information.

✗ 10. The name of the VDOT individual responsible for the inspection of the erosion and sediment control measures is identified on the LD-445E form which will be maintained with the other SWPPP documents for this land disturbance activity (Note: Individual shall be certified through the DCR ESC Inspector Certification Program).

11. For those land disturbing activities requiring coverage under the VSMP General Permit For The Discharge Of Stormwater From Construction Activities, the SWPPP shall be made available for review upon the request of the DCR, the EPA, local government officials or the operator of a municipal separate storm sewer system (MS4) receiving discharge from the construction site.

✗ 12. For those land disturbing activities requiring coverage under the VSMP General Permit For The Discharge Of Stormwater From Construction Activities, the VDOT RLD shall post, or have posted, a copy of the General Permit coverage letter and a copy of a completed LD-445B form, noting the name and contact information for the VDOT person responsible for the land disturbing activity and its SWPPP, outside the project's construction office along with other Federal and State mandated information. Where there is no construction office (e.g., a maintenance activity), the permit coverage letter and the LD-445B form is to be maintained with the other SWPPP documents for the land disturbing activity.

13. For those land disturbing activities requiring coverage under the VSMP General Permit For The Discharge Of Stormwater From Construction Activities on or after July 1, 2009 that have not been previously covered by a VSMP permit, the SWPPP shall be made available for review by the public upon request. Such reviews shall be at a time and publicly accessible location convenient to the VDOT and shall be scheduled during normal business hours and no less than once a month.

SECTION IV POST CONSTRUCTION STORMWATER MANAGEMENT

1. This land disturbance activity is exempt from the Stormwater Management Regulations because it disturbs less than 1 acre or less than 2500 square feet in an area designated as a Chesapeake Bay Preservation Area.

2. This activity is linear in nature and the following stormwater outfall locations are exempt from the requirements of the Virginia Stormwater Management Law because all of the following conditions are met (Note: Documentation must demonstrate that all three conditions (a-c) have been met and such documentation shall be maintained in the project drainage file located at the site identified in Note 6 of this Section):

- a. the land disturbance created by this activity at each listed outfall is less than one acre and,
- b. there are insignificant increases in peak flow rates at each listed outfall and,
- c. there is no existing or anticipated flooding or erosion problems downstream of the discharge point of each listed outfall. (List all applicable locations)

3. The following outfalls do not require a permanent SWM facility because, as a result of this land disturbance activity, the amount of additional impervious area draining to the outfall is less than 16% of the total right of way and permanent easement area draining to the outfall. (List all applicable locations)

4. For stormwater outfall locations not covered by Notes 2 and 3 of this Section, list the permanent SWM facilities proposed to meet the water quality/quantity requirements for this land disturbance activity in Section VI: (list each outfall location and the type of proposed permanent SWM facility, including any agreements for the use of off-site or regional stormwater facilities or payment into a DCR approved County/City Watershed Stormwater Management Plan fund).

5. A description of all post-construction stormwater management measures that will be installed during the construction process to control pollutants in stormwater discharges after construction operations have been completed is included in the construction plan set (or other such documents) for this land disturbance activity.

6. All engineering calculations supporting the design of the post-construction stormwater management measures, including an explanation of the technical basis used to select the practices, are contained in the project drainage file located in the (insert appropriate location, i.e., VDOT Central Office Hydraulics Section or the VDOT (specify) District Hydraulics Section or the VDOT (specify) Residency Office) and will be made available for review upon request during normal working business hours.

ACRONYMS

- DCR - Department of Conservation and Recreation
- ESC - Erosion and Sediment Control
- R&B - Road and Bridge
- RLD - Responsible Land Disturber
- SWM - Stormwater Management
- SWPPP - Stormwater Pollution Prevention Plan
- VSMP - Virginia Stormwater Management Program

PROJECT	SHEET NO.
0000-000-000	0

