

DETAILS OF TOWERS

**TYPE A**

TO BE USED WHEN VERTICAL DISTANCE BETWEEN GRADE AND INVERT OF PIPE IS PIPE DIAMETER PLUS 5'-4" OR GREATER (SEE NOTE 3).

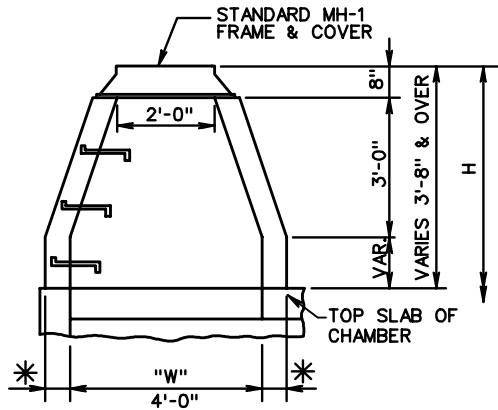

\* WALL THICKNESS TO BE 6" TO A DEPTH OF 10' AND 8" OVER 10'.

SECTION A-A

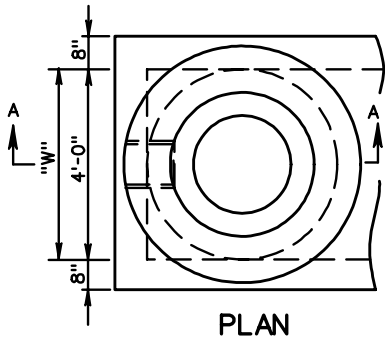

PLAN

**TYPE B**

TO BE USED WHEN VERTICAL DISTANCE BETWEEN GRADE AND INVERT OF PIPE IS PIPE DIAMETER PLUS 3'-2" TO 5'-4" (SEE NOTE 3).

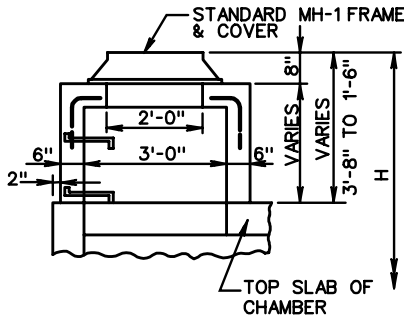

SECTION A-A

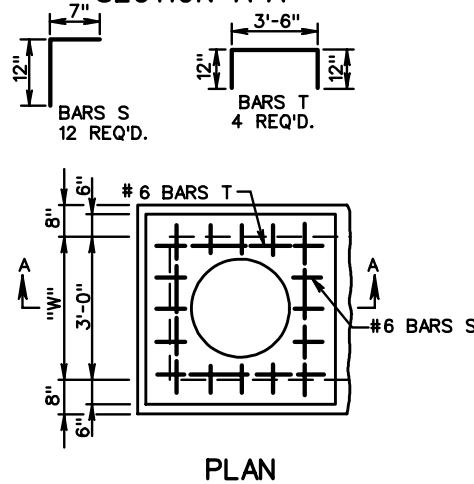

PLAN

**TYPE C**

TO BE USED WHEN DISTANCE BETWEEN GRADE AND INVERT OF PIPE IS PIPE DIAMETER PLUS 2'-4" TO 3'-2" (SEE NOTE 3).

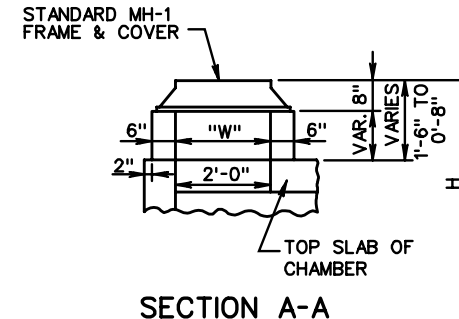

SECTION A-A

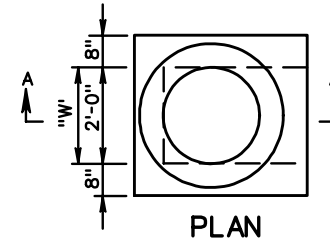

PLAN

NOTES:

1. PRECAST UNITS IN ACCORDANCE WITH STANDARD MH-2 MAY BE SUBSTITUTED FOR TYPE A TOWER SHOWN. IF SUBSTITUTED, PAYMENT WILL BE MADE AT THE CONTRACT UNIT PRICE, FOR CONCRETE AND STEEL BASED ON THE THEORETICAL QUANTITIES THAT WOULD HAVE BEEN REQUIRED TO BUILD THE TYPE A TOWER.
2. SEE STANDARD SL-1 FOR APPLICABILITY OF SAFETY SLABS.
3. INCREASE INDICATED DIMENSION BY ONE FOOT FOR USE WITH 72" DIAMETER PIPE.
4. CHAMBER AND TOWER QUANTITIES FOR CONCRETE AND REINFORCING STEEL MUST BE ADDED TO OBTAIN TOTALS.

QUANTITIES FOR TOWER \*\*

	TYPE A	TYPE B	TYPE C
CONCRETE	0.643 C.Y.	0.325 C.Y.	—
INCREMENT PER FOOT	0.262 TO 10' DEPTH 0.362 OVER 10'	0.259	0.145
REINFORCING STEEL	—	62 LBS.	—

\*\* QUANTITIES SHOWN ARE FOR MINIMUM TOWERS OF EACH TYPE. FOR TOWERS ABOVE MINIMUM HEIGHT INCREMENTS SHOWN PER FOOT MUST BE ADDED.



ROAD AND BRIDGE STANDARDS

SHEET 3 OF 4

REVISION DATE

106.12

JUNCTION BOX TOWER DETAILS FOR 48" - 72"  
PIPE CULVERTS MAXIMUM DEPTH (H) = 20'

VIRGINIA DEPARTMENT OF TRANSPORTATION

SPECIFICATION REFERENCE

105  
233  
302