

T-DI-5

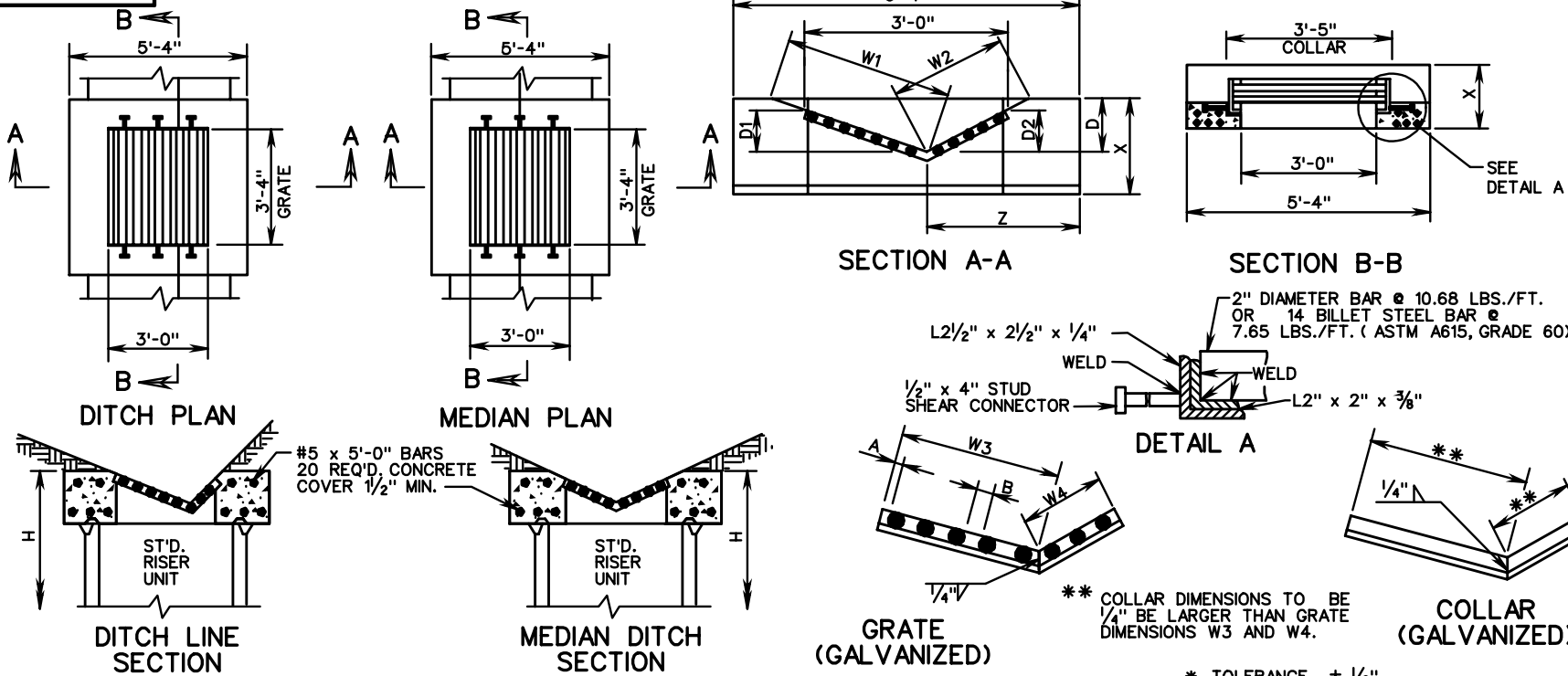

2" DIAMETER BAR @ 10.68 LBS./FT.
OR
14 BILLET STEEL BAR @
7.65 LBS./FT. (ASTM A615, GRADE 60).

L2 1/2" x 2 1/2" x 1/4"

WELD

1/2" x 4" STUD
SHEAR CONNECTOR

WELD

L2" x 2" x 3/8"

** COLLAR DIMENSIONS TO BE
1/4" BE LARGER THAN GRATE
DIMENSIONS W3 AND W4.

* TOLERANCE ± 1/2"

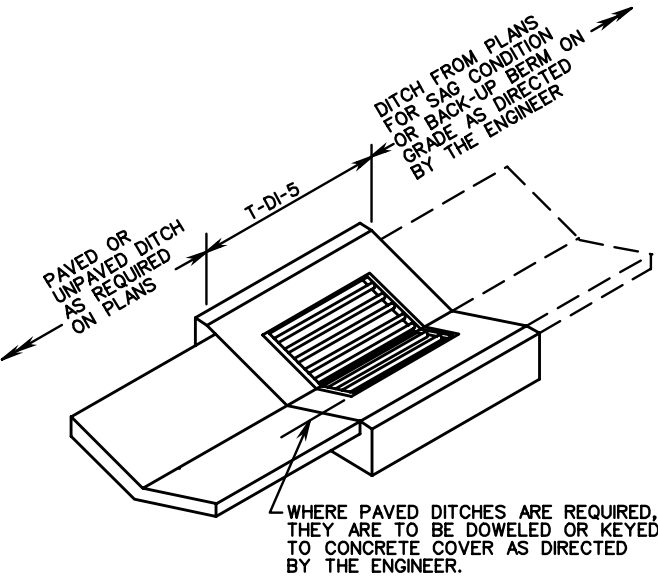

GRATE BAR SPACING CHART		
GRATE TYPE	MAXIMUM DIMENSION	
	a	b
A I	1 1/2"	3"
A III	1"	1"

ST'D PG-2 TYPE	COVER DIMENSIONS AND QUANTITIES								
	W1	W2	W3	W4	D*	D1	D2	X	Z
A1,A2,A3	3'-0 1/2"	2'-0 1/16"	2'-0 5/16"	1'-0 3/8"	6"	4"	3"	14"	2'-2"
B1,B2,B3,B4, C1,C2,C3	2'-9"	2'-9"	1'-6 7/16"	1'-6 1/16"	8"	4 1/2"	4 1/2"	16"	2'-8"
E	2'-3"	2'-3"	1'-8 1/16"	1'-8 1/16"	12"	9"	9"	19"	2'-8"

NOTES:

1. SEE GENERAL NOTES-PRECAST FOR ADDITIONAL DETAILS.
2. CONCRETE SHALL BE 4000 PSI MINIMUM.
3. REINFORCING STEEL SHALL BE IN ACCORDANCE WITH ASTM-A 615.
4. CONCRETE COVER AND GRATE ARE TO BE FURNISHED AS A SINGLE UNIT.
5. DIMENSIONS SHOWN ARE MINIMUM. ACTUAL DIMENSIONS MAY VARY WITH MANUFACTURER.
6. GRATE BARS ARE TO BE INSTALLED SO THEY WILL BE ALIGNED PARALLEL TO THE DITCH FLOW.
7. WHERE DITCH SLOPES DO NOT MATCH THOSE OF INLET COVER, THE AREA ADJACENT TO THE INLET IS TO BE GRADED TO PROVIDE A SMOOTH TRANSITION.
8. DI-5 IS TO BE UTILIZED IN LOCATIONS NOT NORMALLY SUBJECT TO TRAFFIC.

STANDARD PRECAST TOP UNITS

VIRGINIA DEPARTMENT OF TRANSPORTATION