

SURVEYED BY \_\_\_\_\_  
 SUPERVISED BY \_\_\_\_\_  
 DESIGNED BY \_\_\_\_\_

DESIGN FEATURES RELATING TO CONSTRUCTION OR TO REGULATION AND CONTROL OF TRAFFIC MAY BE SUBJECT TO CHANGE AS DEEMED NECESSARY BY THE DEPARTMENT

REVISION	DATE	FEDERAL AID PROJECT		STATE PROJECT		SHEET
	11					

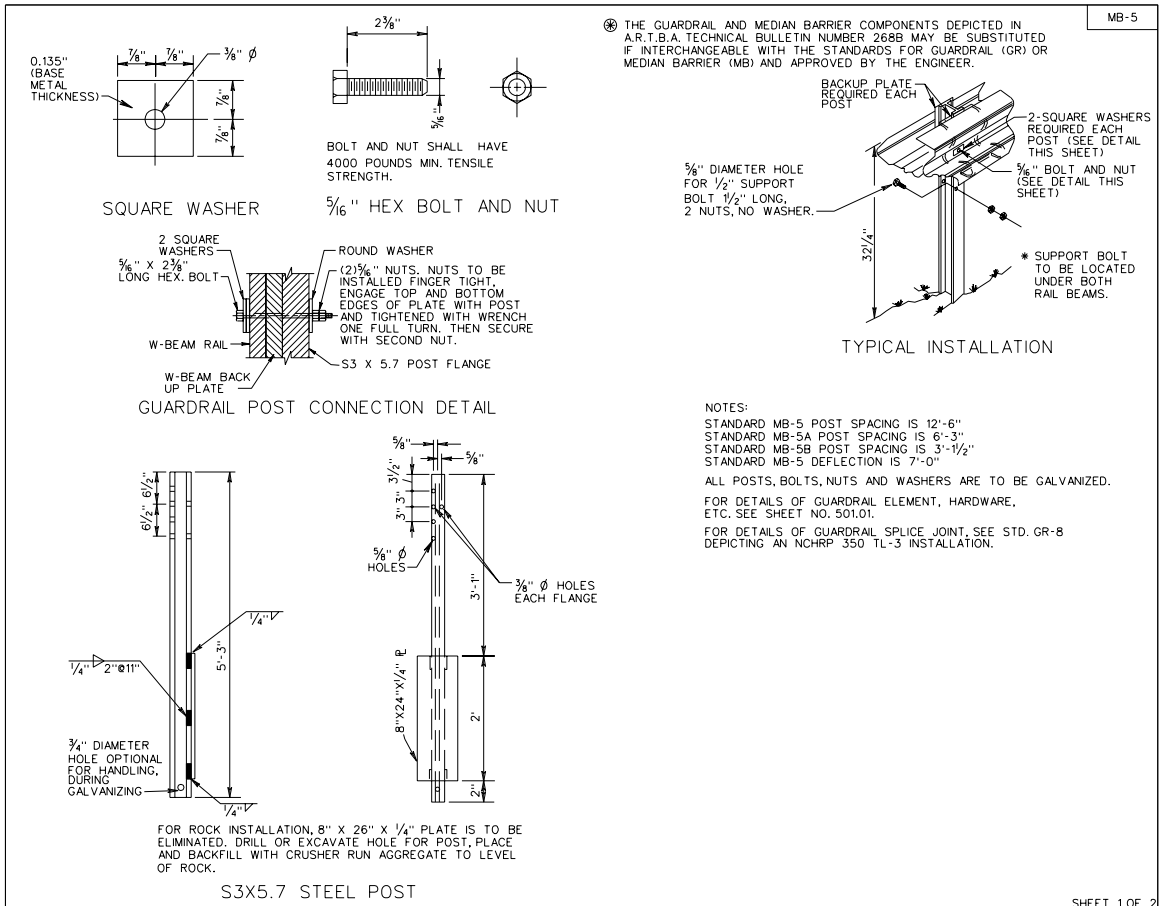

SPECIFICATION REFERENCE	STANDARD W BEAM MEDIAN BARRIER (WEAK POST SYSTEM) TL-3 (>45 MPH)	SHEET 1 OF 2
221 505	VIRGINIA DEPARTMENT OF TRANSPORTATION	REV. 7/05 501.42

REV. 7/05  
 SPECIAL DESIGN SECTION  
 DRAWING NO. A-95

FLANK	PROJECT	REVISION	SHEET