

APPENDIX D METRIC

QUANTITY TABLES

	Page
TABLE D 1M STONE FOR EROSION CONTROL WITH ST'D. ES-1 END SECTIONS	D-1
TABLE D-2M STONE FOR EROSION CONTROL WITH ST'D. ES-2 END SECTIONS	D-1
TABLE D-3M STONE FOR EROSION CONTROL WITH ST'D. ES-3 END SECTIONS	D-2
TABLE D-4M STONE FOR EROSION CONTROL WITH ST'D. EW-1 AND EW-6 ENDWALLS	D-2
TABLE D-5M STONE FOR EROSION CONTROL WITH ST'D. EW-1A ENDWALLS	D-3
TABLE D-6M STONE FOR EROSION CONTROL WITH ST'D. EW-2 AND EW-7 ENDWALLS	D-3
TABLE D-7M STONE FOR EROSION CONTROL WITH ST'D. EW-2S AND EW-7S ENDWALLS (30 DEGREE SKEW)	D-4
TABLE D-7A M STONE FOR EROSION CONTROL WITH ST'D. EW-2S AND EW-7S ENDWALLS (45 DEGREE SKEW)	D-4
TABLE D-8M STONE FOR EROSION CONTROL WITH ST'D. EW-2A ENDWALLS	D-5
TABLE D-9M STONE FOR EROSION CONTROL WITH ST'D. EW-9 AND EW-10 PIPE ARCHES	D-5
TABLE D-10M STONE FOR EROSION CONTROL FOR BOX CULVERT 6ST'D. BS00.6 THRU BS15.0 (NO SKEW)	D-6
TABLE D-11M STONE FOR EROSION CONTROL FOR BOX CULVERT ST'D. BS00.6 THRU BS15.0 (15 DEGREE SKEW)	D-7
TABLE D-12M STONE FOR EROSION CONTROL FOR BOX CULVERT ST'D. BS00.6 THRU BS15.0 (30 DEGREE SKEW)	D-8
TABLE D-13M STONE FOR EROSION CONTROL FOR BOX CULVERT ST'D. BS00.6 THRU BS15.0 (45 DEGREE SKEW)	D-9
TABLE D-14M STONE FOR EROSION CONTROL FOR MULTIPLE BOX CULVERTS (INCREMENTS FOR EACH ADDITIONAL BARREL)	D-10
FIGURE D-1M COMPUTATIONS FOR STANDARD JB-1 JUNCTION BOX	D-11
TABLE D-15M ADJUSTMENT QUANTITIES FOR JUNCTION BOX	D-11
TABLE D-16M COMPUTATION OF RATIOS FOR MINOR STRUCTURE EXCAVATION STANDARD EW-1A	D-12

	PAGE
TABLE D-17M COMPUTATION OF RATIOS FOR MINOR STRUCTURE EXCAVATION STANDARDS EW-2, EW-2A.....	D-13
TABLE D-18M COMPUTATION OF RATIOS FOR MINOR STRUCTURE EXCAVATION STANDARD EW-2S (30 DEGREES)	D-14
TABLE D-19M COMPUTATION OF RATIOS FOR MINOR STRUCTURE EXCAVATION STANDARD EW-2S (45 DEGREES)	D-15
TABLE D-20M COMPUTATION OF RATIOS FOR MINOR STRUCTURE EXCAVATION STANDARD EW-6.....	D-16
TABLE D-21M COMPUTATION OF RATIOS FOR MINOR STRUCTURE EXCAVATION STANDARD EW-6 (30 DEGREE)	D-17
TABLE D-22M COMPUTATION OF RATIOS FOR MINOR STRUCTURE EXCAVATION STANDARD EW-6S (45 DEGREE)	D-18
TABLE D-23M COMPUTATION OF RATIOS FOR MINOR STRUCTURE EXCAVATION STANDARD EW-7S	D-19
TABLE D-24M COMPUTATION OF RATIOS FOR MINOR STRUCTURE EXCAVATION STANDARD EW-7S (30 DEGREE)	D-20
TABLE D-25M COMPUTATION OF RATIOS FOR MINOR STRUCTURE EXCAVATION STANDARD EW-7S (45 DEGREE)	D-21
TABLE D-26M COMPUTATION OF RATIOS FOR MINOR STRUCTURE EXCAVATION STANDARD EW-9	D-22
TABLE D-27M COMPUTATION OF RATIOS FOR MINOR STRUCTURE EXCAVATION STANDARD EW-10	D-23
TABLE D-28M COMPUTATION OF RATIOS FOR MINOR STRUCTURE EXCAVATION STANDARD EW-11.....	D-24
TABLE D-29M COMPUTATION OF RATIOS FOR MINOR STRUCTURE EXCAVATION STANDARD ES-1	D-25
TABLE D-30M COMPUTATION OF RATIOS FOR MINOR STRUCTURE EXCAVATION STANDARD ES-2	D-26
TABLE D-31M COMPUTATION OF RATIOS FOR MINOR STRUCTURE EXCAVATION STANDARD ES-3	D-27
FIGURE D-2M SUBBASE END AREAS AT CURB AND GUTTER LOCATION	D-28
TABLE D-32M AREAS FOR ENTRANCE GUTTER STANDARD CG-9D	D-29
FIGURE D-4M EARTHWORK QUANTITY COMPUTATIONS	D-30

CULVERT SIZE DIAMETER (mm)	1 ½ : 1 Slope		2:1 Slope	
	Normal Depth (0.6m)	Increments For Each Add'l. 0.3 m Above Normal	Normal Depth (0.6m)	Increments For Each Add'l. 0.3 m Above Normal
	Cu. Meters	Cu. Meters	Cu. Meters	Cu. Meters
300	0.77	0.39	0.73	0.36
375	1.22	0.61	1.14	0.57
450	1.76	0.88	1.65	0.83
600	3.11	1.56	2.92	1.46
750	4.87	2.43	4.58	2.29
900	7.01	3.50	6.59	3.29
1050	9.41	4.70	8.83	4.42
1200	12.10	6.05	11.36	5.68
1350	15.21	7.61	14.27	7.13
1500	18.86	9.34	17.51	8.76

TABLE D-1M STONE FOR EROSION CONTROL WITH ST'D. ES-1 END SECTIONS

CULVERT SIZE DIAMETER (mm)	1 ½ : 1 Slope		2:1 Slope	
	Normal Depth (0.6m)	Increments For Each Add'l. 0.3 m Above Normal	Normal Depth (0.6m)	Increments For Each Add'l. 0.3 m Above Normal
	Cu. Meters	Cu. Meters	Cu. Meters	Cu. Meters
300	0.87	0.44	0.82	0.41
375	1.28	0.64	1.21	0.60
450	1.95	0.97	1.84	0.92
600	3.44	1.72	3.24	1.62
750	5.35	2.67	5.04	2.52
900	7.68	3.84	7.25	3.62
1050	10.44	5.22	9.84	4.92
1200	13.42	6.71	12.65	6.32
1350	16.92	8.46	15.94	7.97
1500	20.80	10.40	19.58	9.79

TABLE D-2M

STONE FOR EROSION CONTROL WITH ST'D. ES-2 END SECTIONS

Quantities To Be Used Only For Computations of Dry Rip Rap For Outlet Protection.*

PIPE ARCH SPAN RISE (mm)	1 ½ : 1 Slope		2:1 Slope	
	Normal Depth (0.6m)	Increments For Each Add'l. 0.3 m Above Normal	Normal Depth (0.6m)	Increments For Each Add'l. 0.3 m Above Normal
	Cu. Meters	Cu. Meters	Cu. Meters	Cu. Meters
450 340	1.48	0.72	1.35	0.68
510 380	1.87	0.93	1.75	0.87
560 420	2.30	1.15	2.15	1.07
680 500	3.29	1.65	3.08	1.54
800 580	4.59	2.30	4.29	2.15
910 660	6.11	3.06	5.72	2.86
1030 740	7.75	3.87	7.25	3.63
1150 820	9.60	4.80	8.99	4.50
1390 970	13.70	6.85	12.81	6.40
1630 1120	18.52	9.26	17.31	8.65

TABLE D-3M

STONE FOR EROSION CONTROL WITH ST'D. ES-3 END SECTIONS

CULVERT SIZE DIAMETER (mm)	1 ½ : 1 Slope		2:1 Slope		Increments For Each Add'l. Pipe (St'd. EW-6)	
	Normal Depth (0.6m)	Increments For Each Add'l. 0.3 m Above Normal	Normal Depth (0.6m)	Increments For Each Add'l. 0.3 m Above Normal	Conc.	C.M.
	Cu. Meters	Cu. Meters	Cu. Meters	Cu. Meters	Cu Yds	Cu Yds.
300	0.53	0.26	0.50	0.25	0.26	0.22
375	0.83	0.41	0.79	0.39	0.40	0.35
450	1.20	0.60	1.14	0.57	0.58	0.51
600	2.13	1.07	2.02	1.01	1.01	0.90
750	3.34	1.67	3.17	1.59	1.60	1.41
900	4.84	2.42	4.60	2.30	2.34	2.07

TABLE D-4M

STONE FOR EROSION CONTROL WITH ST'D. EW-1 AND EW-6 ENDWALLS

Quantities To Be Used Only For Computations of Dry Rip Rap For Outlet Protection.*

* Rev. 7/10

ELLIPTICAL PIPE SPAN RISE (mm)	1 ½ : 1 Slope		2:1 Slope	
	Normal Depth (0.6m)	Increments For Each Add'l. 0.3 m Above Normal	Normal Depth (0.6m)	Increments For Each Add'l. 0.3 m Above Normal
	Cu. Meters	Cu. Meters	Cu. Meters	Cu. Meters
575 365	1.23	0.62	1.17	0.59
770 490	2.24	1.12	2.13	1.06
865 550	2.82	1.41	2.68	1.34
960 610	3.47	1.73	3.29	1.65
1055 670	4.20	2.10	3.99	2.00
1150 730	4.99	2.49	4.73	2.37
1250 795	5.92	2.96	5.62	2.81
1345 855	6.84	3.42	6.50	3.25

TABLE D-5M

STONE FOR EROSION CONTROL WITH ST'D. EW-1A ENDWALLS

CULVERT SIZE DIAMETER (mm)	1 ½ : 1 Slope		2:1 Slope		ST'D. EW-7
	Normal Depth (0.6m)	Increments For Each Add'l. 0.3 m Above Normal	Normal Depth (0.6m)	Increments For Each Add'l. 0.3 m Above Normal	Increments For Each Add'l. Pipe (Conc.)
	Cu. Meters	Cu. Meters	Cu. Meters	Cu. Meters	Cu. Meters
1050	8.02	4.01	7.48	3.74	3.49
1200	10.65	5.32	9.92	4.96	4.57
1350	13.44	6.72	12.52	6.26	5.75
1500	16.55	8.28	15.42	7.71	7.09
1650	19.99	9.99	18.62	9.31	8.57
1800	23.75	11.87	22.11	11.06	10.16
1950	28.13	14.07	26.19	13.10	11.94
2100	32.56	16.28	30.31	15.16	13.84

TABLE D-6M

STONE FOR EROSION CONTROL WITH ST'D. EW-2 AND EW-7 ENDWALLS

Quantities To Be Used Only For Computations of Dry Rip Rap For Outlet Protection.*

* Rev. 7/10

CULVERT SIZE DIAMETER (mm)	1 ½ : 1 Slope		2:1 Slope		ST'D. EW-7S
	Normal Depth (0.6m)	Increments For Each Add'l. 0.3 m Above Normal	Normal Depth (0.6m)	Increments For Each Add'l. 0.3 m Above Normal	Increments For Each Add'l. Pipe (Conc.)
	Cu. Meters	Cu. Meters	Cu. Meters	Cu. Meters	Cu. Meters
1050	8.34	4.17	7.80	3.90	4.03
1200	11.04	5.52	10.31	5.16	5.27
1350	13.96	6.98	13.03	6.52	6.64
1500	17.21	8.60	16.07	8.04	8.18
1650	20.77	10.38	19.40	9.70	9.90
1800	24.70	12.35	23.06	11.53	11.74
1950	29.24	14.62	27.30	13.65	13.79
2100	33.83	16.91	31.58	15.79	15.97

TABLE D-7M

**STONE FOR EROSION CONTROL WITH ST'D. EW-2S AND EW-7S ENDWALLS
(30 DEGREE SKEW)**

CULVERT SIZE DIAMETER (mm)	1 ½ : 1 Slope		2:1 Slope		ST'D. EW-7S
	Normal Depth (0.6m)	Increments For Each Add'l. 0.3 m Above Normal	Normal Depth (0.6m)	Increments For Each Add'l. 0.3 m Above Normal	Increments For Each Add'l. Pipe (Conc.)
	Cu. Meters	Cu. Meters	Cu. Meters	Cu. Meters	Cu. Meters
1050	9.68	4.84	9.34	4.67	4.94
1200	12.81	6.41	12.35	6.18	6.46
1350	16.18	8.09	15.60	7.80	8.13
1500	19.92	9.96	19.20	9.60	10.03
1650	24.07	12.03	23.20	11.60	12.12
1800	28.58	14.29	27.54	13.77	14.37
1950	33.81	16.90	32.57	16.28	16.89
2100	39.12	19.56	37.69	18.84	19.57

TABLE D-7A M

**STONE FOR EROSION CONTROL WITH ST'D. EW-2S AND EW-7S ENDWALLS
(45 DEGREE SKEW)**

Quantities To Be Used Only For Computations of Dry Rip Rap For Outlet Protection.*

* Rev. 7/10

ELLIPTICAL PIPE SPAN RISE (mm)	1 ½ : 1 Slope		2:1 Slope	
	Normal Depth (0.6m)	Increments For Each Add'l. 0.3 m Above Normal	Normal Depth (0.6m)	Increments For Each Add'l. 0.3 m Above Normal
	Cu. Meters	Cu. Meters	Cu. Meters	Cu. Meters
1535 975	10.72	5.36	9.54	4.77
1730 1095	14.08	7.04	12.62	6.31
1920 1220	17.68	8.84	15.81	7.90
2110 1340	21.05	10.53	18.81	9.40
2305 1465	25.39	12.70	22.67	11.33
2495 1585	31.72	15.86	28.58	14.29
2609 1705	34.47	17.23	30.75	15.37

TABLE D-8M
STONE FOR EROSION CONTROL WITH ST'D. EW-2A ENDWALLS

PIPE ARCH Span Riser (mm)	1 ½ : 1 Slope		2:1 Slope		ST'D. EW-10
	Normal Depth (0.6m)	Increments For Each Add'l. 0.3 m Above Normal	Normal Depth (0.6m)	Increments For Each Add'l. 0.3 m Above Normal	Increments For Each Add'l. Pipe
	Cu. Meters	Cu. Meters	Cu. Meters	Cu. Meters	Cu. Meters
425 325	0.82	0.41	0.77	0.39	0.39
525 375	1.17	0.58	1.11	0.55	0.52
600 450	1.60	0.80	1.52	0.76	0.68
700 500	2.08	1.04	1.98	0.99	0.84
875 600	3.11	1.55	2.95	1.47	1.16
1050 725	4.52	2.26	4.29	2.14	1.72
1225 825	6.02	3.01	5.72	2.86	2.29
1425 950	8.11	4.05	7.70	3.85	3.12

TABLE D-9M
STONE FOR EROSION CONTROL WITH ST'D. EW-9 AND EW-10 PIPE ARCHES
Quantities To Be Used Only For Computations of Dry Rip Rap For Outlet Protection.*

* Rev. 7/10

CULVERT SIZE (Meters) SPAN X RISE	1 ½ : 1 Slope		2:1 Slope	
	Normal Depth (0.6m)	Increments For Each Add'l. 0.3 m Above Normal	Normal Depth (0.6m)	Increments For Each Add'l. 0.3 m Above Normal
	Cu. Meters	Cu. Meters	Cu. Meters	Cu. Meters
0.91 x 0.91	7.12	3.56	6.92	3.46
0.91 x 1.22	9.82	4.91	9.82	4.91
1.22 x 0.91	9.71	4.86	9.10	4.55
1.22 x 1.22	12.82	6.41	12.51	6.25
1.22 x 1.52	16.29	8.15	16.28	8.14
1.22 x 1.83	20.03	10.01	20.64	10.32
1.52 x 0.91	12.60	6.30	11.54	5.77
1.52 x 1.22	16.09	8.04	15.22	7.61
1.52 x 1.52	19.93	9.96	19.34	9.67
1.52 x 1.83	24.14	12.07	24.07	12.04
1.52 x 2.13	28.80	14.40	29.13	14.57
1.83 x 1.22	19.85	9.93	18.42	9.21
1.83 x 1.52	24.07	12.04	22.85	11.42
1.83 x 1.83	28.77	14.39	27.96	13.98
1.83 x 2.13	33.81	16.91	33.38	16.69
1.83 x 2.44	39.11	19.55	39.45	19.72
2.13 x 1.22	23.87	11.93	21.87	10.94
2.13 x 1.83	33.68	16.84	32.04	16.02
2.13 x 2.44	45.10	22.55	44.25	22.12
2.13 x 3.05	57.41	28.17	57.77	28.89
2.44 x 1.22	28.41	14.20	25.77	12.89
2.44 x 1.83	39.08	19.54	36.60	18.30
2.44 x 2.44	51.27	25.64	49.78	24.89
2.44 x 3.05	64.56	32.28	64.38	32.19
2.74 x 1.22	33.17	16.59	29.87	14.93
2.74 x 1.83	44.78	22.39	41.40	20.70
2.74 x 2.44	57.63	28.81	55.14	27.57
2.74 x 3.05	71.85	35.92	70.55	35.28
2.74 x 3.66	87.57	43.79	87.99	43.99
3.05 x 1.22	38.48	19.24	34.44	17.22
3.05 x 1.83	51.06	25.53	46.71	23.36
3.05 x 2.44	64.58	32.29	61.01	30.51
3.05 x 3.05	79.99	40.00	77.55	38.78
3.05 x 3.66	96.84	48.42	95.99	47.99
3.66 x 1.83	64.12	32.06	57.80	28.90
3.66 x 2.44	79.60	39.80	73.68	36.84
3.66 x 3.05	96.58	48.29	91.69	45.85
3.66 x 3.66	115.36	57.68	111.82	55.91

**TABLE D-10M - STONE FOR EROSION CONTROL FOR BOX CULVERT
ST'D. BS00.6 THRU BS15.0 (NO SKEW)**

Quantities To Be Used Only For Computations of Dry Rip Rap For Outlet Protection.*

* Rev. 7/10

CULVERT SIZE (Meters) SPAN X RISE	1 ½ : 1 Slope		2:1 Slope	
	Normal Depth (0.6m)	Increments For Each Add'l. 0.3 m Above Normal	Normal Depth (0.6m)	Increments For Each Add'l. 0.3 m Above Normal
	Cu. Meters	Cu. Meters	Cu. Meters	Cu. Meters
0.91 x 0.91	7.17	3.58	6.97	3.48
0.91 x 1.22	9.89	4.95	9.89	4.94
1.22 x 0.91	9.78	4.89	9.17	4.58
1.22 x 1.22	12.91	6.46	12.60	6.30
1.22 x 1.52	16.41	8.21	16.39	8.20
1.22 x 1.83	20.17	10.09	20.78	10.39
1.52 x 0.91	12.69	6.34	11.62	5.81
1.52 x 1.22	16.20	8.10	15.34	7.67
1.52 x 1.52	20.08	10.04	19.49	9.75
1.52 x 1.83	24.31	12.16	24.25	12.13
1.52 x 2.13	29.01	14.51	29.34	14.67
1.83 x 1.22	19.99	10.00	18.56	9.28
1.83 x 1.52	24.25	12.12	23.02	11.51
1.83 x 1.83	28.98	14.49	28.17	14.08
1.83 x 2.13	34.06	17.03	33.63	16.81
1.83 x 2.44	39.39	19.69	39.73	19.86
2.13 x 1.22	24.03	12.02	22.04	11.02
2.13 x 1.83	33.92	16.96	32.29	16.14
2.13 x 2.44	45.43	22.71	44.58	22.29
2.13 x 3.05	57.83	28.91	58.18	29.09
2.44 x 1.22	28.60	14.30	25.96	12.98
2.44 x 1.83	39.37	19.68	36.88	18.44
2.44 x 2.44	51.65	25.83	50.16	25.08
2.44 x 3.05	65.03	32.52	64.86	32.43
2.74 x 1.22	33.38	16.69	30.08	15.04
2.74 x 1.83	45.10	22.55	41.72	20.86
2.74 x 2.44	58.05	29.03	55.56	27.78
2.74 x 3.05	72.38	36.19	71.08	35.54
2.74 x 3.66	88.21	44.10	88.62	44.31
3.05 x 1.22	38.72	19.36	34.68	17.34
3.05 x 1.83	51.41	25.71	47.07	23.53
3.05 x 2.44	65.05	32.53	61.49	30.74
3.05 x 3.05	80.58	40.29	78.14	39.07
3.05 x 3.66	97.55	48.77	96.70	48.35
3.66 x 1.83	64.54	32.27	58.23	29.11
3.66 x 2.44	80.16	40.08	74.24	37.12
3.66 x 3.05	97.29	48.64	92.40	46.20
3.66 x 3.66	116.21	58.11	112.67	56.33

TABLE D-11M - STONE FOR EROSION CONTROL FOR BOX CULVERT

ST'D. BS00.6 THRU BS15.0 (15 DEGREE SKEW)

Quantities To Be Used Only For Computations of Dry Rip Rap For Outlet Protection.*

* Rev. 7/10

CULVERT SIZE (Meters) SPAN X RISE	1 ½ : 1 Slope		2:1 Slope	
	Normal Depth (0.6m)	Increments For Each Add'l. 0.3 m Above Normal	Normal Depth (0.6m)	Increments For Each Add'l. 0.3 m Above Normal
	Cu. Meters	Cu. Meters	Cu. Meters	Cu. Meters
0.91 x 0.91	7.40	3.70	7.24	3.62
0.91 x 1.22	10.28	5.14	10.39	5.20
1.22 x 0.91	10.00	5.00	9.41	4.70
1.22 x 1.22	13.35	6.68	13.10	6.55
1.22 x 1.52	17.08	8.54	17.27	8.63
1.22 x 1.83	21.31	10.66	22.15	11.08
1.52 x 0.91	12.89	6.45	11.83	5.92
1.52 x 1.22	16.60	8.30	15.79	7.89
1.52 x 1.52	20.72	10.36	20.29	10.14
1.52 x 1.83	25.39	12.69	25.52	12.76
1.52 x 2.13	30.41	15.21	31.10	15.55
1.83 x 1.22	20.40	10.20	18.97	9.49
1.83 x 1.52	24.87	12.44	23.74	11.87
1.83 x 1.83	29.99	14.99	29.34	14.67
1.83 x 2.13	35.42	17.71	35.28	17.64
1.83 x 2.44	41.30	20.65	42.04	21.02
2.13 x 1.22	24.45	12.23	22.41	11.21
2.13 x 1.83	34.83	17.42	33.36	16.68
2.13 x 2.44	47.11	23.56	46.77	23.38
2.13 x 3.05	60.92	30.46	62.13	31.06
2.44 x 1.22	29.02	14.51	26.31	13.15
2.44 x 1.83	40.24	20.12	37.85	18.92
2.44 x 2.44	53.40	26.70	52.28	26.14
2.44 x 3.05	68.22	34.11	68.72	34.36
2.74 x 1.22	33.82	16.91	30.40	15.20
2.74 x 1.83	45.93	22.96	42.61	21.31
2.74 x 2.44	59.72	29.86	57.54	28.77
2.74 x 3.05	75.41	37.71	74.73	37.37
2.74 x 3.66	92.78	46.39	94.24	47.12
3.05 x 1.22	39.16	19.58	34.96	17.48
3.05 x 1.83	52.19	26.10	47.88	23.94
3.05 x 2.44	66.65	33.32	63.36	31.68
3.05 x 3.05	83.47	41.73	81.65	40.83
3.05 x 3.66	101.95	50.98	102.18	51.09
3.66 x 1.83	65.13	32.56	58.80	29.40
3.66 x 2.44	81.60	40.80	75.80	37.90
3.66 x 3.05	99.86	49.93	95.46	47.73
3.66 x 3.66	120.29	60.15	117.72	58.86

**TABLE D-12M - STONE FOR EROSION CONTROL FOR BOX CULVERT
ST'D. BS00.6 THRU BS15.0 (30 DEGREE SKEW)**

Quantities To Be Used Only For Computations of Dry Rip Rap For Outlet Protection.*

* Rev. 7/10

CULVERT SIZE (Meters) SPAN X RISE	1 ½ : 1 Slope		2:1 Slope	
	Normal Depth (0.6m)	Increments For Each Add'l. 0.3 m Above Normal	Normal Depth (0.6m)	Increments For Each Add'l. 0.3 m Above Normal
	Cu. Meters	Cu. Meters	Cu. Meters	Cu. Meters
0.91 x 0.91	7.79	3.89	7.62	3.81
0.91 x 1.22	10.80	5.40	10.91	5.46
1.22 x 0.91	10.52	5.26	9.93	4.96
1.22 x 1.22	14.05	7.02	13.80	6.90
1.22 x 1.52	17.73	8.87	18.13	9.07
1.22 x 1.83	22.36	11.18	23.19	11.60
1.52 x 0.91	13.54	6.77	12.48	6.24
1.52 x 1.22	17.54	8.74	16.66	8.33
1.52 x 1.52	21.80	10.90	21.37	10.68
1.52 x 1.83	26.69	13.34	26.82	13.41
1.52 x 2.13	31.93	15.96	32.61	16.30
1.83 x 1.22	21.44	10.72	20.01	10.01
1.83 x 1.52	26.17	13.09	25.04	12.52
1.83 x 1.83	31.55	15.78	30.90	15.45
1.83 x 2.13	37.24	18.62	37.10	18.55
1.83 x 2.44	43.38	21.69	44.13	22.07
2.13 x 1.22	25.66	12.83	23.63	11.81
2.13 x 1.83	36.65	18.33	35.18	17.59
2.13 x 2.44	49.54	24.77	49.20	24.60
2.13 x 3.05	63.95	31.98	65.16	32.58
2.44 x 1.22	30.41	15.21	27.70	13.85
2.44 x 1.83	42.33	21.16	39.94	19.97
2.44 x 2.44	56.18	28.09	55.06	27.53
2.44 x 3.05	71.70	35.85	72.20	36.10
2.74 x 1.22	35.38	17.69	31.96	15.98
2.74 x 1.83	48.27	24.14	44.96	22.48
2.74 x 2.44	62.95	31.42	60.66	30.33
2.74 x 3.05	79.32	39.66	78.64	39.32
2.74 x 3.66	97.46	48.73	98.92	49.46
3.05 x 1.22	40.90	20.45	36.70	18.35
3.05 x 1.83	54.80	27.40	50.49	25.24
3.05 x 2.44	70.12	35.06	66.84	33.42
3.05 x 3.05	87.81	43.91	86.00	43.00
3.05 x 3.66	107.17	53.58	107.40	53.70
3.66 x 1.83	68.26	34.13	61.93	30.96
3.66 x 2.44	85.77	42.89	79.97	39.99
3.66 x 3.05	105.07	52.54	100.67	50.34
3.66 x 3.66	126.55	63.27	123.98	61.99

**TABLE D-13M - STONE FOR EROSION CONTROL FOR BOX CULVERT
ST'D. BS00.6 THRU BS15.0 (45 DEGREE SKEW)**

Quantities To Be Used Only For Computations of Dry Rip Rap For Outlet Protection.*

* Rev. 7/10

CULVERT SIZE (Meters) SPAN X RISE	1 ½ : 1 Slope		2:1 Slope	
	No Skew	15 Skew	30 Skew	45 Skew
	Cu. Meters	Cu. Meters	Cu. Meters	Cu. Meters
0.91 x 0.91	1.90	1.97	2.21	2.69
0.91 x 1.22	2.65	2.74	3.08	3.71
1.22 x 0.91	2.33	2.41	2.69	3.29
1.22 x 1.22	3.12	3.23	3.50	4.41
1.22 x 1.52	3.89	4.03	4.48	5.71
1.22 x 1.83	4.69	4.84	5.40	6.62
1.52 x 0.91	2.82	2.92	3.26	3.98
1.52 x 1.22	3.78	3.91	4.37	5.34
1.52 x 1.52	4.71	4.87	5.43	6.65
1.52 x 1.83	5.67	5.87	6.54	8.01
1.52 x 2.13	6.60	6.83	7.62	9.32
1.83 x 1.22	4.46	4.62	5.15	6.31
1.83 x 1.52	5.61	5.81	6.49	17.93
1.83 x 1.83	6.86	7.10	7.90	9.64
1.83 x 2.13	8.08	8.35	9.36	11.38
1.83 x 2.44	8.91	9.23	10.30	12.61
2.13 x 1.22	5.12	5.30	5.91	7.24
2.13 x 1.83	7.77	8.03	8.96	10.95
2.13 x 2.44	10.55	10.92	12.22	14.87
2.13 x 3.05	13.37	13.82	15.49	18.81
2.44 x 1.22	5.80	6.00	6.69	8.20
2.44 x 1.83	8.70	9.00	10.04	12.29
2.44 x 2.44	11.60	12.01	13.39	16.40
2.44 x 3.05	14.50	15.01	16.74	20.50
2.74 x 1.22	6.46	6.69	7.45	9.13
2.74 x 1.83	9.69	10.03	11.19	13.70
2.74 x 2.44	12.91	13.37	15.03	18.38
2.74 x 3.05	16.53	17.10	19.13	23.31
2.74 x 3.66	20.00	20.69	23.15	28.18
3.05 x 1.22	7.14	7.39	8.24	10.09
3.05 x 1.83	10.71	11.09	12.37	15.14
3.05 x 2.44	14.28	14.78	16.48	20.19
3.05 x 3.05	17.85	18.48	20.60	25.24
3.05 x 3.66	21.41	22.16	24.73	30.28
3.66 x 1.83	12.72	13.17	14.68	17.98
3.66 x 2.44	16.95	17.55	19.58	23.98
3.66 x 3.05	21.19	21.94	24.47	29.97
3.66 x 3.66	25.43	26.33	29.36	35.96

TABLE D-14M - STONE FOR EROSION CONTROL FOR MULTIPLE BOX CULVERTS (INCREMENTS FOR EACH ADDITIONAL BARREL)

Quantities To Be Used Only For Computations of Dry Rip Rap For Outlet Protection.*

* Rev. 7/10

PROJECT _____ STATION _____

1. Grade Elevation _____
 2. Minus Inv. Elev. _____
 3. Vertical Difference _____
 4. Minus Pipe Size (m) _____
 5. Difference _____

If Line 5 is over 1.62 m, use Type A Tower
 If Line 5 is 0.96 m to 1.62 m, use Type B Tower
 If Line 5 is 0.71 m to 0.96 m, use Type C Tower

Increase above dimensions by 0.30 m for use with 1800 mm pipe.

CHAMBER

6. Type _____ Pipe Size _____ Turn Angle _____

REINFORCING STEEL Kg

CONCRETE CU. METERS

Less: Pipe Openings

7. Size _____ Class _____ Defl. Angle _____

8. Size _____ Class _____ Defl. Angle _____

9. Size _____ Class _____ Defl. Angle _____

10. Size _____ Class _____ Defl. Angle _____

11. Total Deductions (Lines 7-10) _____

12. Quantities for Chamber (Subtract Line 11 from Line 6 and Transfer to Line 17)

TOWER

13. Type _____ x Height _____

x 1200 mm Pipe • Line 3 minus 1.93 m Min. Height
 x 1350 mm Pipe • Line 3 minus 2.08 m
 x 1500 mm Pipe • Line 3 minus 2.23 m Type A • 0.91 m
 x 1650 mm Pipe • Line 3 minus 2.39 m Type B • 0.23 m
 x 1800 mm Pipe • Line 3 minus 2.84 m Type C • 0.0 m

14. Minimum Height Quantities

15. (Line 13 less Min. Height) x increment per meter

16. Quantities for tower (Add Lines 14 & 15)

17. Quantities for Chamber (Line 12)

18. Total Concrete and Reinforcing Steel (Add Lines 16 & 17)

See Standard JB-1

See Table D-27

STRUCTURAL STEEL QUANTITY (Kg)

DISPLACEMENT QUANTITIES FOR PIPE OPENINGS
 (To be used with standard JB-1 Junction Box)

PIPE SIZE	PIPE CLASS	CONCRETE				REINFORCING STEEL Kg
		0° CU. METERS	15° CU. METERS	30° CU. METERS	45° CU. METERS	
300 mm	III, IV, V C. M.	0.03 0.01	0.03 0.02	0.03 0.02	0.04 0.02	8.0 5.0
375 mm	III, IV, V C. M.	0.04 0.02	0.04 0.02	0.04 0.03	0.05 0.03	11.3 7.2
450 mm	III, IV, V C. M.	0.05 0.03	0.06 0.03	0.06 0.04	0.08 0.05	15.1 9.8
600 mm	III, IV, V C. M.	0.09 0.06	0.09 0.06	0.10 0.07	0.13 0.08	24.3 16.3
750 mm	III, IV, V C. M.	0.14 0.09	0.14 0.09	0.16 0.10	0.20 0.13	35.7 24.3
900 mm	III, IV, V C. M.	0.19 0.13	0.20 0.13	0.22 0.15	0.28 0.19	49.3 33.9
1050 mm	III, IV, V C. M.	0.26 0.18	0.27 0.18	0.30 0.20	0.37 0.25	65.0 45.2
1200 mm	III, IV, V C. M.	0.34 0.23	0.35 0.24	0.39 0.27	0.48 0.33	83.0 58.0
1350 mm	III & IV V C. M.	0.42 0.44 0.29	0.44 0.46 0.30	0.49 0.51 0.34	0.60 0.63 0.42	103.1 107.7 72.4
1500 mm	III & IV V C. M.	0.52 0.54 0.36	0.54 0.56 0.37	0.60 0.63 0.42	0.74 0.77 0.51	135.4 130.5 88.5
1650 mm	III & IV V C. M.	0.63 0.65 0.44	0.65 0.67 0.45	0.72 0.75 0.51	0.89 0.93 0.62	149.9 155.5 106.2
1800 mm	III & IV V C. M.	0.74 0.77 0.52	0.77 0.80 0.54	0.86 0.88 0.60	1.06 1.09 0.74	176.6 182.6 125.4

FIGURE D-1M
 COMPUTATIONS FOR STANDARD JB-1 JUNCTION BOX
 TABLE D-15M
 ADJUSTMENT QUANTITIES FOR JUNCTION BOX

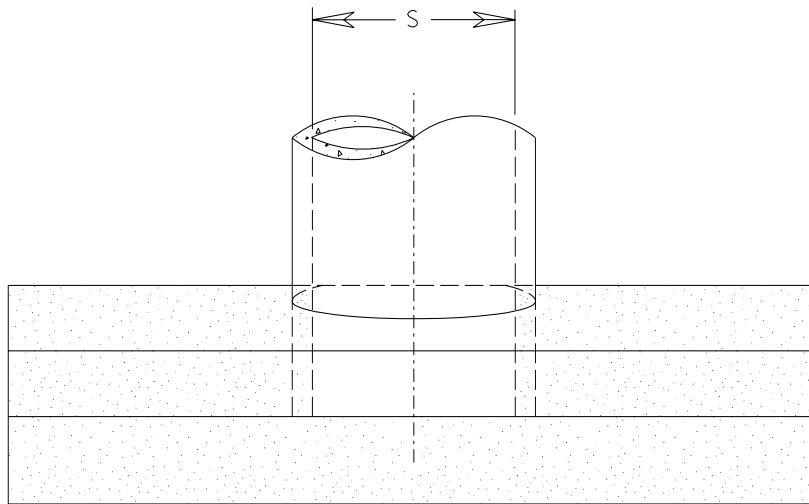

PLAN VIEW

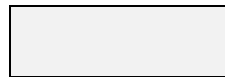

Area for computing ratio

STANDARD	(S) Span of Culvert (mm)	Area (A)
		Conc or C. M. Square Meters
EW-1A	1250	2.26
	1345	2.48

Area is given for one endwall.
Double area shown if two endwalls are used.

TO DETERMINE RATIO	$\frac{A}{S \text{ (meters)} \times \text{Length of Culvert}}$
-----------------------	--

TABLE D-16M
COMPUTATION OF RATIOS FOR MINOR STRUCTURE EXCAVATION
STANDARD EW-1A

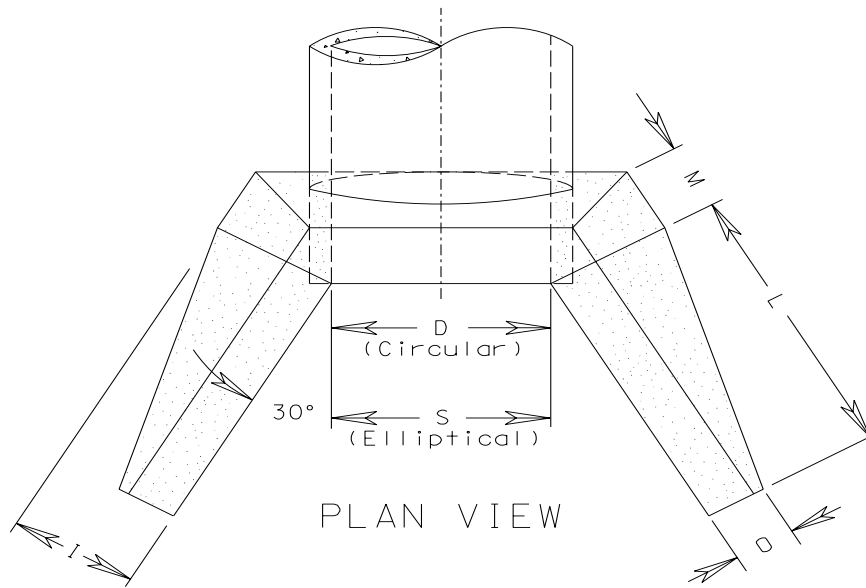

Area for computing ratio

(D) Diameter* of Culvert (mm)	Area (A)	
	1 ½ : 1 Slope	2 : 1 Slope
	Sq. Meters	Sq. Meters
1200	2.48	3.12
1350	3.06	3.83
1500	3.65	4.56
1650	4.35	5.42
1800	5.09	6.35
1950	5.86	7.39
2100	6.65	8.42

(S) Span* of Culvert (mm)	Area (A)	
	1 ½ : 1 Slope	2 : 1 Slope
	Sq. Meters	Sq. Meters
1535	2.15	2.64
1730	2.15	2.64
1920	2.48	3.12
2110	3.06	3.83
2305	3.65	4.56
2495	4.35	5.42
2690	5.09	6.35

Area is given for one endwall.
Double area shown if two endwalls are used.
*Nominal sizes are shown. See standard for
actual "D" and "S" dimensions .

TO DETERMINE RATIO	$\frac{A}{D \text{ or } S \text{ (meters)} \times \text{Length of Culvert}}$
-----------------------	--

TABLE D-17M
COMPUTATION OF RATIOS FOR MINOR STRUCTURE EXCAVATION
STANDARDS EW-2, EW-2A

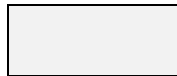
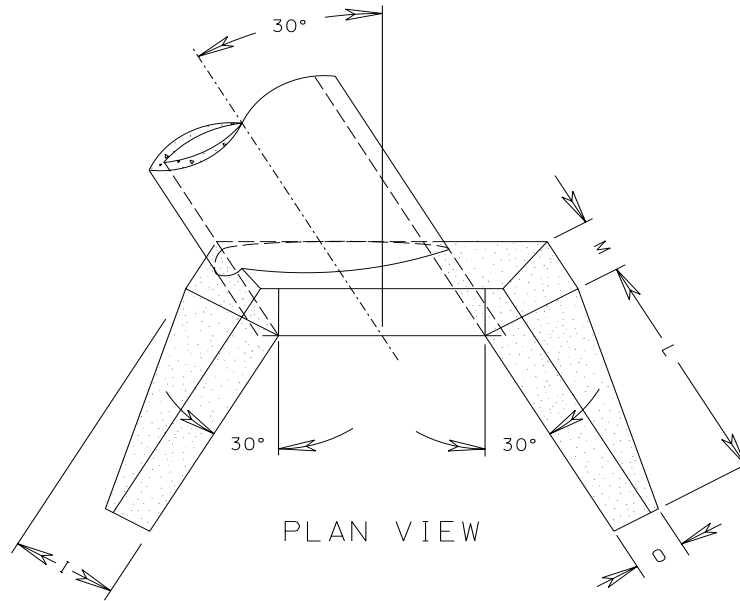

Area for computing ratio

(D) Diameter * Of Culvert (mm)	Area (A)	
	1 ½ : 1 Slope	2 : 1 Slope
	Sq. Meters	Sq.Meters
1200	2.49	3.12
1350	3.06	3.83
1500	3.66	4.57
1650	4.35	5.43
1800	5.10	6.36
1950	5.86	7.39
2100	6.66	8.43

Area is given for one endwall.
Double area shown if two endwalls are used.
*Nominal sizes are shown See St'd. EW-2.
For actual "D" dimension .

TO DETERMINE RATIO	$\frac{A}{D \text{ (meters)} \times \text{Length of Culvert}}$
-----------------------	--

TABLE D-18M
COMPUTATION OF RATIOS FOR MINOR STRUCTURE EXCAVATION
STANDARD EW-2S (30 DEGREES)

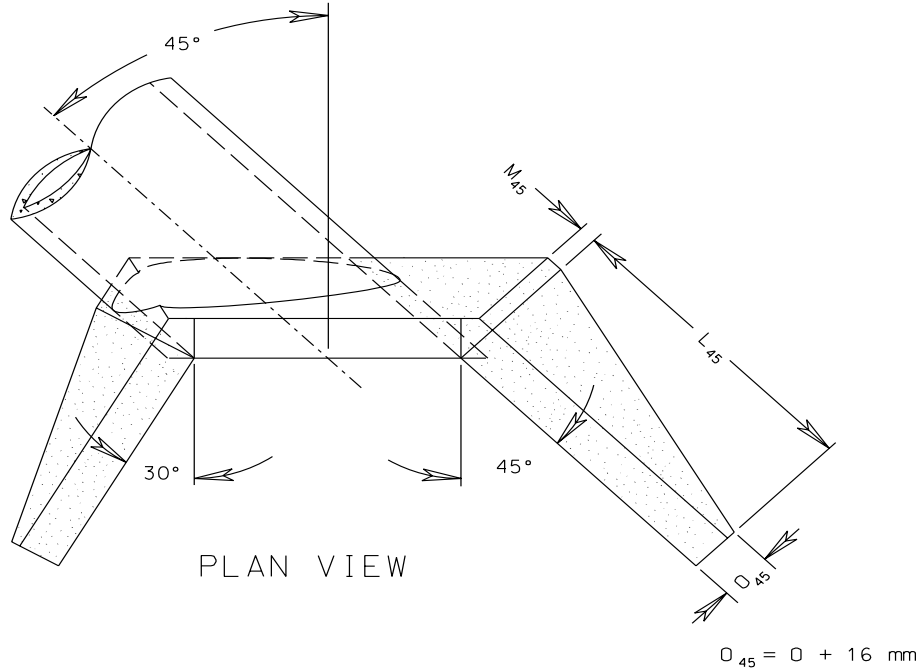

Area for computing ratio

(D) Diameter * of Culvert (mm)	Area (A)	
	1 ½ : 1 Slope	2 : 1 Slope
	Sq. Meters	Sq.Meters
1200	2.96	3.71
1350	3.61	4.54
1500	4.31	5.46
1650	5.14	6.46
1800	5.97	7.54
1950	6.96	8.81
2100	7.88	10.00

Area is given for one endwall.
Double area shown if two endwalls are used.
*Nominal sizes are shown See St'd. EW-2.
For actual "D" dimension .

TO DETERMINE RATIO	$\frac{A}{D \text{ (meters)} \times \text{Length of Culvert}}$
-----------------------	--

TABLE D-19M
COMPUTATION OF RATIOS FOR MINOR STRUCTURE EXCAVATION
STANDARD EW-2S (45 DEGREES)

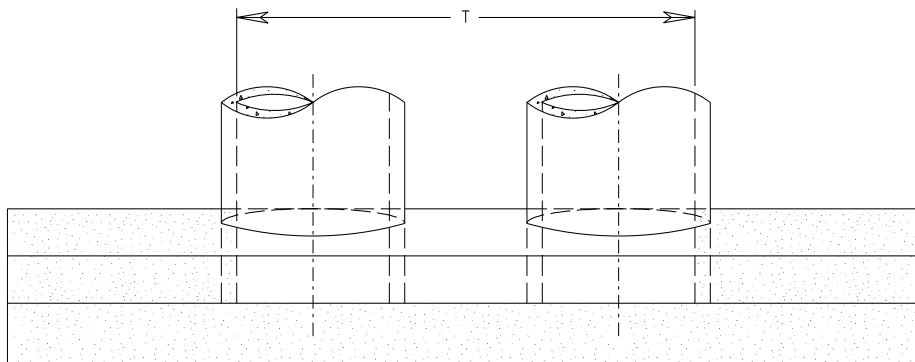

PLAN VIEW

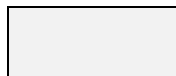

Area for computing ratio

(D) Diameter of Culvert (mm)	Area (A)					
	Double Line		Triple Line		Quadruple Line	
	Conc.	C.M.	Conc.	C.M.	Conc.	C.M.
	Sq. Meters	Sq. Meters	Sq. Meters	Sq. Meters	Sq. Meters	Sq. Meters
375			0.81	0.78	0.91	0.87
450	0.92	0.90	1.04	1.01	1.16	1.11
600	1.56	1.54	1.79	1.74	2.01	1.93
750	2.22	2.18	2.52	2.45	2.82	2.71
900	2.82	2.78	3.16	3.08	3.51	3.39
	Culvert Width (T)					
	Meters	Meters	Meters	Meters	Meters	Meters
375			1.735	1.555	2.415	2.145
450	1.26	1.16	2.070	1.870	2.880	2.580
600	1.66	1.54	2.720	2.480	3.780	3.420
750	2.07	1.91	3.390	3.070	4.710	4.230
900	2.47	2.29	4.040	3.680	5.610	5.070

Area is given for one endwall.
Double area shown if two endwalls are used.

TO DETERMINE RATIO	$\frac{A}{T \text{ (meters)} \times \text{Length of Culvert}}$
-----------------------	--

TABLE D-20M
COMPUTATION OF RATIOS FOR MINOR STRUCTURE EXCAVATION
STANDARD EW-6

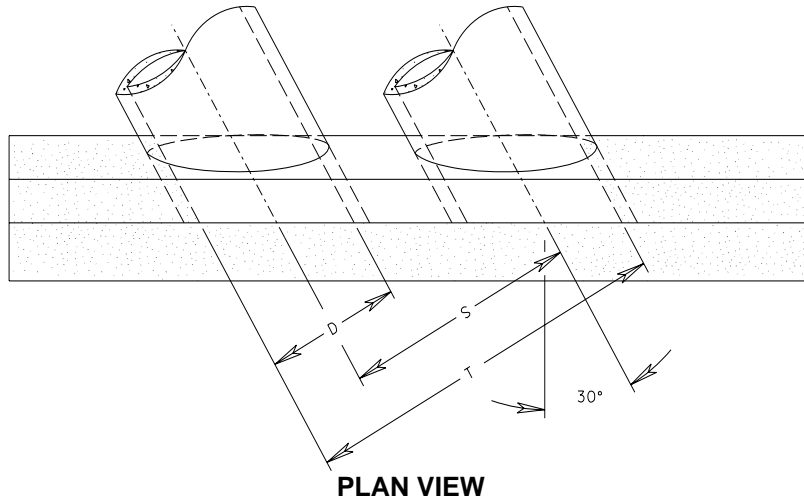

Area for computing ratio

(D) Diameter of Culvert (mm)	Area (A)					
	Double Line		Triple Line		Quadruple Line	
	Conc.	C.M.	Conc.	C.M.	Conc.	C.M.
	Sq. Meters	Sq. Meters	Sq. Meters	Sq. Meters	Sq. Meters	Sq. Meters
375			0.82	0.79	0.94	0.89
450	0.91	0.89	1.05	1.01	1.19	1.14
600	1.56	1.53	1.81	1.75	2.07	1.98
750	2.20	2.16	2.55	2.47	2.90	2.78
900	2.79	2.74	3.19	3.09	3.59	3.45
	Culvert Width (T)					
	Meters	Meters	Meters	Meters	Meters	Meters
375			1.735	1.555	2.415	2.145
450	1.26	1.16	2.07	1.870	2.880	2.580
600	1.66	1.54	2.72	2.480	3.780	3.420
750	2.07	1.91	3.39	3.070	4.710	4.230
900	2.47	2.29	4.04	3.680	5.610	5.070

Area is given for one endwall.
Double area shown if two endwalls are used.

TO DETERMINE RATIO	$\frac{A}{T \text{ (meters)} \times \text{Length of Culvert}}$
-----------------------	--

TABLE D-21M
COMPUTATION OF RATIOS FOR MINOR STRUCTURE EXCAVATION
STANDARD EW-6 (30 DEGREE)

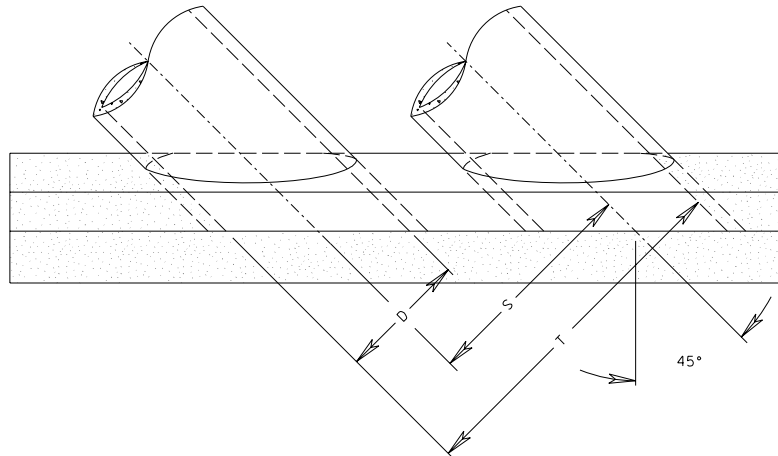

PLAN VIEW



Area for computing ratio

(D) Diameter of Culvert (mm)	Area (A)					
	Double Line		Triple Line		Quadruple Line	
	Conc.	C.M.	Conc.	C.M.	Conc.	C.M.
	Sq. Meters	Sq. Meters	Sq. Meters	Sq. Meters	Sq. Meters	Sq. Meters
375			0.84	0.81	0.98	0.93
450	0.89	0.87	1.07	1.02	1.98	1.18
600	1.54	1.51	1.86	1.79	2.17	2.07
750	2.18	2.13	2.60	2.50	3.03	2.88
900	2.73	2.68	3.22	3.11	3.71	3.54
	Culvert Width (T)					
	Meters	Meters	Meters	Meters	Meters	Meters
375			1.735	1.555	2.415	2.145
450	1.26	1.16	2.07	1.87	2.88	2.58
600	1.66	1.54	2.72	2.48	3.78	3.420
750	2.07	1.91	3.39	3.07	4.71	4.230
900	2.47	2.29	4.04	3.68	5.61	5.070

Area is given for one endwall.
Double area shown if two endwalls are used.

TO DETERMINE RATIO	$\frac{A}{T \text{ (meters)} \times \text{Length of Culvert}}$
-----------------------	--

TABLE D-22M
COMPUTATION OF RATIOS FOR MINOR STRUCTURE EXCAVATION
STANDARD EW-6S (45 DEGREE)

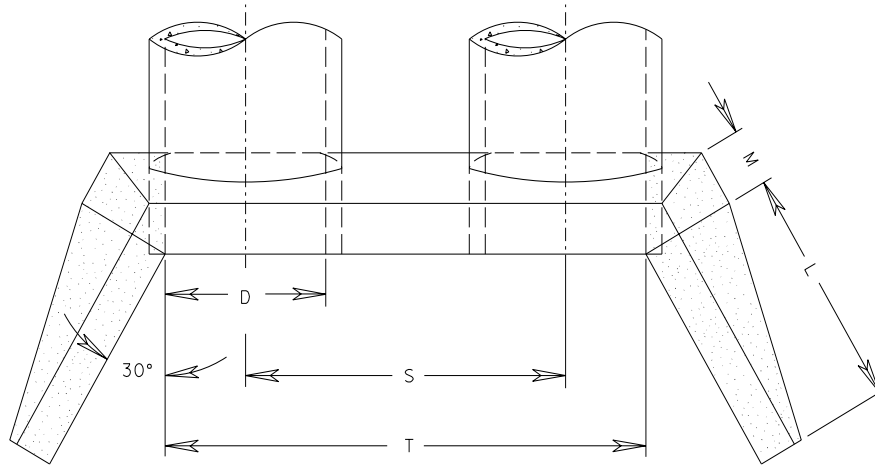

PLAN VIEW



Area for computing ratio

(D) Diameter* of Culvert (mm)	Area (A)		Culvert width (T)					
	1 ½ : 1 Slope Sq. Meters	2 : 1 Slope Sq. Meters	Double Line		Triple Line		Quadruple Line	
			Conc. Meters	C.M. Meters	Conc. Meters	C.M. Meters	Conc. Meters	C.M. Meters
1050	2.14	2.64	2.890	2.68	4.710	4.290	6.530	5.90
1200	2.48	3.12	3.300	3.06	5.380	4.900	7.460	6.74
1350	3.06	3.83	3.700	3.44	6.030	5.510	8.360	7.58
1500	3.65	4.56	4.110	3.82	6.700	6.110	9.290	8.40
1650	4.35	5.42	4.520	4.20	7.360	6.720	10.200	9.24
1800	5.09	6.35	4.920	4.58	8.010	7.330	11.100	10.08
1950	5.86	7.39	5.330	4.96	8.680	7.940	12.030	10.92
2100	6.64	8.42	5.740	5.34	9.340	8.550	12.940	11.76

Area is given for one endwall.
 Double area shown if two endwalls are used.
 *Nominal sizes are shown See St'd. EW-2.
 For actual "D" dimension .

TO DETERMINE RATIO	$\frac{A}{T \text{ (meters)} \times \text{Length of Culvert}}$
-----------------------	--

TABLE D-23M
COMPUTATION OF RATIOS FOR MINOR STRUCTURE EXCAVATION
STANDARD EW-7S

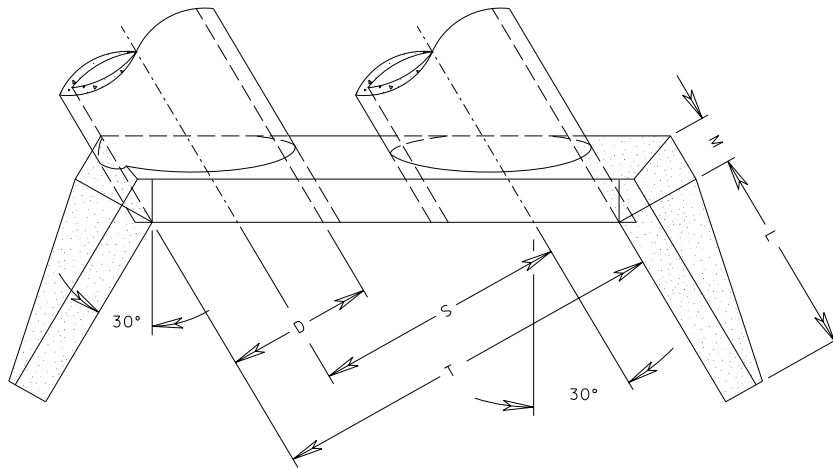

PLAN VIEW



Area for computing ratio

(D) Diameter* of Culvert (mm)	Area (A)		Culvert width (T)					
	1 ½ : 1 Slope Sq. Meters	2 : 1 Slope Sq. Meters	Double Line		Triple Line		Quadruple Line	
			Conc. Meters	C.M. Meters	Conc. Meters	C.M. Meters	Conc. Meters	C.M. Meters
1050	2.14	2.64	2.89	2.68	4.71	4.29	6.53	5.90
1200	2.48	3.12	3.30	3.06	5.38	4.90	7.46	6.74
1350	3.06	3.83	3.70	3.44	6.03	5.15	8.36	7.58
1500	3.65	4.56	4.11	3.82	6.70	6.11	9.29	8.40
1650	4.35	5.42	4.52	4.20	7.36	6.72	10.20	9.24
1800	5.09	6.35	4.92	4.58	8.01	7.33	11.10	10.08
1950	5.86	7.39	5.33	4.96	8.68	7.94	12.03	10.92
2100	6.65	8.42	5.74	5.34	9.34	8.55	12.94	11.76

Area is given for one endwall.
Double area shown if two endwalls are used.
*Nominal sizes are shown See St'd. EW-2.
For actual "D" dimension .

TO DETERMINE RATIO	$\frac{A}{T \text{ (meters)} \times \text{Length of Culvert}}$
-----------------------	--

TABLE D-24M
COMPUTATION OF RATIOS FOR MINOR STRUCTURE EXCAVATION
STANDARD EW-7S (30 DEGREE)

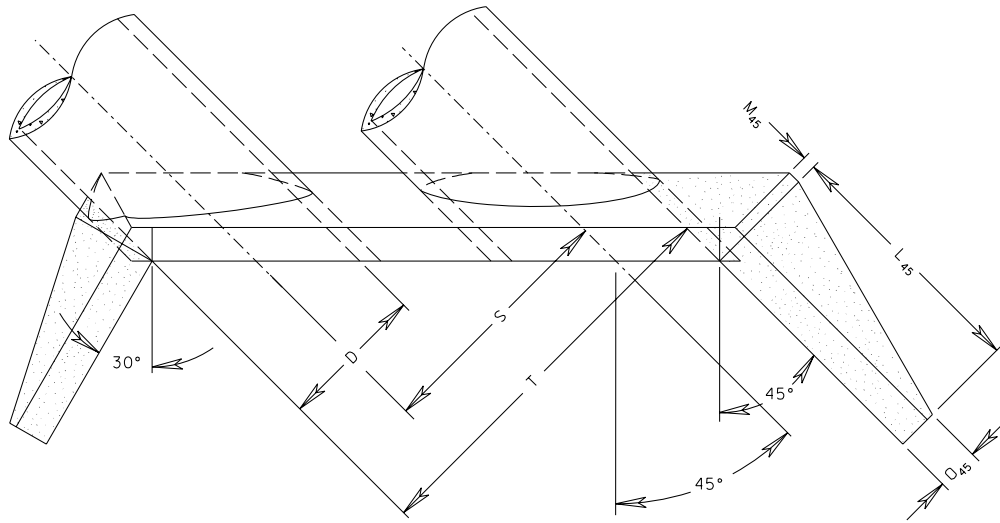

PLAN VIEW

$O_{45} = O + 16 \text{ mm}$



Area for computing ratio

(D) Diameter* of Culvert (mm)	Area (A)		Culvert width (T)					
	1 1/2 : 1 Slope Sq. Meters	2 : 1 Slope Sq. Meters	Double Line		Triple Line		Quadruple Line	
			Conc. Meters	C.M. Meters	Conc. Meters	C.M. Meters	Conc. Meters	C.M. Meters
1050	2.51	3.11	2.89	2.68	4.71	4.29	6.53	5.90
1200	2.96	3.71	3.30	3.06	5.38	4.90	7.46	6.74
1350	3.61	4.54	3.70	3.44	6.03	5.15	8.36	7.58
1500	4.31	5.46	4.11	3.82	6.70	6.11	9.29	8.40
1650	5.14	6.46	4.52	4.20	7.36	6.72	10.20	9.24
1800	5.97	7.54	4.92	4.58	8.01	7.33	11.10	10.08
1950	6.96	8.81	5.33	4.96	8.68	7.94	12.03	10.92
2100	7.88	10.00	5.74	5.34	9.34	8.55	12.94	11.76

Area is given for one endwall.
 Double area shown if two endwalls are used.
 *Nominal sizes are shown See St'd. EW-2.
 For actual "D" dimension .

TO DETERMINE RATIO	$\frac{A}{T \text{ (meters)} \times \text{Length of Culvert}}$
-----------------------	--

TABLE D-25M
COMPUTATION OF RATIOS FOR MINOR STRUCTURE EXCAVATION
STANDARD EW-7S (45 DEGREE)

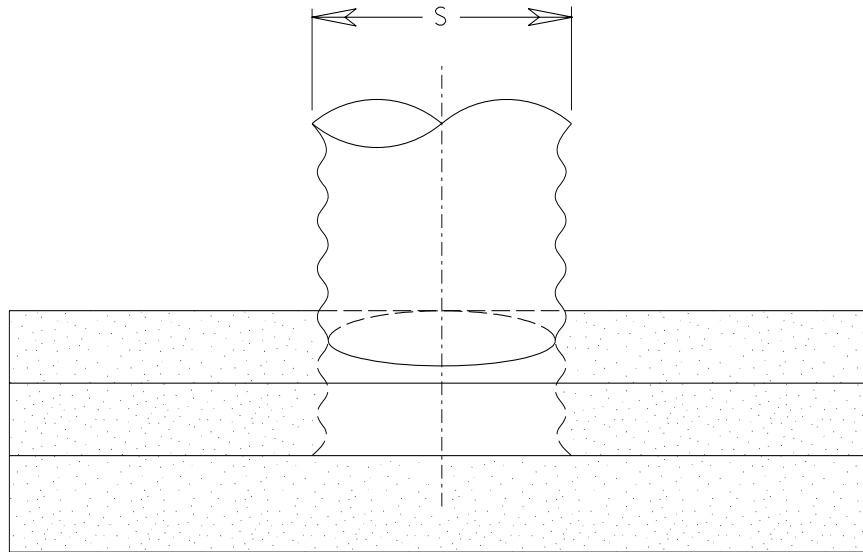

PLAN VIEW



Area for computing ratio

(S) Span of Culvert (mm)	Area (A)
	Sq. Meters
1225	2.11
*1150	2.15
1425	2.63
*1325	2.69

Area is given for one endwall.
Double area shown if two endwalls are used
* 75 mm x 25 mm corrugation dimension.

TO DETERMINE RATIO	A
	$S \text{ (meters)} \times \text{Length of Culvert}$

TABLE D-26M
COMPUTATION OF RATIOS FOR MINOR STRUCTURE EXCAVATION
STANDARD EW-9

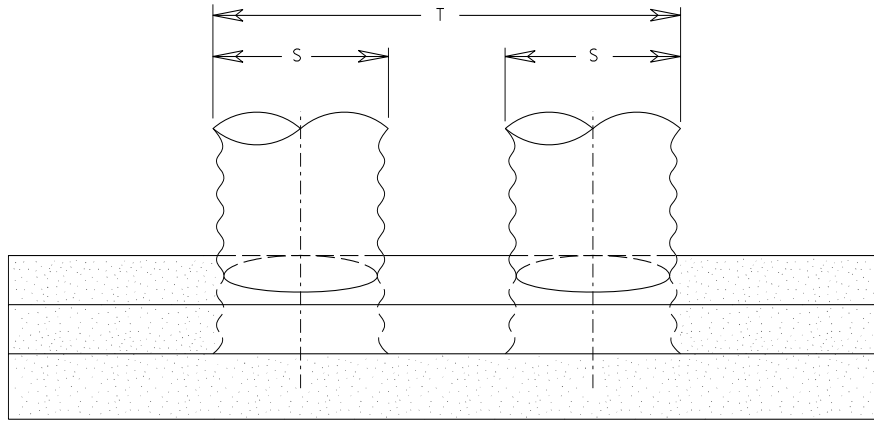

PLAN VIEW

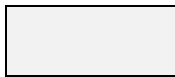

Area for computing ratio

(S) Span of Culvert (mm)	Area (A)			Culvert Width (T)		
	Double Line	Triple Line	Quadruple Line	Double Line	Triple Line	Quadruple Line
	Sq. Meters	Sq. Meters	Sq. Meters	Meters	Meters	Meters
525	0.58	0.68	0.79	1.385	2.245	3.105
600	0.83	0.96	1.09	1.540	2.480	3.420
700	1.01	1.17	1.33	1.740	2.780	3.820
875	1.57	1.82	2.08	2.095	3.315	4.535
1050	2.17	2.51	2.84	2.520	3.990	5.460
*1000	2.19	2.53	2.87	2.470	3.940	5.410
1225	2.51	2.90	3.29	2.925	4.625	6.325
*1150	2.55	2.94	3.33	2.850	4.550	6.250
1425	3.05	3.49	3.92	3.405	5.385	7.365
*1325	3.11	3.55	3.98	3.305	5.285	7.265

Area is given for one endwall.
Double area shown if two endwalls are used
* 75 mm x 25 mm corrugation dimension.

TO DETERMINE RATIO	$\frac{A}{T \text{ (meters)} \times \text{Length of Culvert}}$
-----------------------	--

TABLE D-27M
COMPUTATION OF RATIOS FOR MINOR STRUCTURE EXCAVATION
STANDARD EW-10

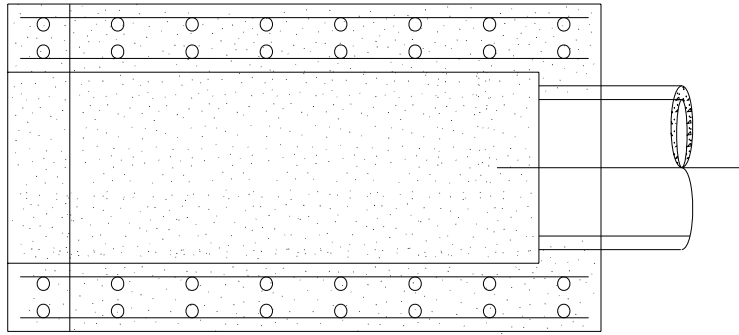

PLAN VIEW



Area for computing ratio

(D) Diameter of Culvert (mm)	Area (A)		
	3:1 Slope	4:1 Slope	6:1 Slope
	Sq. Meters	Sq. Meters	Sq. Meters
1220	10.50	13.77	20.31
1370	13.25	17.40	25.70
1520	14.40	18.30	28.05

TO DETERMINE RATIO	$\frac{A}{D \text{ (meters)} \times \text{Length of Culvert}}$
-----------------------	--

TABLE D-28M
COMPUTATION OF RATIOS FOR MINOR STRUCTURE EXCAVATION
STANDARD EW-11

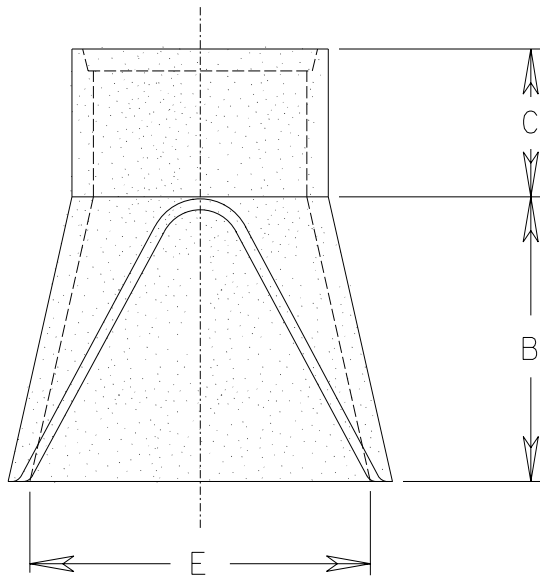

PLAN VIEW



Area for computing ratio

(D) Diameter of Culvert (mm)	Area (A)
	Sq. Meters
1200	4.44
1350	4.81
1500	5.22

Area is given for one end section.
Double area shown if two end sections are used

TO DETERMINE RATIO	$\frac{A}{D \text{ (meters)} \times \text{Length of Culvert}}$
-----------------------	--

TABLE D-29M
COMPUTATION OF RATIOS FOR MINOR STRUCTURE EXCAVATION
STANDARD ES-1

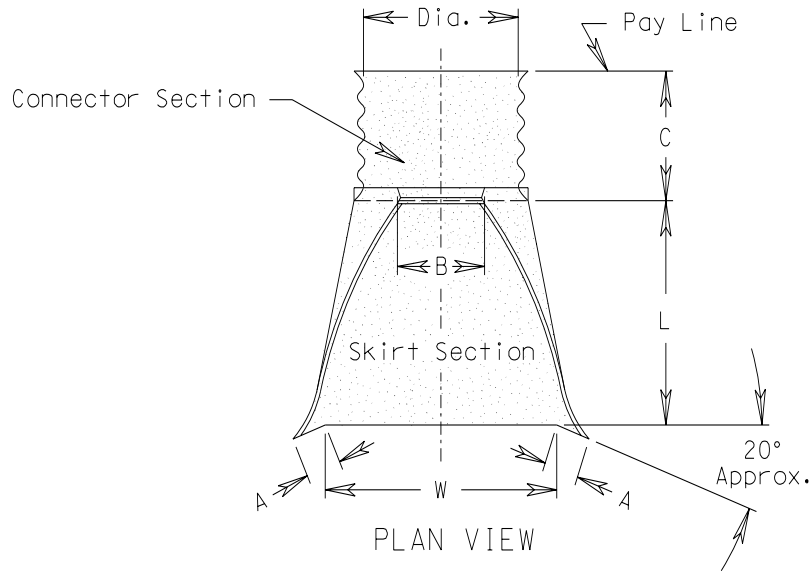

Area for computing ratio

(D) Diameter of Culvert (mm)	Area (A)
	Sq. Meters
1200	4.90
1350	5.91
1500	6.56

Area is given for one end section .
Double area shown if two end sections are used

TO DETERMINE RATIO	$\frac{A}{D \text{ (meters)} \times \text{Length of Culvert}}$
-----------------------	--

TABLE D-30M
COMPUTATION OF RATIOS FOR MINOR STRUCTURE EXCAVATION
STANDARD ES-2

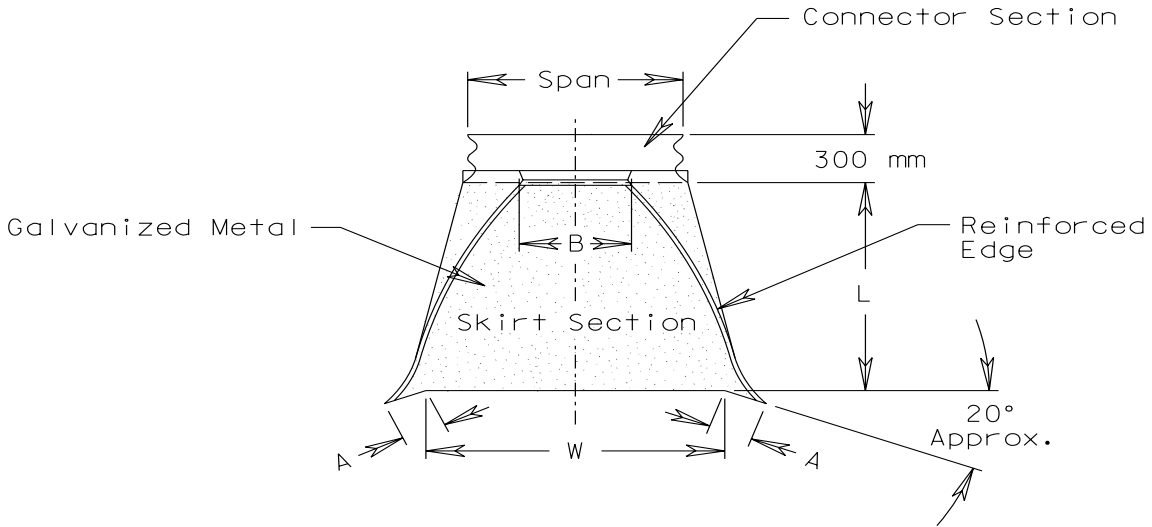

PLAN VIEW



Area for computing ratio

(S) Span of Culvert (mm)	Area (A)
	Sq. Meters
1150	2.56
1325	3.44
1500	4.39
1650	5.44

(S) Span of Culvert (mm)	Area (A)
	Sq. Meters
1150	3.29
1390	4.29
1650	5.42

Area is given for one end section.
Double area shown if two end sections are used

TO DETERMINE RATIO	$\frac{A}{S \text{ (meters)} \times \text{Length of Culvert}}$
-----------------------	--

TABLE D-31M
COMPUTATION OF RATIOS FOR MINOR STRUCTURE EXCAVATION
STANDARD ES-3

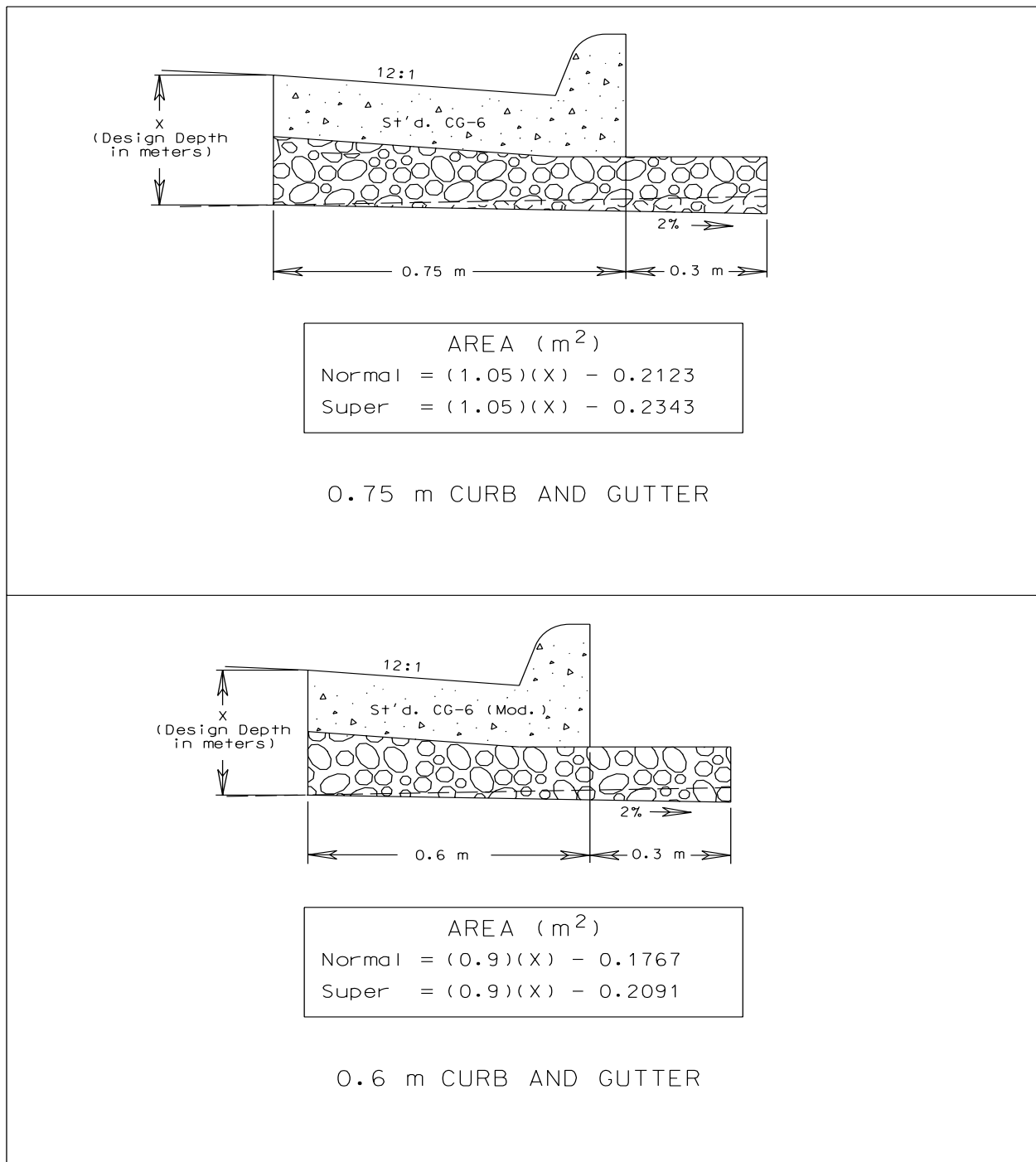
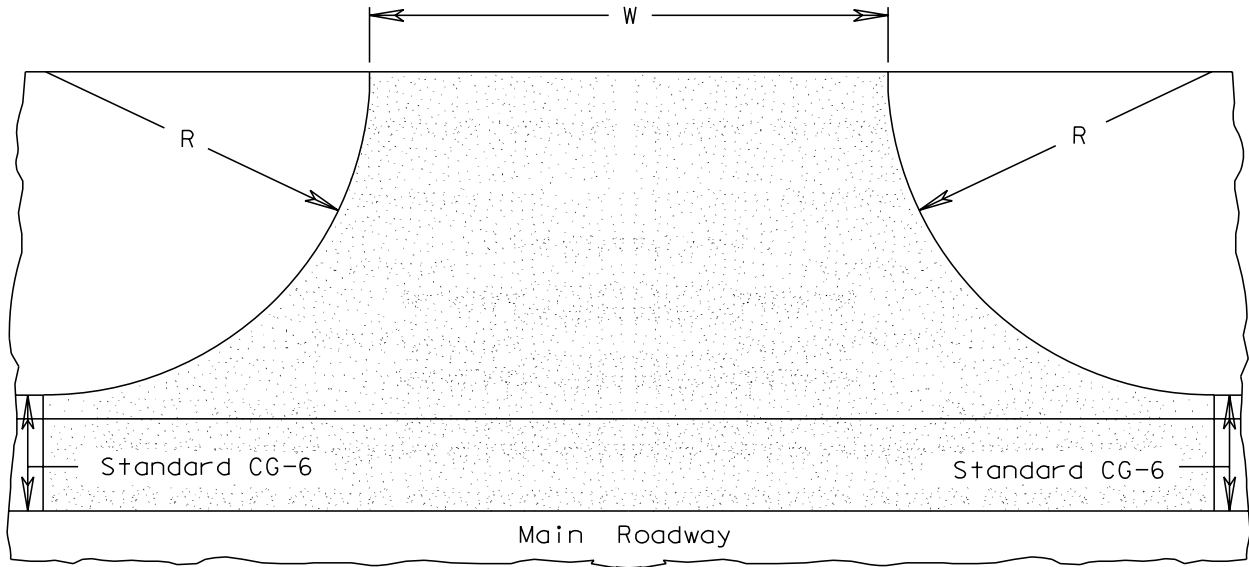
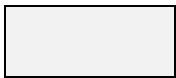

FIGURE D-2M
SUBBASE END AREAS AT CURB AND GUTTER LOCATION



W= Width of Entrance



Area for computing ratio

Width Of Entrance (Meters)	No Accessible Route (R = 1.35 m)	Accessible Route (R = 2.25m)
	Sq. Meters.	Sq. Meters.
4	11.21	17.55
5	13.31	20.55
6	15.41	23.55
7	17.51	26.55
8	19.61	29.55
9	21.71	32.55
10	23.81	35.55
11	25.91	38.55
12	28.01	41.55
13	30.11	44.55
14	32.21	47.55
15	34.31	50.55
Each Additional 0.1 m	0.21	0.30

TABLE D-32M
AREAS FOR ENTRANCE GUTTER
STANDARD CG-9D

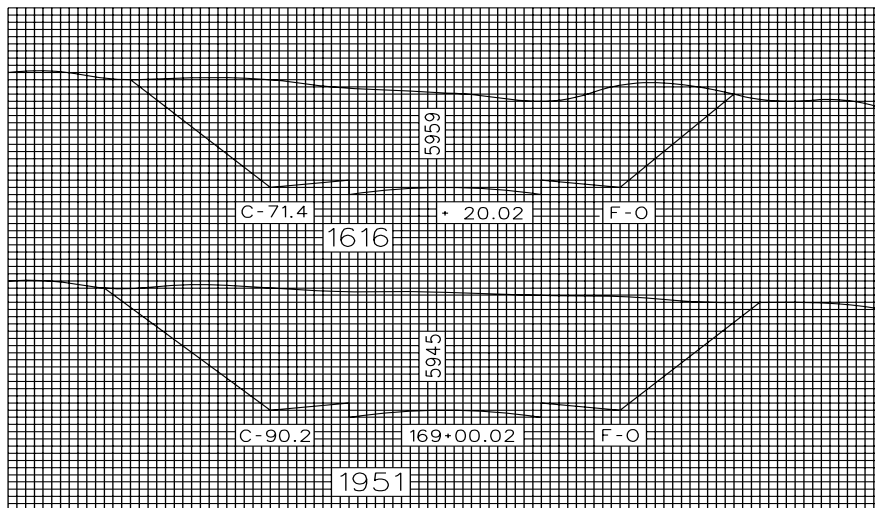

The cut area of station 163+00.02 is 90.2 square meters, and the area of station 169+20.02 is 71.4 square meters. To find the average area of the two, we would add the two and divide by two.

$$\text{Thus, } \frac{90.2 + 71.4}{2} = \frac{161.6}{2} = 80.8 \text{ Square Meters (average)}$$

Now we must find the volume of the area between the two stations. The cross section has an average of 80.8 square meters and there is 20 meters between stations. Therefore, 80.8 multiplied by 20 equals 1616 cubic meters to be removed from between these stations.

Therefore, the volume in m^3 between two stations 20 m apart equals 10 (ten) times the sum (in m^2) of the end areas.

The formula used to determine the volume of earthwork is called the AVERAGE END AREA METHOD and is noted below. Examine it closely.

$$\text{Volume} = \frac{L (A' + A'')}{2}$$

L = distance between stations (m)
 A' = area of one station (m^2)
 A'' = area of second station (m^2)
 2 gets the average of A' & A''

EXAMPLE

$$\text{Volume (in } m^3) = \frac{20 (90.2 + 71.4)}{2} = 1616$$

FIGURE D-4M
EARTHWORK QUANTITY COMPUTATIONS