

STP-2

SIGN POSTS NOT REQUIRING BRACING

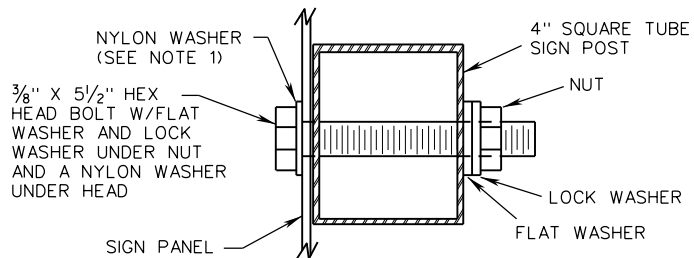

SINGLE SIGN PANEL DETAIL

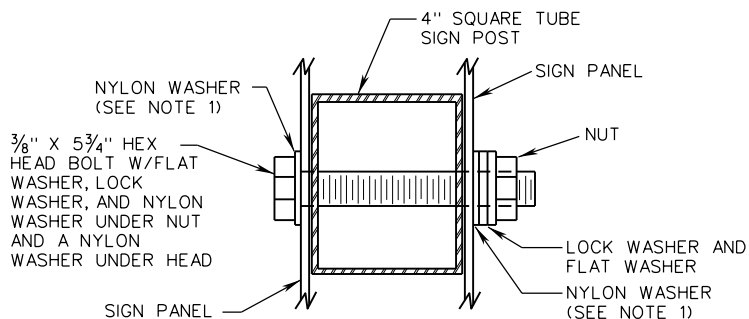

BACK-TO-BACK SIGN PANEL DETAIL

NOTES:

1. NYLON WASHER SHALL BE 1/16" THICK MINIMUM WITH AN OUTSIDE DIAMETER OF 1" AND AN INSIDE DIAMETER OF 7/16".
2. DRIVE RIVET SHALL BE 3/16" OR 3/8" ALUMINUM FLAT HEAD RIVET WITH STEEL PINS AND NYLON OR RUBBER WASHER.
3. DRIVE RIVET SHALL NOT BE USED FOR SIGNS WITHOUT BRACING.

SIGN POSTS REQUIRING BRACING

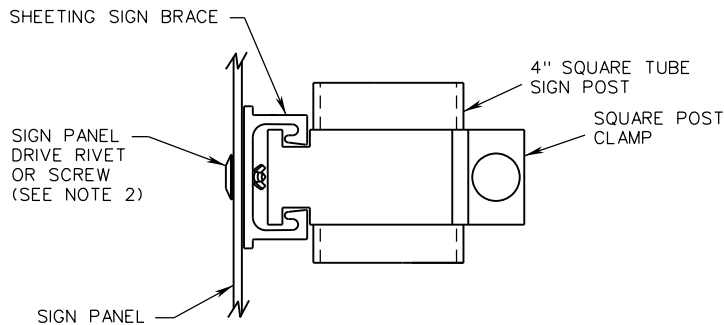

SINGLE SIGN PANEL DETAIL

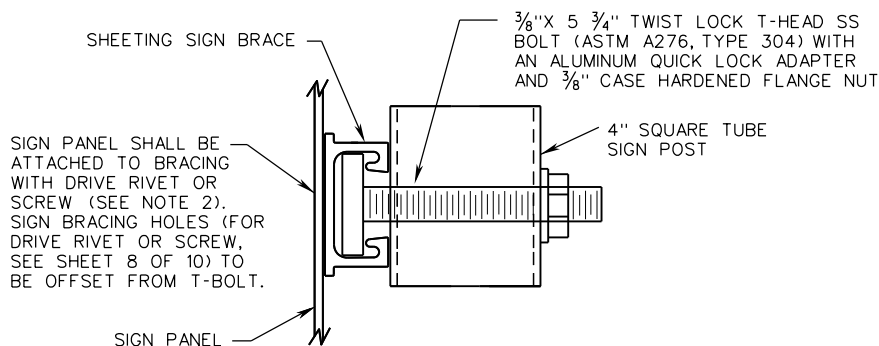

SINGLE SIGN PANEL ALTERNATE METHOD DETAIL

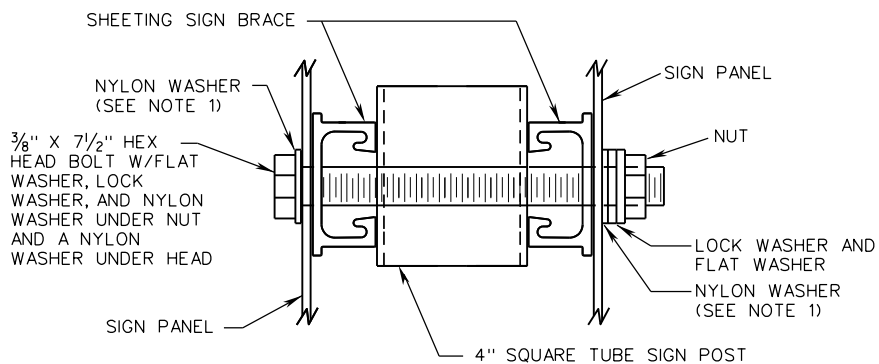

BACK-TO-BACK SIGN PANEL DETAIL

A COPY OF THE ORIGINAL SEALED AND SIGNED DRAWING IS ON FILE IN THE CENTRAL OFFICE.

**FOUR INCH SQUARE TUBE SIGN POST
SIGN BRACING AND SIGN PANEL ATTACHMENT DETAILS**

VIRGINIA DEPARTMENT OF TRANSPORTATION

SPECIFICATION
REFERENCE

700



ROAD AND BRIDGE STANDARDS

SHEET 10 OF 10

REVISION DATE

1321.49

NEW 09/18