

NOTES:

- PIN AND CONNECTORS SHALL BE ASTM-A36. REINFORCING STEEL BARS SHALL BE ASTM A 615 GRADE 60. ONE CONNECTOR PIN ASSEMBLY WITH EACH BARRIER SECTION.

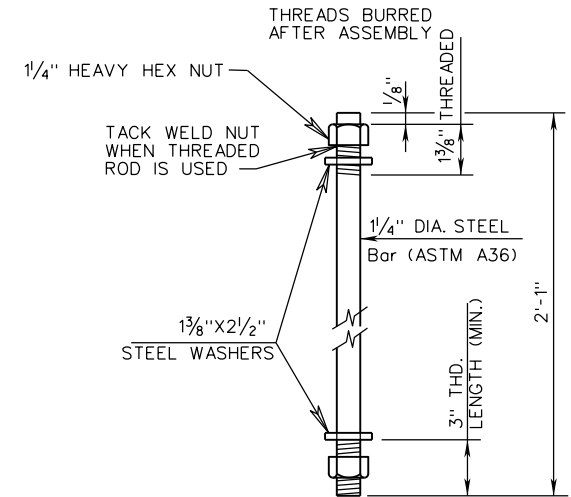

CONNECTOR PIN ASSEMBLY
GALVANIZE AFTER FABRICATION

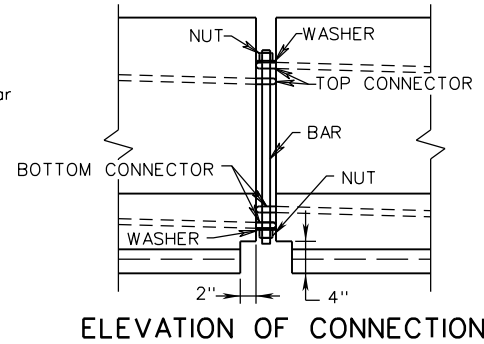
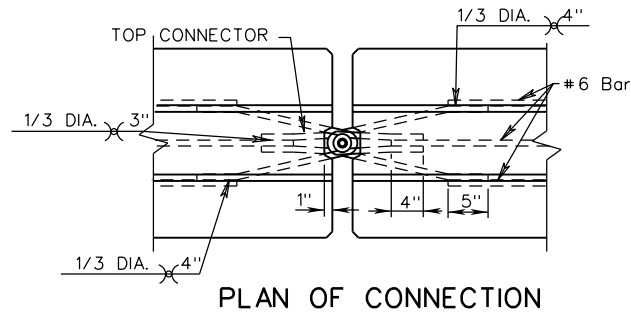
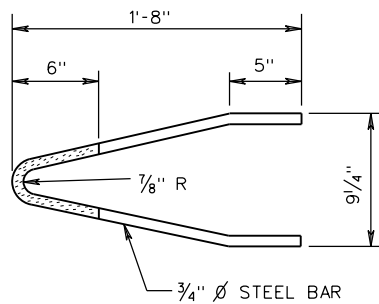

BOTTOM CONNECTOR
GALVANIZE AFTER FORMING

NOTE: ENTIRE CONNECTOR MAY BE GALVANIZED.

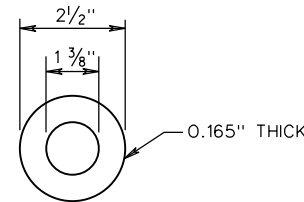
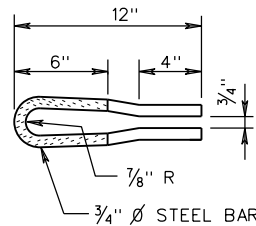

SPECIFICATION REFERENCE

105
512

PRECAST TRAFFIC BARRIER SERVICE CONCRETE

(FOR TEMPORARY USE)
VIRGINIA DEPARTMENT OF TRANSPORTATION



ROAD AND BRIDGE STANDARDS

REVISION DATE

7/16

SHEET 2 OF 2

502.06