

PLAN

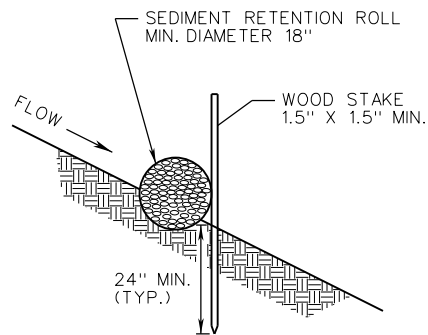

SECTION A-A

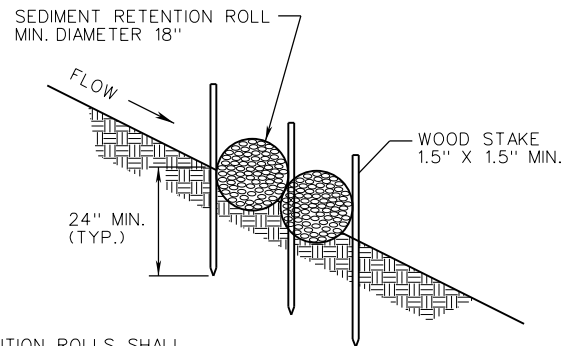

SECTION B-B

SEDIMENT RETENTION ROLLS SHALL BE EMBEDDED ONE THIRD THE SSR DIAMETER EXCEPT WHEN PLACED OVER STANDARD EC-2 OR EC-3.

**NOTES:**

1. THE STANDARD FOR SEDIMENT RETENTION ROLLS (SRR) SHALL INCLUDE COMPOST FILTER SOCKS AND SEDIMENT TUBES, UNLESS SPECIFICALLY NOTED.
2. SRR SHALL BE INSTALLED ALONG THE GROUND CONTOUR, OR AT THE TOE OF SLOPES TO HELP REDUCE THE EFFECTS OF SOIL EROSION AND TO RETAIN SEDIMENT. SRR APPLIED AT THE TOE OF A SLOPE SHOULD BE PLACED 10' AWAY FROM THE TOE. SRR SHALL NOT BE USED IN STREAMS.
3. SEDIMENT TUBES USED IN SLOPE APPLICATIONS MAY REMAIN IN PLACE TO BIODEGRADE. COMPOST FILTER SOCKS SHOULD BE REMOVED FROM SLOPES AFTER STABILIZATION IS COMPLETE. THIS MAY BE ACCOMPLISHED BY CUTTING THE SOCK OPEN AND SPREADING THE FILL MATERIAL ON THE SITE. ALL NON-BIODEGRADABLE MATERIAL AND STAKES SHALL BE REMOVED.
4. ONLY SSR PRODUCTS LISTED ON THE APPROVED PRODUCTS LIST MAY BE USED.
5. SEDIMENT RETENTION ROLLS (SRR) USED FOR SLOPE APPLICATIONS WILL BE PAID IN ACCORDANCE WITH 603.
6. PAYMENT SHALL INCLUDE ALL MATERIALS AND LABOR NECESSARY FOR INSTALLATION, MAINTENANCE AND REMOVAL.
7. SEDIMENT SHALL BE REMOVED FROM BEHIND THE SRR WHEN IT HAS ACCUMULATED TO ONE-HALF THE EXPOSED HEIGHT OF THE STRUCTURE AND PAID FOR AS SEDIMENT REMOVAL PER CUBIC YARD.
8. SRR SHALL BE INSTALLED WITH WOODEN STAKES (MIN. 1.5" X 1.5" ACTUAL). THE STAKE SHALL BE EMBEDDED A MINIMUM OF 2'.
9. IF MORE THAN ONE SRR IS PLACED IN A ROW IN A SLOPE APPLICATION, THE TUBES SHALL BE OVERLAPPED A MINIMUM OF 24" TO PREVENT FLOW AND SEDIMENT FROM PASSING THROUGH THE JOINT.
10. SRR SHALL NOT BE USED ON PAVEMENT, ROCKY SOILS, OR AT ANY OTHER LOCATION WHERE THE STAKES CANNOT BE DRIVEN TO THE REQUIRED DEPTH.

SPECIFICATION REFERENCE

244  
303  
603

A COPY OF THE ORIGINAL SEALED AND SIGNED DRAWING IS ON FILE IN THE CENTRAL OFFICE.

**SEDIMENT RETENTION ROLL  
SLOPE INTERRUPTER**

VIRGINIA DEPARTMENT OF TRANSPORTATION



ROAD AND BRIDGE STANDARDS

REVISION DATE

SHEET 1 OF 1

NEW 07/16

113.19