

EW-2SPC

DIMENSIONS

ID	H	W	1/2:1 SLOPE				2:1 SLOPE		a	b
			L 30°		L 45°		L 30°	L 45°		
			L 30°	L 45°	L 30°	L 45°				
42"	5'-6"	8'-0"	6'-7 1/2"	8'-0"	8'-8"	10'-6"	0'-4 1/2"	0'-3 1/2"		
48"	6'-0"	8'-10"	7'-6"	9'-2 1/2"	9'-9 3/4"	12'-0"	0'-5"	0'-4"		
54"	6'-6"	9'-8"	8'-4 1/2"	10'-3"	10'-11 1/2"	13'-6"	0'-5 3/4"	0'-4 1/2"		
60"	7'-0"	10'-6"	9'-3"	11'-3 1/2"	12'-1 1/4"	14'-10 1/4"	0'-6 1/4"	0'-5"		
66"	7'-7"	11'-6"	10'-1 1/4"	12'-4 1/2"	13'-3 1/2"	16'-4"	0'-7"	0'-5 1/2"		
72"	8'-2"	12'-4"	11'-0"	13'-5 1/2"	14'-5 1/2"	17'-8"	0'-7"	0'-6"		
78"	8'-8 1/2"	13'-0"	11'-10"	14'-6"	15'-7"	19'-0"	0'-7"	0'-6 1/2"		
84"	9'-3"	13'-10"	12'-8 1/2"	15'-6"	16'-9"	20'-6"	0'-7"	0'-7"		
90"	9'-11"	14'-10"	13'-7"	16'-7 1/2"	17'-11"	21'-11"	0'-7"	0'-7 1/2"		
96"	10'-7"	15'-10"	14'-5 1/4"	17'-8 1/4"	19'-1"	23'-4"	0'-7"	0'-8"		

NOTES:

1. CONCRETE TO BE 4000 PSI MINIMUM COMPRESSIVE STRENGTH.
2. REINFORCING STEEL IN ACCORDANCE WITH ASTM A-615 (REINFORCING BARS).
3. PIPE OPENINGS IN PRECAST DRAINAGE UNITS SHALL NOT EXCEED 4 INCHES AT ANY GIVEN POINT BETWEEN THE PIPE AND THE PRECAST UNIT.
4. DIMENSIONS SHOWN ARE MINIMUM. ACTUAL MEASUREMENTS MAY VARY WITH MANUFACTURER'S TOLERANCES.
5. IN NO CASE SHALL TOP OF ENDWALL PROTRUDE ABOVE FILL SLOPE, DITCH SLOPE, OR SHOULDER.
6. HEADWALL TO BE BEVELED IN ALL AREAS EXCEPT WHERE A CONFLICT WITH INVERT OR WINGWALL OCCUR.
7. BEVEL EDGE AS REQUIRED ON THE HEADWALL AT THE INLET END OF THE CULVERT (WHERE THE FLOW ENTERS THE CULVERT).
8. HEADWALL AT THE OUTLET END OF THE CULVERT MAY BE EITHER SQUARE EDGE OR BEVEL EDGE.
9. 3/4" CHAMFER MAY BE PROVIDED ON ALL EDGES AT MANUFACTURER'S OPTION.

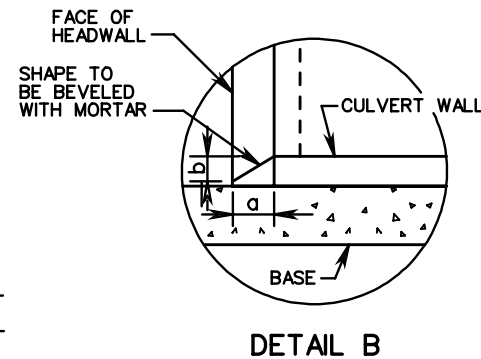
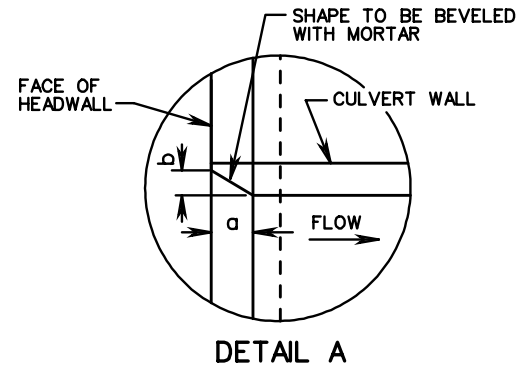
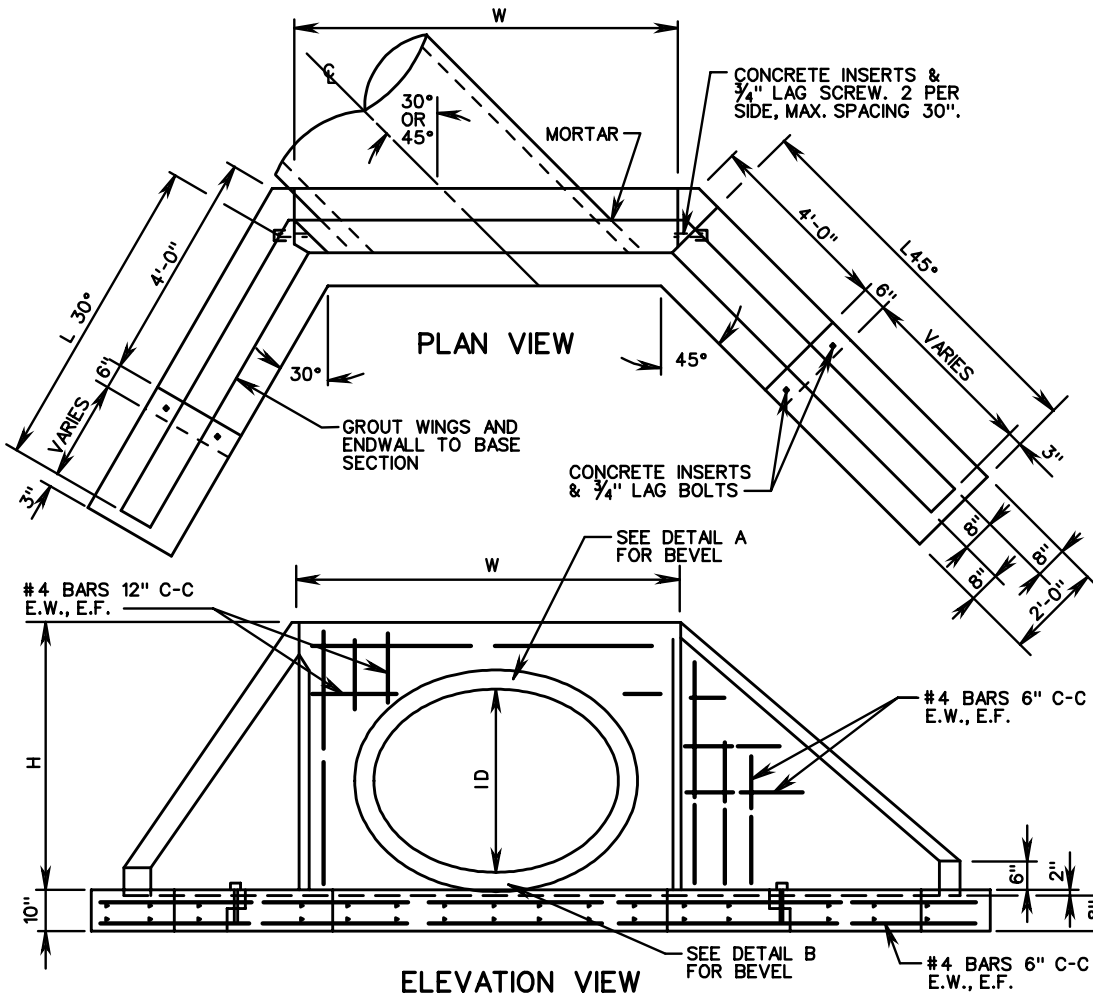

ROAD AND BRIDGE STANDARDS

PRECAST ENDWALL FOR PIPE CULVERTS

42" - 96" CIRCULAR PIPES WITH 30° AND 45° SKEW

VIRGINIA DEPARTMENT OF TRANSPORTATION

SPECIFICATION REFERENCE

SHEET 1 OF 1

REVISION DATE

105
302

101.10