

TYPICAL NOTES:

SEE SHEET 1 FOR DETAILS

1. 1 1/2" DIAMETER WIRE INLETS SHALL BE PROVIDED AT THE FOLLOWING LOCATIONS:
 - A. ON SPAN STRUCTURES ON THE FRONT LEG OF END POLE 12" BELOW BOTTOM CHORD.
 - B. ON CANTILEVER AND BUTTERFLY STRUCTURES ON POLE 12" BELOW BOTTOM CHORD.
 - C. ON SPAN STRUCTURES ON THE UNDERSIDE OF THE BOTTOM CHORD AT CENTERLINE BEHIND FIRST SIGN PANEL FROM EACH END POLE.
 - D. ON CANTILEVER AND BUTTERFLY STRUCTURES ON THE UNDERSIDE OF THE BOTTOM CHORD AT CENTERLINE BEHIND FIRST SIGN PANEL FROM POLE.
2. ALL UNUSED WIRE INLETS SHALL BE CAPPED WATER TIGHT.
3. OVERHEAD SIGN STRUCTURE POLES SHALL BE LOCATED SUCH THAT THE NEAR SIDE EDGE OF THE FOUNDATION IS OUTSIDE OF THE GUARDRAIL DEFLECTION DISTANCE.
4. NO MORTAR, GROUT, OR CONCRETE SHALL BE PLACED BETWEEN BOTTOM OF BASE PLATE AND TOP OF PEDESTAL.
5. VERTICAL CLEARANCE FOR OVERHEAD SIGN STRUCTURES SHALL BE AS FOLLOWS:
 - A. CANTILEVER OR SPAN SIGN STRUCTURE:
17'-6" FROM BOTTOM OF LOWEST LUMINAIRE ASSEMBLY (OR BOTTOM OF SIGN PANEL IF NO SIGN LIGHTING IS PRESENT) TO HIGHEST POINT OF THE TRAVEL LANES OR SHOULDER.
 - B. BUTTERFLY SIGN STRUCTURE THAT OVERHANGS THE TRAVEL LANE, SHOULDER OR MEDIAN:
17'-6" FROM BOTTOM OF LUMINAIRE ASSEMBLY (OR BOTTOM OF SIGN PANEL IF NO SIGN LIGHTING IS PRESENT) TO THE HIGHEST POINT OF THE PORTION OF THE ROAD SURFACE OR MEDIAN THAT IS UNDERNEATH THAT SIGN.
 - C. BUTTERFLY SIGN STRUCTURE THAT DOES NOT OVERHANG THE TRAVEL LANE, SHOULDER OR MEDIAN:
14'-6" FROM BOTTOM OF LUMINAIRE ASSEMBLY (OR BOTTOM OF SIGN PANEL IF NO SIGN LIGHTING IS PRESENT) TO THE HIGHEST POINT OF THE ROAD SURFACE FOR THE TRAVEL LANES OR SHOULDER IN THAT DIRECTION OF TRAVEL.
6. ALL SIGN PANELS SHALL BE A MAXIMUM OF 21'-0" FROM THE BOTTOM OF SIGN PANELS TO THE HIGHEST POINT OF THE TRAVEL LANE OR SHOULDER FOR THAT DIRECTION OF TRAVEL.
7. TOP OF FOUNDATIONS SHALL BE 2'-0" MINIMUM ABOVE FINISHED GRADE. FOR FOUNDATIONS ADJACENT OR WITHIN A SIDEWALK, TOP OF FOUNDATIONS SHALL BE A MINIMUM OF 3" ABOVE FINISHED GRADE.
8. FOUNDATIONS SHALL NOT BE LOCATED IN THE BASE OR SIDES OF DRAINAGE DITCHES.
9. EACH HORIZONTAL CHORD SHALL BE ATTACHED TO A POLE.
10. SEE STANDARD HH-1 FOR HANDHOLE DETAILS.
11. SEE STANDARD VS-1 FOR VARMINT SCREEN DETAILS.
12. A "J" HOOK FOR WIRE SUPPORT SHALL BE PLACED NEAR ALL HANDHOLES THAT ARE LOCATED MORE THAN 4 FEET UP THE STRUCTURE.
13. ALL SIGN STRUCTURES SHALL BE DESIGNED TO SUPPORT THE FUTURE ADDITION OF ONE CCTV CAMERA AT THE TOP CORNER OF ONE COLUMN, AND THE FUTURE ADDITION OF ONE 500-POUND POLE MOUNTED CABINET ATTACHED TO ONE COLUMN, UNLESS SUCH DEVICES ARE ALREADY REQUIRED IN THE CONTRACT DOCUMENTS. SEE STANDARD MP-3 FOR CCTV CAMERA DEAD LOAD AND SURFACE AREA REQUIREMENTS.

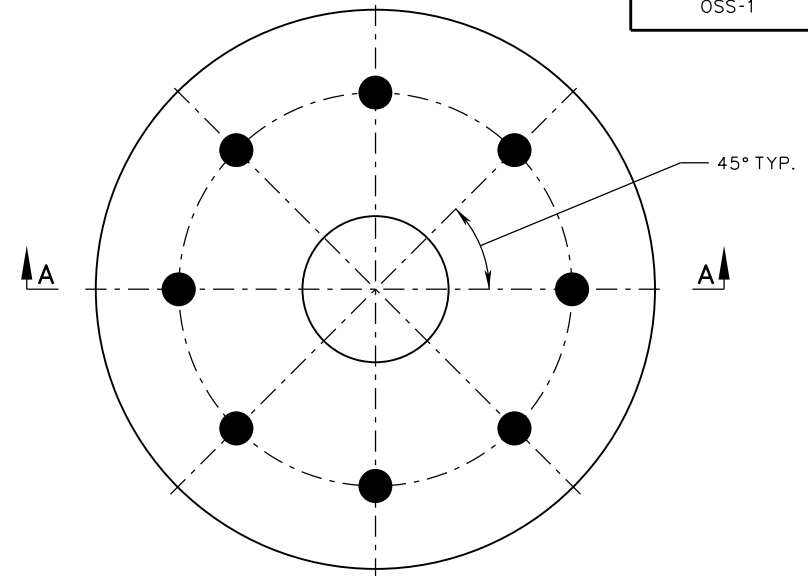

PLAN FOR SINGLE POLE SUPPORT

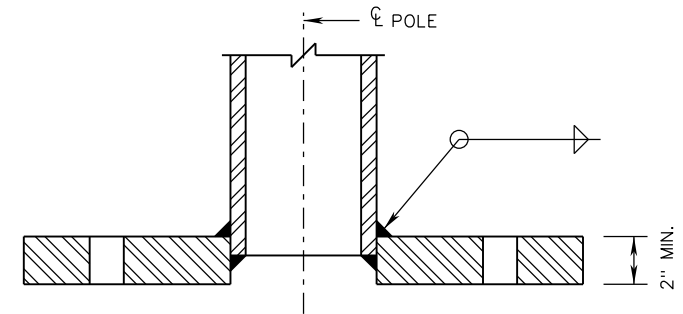

SECTION A-A

TYPICAL SOCKETED BASE PLATE CONNECTION

NOTES:

1. ALL OVERHEAD SIGN STRUCTURES HAVING A SINGLE POLE, OR A SINGLE POLE AT EACH END, SHALL HAVE A MINIMUM OF EIGHT (8) TWO-INCH DIAMETER (MINIMUM) ANCHOR BOLTS. STRUCTURES WITH MORE THAN ONE POLE AT EACH END SHALL HAVE A MINIMUM OF FOUR (4) TWO-INCH DIAMETER (MINIMUM) ANCHOR BOLTS PER POLE.
2. ALL END POLE COLUMNS SHALL BE JOINED TO THE BASE PLATE USING A SOCKETED CONNECTION OR FULL PENETRATION GROOVE WELD WITH A BACKING RING.
3. SEE STANDARD AB-1 FOR TYPICAL ANCHOR BOLT DETAILS.

SPECIFICATION REFERENCE
700

A COPY OF THE ORIGINAL SEALED AND SIGNED DRAWING IS ON FILE IN THE CENTRAL OFFICE.

OVERHEAD SIGN STRUCTURE
TYPICAL NOTES AND SOCKETED BASE PLATE CONNECTION

VIRGINIA DEPARTMENT OF TRANSPORTATION

VDOT ROAD AND BRIDGE STANDARDS	
REVISION DATE	SHEET 2 OF 7
04/19	1324.11