

SHIM DETAIL

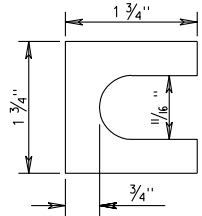

Furnish 2 @ .063" thick and 2 @ .032" thick shims per post. Shims shall be fabricated from brass conforming to ASTM B36 or from stainless steel with a minimum chromium content of 11.50% . No more than 2 shims shall be used per bolt with a maximum of 4 shims per post.

POST CLAMP DETAIL

Galvanized Gray - Iron or Aluminum Casting

Centerline Hole for 3/8" diameter Square Head Stainless Steel Bolt x 2 1/4" long with Self-locking Nut and one Flat Washer.

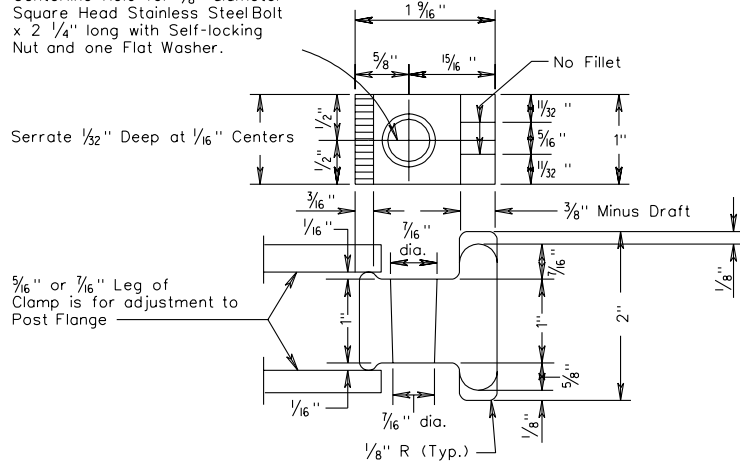

ALTERNATE FASTENING

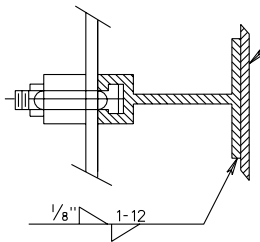

Attach sign to tee bar by using 1100-H18 aluminum alloy 1/4" - 20 x 1/2" long studs electrically welded to back of sign panel by the Capacitor Discharge Method. Maximum horizontal spacing of studs shall be on 6" centers beginning 1" from each end of tee bar. 7075-T6 aluminum alloy spring lockwasher 0.255" I.D. x 0.493" O.D. x 0.062" thick shall be provided for each stud. 6262-T9 aluminum alloy 1/4" - 20 hexagon head nut, torque to 25 in lbs. shall be provided for each stud.

TEE CROSS SECTION

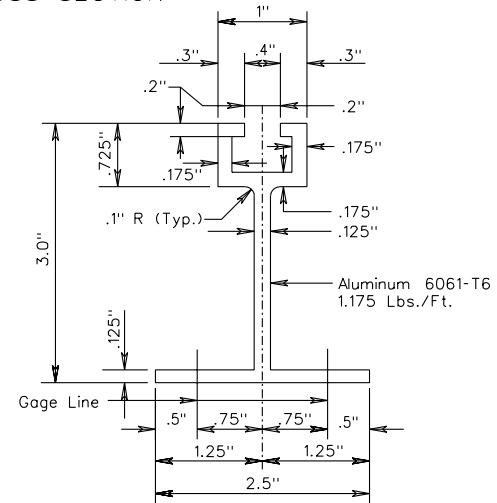

TYPICAL DETAILS FOR TYPE VA SIGN STRUCTURES