

NOTES:

IF THE CONTRACTOR ELECTS TO USE THE OPTIONAL CONSTRUCTION JOINTS, TRANSVERSE JOINTS FOR CRACK CONTROL AND EXPANSION JOINTS ARE TO BE PROVIDED IN BOTH FOOTING AND BARRIER AT THE SAME LOCATION.

TRANSVERSE JOINTS ARE TO COINCIDE WITH JOINTS IN ADJACENT PAVEMENT WITH A MAXIMUM SPACING OF 20 FT. C-C.

CONCRETE MEDIAN BARRIER MAY BE CAST IN PLACE OR SLIP-FORMED.

HORIZONTAL REINFORCING STEEL BARS ARE TO BE SEPARATE AT ALL EXPANSION AND CONTRACTION JOINTS. A 2" CONCRETE COVER IS REQUIRED OVER THE ENDS OF THE REINFORCING STEEL.

BARRIER DELINEATOR SIZE, COLOR AND SPACING SHALL BE IN ACCORDANCE WITH THE SPECIFICATIONS. COST OF DELINEATOR SHALL BE INCLUDED IN THE PRICE BID FOR MEDIAN BARRIER. REFLECTIVE SURFACE OF BARRIER DELINEATOR, IN ALL INSTANCES, SHALL BE FACING THE ONCOMING TRAFFIC.

CONCRETE SHALL BE CLASS A3 IF CAST IN PLACE, 4000 PSIF PRECAST.

▲ DEPTH OF CONCRETE BASE MAY BE EXTENDED AT THE CONTRACTOR'S OPTION TO COINCIDE WITH BOTTOM OF PAVEMENT COURSE IN WHICH BASE TERMINATES; HOWEVER, THE COST OF ADDITIONAL CONCRETE SHALL BE INCLUDED IN UNIT PRICE BID PER LINEAR FT. OF BARRIER.

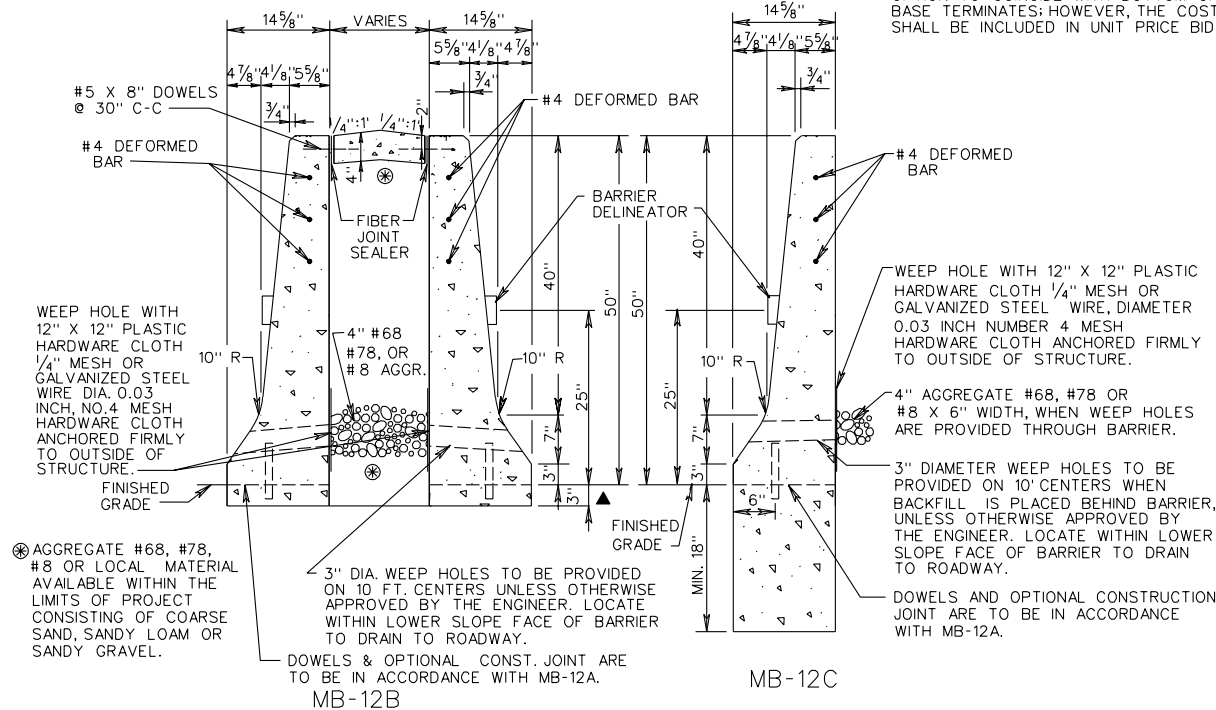

DESIGN SPEED	FLARE RATES		
	INSIDE SHY LINE	BEYOND SHY LINE	
MPH	SHY LINE LS	FLARE RATE	FLARE RATE
70	10'	30:1	20:1 *
60	8'	26:1	17:1 *
50	6.5'	21:1	14:1 *
40	5'	17:1	11:1 *
30	3.5'	13:1	8:1 *

\* SUGGESTED MAXIMUM FLARE RATE FOR RIGID BARRIER SYSTEMS.

SHEET 2 OF 2

SPECIFICATION REFERENCE

105  
502

CONCRETE MEDIAN BARRIER (TALL WALL)

VIRGINIA DEPARTMENT OF TRANSPORTATION