

REVISED ON 7-03

REVISED 1-04

PR-7

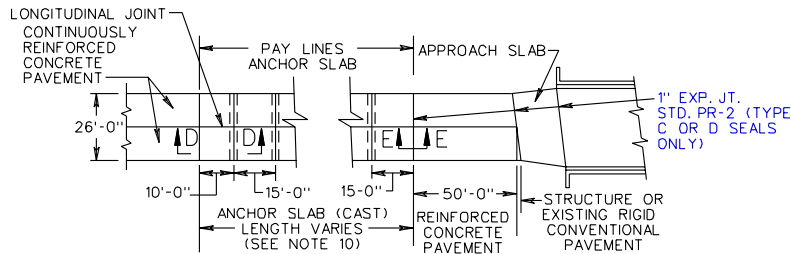

PLAN VIEW ANCHOR SLAB TYPE I

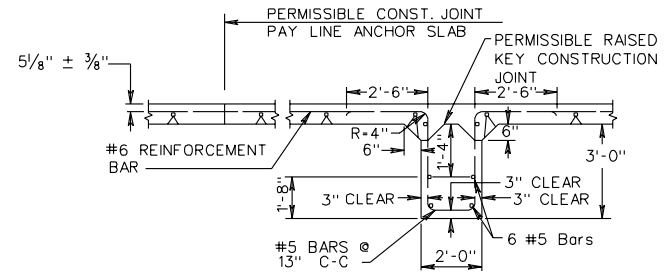

SECTION D-D

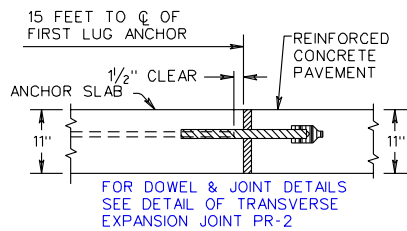

SECTION E-E ANCHOR SLAB TYPE I

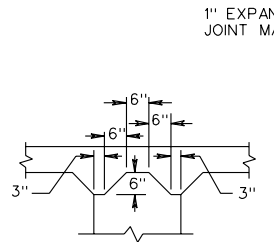

DETAIL-RAISED KEY CONSTRUCTION JOINT

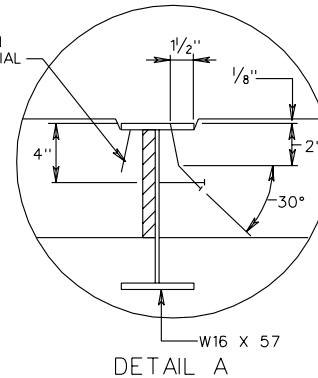

DETAIL A

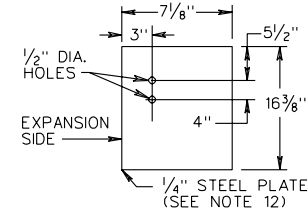

ANCHOR SLAB TYPE II END PLATE DETAIL

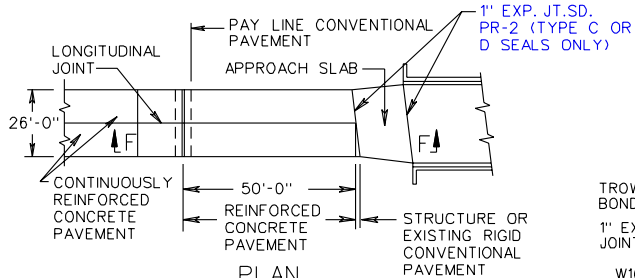

PLAN ANCHOR SLAB TYPE II (SEE NOTE 11)

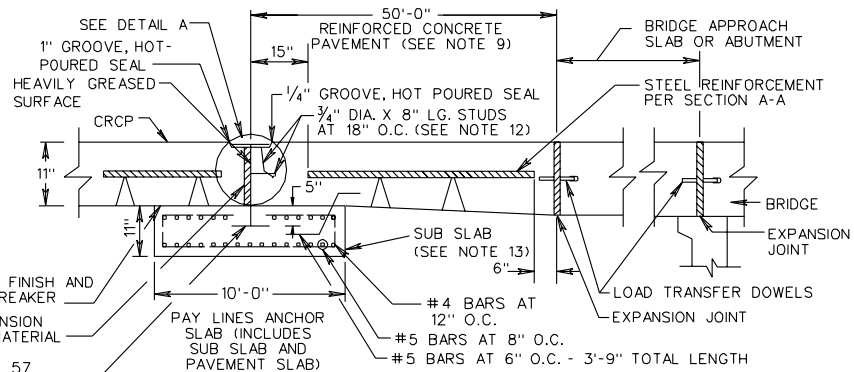

SECTION F-F ANCHOR SLAB TYPE II

SHEET 2 OF 3

SEE SHEET 3 OF 3 FOR NOTES

11" THICK CONTINUOUSLY REINFORCED CONCRETE PAVEMENT  
14 FOOT TRAVEL LANE

REV. 7/03  
301.20

VIRGINIA DEPARTMENT OF TRANSPORTATION

SPECIFICATION REFERENCE

316