

ELECTRIC DETAILS FOR SIGN LIGHTING

SPAN SIGN STRUCTURE

FRONT VIEW

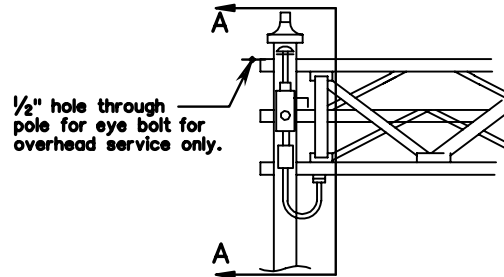

SECTION A-A

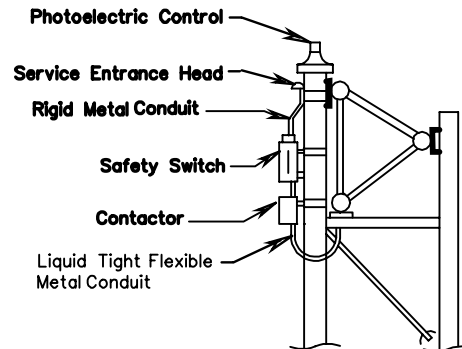

CANTILEVER SIGN STRUCTURE

FRONT VIEW

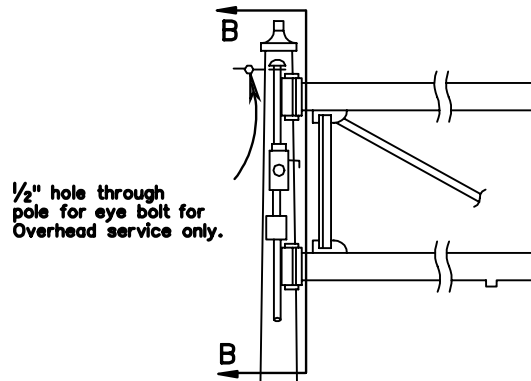

SECTION B-B

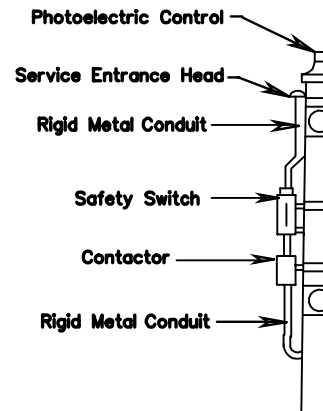

Note:

A safety switch shall be installed on all sign structures requiring electrical power. Electrical service for sign structures not controlled by a control center shall have a photocell and a photocell controlled contactor to control the electrical power to luminaires. The contactor shall be in a NEMA 3R enclosure within 24 inches of the safety switch.

All conduit located in or on overhead sign structure shall be 3/4" minimum.

TYPICAL DETAILS FOR OVERHEAD SIGN STRUCTURES

VIRGINIA DEPARTMENT OF TRANSPORTATION

REV. 7/05
REV. 4/04
REV. 1 / 04

1301.73