

GR-FOA-1

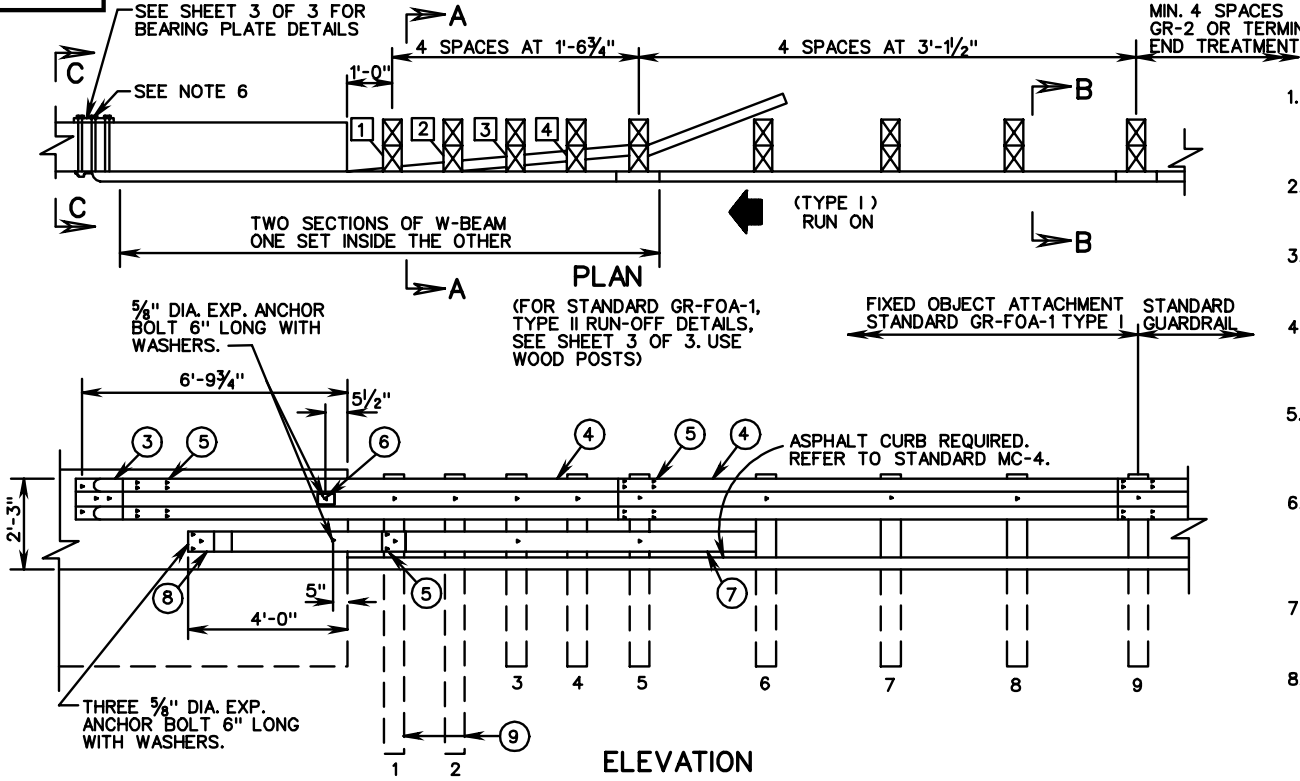

- NOTES:
1. FIXED OBJECTS MAY CONSIST OF BRIDGE RAILS, ABUTMENTS, PIERS, RETAINING WALLS, OR OTHER FLAT SURFACED STRUCTURES WITH VERTICAL FACE.
 2. BRIDGE RAIL ENDS AND BRIDGE PARAPETS MUST BE OF ADEQUATE STRENGTH TO ACCEPT FULL IMPACT LOADING.
 3. GUARDRAIL COMPONENTS SHALL BE IN ACCORDANCE WITH VDOT ROAD AND BRIDGE STANDARDS.
 4. POSTS 1, 2, 3, 4, AND 5 REQUIRE AN ADDITIONAL HOLE TO ATTACH BLOCKS AND/OR RUBRAIL. RUBRAIL IS NOT BOLTED TO POSTS 2 AND 4.
 5. BOTTOM WOOD BLOCKS LOCATED ON POSTS 1 THROUGH 4 ARE CENTER DRILLED AND SECURED WITH 5/8" CARRIAGE BOLTS. (LENGTH AS REQUIRED).
 6. APPROPRIATE LENGTH 7/8" DIAMETER ASTM A325 HEX BOLTS WITH WASHERS MUST BE USED WITH THRU DRILLED HOLES WITH A 5/8" BEARING PLATE ON THE BACK SIDE OF THE BRIDGE PARAPET OR TERMINAL WALL.
 7. DRIVE NAIL WITHIN 2" OF THE TOP OR BOTTOM OF THE BLOCKOUT AFTER 5/8" X 18 BOLT IS INSTALLED.
 8. SEE SHEET 3 OF 3 FOR RUBRAIL BLOCKOUT DETAILS.

NEW BRIDGES - ATTACHMENTS
 ONE WAY TRAFFIC - RUN-ON, 2-GR-FOA-1, TYPE I
 - RUN-OFF, 2-GR-FOA-1, TYPE II
 TWO WAY TRAFFIC - RUN-ON, 4-GR-FOA-1, TYPE I
 EXISTING BRIDGE ATTACHMENTS AS SHOWN ON PLANS.

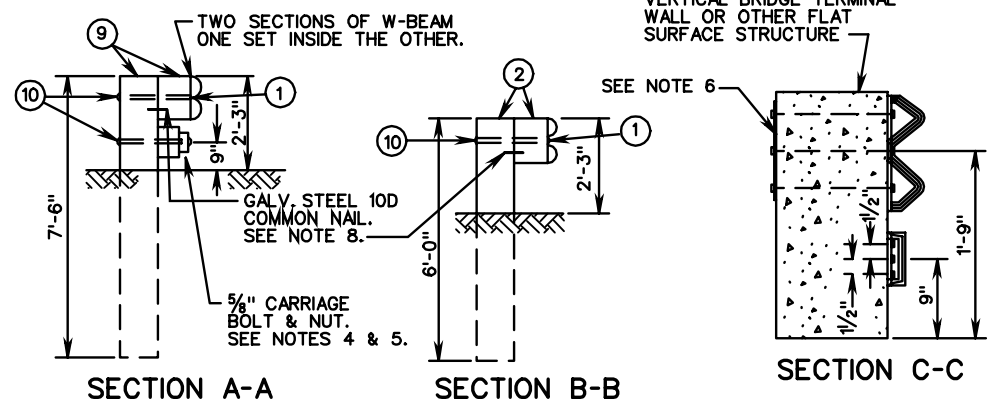

ITEM	MATERIAL/SPECIFICATIONS/NOTES
①	5/8" X 18" LONG. GUARDRAIL BOLT AND RECESSED NUT
②	STANDARD 6" X 8" WOOD POST AND BLOCK
③	STANDARD W-BEAM TERMINAL CONNECTOR
④	STANDARD W-BEAM RAIL
⑤	5/8" X 2" LONG GUARDRAIL BOLT & RECESSED NUT (SEE STANDARD GR-HDW)
⑥	RECTANGULAR PLATE WASHER (SEE STANDARD GR-HDW)
⑦	BENT PLATE RUBRAIL (SEE SHEET 3 OF 3)
⑧	C6 X 8.2 RUBRAIL (SEE SHEET 3 OF 3)
⑨	8" X 8" X 7'-6" LONG WOOD POST & 8" X 8" X 14" LONG TREATED PINE BLOCK OR RECYCLED MATERIAL
⑩	WASHER FOR 5/8" BOLT

REV. 7/01

SHEET 1 OF 3

W-BEAM GUARDRAIL - FIXED OBJECT ATTACHMENT FOR USE BETWEEN VERTICAL FIXED OBJECTS AND GUARDRAIL (WOOD POSTS)

SPECIFICATION REFERENCE

505

501.25

VIRGINIA DEPARTMENT OF TRANSPORTATION