

- NOTES:
1. The minimum slab width is to be 16'.
 2. Slab details are to be in accordance with Standard Plan PR-2 except that expansion, contraction, and longitudinal joints may be eliminated unless required by the Engineer.
 3. Steel fabric slab reinforcement shall consist of members rigidly attached at all joints or points of intersection and shall have an effective weight of not less than 61 Lbs./100 Sq.Ft. Longitudinal members shall be of No. 1 gage wire spaced at 6" o-c. Transverse members shall be of No. 4 gage wire spaced at 12" o-c. Alternate grade 60 No. 4 rebars 12" o-c eachway centered in slab.
 4. Slab is to be constructed on either a straight grade or with vertical curves with a rate of change per foot of less than 2%.
 5. The gradient of slab is to be 12-15%. Ramps constructed in salt water with the possibility of larger boats using the ramp should be designed using the lower end of this range.
 6. All reinforcing steel members are to have a minimum of 3" concrete cover at edges of slab. Mesh reinforcement is to be placed 2" from top of slab.
 7. Final finish of slab is to be obtained by the use of a steel rake (with tines bent away from the direction of pull) drawn transversely to axis of slab (parallel to water line).
 8. Portions of slab which will ultimately be below water level are to be protected during pouring, finishing, and curing by the use of cofferdams, cribs, or other methods meeting the approval of the Engineer.
 9. Class 1 Dry Rip Rap to be in accordance with Road and Bridge Specifications.
 10. Suitable parking areas for vehicles and trailer are to be provided off of ramp.
 11. Ramp should be angled downstream in river situations at the discretion of the Engineer.
 12. On flowing river situations courtesy piers are not desirable, on all other situations a courtesy pier is desirable.
 13. Launch ramps and parking areas should be free of overhead obstructions, especially electrical wires.
 14. These facilities should be handicapped accessible to the top of boat ramp and courtesy pier if provided.
 15. Where wave or tidal action occur, the Rip Rap length above mean high water shall be extended to dissipate water velocities.

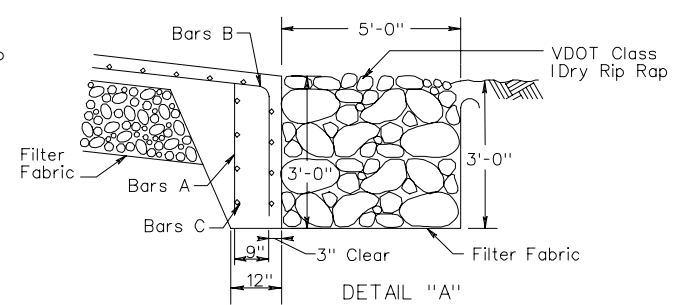
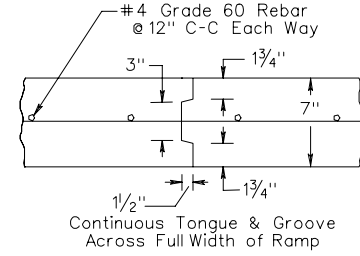
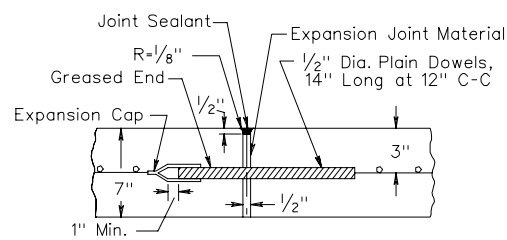
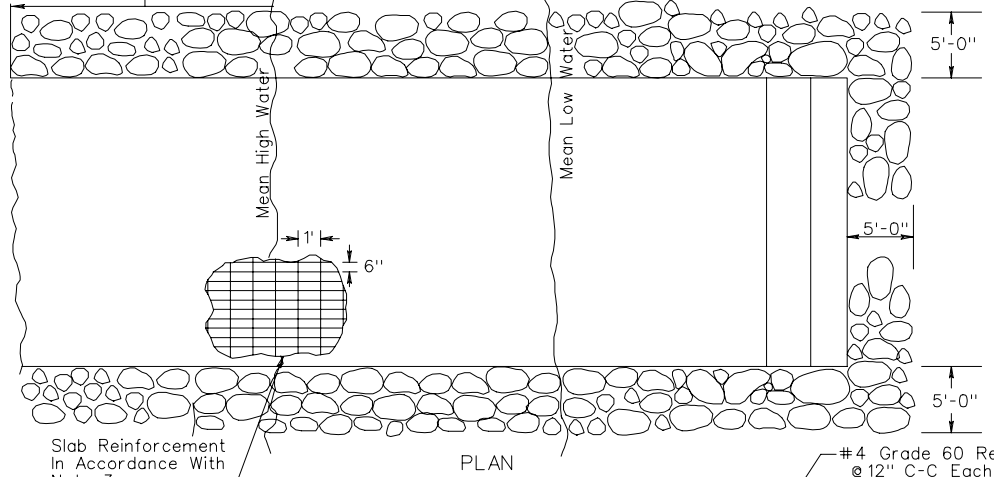
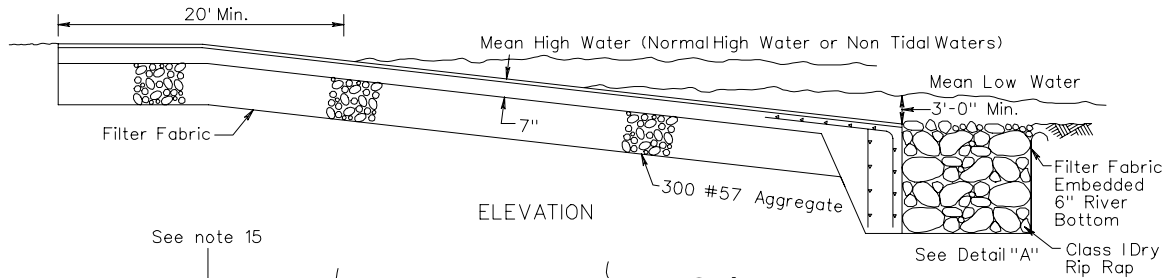

SCHEDULE OF REINFORCING STEEL

BAR	SIZE	NO.	LENGTH	SPACING C-C	
A	#4	*	2'-0"	1'-0"	Straight
B	#4	*	4'-6"	1'-0"	Bent
C	#4	8	* *	9" and as shown	Straight

* No. of bars equals slab width in Feet.
 ** Slab width minus 6"

MINIMUM DESIGN FOR SMALL BOAT LAUNCHING RAMPS AT PUBLIC LANDINGS