

IF NOT OTHERWISE NOTED DIMENSIONS AND DESCRIPTIONS SHOWN ON ONE DRAWING APPLY TO OTHER DETAILS WITH THE SAME POST TYPE.

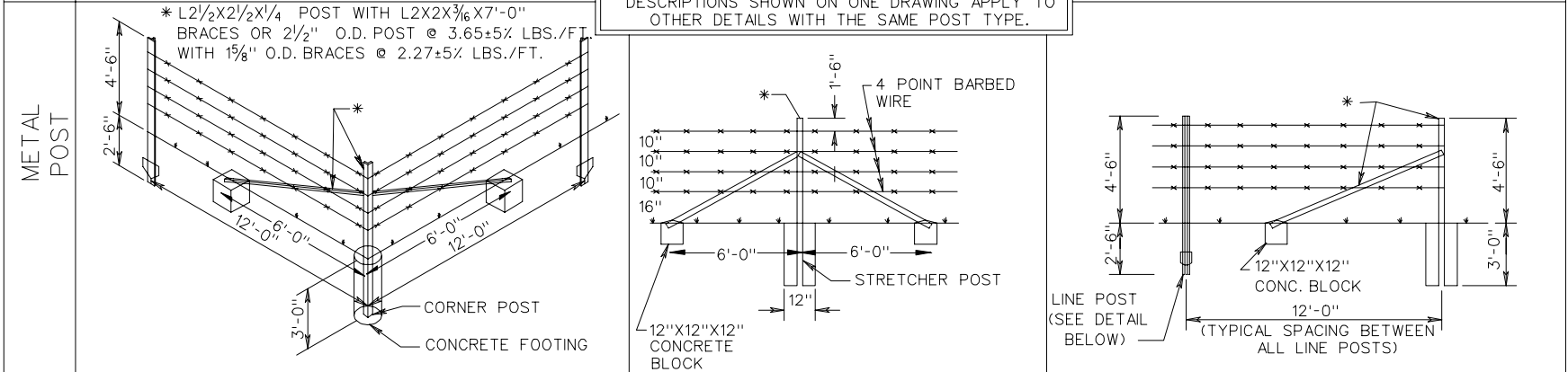



NOTES:
SEE GENERAL NOTES-FENCING FOR ADDITIONAL DETAILS AND INSTRUCTIONS.

LINE POSTS ARE TO BE OF THE TYPES SHOWN OR EQUIVALENT MEETING THE APPROVAL OF THE ENGINEER.

ALL POSTS ARE TO HAVE A MINIMUM WEIGHT OF 1.25 LBS./FT.

A MINIMUM OF FIVE CLAMPS FOR ATTACHING FABRIC TO POST ARE TO BE INCLUDED IN COST OF EACH LINE POST.





FLANGED "U" TYPE "T" TYPE

METAL LINE POST

L2 X 2 X 3/8 TO BE CUT TO FIT AROUND L2 1/2 X 2 1/2 X 1/4 STRETCHER POST.

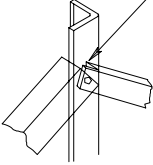
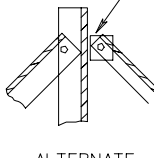
L2 1/2 X 2 1/2 X 1/4, 2" LONG BRACKET BOLTED TO STRETCHER POST

METHOD OF ATTACHING ANGLE BRACES TO STRETCHER POSTS ALTERNATE

FOR USE IN LIEU OF SETTING POSTS IN CONCRETE. DEVICES SHOWN ARE REPRESENTATIONAL ONLY. SEE GENERAL NOTES.

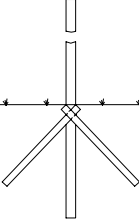
ALTERNATE ANCHOR DEVICES

SPECIFICATION REFERENCE
242 507 236

STANDARD FENCE BARBED WIRE

VIRGINIA DEPARTMENT OF TRANSPORTATION