

- NOTES:
1. FIXED OBJECTS MAY CONSIST OF SAFETY SHAPED BRIDGE PARAPETS OR CONCRETE BARRIERS.
 2. BRIDGE RAIL ENDS AND BRIDGE PARAPETS MUST BE OF ADEQUATE STRENGTH TO ACCEPT FULL IMPACT LOADING.
 3. GUARDRAIL COMPONENTS SHALL BE IN ACCORDANCE WITH VDOT ROAD AND BRIDGE STANDARDS.
 4. POSTS 1, 2, 3, 4, AND 5 REQUIRE AN ADDITIONAL HOLE TO ATTACH LOWER BLOCKS AND/OR RUBRAIL. RUBRAIL IS NOT BOLTED TO POSTS 2 AND 4.
 5. BOTTOM WOOD BLOCKS LOCATED ON POSTS 1 THROUGH 4 ARE CENTER DRILLED AND SECURED WITH 5/8" CARRIAGE BOLTS. (LENGTH AS REQUIRED).
 6. RUBRAIL MUST BE TWISTED 35° BETWEEN SECTION C-C AND D-D. SHOP FABRICATION MAY BE REQUIRED. RIGHT HAND AND LEFT HAND TWISTS WILL BE NECESSARY.
 7. APPROPRIATE LENGTH 7/8" ASTM A325 HEX BOLTS WITH WASHERS MUST BE USED WITH THRU DRILLED HOLES WITH A 5/8" BEARING PLATE ON THE BACK SIDE OF THE BRIDGE PARAPET OR CONCRETE BARRIER.
 8. DRIVE NAIL WITHIN 2" OF THE TOP OR BOTTOM OF BLOCKOUT AFTER 5/8" X 18 BOLT IS INSTALLED.
 9. SEE SHEET 3 OF 3 FOR RUBRAIL BLOCKOUT DETAILS.

NOTE:
RUBRAIL MUST BE TWISTED 35° BETWEEN SECTION C-C AND D-D. SHOP FABRICATION MAY BE REQUIRED. RIGHT HAND AND LEFT HAND TWISTS WILL BE NECESSARY.

NEW BRIDGE - ATTACHMENTS
ONE-WAY TRAFFIC-RUN-ON, 2-GR-FOA-2, TYPE I
-RUN-OFF, 2-GR-FOA-2, TYPE II
TWO-WAY TRAFFIC-RUN-ON, 4-GR-FOA-2, TYPE I
EXISTING BRIDGE ATTACHMENTS AS SHOWN ON PLANS.

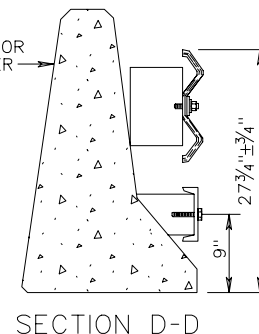
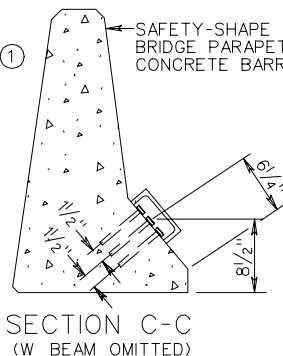
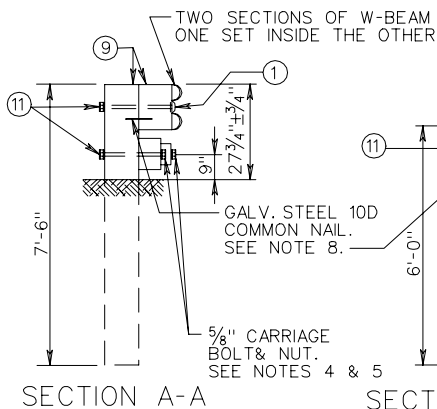

ITEM	MATERIAL/SPECIFICATIONS/NOTES
①	5/8" X 18" LG. GUARDRAIL BOLT AND RECESSED NUT.
②	STANDARD 6" X 8" WOOD POST AND BLOCK.
③	STANDARD W-BEAM TERMINAL CONNECTOR
④	STANDARD W-BEAM RAIL
⑤	5/8" X 2" LONG GUARDRAIL BOLT AND RECESSED NUT (SEE STANDARD GR-HDW)
⑥	RECTANGULAR PLATE WASHER (SEE STANDARD GR-HDW)
⑦	BENT PLATE RUBRAIL (SEE SHEET 3 OF 3)
⑧	C6 X 8.2 RUBRAIL (SEE SHEET 3 OF 3)
⑨	8" X 8" X 7'-6" LONG WOOD POST AND 8" X 8" X 14" LONG TREATED PINE BLOCK OR RECYCLED MATERIAL
⑩	WOOD BLOCKOUT FOR RUBRAIL (SEE SHEET 3 OF 3)
⑪	WASHER FOR 5/8" BOLT

SPECIFICATION REFERENCE
506

W-BEAM GUARDRAIL - FIXED OBJECT ATTACHMENT FOR USE BETWEEN SAFETY SHAPE AND GUARDRAIL (WOOD POSTS)