

GR-2,2A

BLOCKOUT FOR CONCRETE POST TO BE CUT TO FIT POST SHAPE TO PREVENT BLOCKOUT FROM ROTATING.

DIMENSIONS SHOWN IN PARENTHESIS INDICATE ACCEPTABLE TOLERANCES.

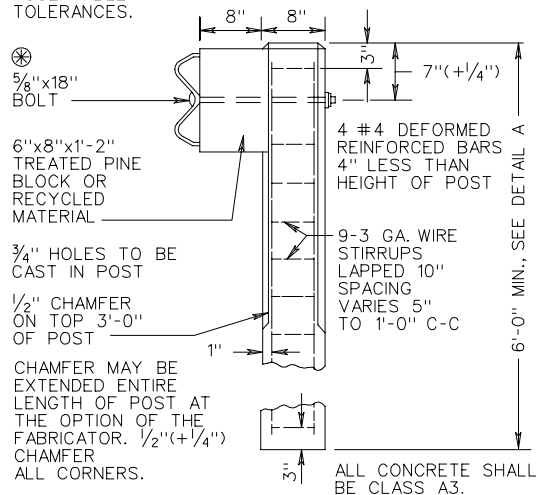

CONCRETE POST

POST MAY BE HOT ROLLED OR WELDED.

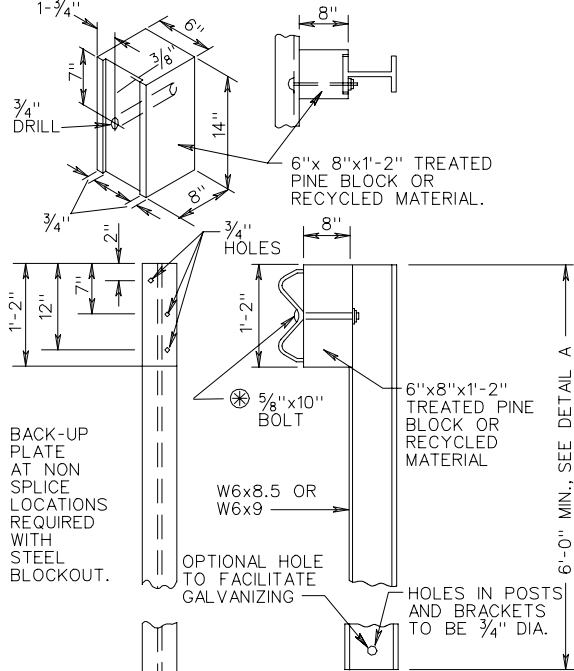

STEEL POST

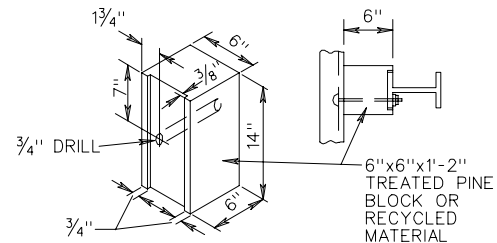

BLOCKOUT FOR MAINTENANCE REPAIR ONLY

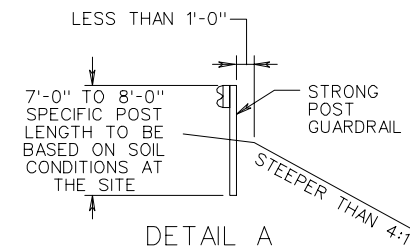

GUARDRAIL INSTALLATION SITES REQUIRING LONGER GUARDRAIL POSTS

NOTES:

1. ALL BOLTS, NUTS, WASHERS, AND OTHER STEEL ITEMS ARE TO BE GALVANIZED.
 2. ALTERNATE TYPE POSTS AND BLOCKOUT MAY BE INTERCHANGED ON ANY ONE PROJECT WITH THE RESTRICTION THAT THE SAME TYPE OF POST AND BLOCKOUT MUST BE USED IN ANY SINGLE RUN OF GUARDRAIL.
 3. FOR DETAILS OF GUARDRAIL ELEMENT SPLICE JOINT, HARDWARE, ETC. SEE SHEET NOS. 501.01 AND 501.02.
 4. THE GUARDRAIL AND MEDIAN BARRIER COMPONENTS DEPICTED IN A.R.T.B.A. TECHNICAL BULLETIN NUMBER 268B MAY BE SUBSTITUTED IF INTERCHANGEABLE WITH THE STANDARDS FOR GUARDRAIL (GR) OR MEDIAN BARRIER (MB) AND APPROVED BY THE ENGINEER.
 5. DRIVE NAIL ON BOTH SIDES WITHIN 2" OF THE TOP OR BOTTOM OF BLOCKOUT AFTER 5/8" x 18" BOLT IS INSTALLED.
- ⊗ STANDARD WASHER TO BE USED ON LAST 50' OF RUN-OFF END ONLY UNLESS A STANDARD GR-11 RUN-OFF TERMINAL TREATMENT IS USED.

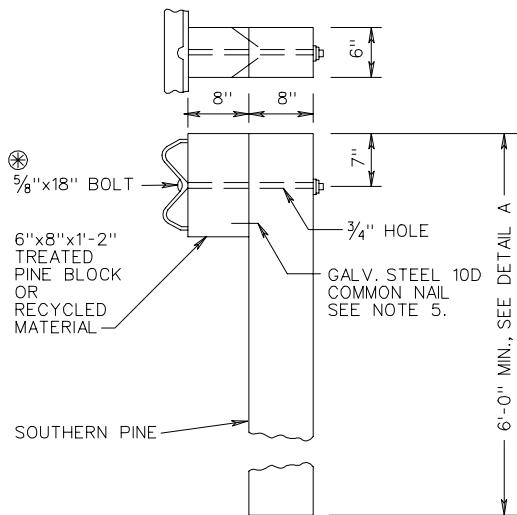

6x8 WOOD POST

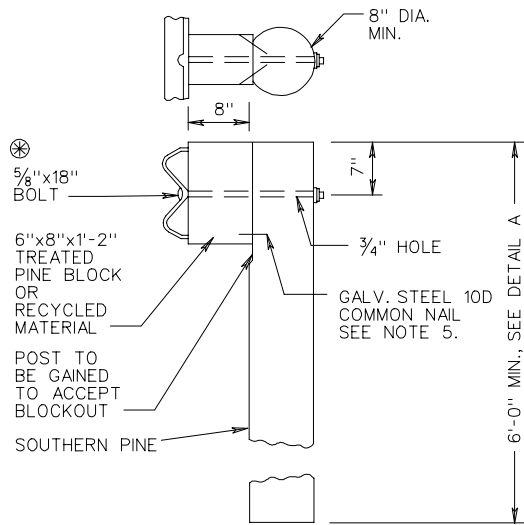

ROUND WOOD POST

SHEET 2 OF 2

STANDARD BLOCKED-OUT W BEAM GUARDRAIL (STRONG POST SYSTEM)
POST AND BLOCKOUT DETAILS

SPECIFICATION REFERENCE

221
236
505

REV. 9/06
501.05

VIRGINIA DEPARTMENT OF TRANSPORTATION