

PLAN VIEW

NOTES:  
 FOR 36' PAVEMENT, USE SINGLE 12' LANES WITH 2 CONSTRUCTION JOINTS, OR 12' AND 24' LANES WITH ONE GROOVE AND ONE CONSTRUCTION JOINT.  
 TRANSVERSE WIRES DO NOT EXTEND THROUGH LONGITUDINAL JOINTS.  
 TIE BARS AND DOWEL BARS ARE TO BE AS NEAR MIDPOINT OF PAVEMENT DEPTH AS FEASIBLE.  
 \* THE DOUBLE LAP REQUIREMENT (36") AND OR EXTRA BAR METHOD APPLIES ONLY TO LAPS FALLING WITHIN AN AREA 10' BEYOND THE CONSTRUCTION JOINT.  
 #5 X 2'-6" DEFORMED TIE BARS AT 30" O.C. MAY BE USED IN LIEU OF HOOK BOLTS WHERE SHOWN HEREON.

SMOOTH SURFACE TO BE STEEL TROWELED 8" IN FROM THE EDGE OF PAVEMENT EVERY 500 FEET, AND STATION NUMBER STAMPED INTO IT. THE DATE IS TO BE SHOWN IN A SIMILAR MANNER AT THE BEGINNING OF EACH DAYS POUR.

BOTH OUTSIDE EDGES OF DIVIDED HIGHWAY TO BE STAMPED. ONE EDGE OF UNDIVIDED HIGHWAYS WHERE FEASIBLE. (TRAVEL LANE)

SHEETS TO BE SECURELY FASTENED TO PREVENT SEPARATION DURING CONCRETE PLACEMENT.

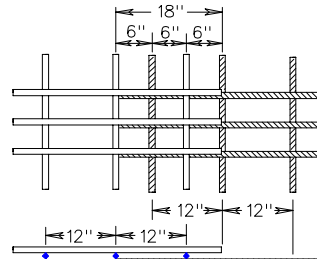

END LAP DETAIL

1 3/4" MIN. MALLEABLE IRON OR STEEL SLEEVE, THREADED ENTIRE LENGTH, ON INSIDE TO RECEIVE 5/8" BOLT.

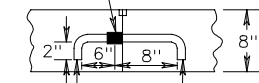

5/16" EFFECTIVE DIA. X 6" HOOK BOLT.

5/16" EFFECTIVE DIA. X 8" HOOK BOLT.

HOOK BOLT DETAIL

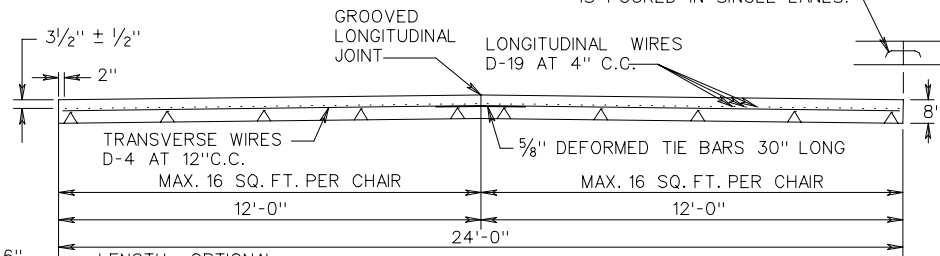

TRANSVERSE SECTION

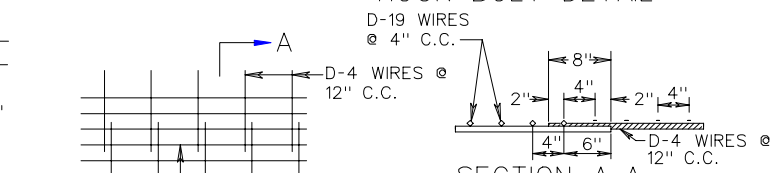

EDGE LAP DETAIL

SECTION A-A

SHEETS TO BE SECURELY FASTENED TO PREVENT SEPARATION DURING CONCRETE PLACEMENT.

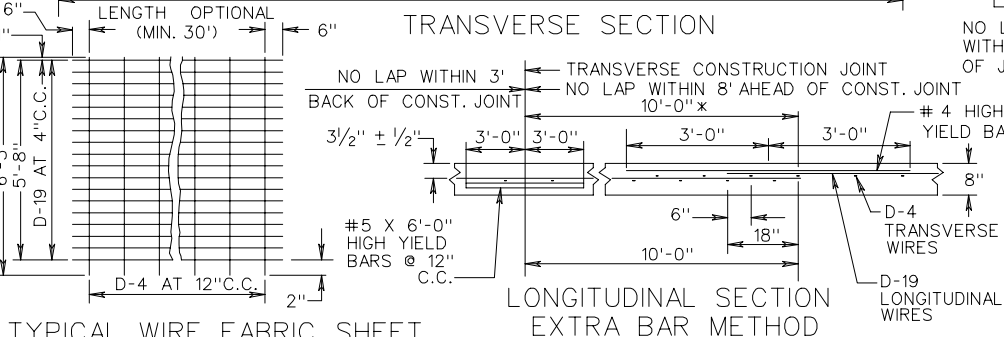

LONGITUDINAL SECTION EXTRA BAR METHOD

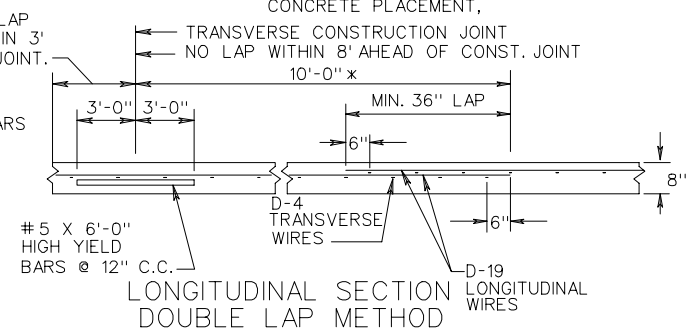

LONGITUDINAL SECTION DOUBLE LAP METHOD

TYPICAL WIRE FABRIC SHEET

8" THICK CONTINUOUSLY REINFORCED CONCRETE PAVEMENT  
 (WIRE MESH REINFORCEMENT)