

MC-3

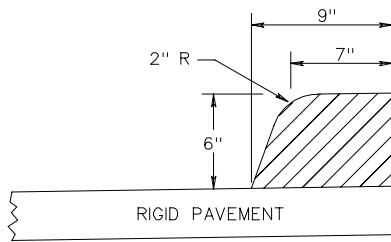

ASPHALT CURB

MC-3

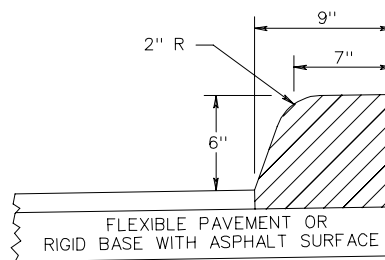

ASPHALT CURB

MC-3A

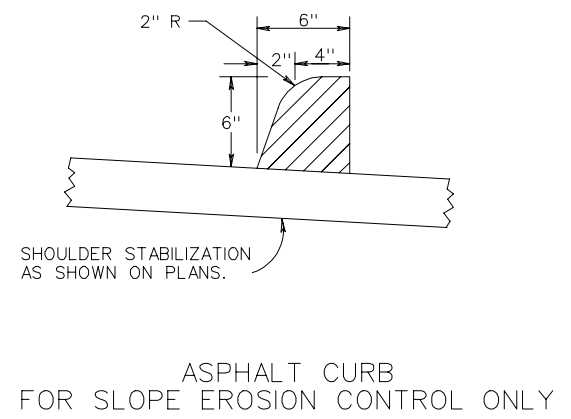

ASPHALT CURB FOR SLOPE EROSION CONTROL ONLY

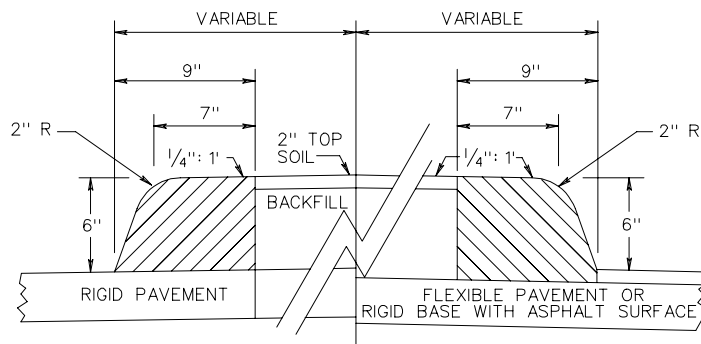

ASPHALT MEDIAN

MC-3 AND MC-3A IS TO BE USED ON ROADWAYS MEETING THE REQUIREMENTS FOR CG-6 AS SHOWN IN APPENDIX A OF THE VDOT ROAD DESIGN MANUAL.

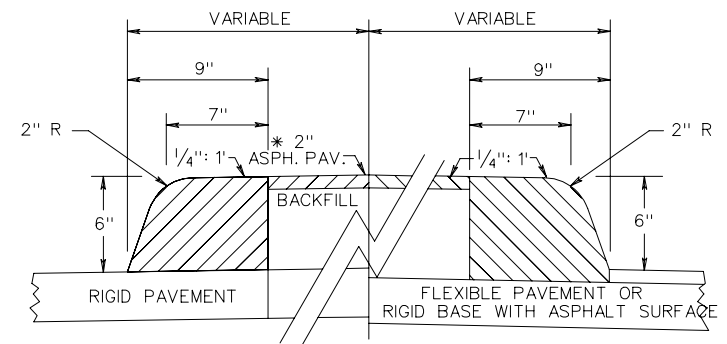

ASPHALT MEDIAN

\* ASPHALT TOP FOR MEDIAN TO BE SAME MIX AS CURB.

SPECIFICATION REFERENCE
502

# ASPHALT CONCRETE CURB AND MEDIAN FOR TEMPORARY OR PERMANENT INSTALLATION

VIRGINIA DEPARTMENT OF TRANSPORTATION

REV. 9/06  
201.05