

- * 30" PIPE = 2 BARS - 10.46 LBS. REINFORCING STEEL
- 24" PIPE = 4 BARS - 17.59 LBS. REINFORCING STEEL
- 21" PIPE = 5 BARS - 21.15 LBS. REINFORCING STEEL

SCHEDULE OF REINFORCING STEEL						
MARK	NO.	LENGTH		SIZE	SPACING C-C	SHAPE
		2:1	1 1/2:1			
F	5	1'-0"	1'-0"	4	4"	STRAIGHT
G	*	5'-4"	5'-4"	4	4"	BENT
L	22	2'-0"		3	12"	BENT
L	16		2'-0"	3	12"	BENT

APPROXIMATE QUANTITIES			
PIPE SPILLOUT	SLOPE	CLASS A3 CONCRETE	REINFORCING STEEL
		CU. YARDS.	LBS.
PIPE SPILLOUT	2:1	± 1.351	*
	1 1/2:1	± 1.037	*

‡ QUANTITIES BASED ON 30" PIPE.

NOTE: DOWELS TO BE LOCATED AT ALL REQUIRED JOINTS.

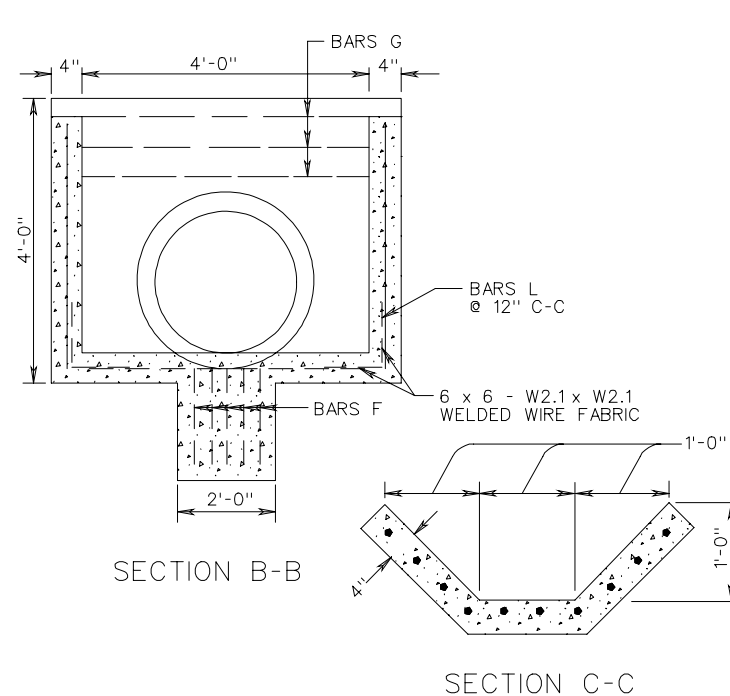
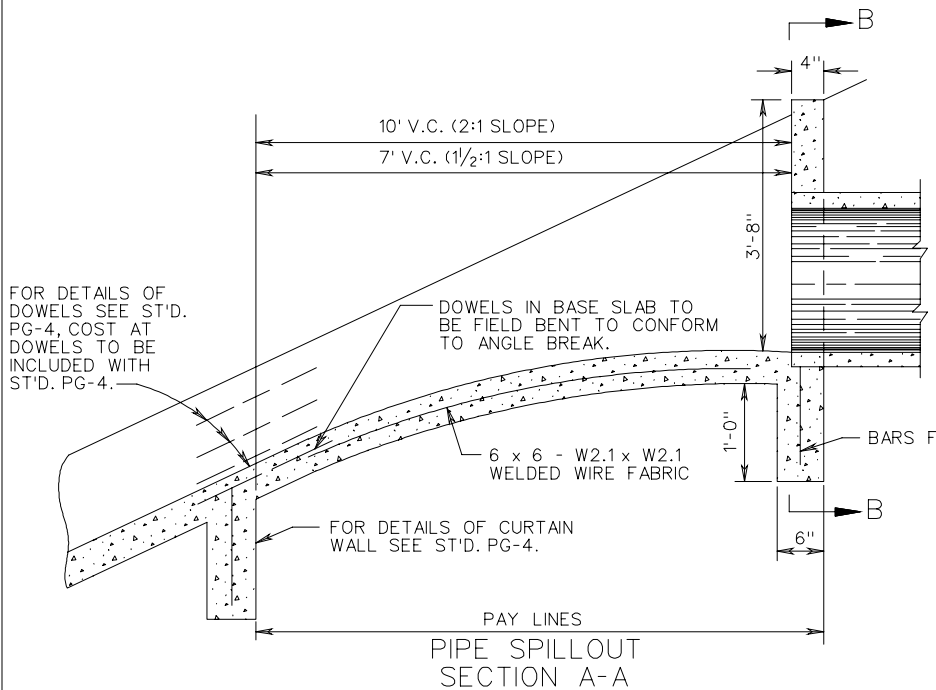

STANDARD PIPE SPILLOUT FOR 21" - 30" PIPE CULVERTS

VIRGINIA DEPARTMENT OF TRANSPORTATION

SPECIFICATION REFERENCE

302