

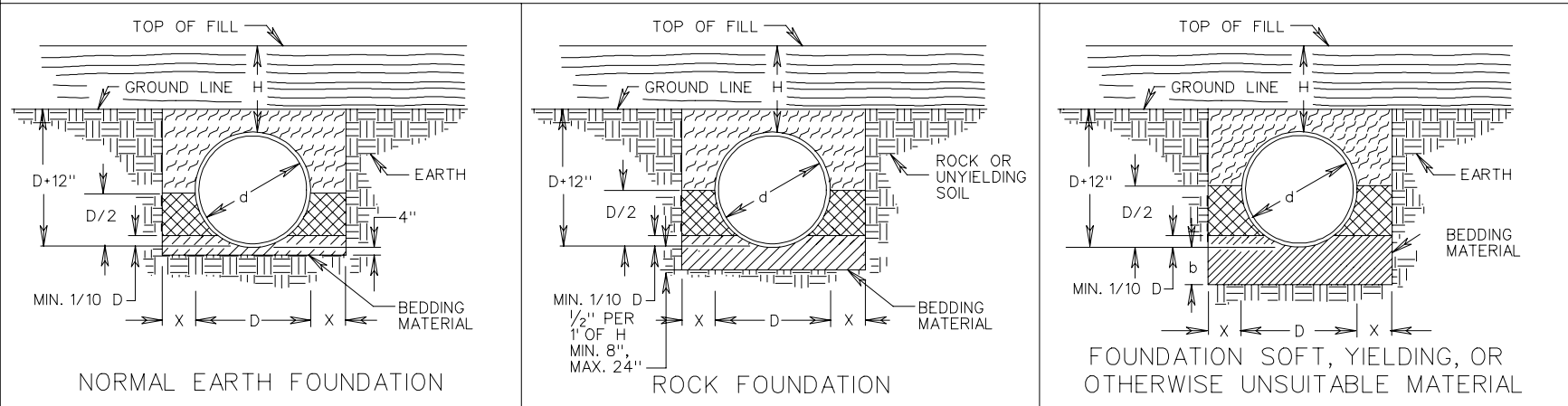

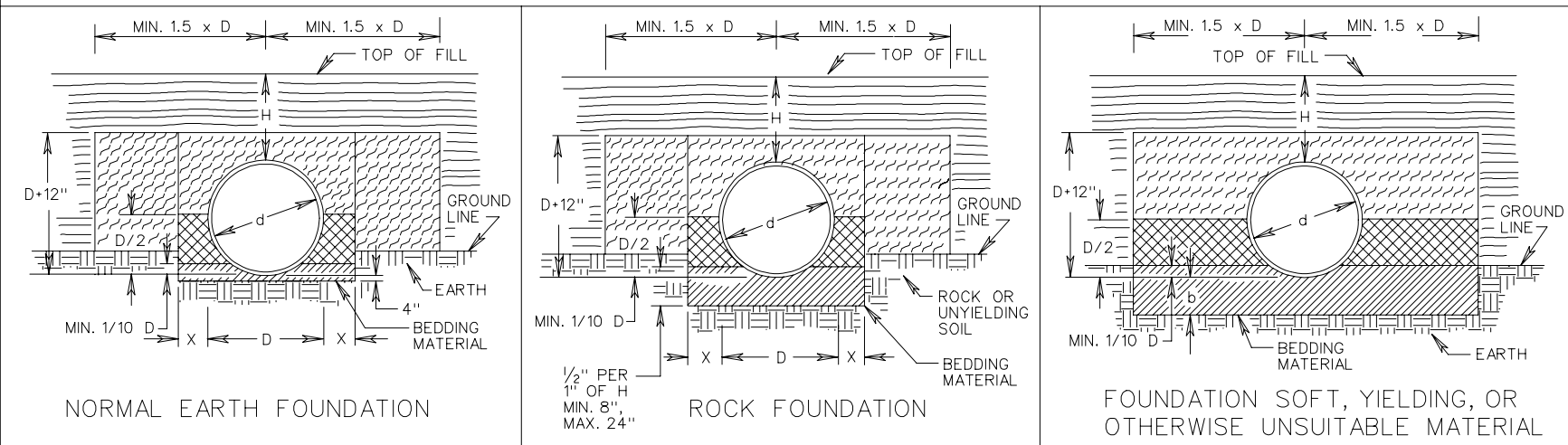

NO PROJECTION OF PIPE ABOVE GROUND LINE



PIPE PROJECTION ABOVE GROUND LINE



-  BEDDING MATERIAL IN ACCORDANCE WITH SECTION 302 OF THE ROAD AND BRIDGE SPECIFICATIONS.
-  CLASS I BACKFILL MATERIAL IN ACCORDANCE WITH SECTION 302 OF THE ROAD AND BRIDGE SPECIFICATIONS.
-  REGULAR BACKFILL MATERIAL IN ACCORDANCE WITH SECTION 302 OF THE ROAD AND BRIDGE SPECIFICATIONS.
-  EMBANKMENT

NOTES:

FOR PLASTIC PIPE, THE LIMITS OF THE CLASS I BACKFILL MATERIAL SHALL BE EXTENDED TO 12" ABOVE THE TOP OF THE PIPE.

FOR GENERAL NOTES ON PIPE BEDDING, SEE INSTALLATION OF PIPE CULVERTS AND STORM SEWERS GENERAL NOTES ON SHEET 107.00.

<p>SPECIFICATION REFERENCE</p> <p>302</p> <p>303</p>	<p>INSTALLATION OF PIPE CULVERTS AND STORM SEWERS</p> <p>CIRCULAR PIPE BEDDING AND BACKFILL - METHOD "A"</p> <p>VIRGINIA DEPARTMENT OF TRANSPORTATION</p>	<p>REV. 7/05</p> <p>107.01</p>
--	---	--------------------------------