

NOTES:
 THE LETTERS V.D.O.T. ARE OPTIONAL,
 IF USED THE LETTERS ARE TO BE
 CAST IN THE DEPRESSION IN TOP OF
 COVER 1" WIDE AND RAISED $\frac{3}{8}$ " HIGH
 AS SHOWN.

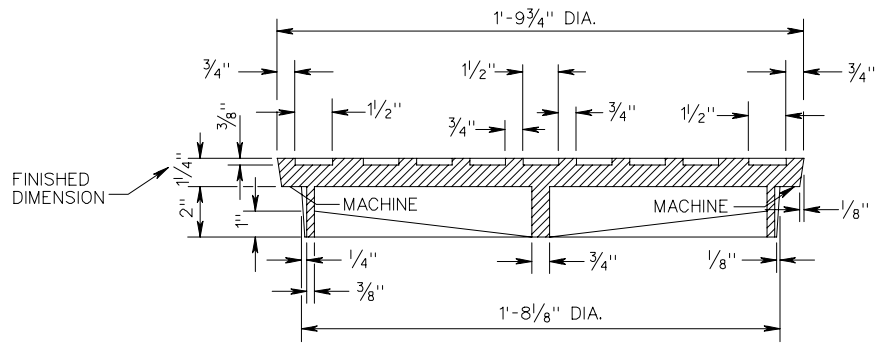

SECTION A-A

LETTERING
 OPTIONAL

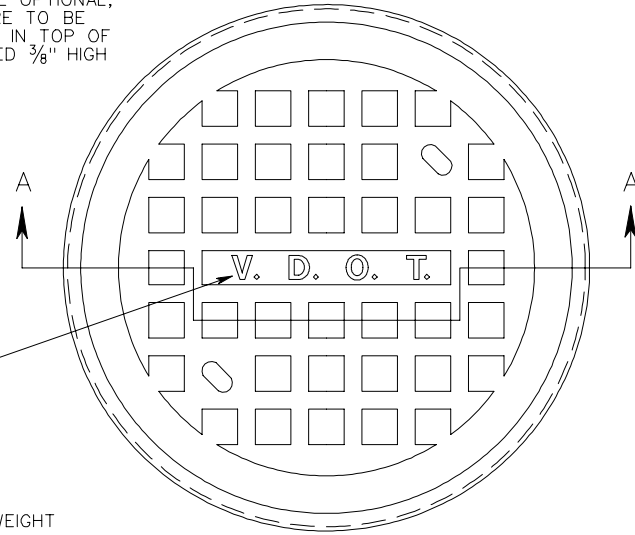

TOP

APPROXIMATE WEIGHT
 CAST IRON
 COVER 137 ± 7 LBS.
 FRAME 235 ± 12 LBS.

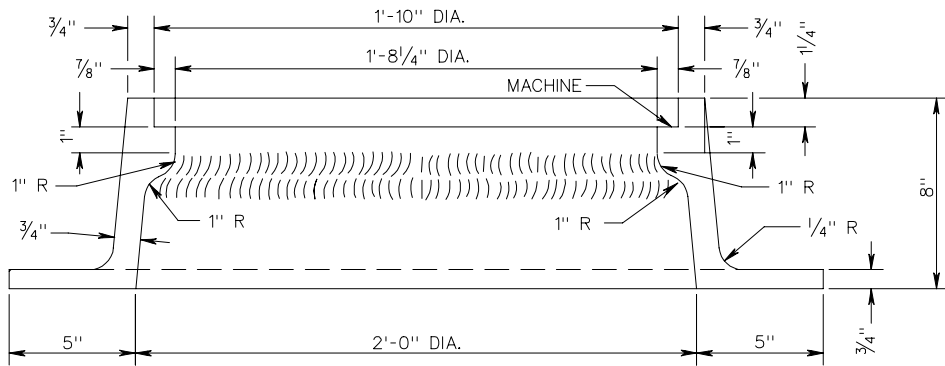

FRAME SECTION AT MID POINT

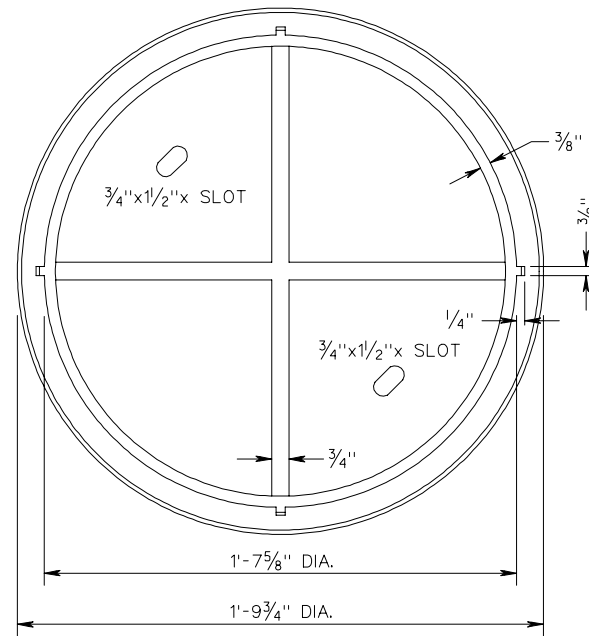

BOTTOM

STANDARD MANHOLE FRAME AND COVER

VIRGINIA DEPARTMENT OF TRANSPORTATION

SPECIFICATION
 REFERENCE

224
 302