

TABLE OF QUANTITIES

DI-2A,2B,2C

| TYPE | L | REINFORCING STEEL | | | | | | | | | | | | | | | |
|-------|-------|-------------------|----------|-------|-----------|--------|-----------|-------|----------------|----------------|-----------|-------|-----------|--------|-----------|-------|-----------|
| | | CONCRETE | BARS A | | BARS A-1 | | BARS B | | BARS B-1 | | BARS C | | BARS E | | BARS F | | WEIGHT |
| | | Ft. | Cu. Yds. | No. | Lin. Ft.* | No. | Lin. Ft.* | No. | Lin. Ft.* | No. | Lin. Ft.* | No. | Lin. Ft.* | No. | Lin. Ft.* | No. | Lin. Ft.* |
| DI-2A | 2'-2" | 1.71 | 4 | 3'-2" | 5 | 3'-2" | 4 | 3'-6" | - | - | 5 | 2'-0" | - | - | - | 1'-6" | 55 |
| DI-2B | 4' | 1.95 | 4 | 3'-2" | 5 | 5'-0" | 4 | 3'-6" | 3 | 4'-3" to 4'-6" | 5 | 2'-0" | 3 | 2'-0" | 3 | 1'-6" | 84 |
| | 6' | 2.23 | 4 | 3'-2" | 5 | 7'-0" | 4 | 3'-6" | 7 | 4'-3" to 4'-6" | 5 | 2'-0" | 3 | 4'-0" | 3 | 1'-6" | 119 |
| | 8' | 2.51 | 4 | 3'-2" | 5 | 9'-0" | 4 | 3'-6" | 11 | 4'-3" to 4'-6" | 5 | 2'-0" | 3 | 6'-0" | 3 | 1'-6" | 154 |
| | 10' | 2.79 | 4 | 3'-2" | 5 | 11'-0" | 4 | 3'-6" | 15 | 4'-3" to 4'-6" | 5 | 2'-0" | 3 | 8'-0" | 3 | 1'-6" | 189 |
| | 12' | 3.05 | 4 | 3'-2" | 5 | 13'-0" | 4 | 3'-6" | 19 | 4'-3" to 4'-6" | 5 | 2'-0" | 3 | 10'-0" | 3 | 1'-6" | 224 |
| | 14' | 3.34 | 4 | 3'-2" | 5 | 15'-0" | 4 | 3'-6" | 23 | 4'-3" to 4'-6" | 5 | 2'-0" | 3 | 12'-0" | 3 | 1'-6" | 259 |
| | 16' | 3.61 | 4 | 3'-2" | 5 | 17'-0" | 4 | 3'-6" | 27 | 4'-3" to 4'-6" | 5 | 2'-0" | 3 | 14'-0" | 3 | 1'-6" | 294 |
| | 18' | 3.89 | 4 | 3'-2" | 5 | 19'-0" | 4 | 3'-6" | 31 | 4'-3" to 4'-6" | 5 | 2'-0" | 3 | 16'-0" | 3 | 1'-6" | 329 |
| DI-2C | 20' | 4.17 | 4 | 3'-2" | 5 | 21'-0" | 4 | 3'-6" | 35 | 4'-3" to 4'-6" | 5 | 2'-0" | 3 | 18'-0" | 3 | 1'-6" | 364 |
| | 6' | 2.24 | 4 | 3'-2" | 5 | 7'-0" | 4 | 3'-6" | 6 | 4'-3" to 4'-6" | 5 | 2'-0" | 6 | 2'-1" | 6 | 1'-6" | 115 |
| | 8' | 2.55 | 4 | 3'-2" | 5 | 9'-0" | 4 | 3'-6" | 10 | 4'-3" to 4'-6" | 5 | 2'-0" | 6 | 3'-1" | 6 | 1'-6" | 150 |
| | 10' | 2.82 | 4 | 3'-2" | 5 | 11'-0" | 4 | 3'-6" | 14 | 4'-3" to 4'-6" | 5 | 2'-0" | 6 | 4'-1" | 6 | 1'-6" | 185 |
| | 12' | 3.09 | 4 | 3'-2" | 5 | 13'-0" | 4 | 3'-6" | 18 | 4'-3" to 4'-6" | 5 | 2'-0" | 6 | 5'-1" | 6 | 1'-6" | 220 |
| | 14' | 3.37 | 4 | 3'-2" | 5 | 15'-0" | 4 | 3'-6" | 22 | 4'-3" to 4'-6" | 5 | 2'-0" | 6 | 6'-1" | 6 | 1'-6" | 255 |
| | 16' | 3.65 | 4 | 3'-2" | 5 | 17'-0" | 4 | 3'-6" | 26 | 4'-3" to 4'-6" | 5 | 2'-0" | 6 | 7'-1" | 6 | 1'-6" | 290 |
| | 18' | 3.93 | 4 | 3'-2" | 5 | 19'-0" | 4 | 3'-6" | 30 | 4'-3" to 4'-6" | 5 | 2'-0" | 6 | 8'-1" | 6 | 1'-6" | 325 |
| 20' | 4.20 | 4 | 3'-2" | 5 | 21'-0" | 4 | 3'-6" | 34 | 4'-3" to 4'-6" | 5 | 2'-0" | 6 | 9'-1" | 6 | 1'-6" | 360 | |

NOTES

- DEPTH OF INLET (H) TO BE SHOWN ON PLANS.
- THE "H" DIMENSION SHOWN ON THE STANDARDS AND SPECIFIED ON THE PLANS WILL BE MEASURED FROM THE INVERT OF THE OUTFALL PIPE TO THE TOP OF THE STRUCTURE. PLAN "H" DIMENSIONS ARE APPROXIMATE ONLY FOR ESTIMATING PURPOSES AND THE ACTUAL DIMENSIONS SHALL BE DETERMINED BY THE CONTRACTOR FROM FIELD CONDITIONS.
- WHEN SPECIFIED ON THE PLANS THE INVERT IS TO BE SHAPED IN ACCORDANCE WITH STANDARD IS-1. THE COST OF FURNISHING AND PLACING ALL MATERIALS INCIDENTAL TO THE SHAPING IS TO BE INCLUDED IN THE BID PRICE FOR THE STRUCTURE.
- IN THE EVENT THE INVERT OF THE OUTFALL PIPE IS HIGHER THAN THE BOTTOM OF THE STRUCTURE, THE INVERT OF THE STRUCTURE SHALL BE SHAPED WITH CEMENT MORTAR TO PREVENT STANDING OR PONDING OF WATER IN THE STRUCTURE. THE COST OF FURNISHING AND PLACING ALL MATERIALS INCIDENTAL TO THE SHAPING IS TO BE INCLUDED IN THE BID PRICE FOR THE STRUCTURE.
- STEPS ARE TO BE PROVIDED WHEN H IS 4'-0" OR GREATER. FOR DETAILS SEE STANDARD ST-1.
- THIS ITEM MAY BE PRECAST OR CAST-IN-PLACE.
- # 4 X 8" SMOOTH DOWELS AT APPROXIMATELY 12" C-C TO BE PLACED IN ALL AREAS ADJACENT TO ABUTTING CONCRETE TO PREVENT SETTLEMENT.
- 3" DIAMETER WEEP HOLE TO BE LOCATED TO DRAIN SUBBASE MATERIAL. WEEP HOLE WITH 12"X12" PLASTIC HARDWARE CLOTH 1/4" MESH OR GALVANIZED STEEL WIRE, MINIMUM WIRE DIAMETER 0.03", NUMBER 4 MESH HARDWARE CLOTH ANCHORED FIRMLY TO THE OUTSIDE OF THE STRUCTURE.
- ALL REINFORCING STEEL SHALL HAVE A MINIMUM COVER OF 2".
- ALL REINFORCING STEEL TO BE CUT CLEAR OF ALL OPENINGS BY 2".
- CAST-IN PLACE CONCRETE IS TO BE CLASS A3 (3000 PSI). PRECAST CONCRETE IS TO BE 4000 PSI.
- LENGTH OF SLOT (L) WILL, IN EVERY CASE, BE SHOWN ON PLANS.
- THIS STANDARD IS INTENDED FOR USE IN CURB AND GUTTER SITUATIONS ONLY.
- STANDARD INLETS MAY BE CONSTRUCTED WITH CONCRETE BLOCKS IN ACCORDANCE WITH THE DETAILS SHOWN ON STANDARD DRAWING DI-MB.
- THIS AREA MAY BE EARTHEN, IN WHICH CASE THE EXPANSION JOINTS WILL APPLY ONLY TO CURB AND GUTTER.
- CONCRETE QUANTITIES SHOWN ARE FOR DEPTH (H) OF 5'-2" WITHOUT PIPES. THE AMOUNT DISPLACED BY PIPES MUST BE DEDUCTED TO OBTAIN TRU QUANTITIES, FOR INLETS OF DIFFERENT DEPTHS ADD OR SUBTRACT 0.28 CUBIC YARDS OF CONCRETE FOR EACH FOOT.
- LENGTH OF ANGLE IRON AS SHOWN ON SHEET 1 OF 2 IS TO BE L + 16" AT 4.10 LBS./FT..
- * DENOTES LENGTH OF ONE (1) BAR.
- ALL REINFORCING BARS TO BE #5.
- GRATE TO BE INSTALLED SO SLOTS WILL DIRECT WATER TOWARD THE INLET THROAT.
- MINIMUM HEIGHT = PIPE DIA. + 2'-6" WHEN PIPES ARE LOCATED UNDER EXTENDED SLOT OF INLET.

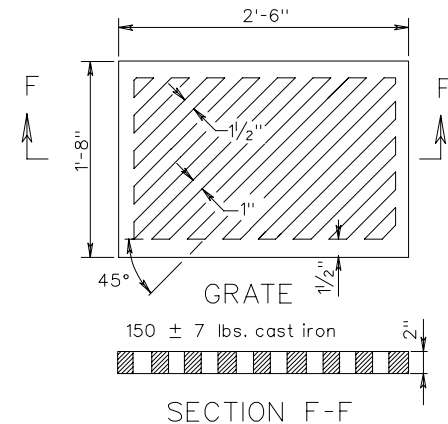

SPECIFICATION REFERENCE

233
302

STANDARD CURB DROP INLET
12"-24" PIPE: MAXIMUM DEPTH (H)=9'

VIRGINIA DEPARTMENT OF TRANSPORTATION

Sheet 2 of 2

104.04