

B-1,B-2

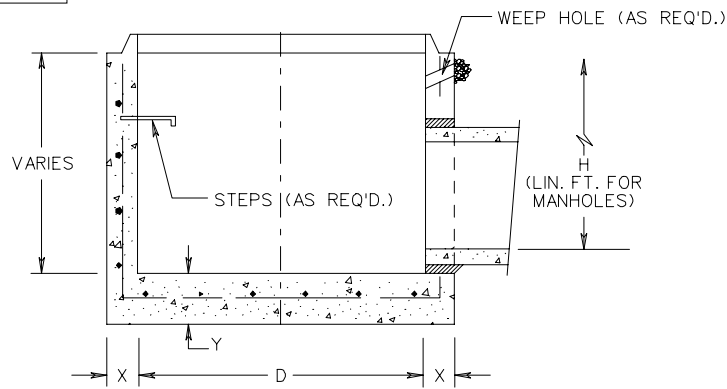

B-1

MONOLITHIC

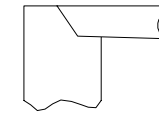
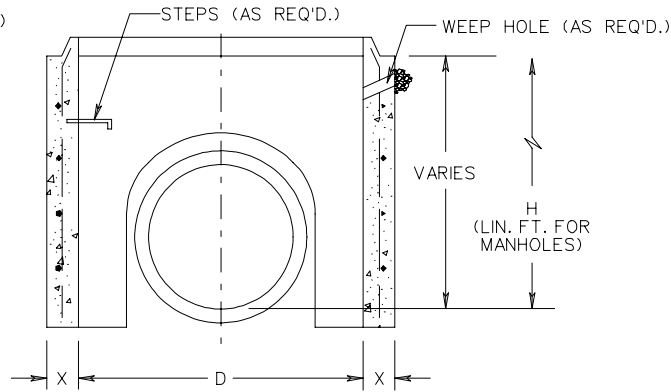

ALTERNATE JOINT
DETAIL

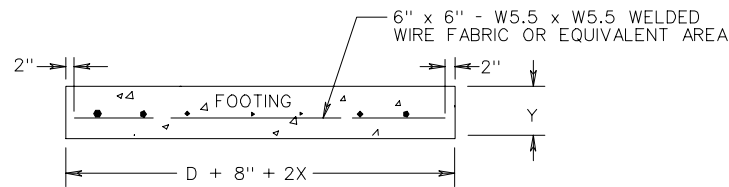

B-2

DOGHOUSE WITH FOOTING

NOTES:

1. SEE GENERAL NOTES FOR ADDITIONAL INFORMATION ON WEEP HOLES, STEP REQUIREMENTS, "H" (LIN. FT. FOR MANHOLES) DIMENSIONS, ETC.
2. ALL BASE UNITS ARE TO BE IN ACCORDANCE WITH THE REQUIREMENTS OF AASHTO M199.
3. CONCRETE SHALL BE 4000 PSI.
4. WHERE OPENINGS ARE REQUIRED FOR PIPE, THEY SHALL BE FORMED, DRILLED, OR NEATLY CUT AS APPROVED BY THE ENGINEER. THE CONTRACTOR SHALL FURNISH THE FABRICATOR WITH THE ANGLES BETWEEN CENTER LINES, THE INVERT ELEVATIONS, AND THE SIZE OF ALL PIPES TO ENTER THE MANHOLE. HOLES ARE TO BE A MINIMUM OF 4" TO A MAXIMUM OF 8" LARGER THAN THE OUTSIDE DIAMETER OF THE PROPOSED PIPE.
5. DIMENSIONS SHOWN ARE MINIMUM. ACTUAL DIMENSIONS MAY VARY WITH MANUFACTURER.
6. "D" IS NOMINAL DIAMETER.
7. IN THE EVENT THE INVERT OF THE OUTFALL PIPE IS HIGHER THAN THE BOTTOM OF THE STRUCTURE, THE INVERT OF THE STRUCTURE SHALL BE SHAPED WITH CEMENT MORTAR TO PREVENT STANDING OR PONDING OF WATER IN THE STRUCTURE.
8. TONGUE AND GROOVE JOINT ARE TO BE OF FABRICATOR'S DESIGN MEETING VDOT APPROVAL. JOINTS ARE TO BE SEALED WITH MORTAR, O-RING GASKETS, OR BUTYL RUBBER.

DIMENSIONS

D	X MINIMUM	Y MINIMUM	SUGGESTED MAX. PIPE SIZE	ABSOLUTE MAXIMUM ☆
* 36"	4"	6"	18"	21"
48"	5"	6"	24"	27"
60"	5"	8"	36"	42"
72"	6"	8"	48"	54"
84"	7"	8"	60"	66"
96"	8"	8"	66"	72"

* DEPTH "H" OF 36" DIAMETER BASE UNIT RESTRICTED TO 4'-0" MAXIMUM.

☆ ONE THROUGH PIPE ONLY. (ONE PIPE ENTERING AND ONE PIPE EXITING STRUCTURE)

STANDARD PRECAST BASE UNITS

VIRGINIA DEPARTMENT OF TRANSPORTATION

SPECIFICATION
REFERENCE

105
302