

DIMENSIONS		
PIPE SIZE	H	S
12"	1'-7"	1'-7 3/4"
15"	1'-11"	1'-11 3/4"
18"	2'-2"	2'-2 3/4"
21" OR 24"	2'-8"	2'-8 3/4"

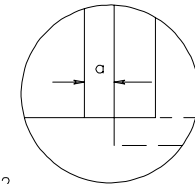
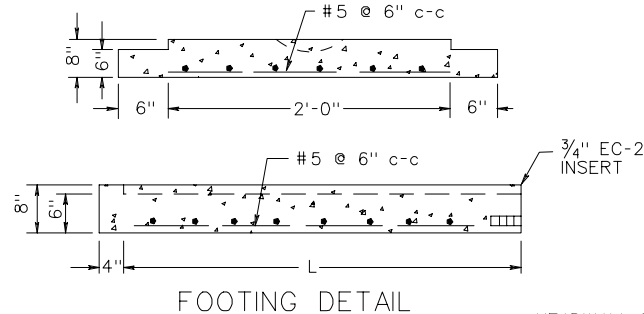
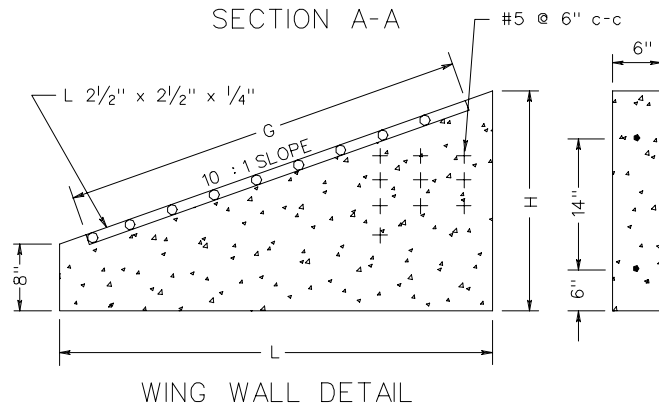
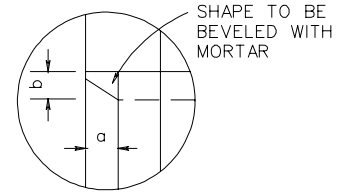
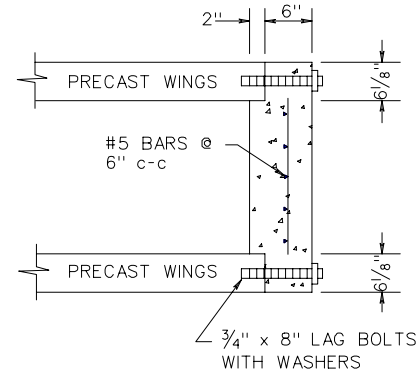
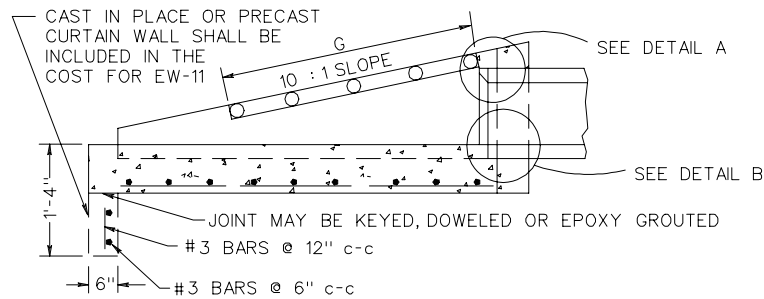

DIMENSIONS					
PIPE SIZE	L	H	G	a	b
12"	11'-0"	1'-9"	10'-7 1/2"	0'-1 1/4"	0'-1"
15"	14'-4"	2'-1"	14'-0"	0'-1 3/4"	0'-1 1/4"
18"	16'-10"	2'-4"	16'-6"	0'-2"	0'-1 1/2"
21" OR 24"	21'-10"	2'-10"	21'-6 1/2"	0'-2 1/2"	0'-2"

CONCRETE TO BE 4000 PSI MINIMUM COMPRESSIVE STRENGTH. IF PIPE IS TO BE SKEWED, THE OPENING WILL BE ADJUSTED TO ACCOMMODATE. REINFORCING STEEL IN ACCORDANCE WITH ASTM A615 (REINFORCING BARS).

PIPE. DIMENSIONS SHOWN ARE MINIMUM. ACTUAL DIMENSIONS MAY VARY WITH MANUFACTURER. BOTTOM OF STRUCTURE TO BE ON THE SAME GRADE AS DRAINAGE DITCH.

FOR DETAILS OF GRATE AND NUMBER OF GRATES REQUIRED SEE EW-11A.

3/8" CHAMFER MAY BE PROVIDED ON ALL EDGES AT MANUFACTURER'S OPTION.

HEADWALL TO BE BEVELED IN ALL AREAS EXCEPT WHERE A CONFLICT WITH INVERT OR WINGWALLS OCCUR.

BEVEL EDGE IS REQUIRED ON THE HEADWALL AT THE INLET END OF THE CULVERT (WHERE THE FLOW ENTERS THE CULVERT).

HEADWALL AT THE OUTLET END OF THE CULVERT MAY BE EITHER SQUARE EDGE OR BEVEL EDGE.

PIPE OPENINGS IN PRECAST DRAINAGE UNITS SHALL NOT EXCEED 4 INCHES AT ANY GIVEN POINT BETWEEN THE PIPE AND THE PRECAST UNIT.

SPECIFICATION REFERENCE

105  
233  
302

## PRECAST PIPE ENDWALL WITH LOAD - CARRYING GRATE FOR 12"-24" PIPES

VIRGINIA DEPARTMENT OF TRANSPORTATION