

FRONT ELEVATION

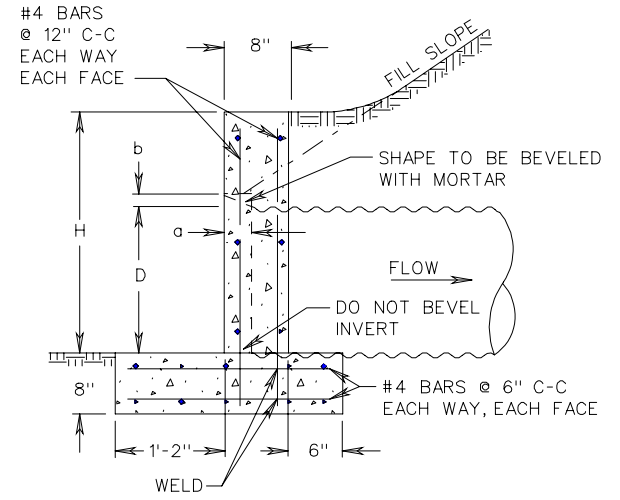

SECTION A-A

NOTES:

1. CONCRETE TO BE 4000 PSI MINIMUM COMPRESSIVE STRENGTH.
2. IF PIPE IS TO BE SKEWED THE OPENING WILL BE ADJUSTED TO ACCOMMODATE.
3. REINFORCING STEEL IN ACCORDANCE WITH ASTM A-615 (REINFORCING BARS).
4. PIPE ARCH OPENINGS IN PRECAST DRAINAGE UNITS SHALL NOT EXCEED 4 INCHES AT ANY GIVEN POINT BETWEEN THE PIPE AND THE PRECAST UNIT.
5. DIMENSIONS SHOWN ARE MINIMUM. ACTUAL MEASUREMENTS MAY VARY WITH MANUFACTURER'S TOLERANCE.
6. IN NO CASE SHALL TOP OF ENDWALL PROJECT ABOVE FILL SLOPE, OR SHOULDER.
7. HEADWALL TO BE BEVELED IN ALL AREAS EXCEPT WHERE A CONFLICT WITH INVERT OR WINGWALL OCCUR.
8. BEVEL EDGE IS REQUIRED ON THE HEADWALL AT THE INLET END OF THE CULVERT HEADWALL AT OUTLET END MAY BE EITHER SQUARE EDGE OR BEVELED.
9. 3/4" CHAMFER MAY BE PROVIDED ON ALL EDGES AT MANUFACTURER'S OPTION.

PRECAST ENDWALL DIMENSIONS

S	D	M	G	L	H	a	b
17"	13"	2'-6"	2'-2"	6'-10"	2'-3"	0'-2"	0'-1 1/4"
21"	15"	2'-10"	2'-7"	8'-0"	2'-5"	0'-2 1/2"	0'-1 1/2"
24"	18"	3'-1"	3'-1"	9'-3"	2'-8"	0'-3"	0'-2"
28"	20"	3'-5"	3'-6"	10'-5"	2'-10"	0'-3"	0'-2"
35"	24"	4'-0"	4'-3"	12'-6"	3'-2"	0'-4"	0'-2 1/2"
* 40"	31"	4'-10"	5'-2"	15'-2"	3'-7"	0'-4 1/2"	0'-3"
* 46"	36"	5'-7"	6'-0"	17'-7"	3'-11"	0'-5 1/2"	0'-3 1/2"
* 53"	41"	6'-6"	6'-11"	20'-4"	4'-4"	0'-6"	0'-4"
57"	38"						

* DIMENSIONS FOR 3" X 1" AND 5" X 1" CORRUGATION

SPECIFICATION REFERENCE
105
302

PRECAST ENDWALLS FOR MULTIPLE PIPE ARCHES
13"-38" RISE