

FRONT ELEVATION

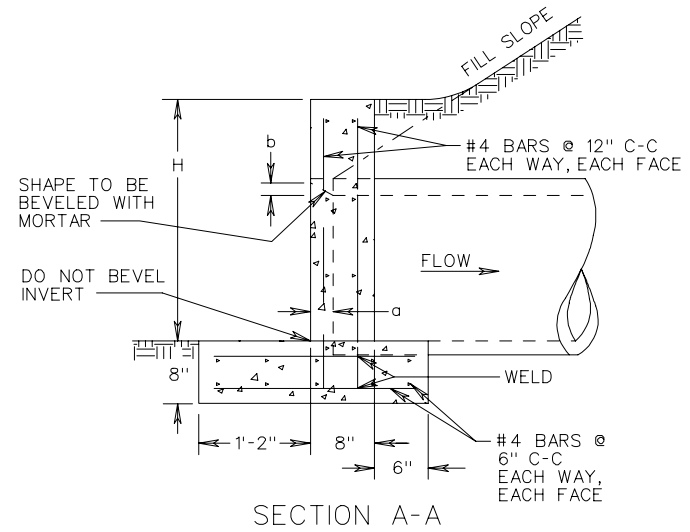

SECTION A-A

NOTES:

1. CONCRETE TO BE 4000 PSI MINIMUM COMPRESSIVE STRENGTH.
2. IF PIPE IS TO BE SKEWED THE OPENING WILL BE ADJUSTED TO ACCOMMODATE ANGLES UP TO 15°.
3. REINFORCING STEEL IN ACCORDANCE WITH ASTM A-615 (REINFORCING BARS).
4. PIPE OPENINGS IN PRECAST DRAINAGE UNITS SHALL NOT EXCEED 4 INCHES AT ANY GIVEN POINT BETWEEN THE PIPE AND THE PRECAST UNIT.
5. DIMENSIONS SHOWN ARE MINIMUM. ACTUAL MEASUREMENTS MAY VARY WITH MANUFACTURER'S TOLERANCE.
6. IN NO CASE SHALL TOP OF ENDWALL PROJECT ABOVE FILL SLOPE, DITCH SLOPE, OR SHOULDER.
7. HEADWALL TO BE BEVELED IN ALL AREAS EXCEPT WHERE A CONFLICT WITH INVERT OR WINGWALL OCCUR.
8. BEVEL EDGE IS REQUIRED ON THE HEADWALL AT THE INLET END OF THE CULVERT (WHERE THE FLOW ENTERS THE CULVERT). HEADWALL AT OUTLET END MAY BE EITHER SQUARE EDGE OR BEVELED.
9. 3/4" CHAMFER MAY BE PROVIDED ON ALL EDGES AT MANUFACTURER'S OPTION.

FOR CIRCULAR CONCRETE OR CORRUGATED METAL PIPE
FOR MULTIPLE PIPE ENDWALL

D	H	L	S	G	a	b
12"	2'-0"	5'-10"	2'-0"	1'-11"	0'-1 1/4"	0'-1"
15"	2'-3"	7'-3"	2'-3"	2'-6"	0'-1 3/4"	0'-1 1/4"
18"	2'-6"	8'-8"	2'-8"	3'-0"	0'-2"	0'-1 1/2"
21" OR 24"	3'-2"	11'-6"	3'-6"	4'-0"	0'-2 1/2"	0'-2"
27" OR 30"	3'-10"	14'-4"	4'-4"	5'-0"	0'-3 1/4"	0'-2 1/2"
33" OR 36"	4'-4"	17'-2"	5'-2"	6'-0"	0'-3 3/4"	0'-3"

PRECAST ENDWALL FOR MULTIPLE PIPE CULVERTS
12"-36" PIPE CULVERTS

VIRGINIA DEPARTMENT OF TRANSPORTATION

SPECIFICATION REFERENCE

105
302