

TYPE "A"
(SCREW TYPE)

TYPE "A"

EXTENSION RANGE - C	DIM. A	DIM. B	DIM. D
18"-24"	10.5"	14.5"	6.5"
24"-29"	15"	24"	6.5"
36"-48"	15"	36"	8.5"
36"-60"	26"	36"	8.5"

LONGER BOXES ARE MADE BY ADDING EXTENSIONS.

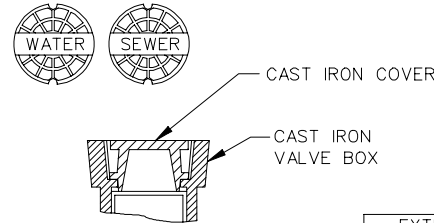

TYPE "B"

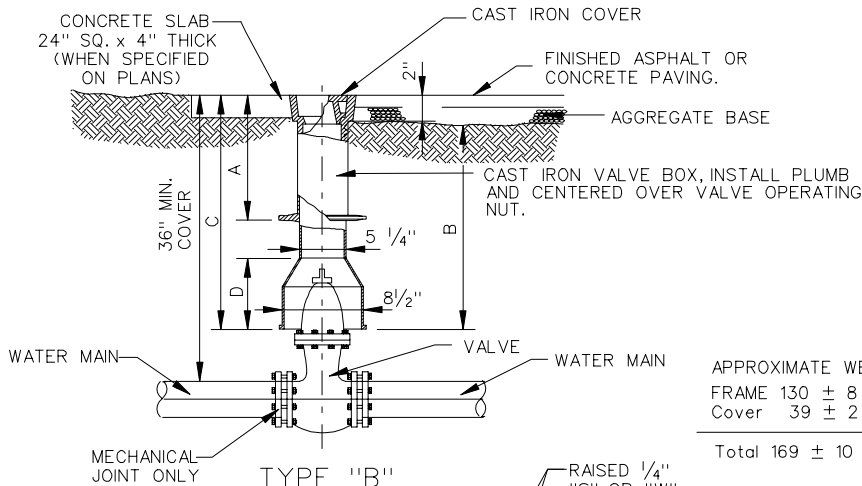

TYPE "B"
(SLIP TYPE)

EXTENSION RANGE - C	DIM. A	DIM. B	DIM. D
18"-24"	10.5"	15"	6.5"
23"-29"	15.5"	15"	6.5"
24"-36"	15.5"	24.5"	6.5"
36"-48"	15.5"	26"	8.5"
38"-48"	26.5"	24.5"	6.5"
36"-60"	26.5"	36"	8.5"

LONGER BOXES ARE MADE BY ADDING EXTENSIONS.

APPROXIMATE WEIGHTS
 FRAME 130 ± 8 LBS.
 Cover 39 ± 2 LBS.
 Total 169 ± 10 LBS.

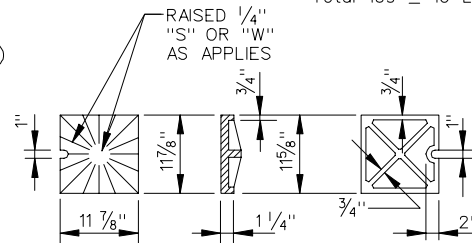

TYPE "C"

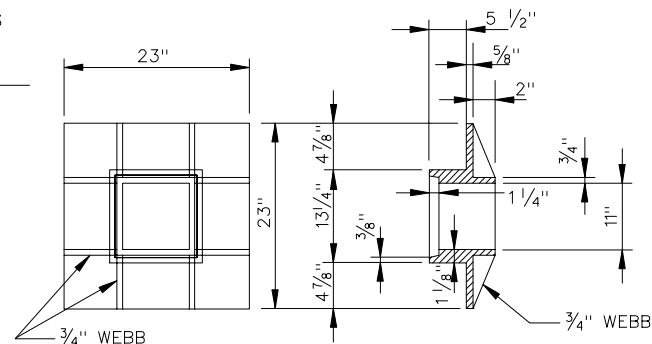

NOTE:

1. CAST IRON SHALL CONFORM TO ASTM A-48M CLASS 30S.

VALVE BOX AND VALVE MANHOLE
 WATER AND SANITARY SEWER FACILITIES