

Signs having a height greater than 10' may have one horizontal joint. Horizontal joint shall be between lines of message.

SECTION A-A

SECTION B-B

ALL INSTALLATIONS EXCEPT TOP AND BOTTOM ZEE BARS ON OVERHEAD SIGNS

TOP AND BOTTOM ZEE BAR INSTALLATION ON OVERHEAD SIGNS

3/8" diameter rivet - Rivets shall be dome head, break mandrel, blind rivets conforming to Industrial Fasteners Institute Standard IFI-114, Style 1, Grades 10 or 11 except that the minimum ultimate tensile strength shall be 360 pounds. Rivets shall have a grip range accommodating the combined thickness of the sign panel and zee bar and shall be installed in accordance with the manufacturer's recommendations.

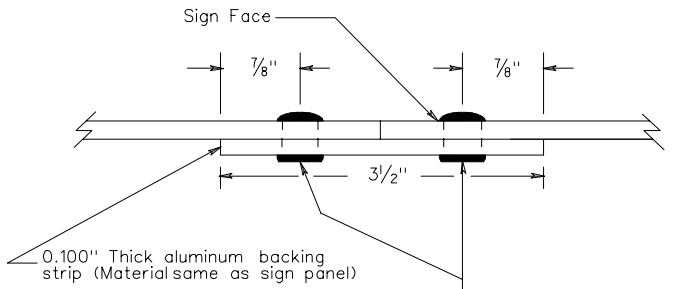
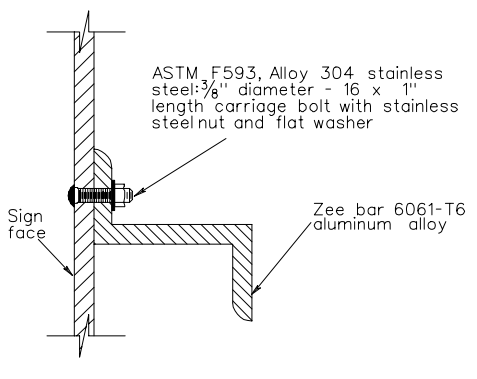
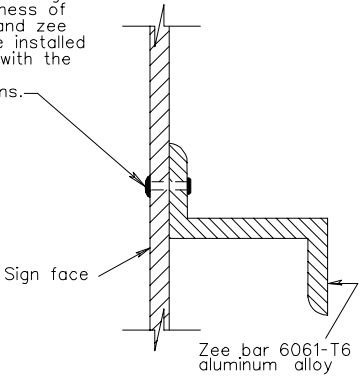

Rivet (Same as used for connecting sign to zee bar). In lieu of using rivets, tape equal to 3M's VHB Double Coated Acrylic Foam Tape may be used except on horizontal backing strip. Tape shall be installed in accordance with the manufacturer's recommendations.

SIGN PANEL DESIGN