

TYPICAL FOR PRESTRESSED CONCRETE BEAM

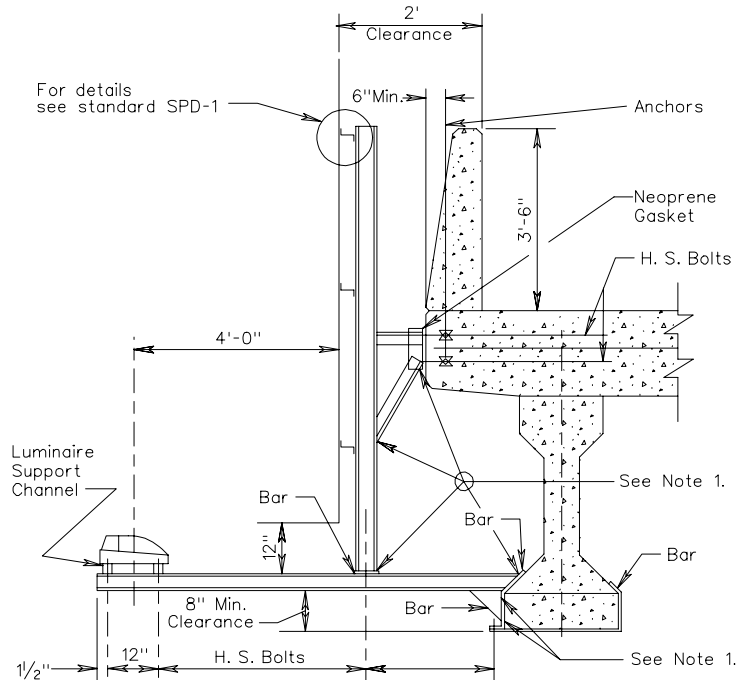

This parapet is not typical for bridges with a sidewalk.
Bridge plans shall be reviewed for project specific parapet/rail.

TYPICAL FOR STEEL BEAM/GIRDER

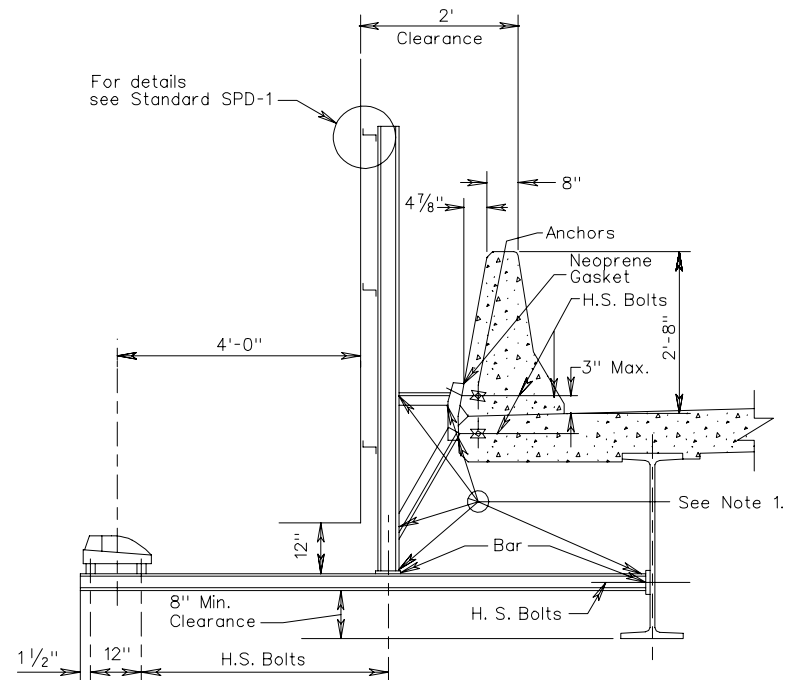

Bridge plans shall be reviewed for project specific parapet/rail.

NOTES:

1. The size of members and weld size(s) shall be designed by the contractor for the sign to be supported. Minimum size fillet weld shall be $\frac{1}{4}$ ".
2. Minimum clearances are as specified by AASHTO or approved by the Virginia Department of Transportation.
3. For attachment to concrete superstructures or to painted or galvanized steel superstructures, supporting frame may be either aluminum or galvanized steel. For attachment to unpainted weathering steel superstructures, the supporting frames shall be with weathering steel.
4. The spacing of zees and supports shall be as shown on the plans.
5. Sign supports shall be braced for lateral forces.
6. Bolts shall be High-Strength ASTM A325, galvanized except when attachment is made to unpainted weathering steel in which case bolts shall be ASTM A325 Type 3.

Anchors shall be cast-in-place. Thru-bolting may also be used for attachments to parapets. When cast-in-place anchors are used, they shall develop the strength of the bolts. When thru-bolting is used, anchorage on the traffic side of the parapet shall be flush with the parapet face.

Anchors shall be placed no higher than 3" above top of deck slab. Adhesive anchors (with epoxy or non-shrink grout) shall not be allowed.

7. When required by the plans bridge mounted sign structure luminaires shall be installed on a luminaire retrieval system with supports and electrical system designed for track mounted luminaires. Retrieval system including the electrical system shall be equal to "LUMI-TRAK" and designed for the number of luminaires as indicated on the plans. Spacing of hangers used to support the retrieval system shall be increased to a maximum 7-foot distance only where hangers do not support sign panels. Turntable end of retrieval system shall be of sufficient length to align with the vertical edge of the outside paved shoulder (± 6 ") or shall extend five feet beyond the vertical edge (± 6 ") of outermost sign luminaire whichever is greater. The opposite end of retrieval system shall extend a minimum of 6 inches past the outermost vertical edge of the sign hanger arm. Luminaire support channels and associated equipment will not be required with the luminaire retrieval system.

TYPICAL BRIDGE PARAPET SIGN MOUNTING DETAILS

VIRGINIA DEPARTMENT OF TRANSPORTATION