

SIGN POST AND FOUNDATION STUB POST ELEVATION

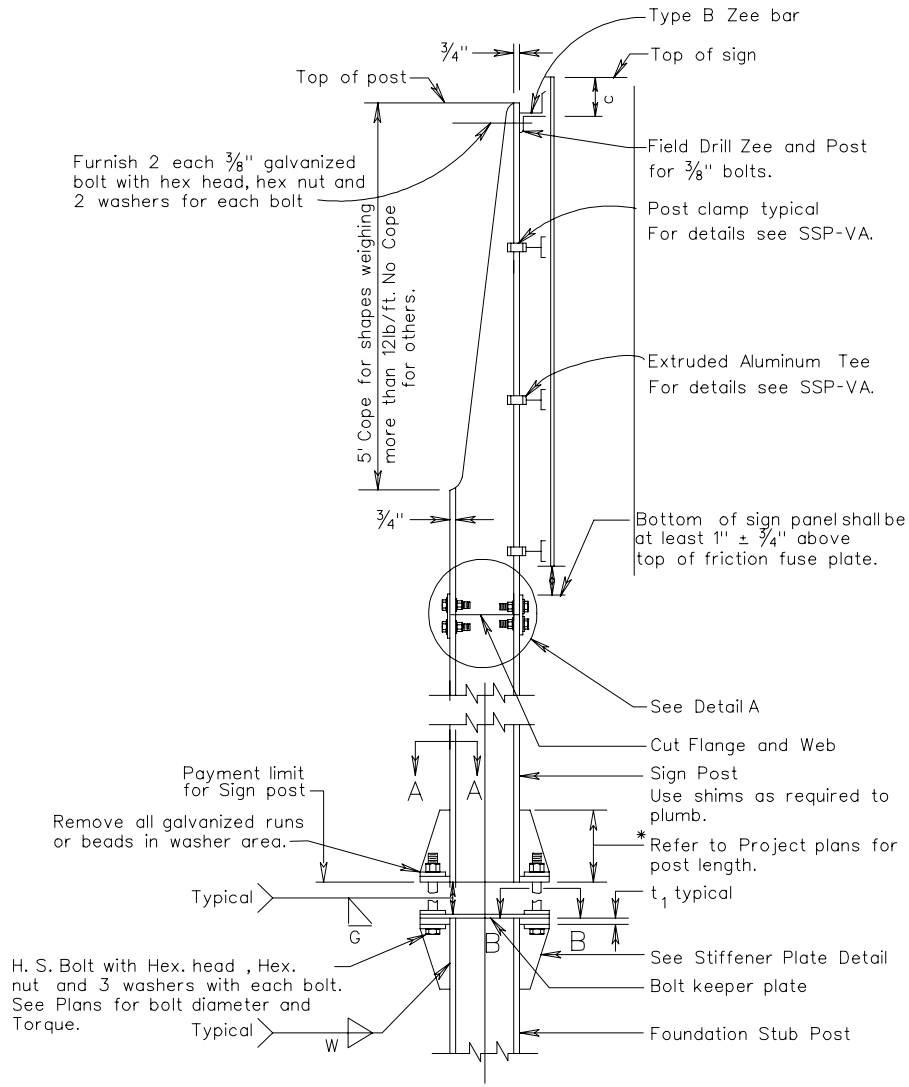

SECTION A-A

SECTION B-B

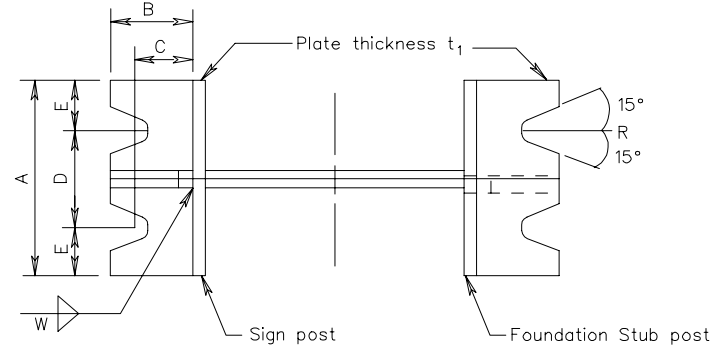

DETAIL A

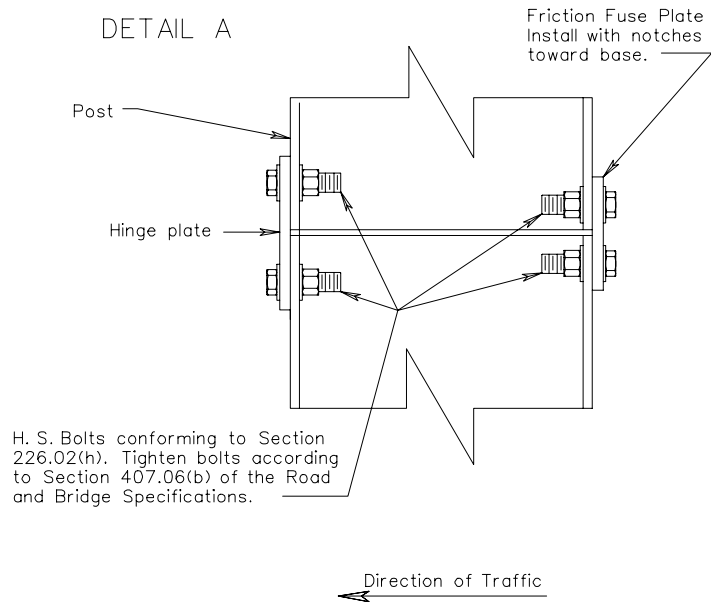

TYPICAL DETAILS FOR TYPE VIA
INTERSTATE SIGN STRUCTURES