

METHOD OF POST DRILLING

SIDE VIEW

Bore holes shall be thoroughly saturated with a water-borne preservative conforming to Section 236 of the Road and Bridge Specifications

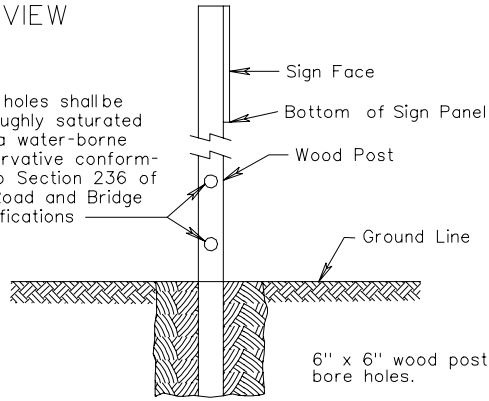

6" x 6" wood post requires two 2" bore holes.

6" x 8" wood post requires two 3" bore holes. Posts less than 6" x 6" do not require bore holes.

FRONT VIEW

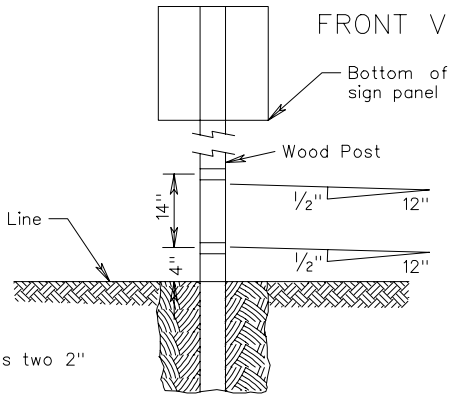

FLAT CUT



SHED CUT

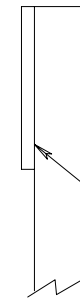
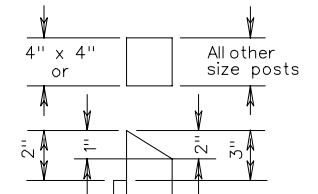

Sign Face

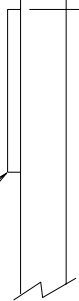

PYRAMIDAL CUT

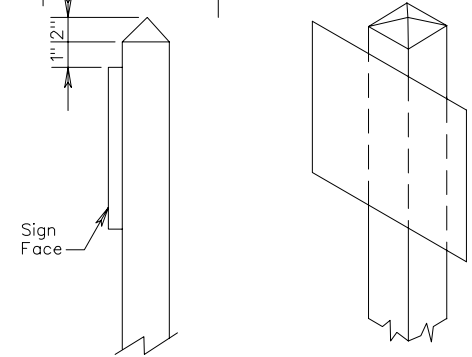
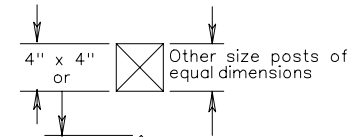

Note:

Flat cut wood post is shown on Types A through X as typical. Shed cut and pyramidal cut wood post designs may be used; however, the style of wood post shall be uniform throughout a project.

SIGN PANEL ATTACHMENT DETAILS

WOOD POSTS

(For Sign Panel Attachment To Z Bars, See Standard SPD-1)

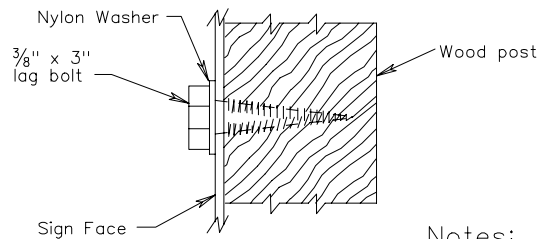

ALUMINUM FRAMING

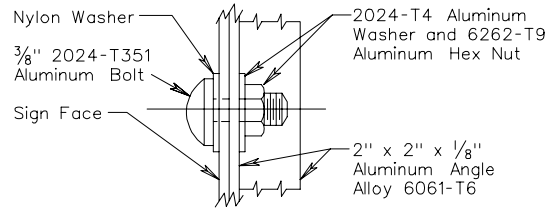

Notes:

Nylon washer shall be 1/8 inch thick minimum with an outside diameter of 1 inch and an inside diameter of 7/16 inch

To obtain a flush mounting surface for signs, all wood shall be mortised where necessary, to receive flange of aluminum angle.

TYPICAL DETAILS FOR STANDARD WOOD POST STRUCTURE TYPES

VIRGINIA DEPARTMENT OF TRANSPORTATION