

To service entrance safety switch

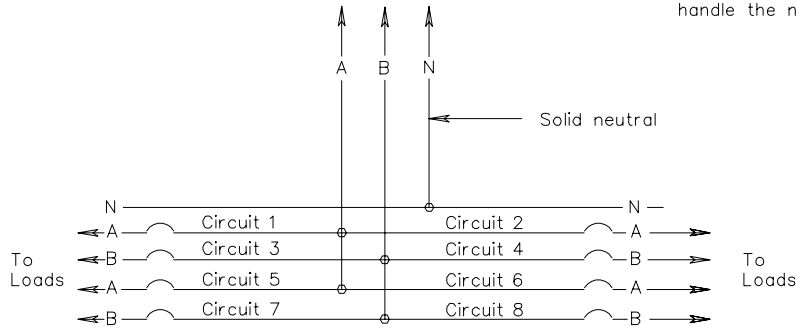

TYPE A

To service entrance safety switch

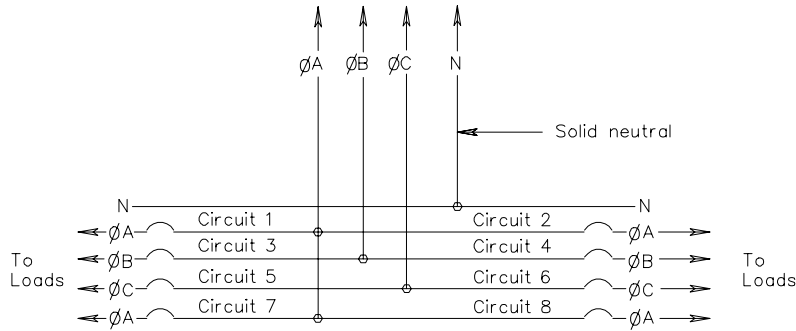

TYPE B

\* Contactors shall be 2 poles for single phase and 3 poles for three phase services. Number of contactors shall be as required to handle the number of circuits actually being utilized.

To service entrance safety switch

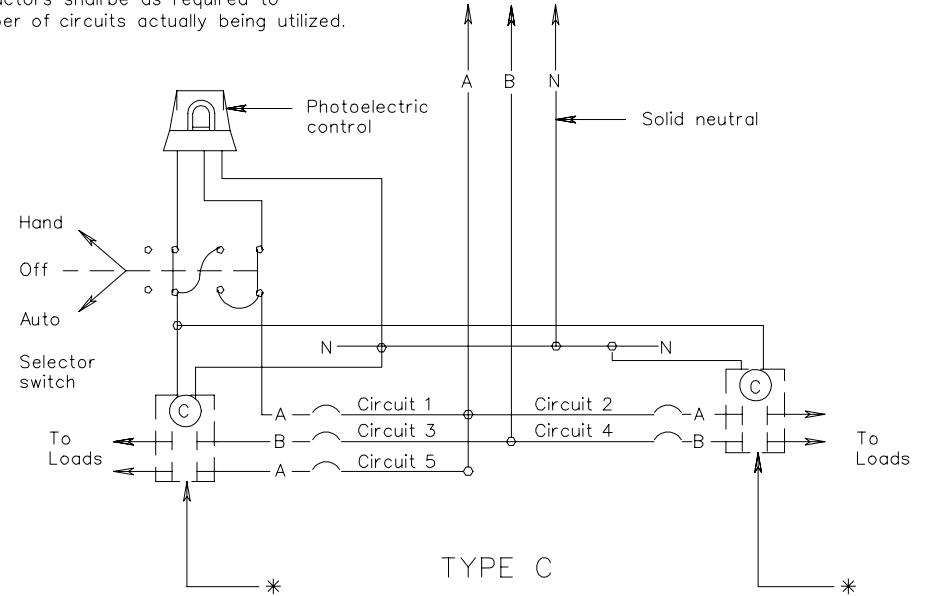

TYPE C

To service entrance safety switch

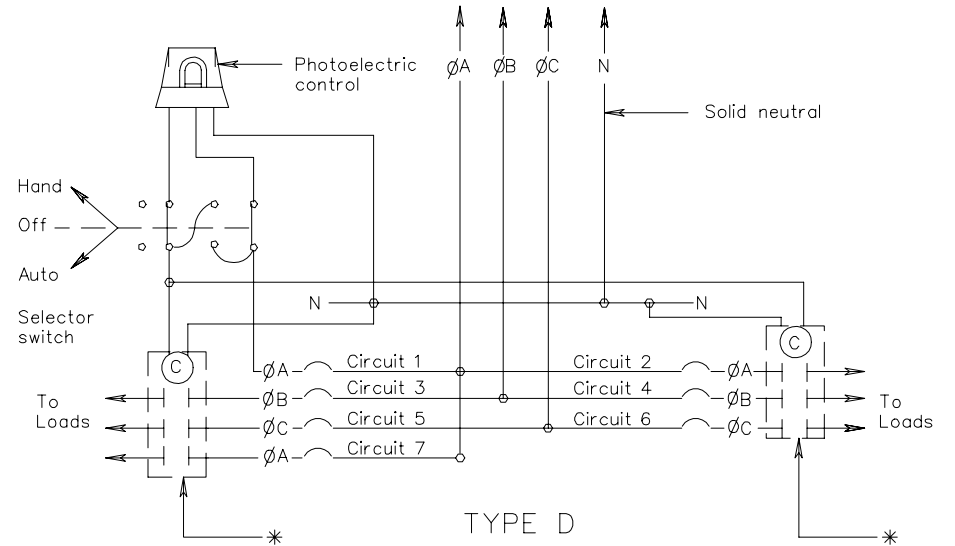

TYPE D

Notes:

All circuit breakers shall be single pole.

Voltage and amperage ratings of contactors and breakers shall be as indicated on the plans.

Number of circuits shown are typical. Exact number required shall be as indicated on the plans.

CONTROL CENTER WIRING  
DETAILS