

POLE TOP MOUNTING CAST ALUMINUM SIGNAL HEADS ONLY POLE TOP MOUNTING CAST ALUMINUM OR POLYCARBONATE SIGNAL HEADS POLE BRACKET MOUNTING CAST ALUMINUM OR POLYCARBONATE SIGNAL HEADS

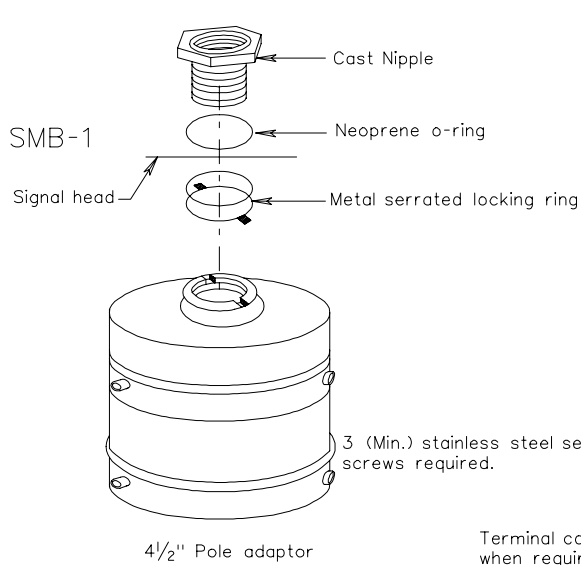

POLE AND HANGAR ASSEMBLY HARDWARE REQUIREMENTS

IF POLE IS	HARDWARE SHALL BE
Galvanized steel	Aluminum or galvanized iron
Steelpainted alum.	Aluminum galvanized iron or iron painted aluminum
Steelpainted other than aluminum; Fiberglass tone other than gray	Aluminum or iron painted to match pipe
Wood or fiberglass with gray tone	Aluminum or galvanized iron

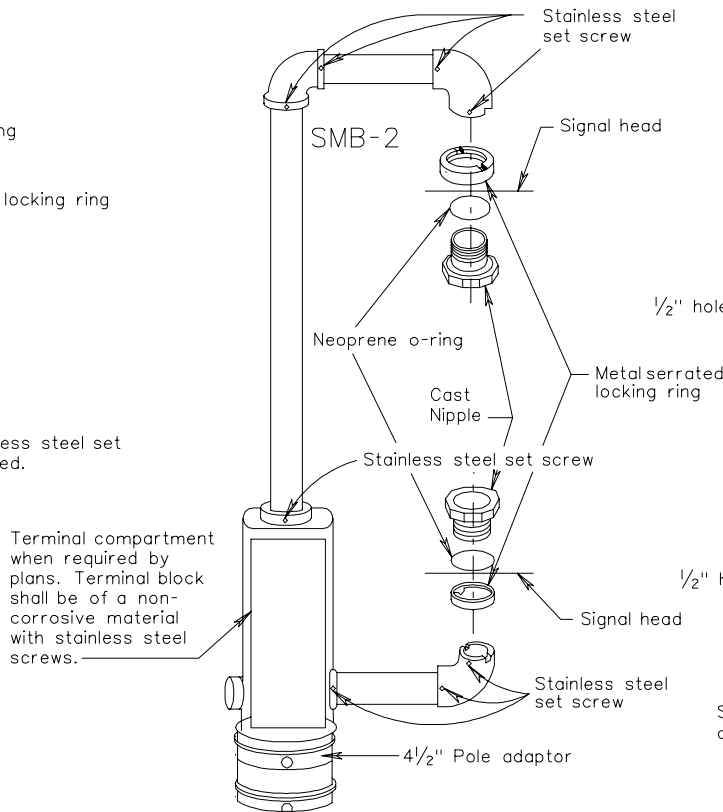

SMB-3

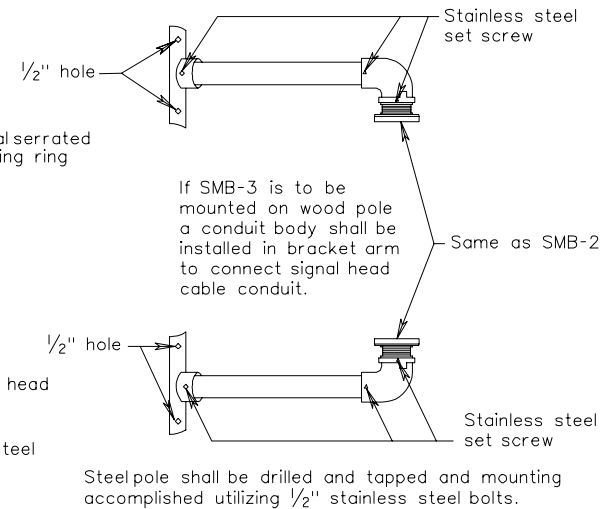

Notes:

If pedestrian signals are being installed, the mounting attachments (SMB-1,2,3) shall be a type specifically manufactured for that purpose.

SMB-1, 2 and 3 shown are typical and for one way signal display. Other designs may be submitted for approval by the Engineer. Multi-way assemblies, when required, shall be of similar appropriate design.

SIGNAL HEAD MOUNTING DETAILS
POLE TOP AND BRACKET