

SPAN WIRE INSTALLATION

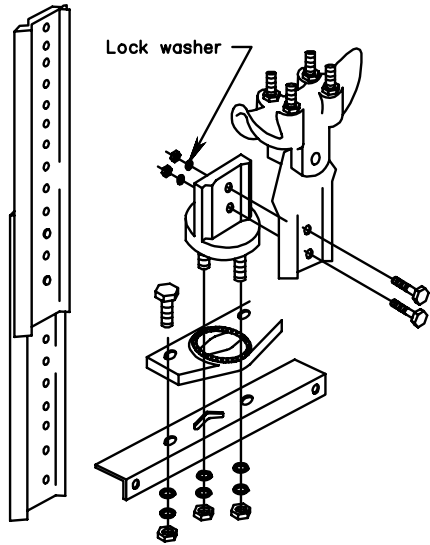

Spacers shall be installed between the eyelet of the sign hanger and the span wire clamp to eliminate any gap.

Note:

All nuts, bolts and washers shall be stainless steel or galvanized steel unless otherwise indicated.

Extension shall be used with the hanger and tether assembly to center the sign with the signal heads.

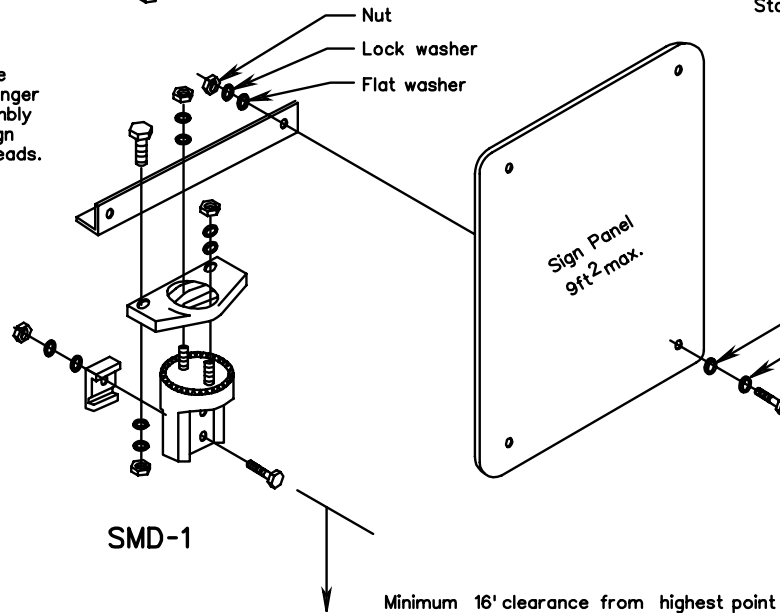

MAST ARM INSTALLATION

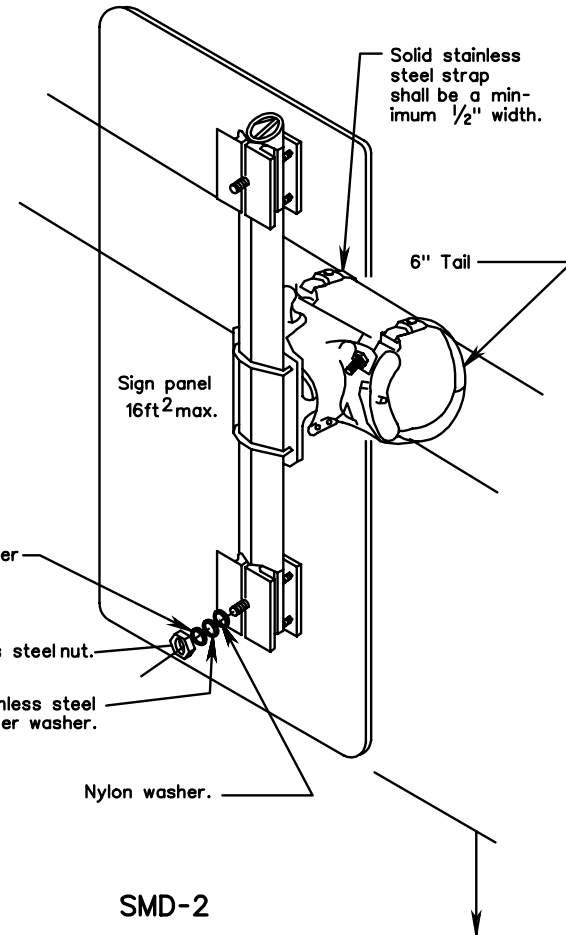

NOTES

Nuts and bolts used for attachment of sign panel shall be stainless steel and 3/4" in diameter.

A 1/4" nylon and stainless steel fender washer shall be used on the front of sign panel where bolt passes through sign panel.

SIGN MOUNTING DETAILS

VIRGINIA DEPARTMENT OF TRANSPORTATION