

NOTE:

GRATE AND COLLAR ARE TO BE GALVANIZED AFTER FABRICATION. COST OF THIS GRATE AND COLLAR ARE TO BE INCLUDED IN THE PRICE BID FOR STORMWATER MANAGEMENT DRAINAGE STRUCTURE.

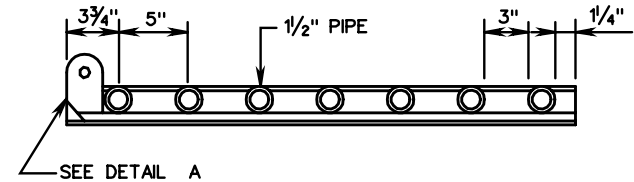

SECTION A-A

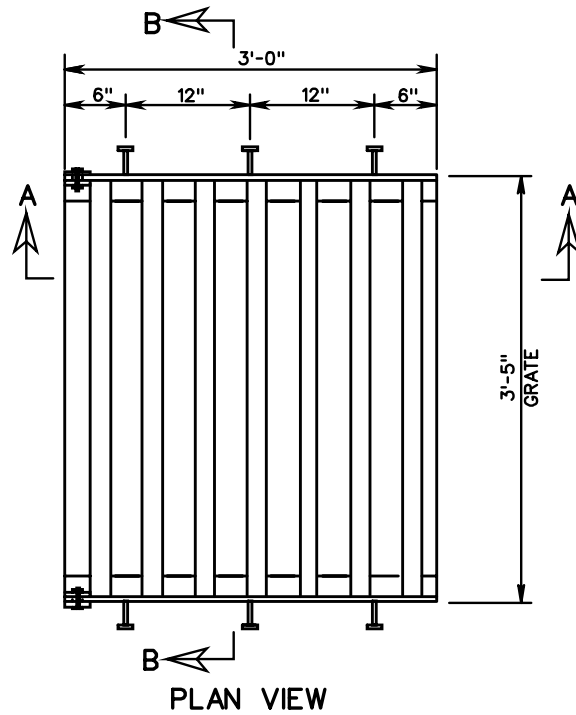
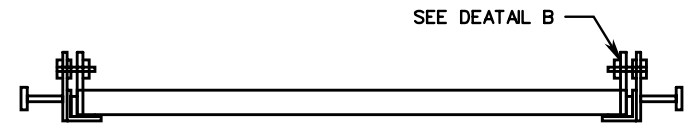

SECTION B-B

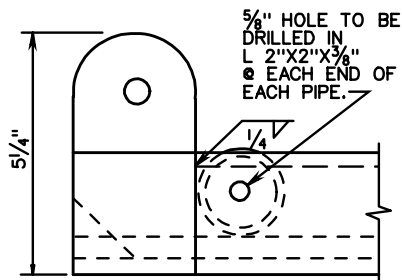

DETAIL A INSIDE

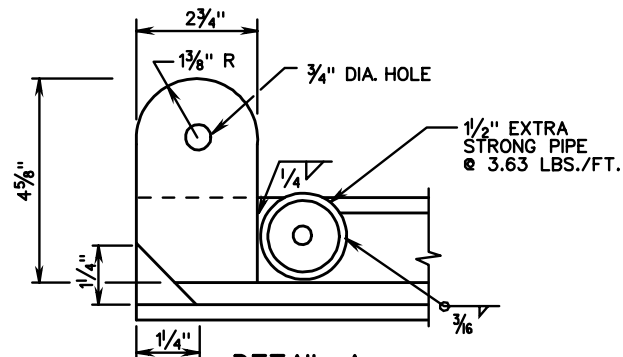

DETAIL A OUTSIDE

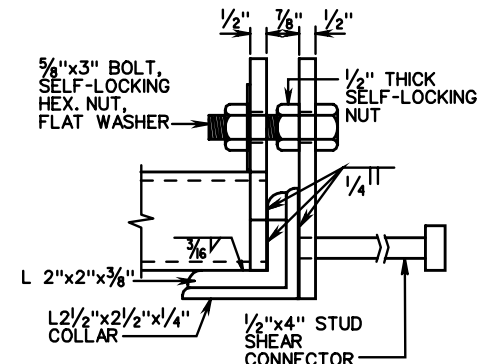

DETAIL B

SPECIFICATION REFERENCE

302

STORMWATER MANAGEMENT DRAINAGE STRUCTURE GRATE DETAILS

VIRGINIA DEPARTMENT OF TRANSPORTATION

VDOT

ROAD AND BRIDGE STANDARDS

REVISION DATE

SHEET 3 OF 3

114.03