

TYPICAL DEWATERING BASIN

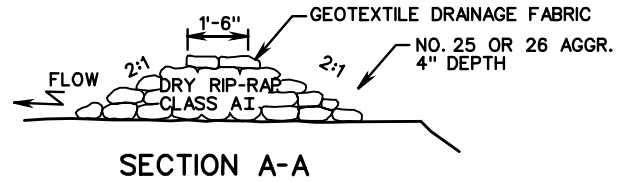

* GEOTEXTILE DRAINAGE FABRIC TO COVER INSIDE FACE OF BALED STRAW BERM.

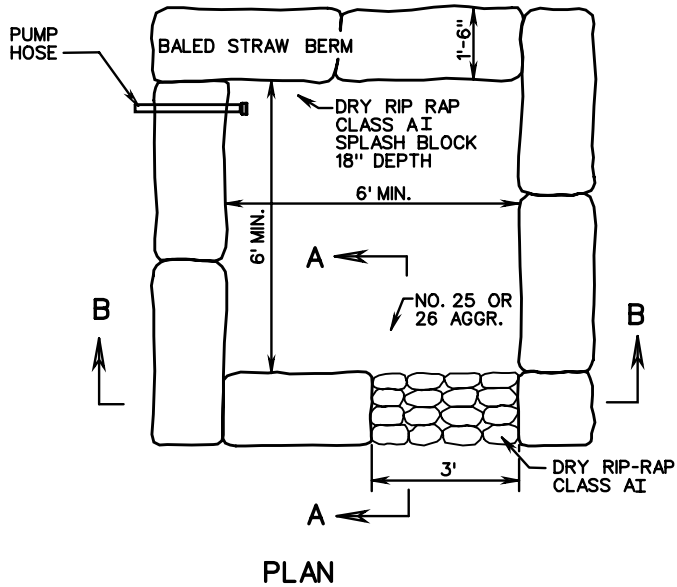
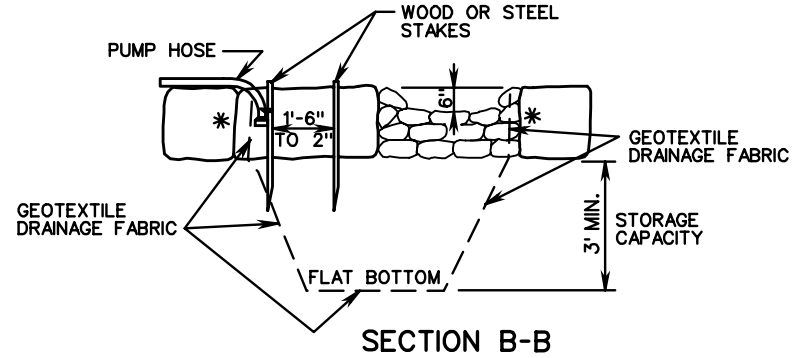

NOTES:

1. DEWATERING BASIN SIZE SHALL BE DETERMINED BY THE FORMULA $16 \times \text{GAL./MIN. OF PUMP} = \text{CU. FT. OF STORAGE CAPACITY}$.
2. THIS WORK SHALL CONSIST OF THE CONSTRUCTION OF A DEWATERING BASIN FOR THE PURPOSE OF RECEIVING SEDIMENT-LADENED WATER PUMPED FROM A CONSTRUCTION SITE TO ALLOW FOR FILTRATION BEFORE IT REENTERS THE WATERWAY. PUMPING INTO THESE BASINS SHALL CEASE WHEN THE FLOW FROM THE BASIN BECOMES SEDIMENT-LADENED.
3. SURFACE WATER FLOW SHALL BE DIVERTED AROUND THIS DEVICE.
4. THE OUTFALL FROM THE BASIN(S) SHALL HAVE A STABILIZED CONVEYANCE TO RECEIVING WATERS.
5. ONCE THE DEWATERING BASIN BECOMES FILLED TO HALF OF THE STORAGE CAPACITY, ACCUMULATED SEDIMENT SHALL BE REMOVED AND DISPOSED OF IN AN APPROVED DISPOSAL AREA OUTSIDE OF THE 100-YEAR FLOODPLAIN UNLESS OTHERWISE APPROVED ON THE PLANS.
6. SEDIMENT CONTROL DEVICES ARE TO REMAIN IN PLACE UNTIL ALL DISTURBED AREAS ARE STABILIZED AND THE ENGINEER APPROVES THEIR REMOVAL. GROUND CONTOURS SHALL BE RETURNED TO THEIR ORIGINAL CONDITION UNLESS SPECIFICALLY APPROVED OTHERWISE BY THE ENGINEER.
7. SYNTHETIC PRODUCTS THAT HAVE BEEN APPROVED FOR USE ON VDOT PROJECTS AND FOUND ON VDOT'S SPEL LIST MAY BE USED IN LIEU OF THIS DESIGN. HOWEVER, VDOT WILL ONLY COMPENSATE THE CONTRACTOR UP TO THE BID PRICE PER EACH AT EACH SITE.

TYPICAL SYNTHETIC PRODUCT

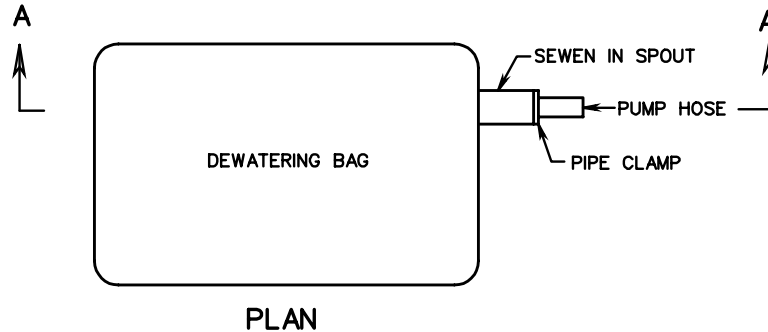
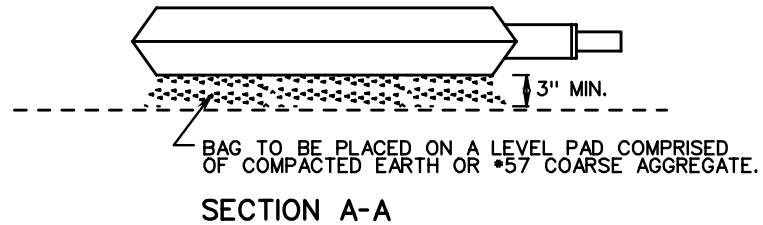

ROAD AND BRIDGE STANDARDS

SHEET 1 OF 1

REVISION DATE

113.12

DEWATERING BASIN

VIRGINIA DEPARTMENT OF TRANSPORTATION

SPECIFICATION REFERENCE

107
303