

**NOTE:**

GRATE AND COLLAR ARE TO BE GALVANIZED AFTER FABRICATION. COST OF THIS GRATE AND COLLAR ARE TO BE INCLUDED IN THE PRICE BID FOR STORMWATER MANAGEMENT DRAINAGE STRUCTURE.

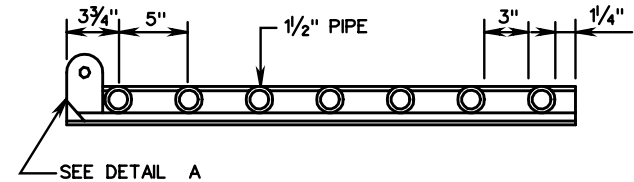

SECTION A-A

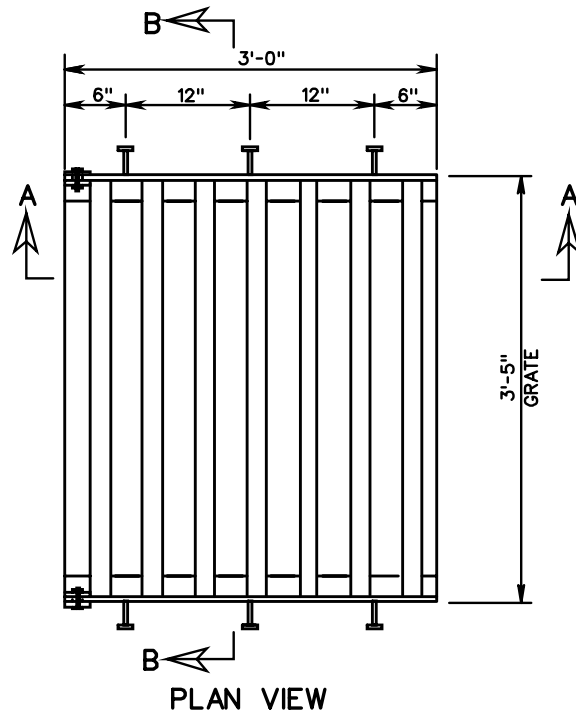
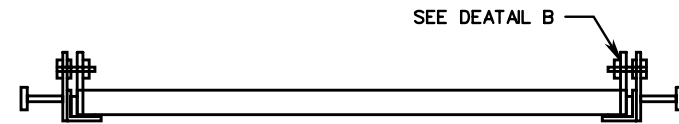

SECTION B-B

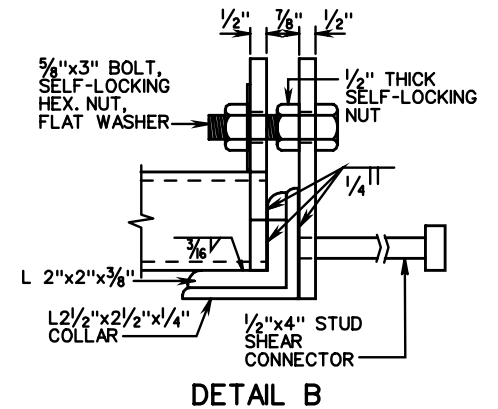
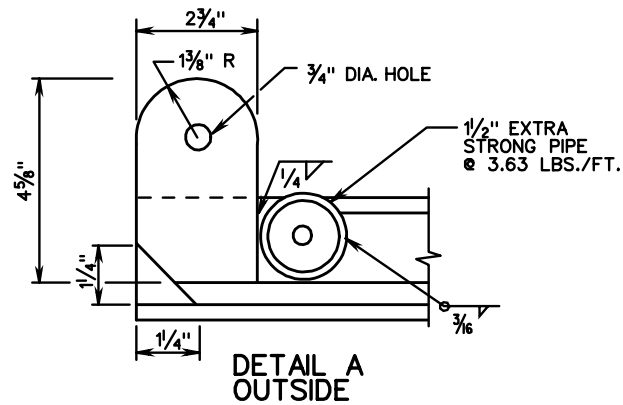
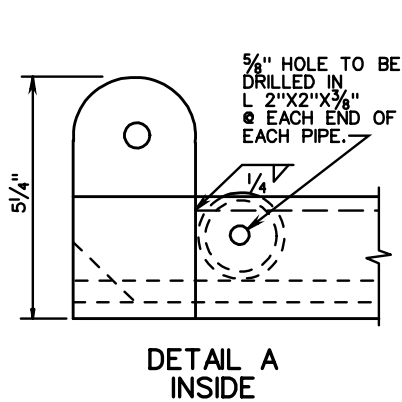

SPECIFICATION REFERENCE

302

**STORMWATER MANAGEMENT DRAINAGE STRUCTURE GRATE DETAILS**

VIRGINIA DEPARTMENT OF TRANSPORTATION

**VDOT**

ROAD AND BRIDGE STANDARDS

REVISION DATE

SHEET 3 OF 3

114.03