

UD-5

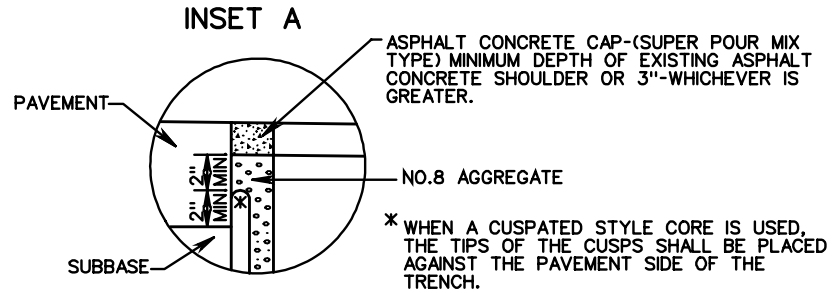

PAVED SHOULDER SECTION

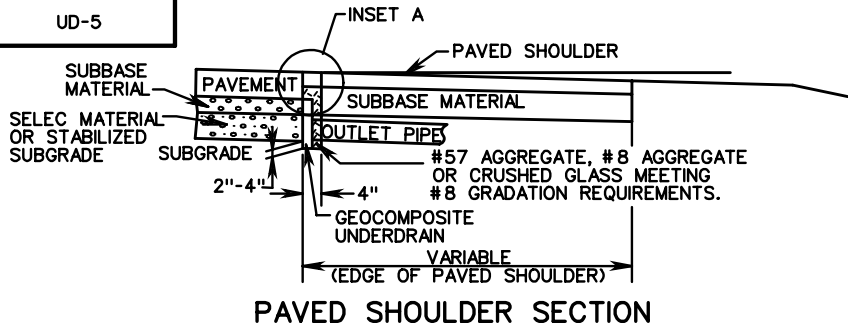
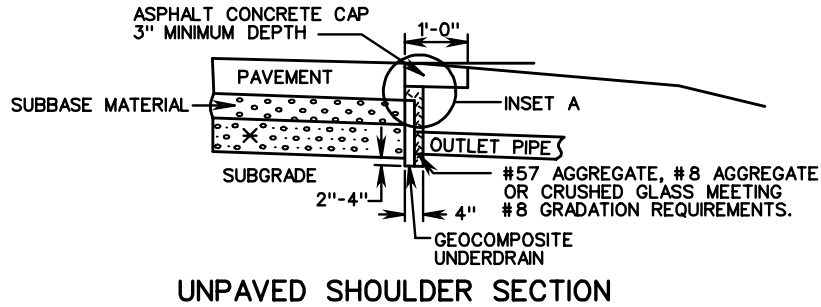

UNPAVED SHOULDER SECTION

\* SELECT MATERIAL OR STABILIZED SUBGRADE MATERIAL

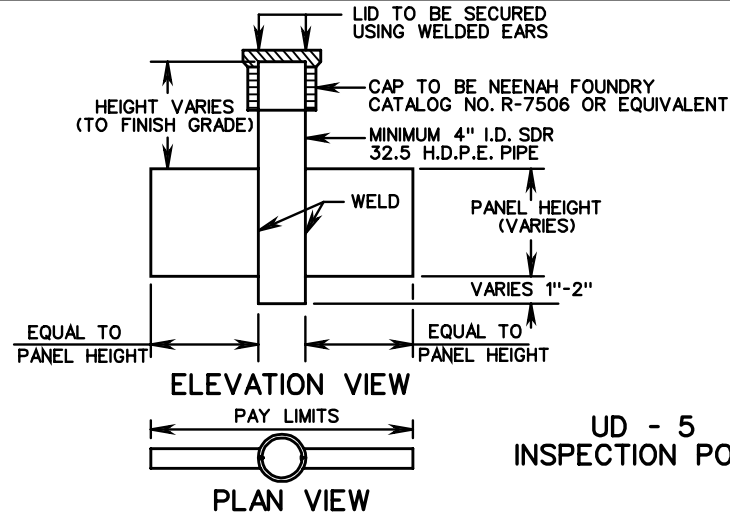

UD - 5 INSPECTION PORT

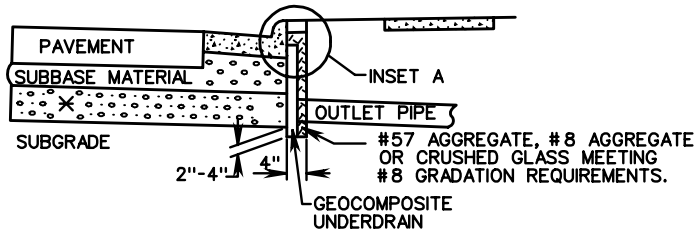

CURB AND GUTTER SECTION

\* SELECT MATERIAL OR STABILIZED SUBGRADE MATERIAL

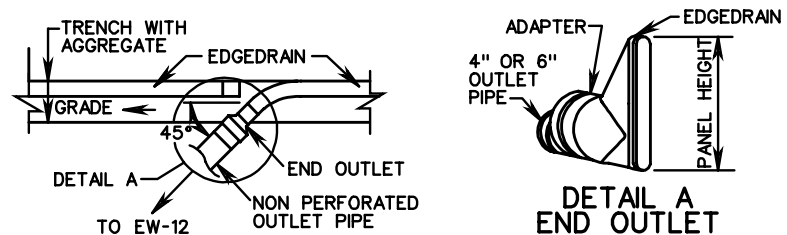

EDGEDRAIN CONNECTION TO OUTLET PIPE

NOTES:

1. INVERT ELEVATION AT OUTLET END OF OUTLET PIPE TO BE A MINIMUM OF 1'-0" ABOVE INVERT ELEVATION OF RECEIVING DRAINAGE DITCH OR STRUCTURE.
2. ALL CONNECTIONS (ELBOWS, WYES, ETC.) WITHIN PAY LIMITS FOR OUTLET PIPE ARE TO BE OF THE SAME CRUSHING STRENGTH AS THE OUTLET PIPE.
3. OUTLET PIPES ARE TO BE INSTALLED ON 2% MIN. (3% DESIRABLE) GRADE AND LOCATED EVERY 350' MAXIMUM OR AS NOTED ON PLANS.
4. OUTLET PIPE TO BE SECURELY CONNECTED TO EW-12 OR OTHER DRAINAGE STRUCTURE.
5. UD-5 INSPECTION PORTS ARE TO BE LOCATED WHERE SPECIFIED ON THE PLANS.

NON-PERFORATED OUTLET PIPE

TYPE OF PIPE	CRUSHING STRENGTH	
	W.T. 4" NOM. DIAMETER	W.T. 6" NOM. DIAMETER
CORRUGATED ALUMINUM		0.048
SMOOTH WALL PVC	.103	0.153
SMOOTH WALL PE	70 PSI ***	70 PSI ***

\* WALL THICKNESS (MIN) - INCHES  
 \*\*\* TESTED ACCORDING TO ASTM D-2412 AT 5% DEFLECTION.



ROAD AND BRIDGE STANDARDS

SHEET 1 OF 1

REVISION DATE

108.08

PREFABRICATED GEOCOMPOSITE RETROFIT PAVEMENT EDGEDRAIN

VIRGINIA DEPARTMENT OF TRANSPORTATION

SPECIFICATION REFERENCE

240  
501  
701