

**CURB DROP INLET THROAT SECTION**

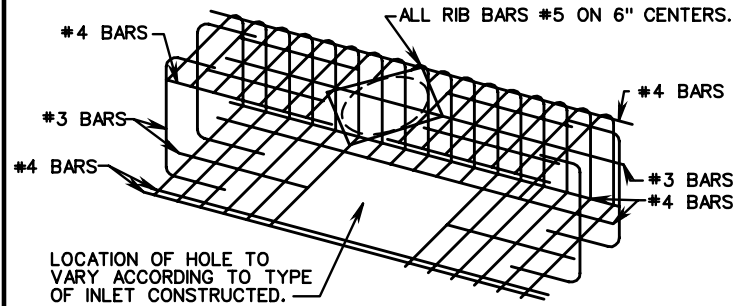

**TYPICAL MINIMUM BAR REINFORCEMENT**

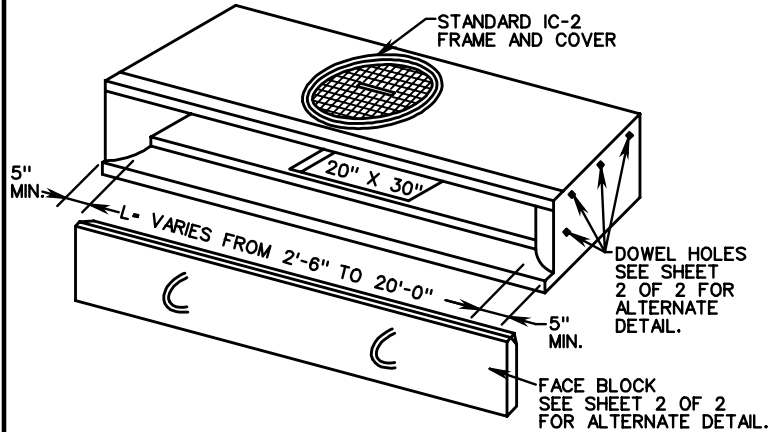
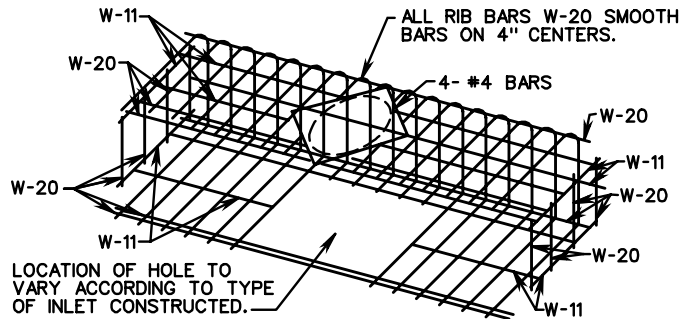

**TYPICAL MINIMUM WELDED WIRE REINFORCEMENT**

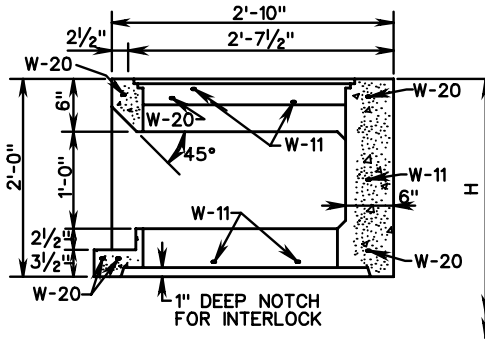
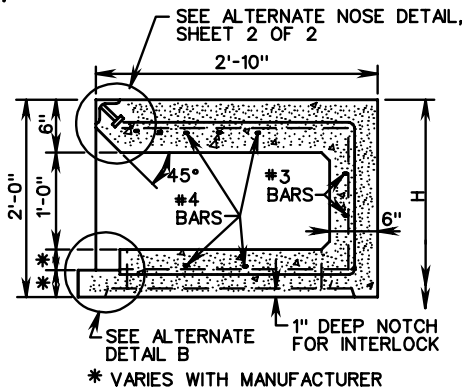

**NOTES:**

1. SEE GENERAL NOTES - PRECAST FOR ADDITIONAL DETAILS.
2. CONCRETE TO BE 4000 PSI MINIMUM COMPRESSIVE STRENGTH.
3. REINFORCING STEEL IN ACCORDANCE WITH ASTM A-615 FOR REINFORCING BARS.
4. REINFORCING IN ACCORDANCE WITH ASTM A-185 FOR WELDED WIRE MESH.
5. DIMENSIONS SHOWN ARE MINIMUM. ACTUAL DIMENSIONS MAY VARY WITH MANUFACTURER.
6. THIS UNIT MAY BE USED WITH ALL STANDARD DI-3 & DI-4 CURB DROP INLETS.
7. EACH FACE BLOCK SHALL HAVE 2 OR MORE LOOPS (#3 BARS) CAST IN FACE AS SHOWN. THESE LOOPS MAY BE USED FOR LIFT, AND FOR TIEING IN THE POURED IN PLACE GUTTER SECTION. FACE BLOCKS ARE TO BE SEALED WITH GROUT OR POLYSULFIDE SEALER.
8. STANDARD ST-1 STEPS NOT REQUIRED IN THIS TOP UNIT.

**RECOMMENDED MINIMUM HEIGHT CHART**

DI-3A,B,C, FOR 36" I.D. BASE UNIT	PIPE SIZE	H DIMENSION CONCRETE PIPE
	6"	2'-11"
8"	3'-1 1/4"	
10"	3'-3 3/4"	
12"	3'-6"	
15"	3'-9 1/4"	
18"	4'-0 1/2"	
21"	4'-3 3/4"	
DI-3A,B,C,D,E,&F FOR 48" I.D. BASE UNIT	6"	3'-9"
	8"	3'-11 1/4"
	10"	4'-1 1/4"
	12"	4'-4"
	15"	4'-7 1/4"
	18"	4'-10 1/2"
	21"	5'-1 3/4"
24"	5'-5"	
27"	5'-8 1/4"	
DI-3A,B,C,D,E,&F FOR 60" OR 72" I.D. BASE UNITS & DI-4A,B,C,D,E,&F	12"	4'-4"
	15"	4'-7 1/4"
	18"	4'-10 1/2"
	21"	5'-1 3/4"
	24"	5'-5"
	27"	5'-8 1/4"
	30"	6'-2 3/4"
	33"	6'-5 3/4"
	36"	6'-9"
	42"	7'-3 1/2"
48"	7'-10"	



ROAD AND BRIDGE STANDARDS

SHEET 1 OF 2

REVISION DATE

103.05

**STANDARD PRECAST TOP UNITS**

VIRGINIA DEPARTMENT OF TRANSPORTATION

SPECIFICATION REFERENCE

105  
233  
302