

**DETAIL OF TRANSVERSE CONTRACTION JOINT**  
(BEFORE INSTALLATION OF SEAL)

**GENERAL NOTES**

ALTERNATE PREFORMED SEALANTS HAVING A CROSS-SECTIONAL AREA COMPARABLE TO TYPE A (CONTRACTION JOINTS) AND TYPE D (EXPANSION JOINTS) AND MEETING THE APPROVAL OF THE ENGINEER MAY BE SUBSTITUTED.

OTHER TYPES OF JOINT MATERIAL ARE TO BE IN ACCORDANCE WITH THE SPECIFICATIONS.

ALL DETAILS NOT SHOWN HEREON TO BE IN ACCORDANCE WITH STANDARDS PR-2, SHEET 2 OF 5.

ALL CONTRACTION JOINTS TO BE SAWED IN CONFORMANCE WITH DETAIL TO THE LEFT, EXCEPT THAT WHERE GRAVEL AGGREGATE IS USED IN THE CONCRETE, THE JOINT MAY BE PREPARED BY FORMING 1/4" OR LESS OF THE WIDTH, FOR THE DEPTH SHOWN WITH NON-METALLIC OR REMOVABLE MATERIAL, FOLLOWED BY SAWING TO COMPLETE THE JOINT TO THE REQUIRED WIDTH AND DEPTH.

FOR DETAILS OF TRANSVERSE CONSTRUCTION JOINT, SEE BELOW.

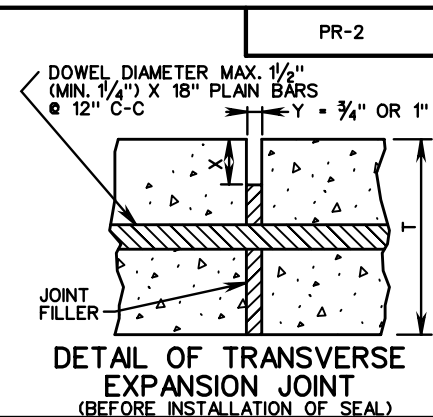

**DETAIL OF TRANSVERSE EXPANSION JOINT**  
(BEFORE INSTALLATION OF SEAL)

**PREFORMED CHLOROPRENE ELASTOMERIC JOINT SEALANT**

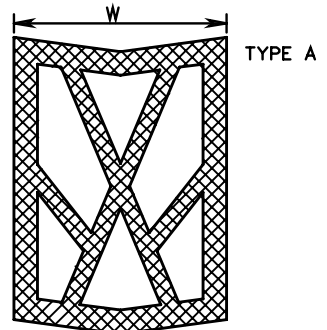

**SEALANTS FOR TRANSVERSE CONTRACTION JOINTS**

**SILICONE JOINT SEALANT**

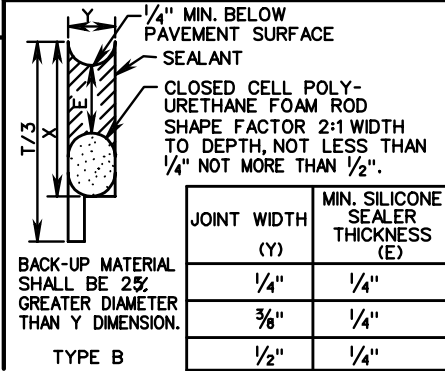

**SEALANTS FOR TRANSVERSE CONTRACTION JOINTS**

**SILICONE JOINT SEALANT**

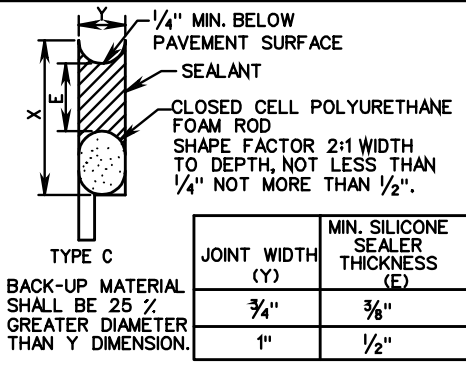

**SEALANTS FOR TRANSVERSE EXPANSION JOINTS**

**PREFORMED CHLOROPRENE ELASTOMERIC JOINT SEALANT**

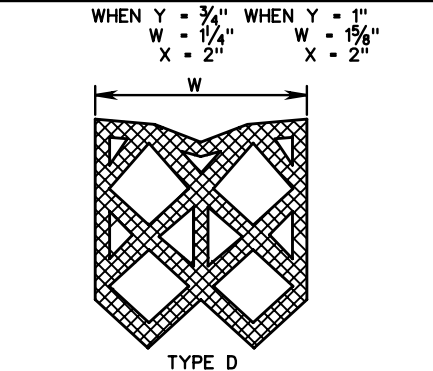

**SEALANTS FOR TRANSVERSE EXPANSION JOINTS**

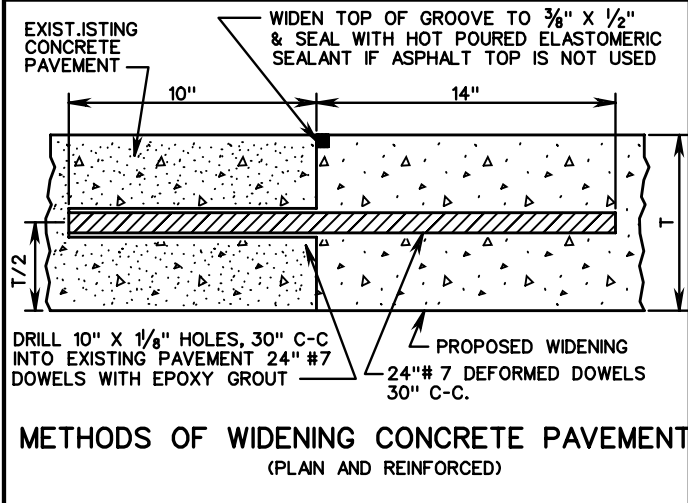

**METHODS OF WIDENING CONCRETE PAVEMENT**  
(PLAIN AND REINFORCED)

FOR 15' SLAB LENGTHS (PLAIN)				
DIMENSION	SEALANT TYPE			
	A	B	C	D
X	1 3/4"	1/4"	1 3/4" - 2"	2"
Y	1/4"	1/4"	3/4" OR 1"	3/4" OR 1"
W	5/8" ± 1/16"	-	-	-

FOR 30' SLAB LENGTHS (REINFORCED)				
DIMENSION	SEALANT TYPE			
	A	B	C	D
X	1 3/4"	1/4"	1 3/4" OR 2"	2"
Y	3/8"	3/8"	3/4" OR 1"	3/4" OR 1"
W	1/4" ± 1/16"	-	-	-

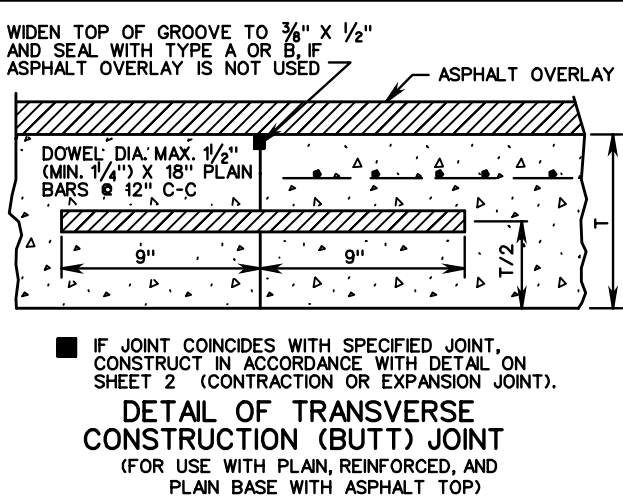

**DETAIL OF TRANSVERSE CONSTRUCTION (BUTT) JOINT**  
(FOR USE WITH PLAIN, REINFORCED, AND PLAIN BASE WITH ASPHALT TOP)

SPECIFICATION REFERENCE
316

**PLAIN AND REINFORCED CONCRETE PAVEMENT**  
SHOWING REINFORCEMENT, LONGITUDINAL AND TRANSVERSE JOINTS

VIRGINIA DEPARTMENT OF TRANSPORTATION

<b>VDOT</b>	
ROAD AND BRIDGE STANDARDS	
REVISION DATE	SHEET 3 OF 5
301.03	