

TYPE R

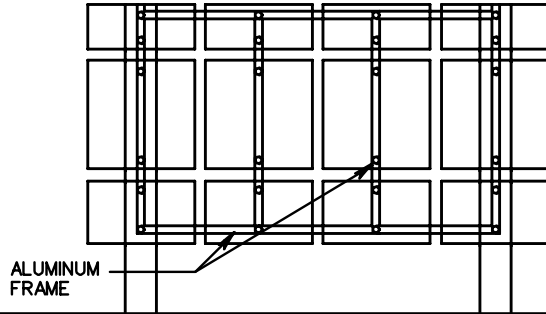

TYPE S

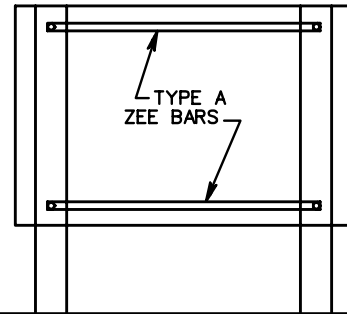

TYPE T

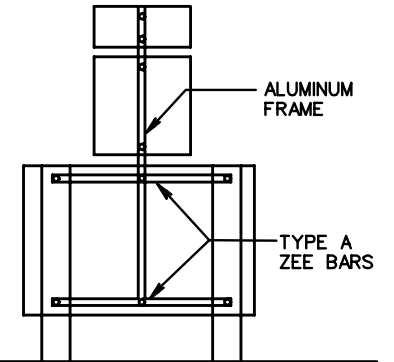

TYPE U

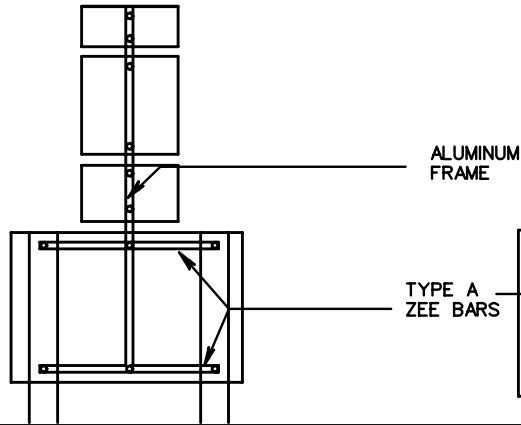

TYPE V

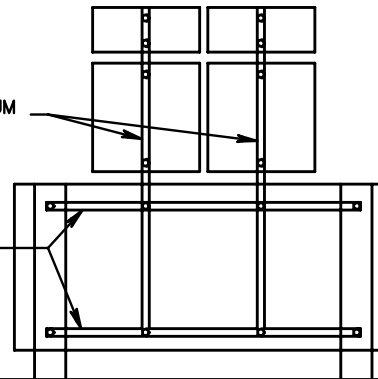

TYPE W

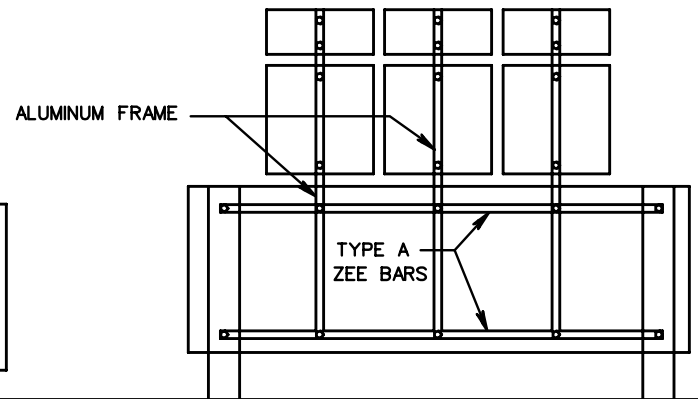

ALUMINUM FRAMING

SIGN PANEL ATTACHMENT DETAILS

(FOR SIGN PANEL ATTACHMENT TO Z BARS, SEE STANDARD SPD-1)

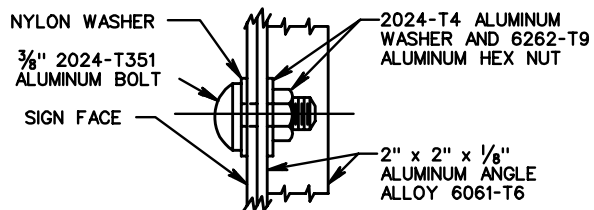

NOTES

NYLON WASHER SHALL BE 1/8" THICK MINIMUM WITH AN OUTSIDE DIAMETER OF 1" AND AN INSIDE DIAMETER OF 7/16".

TO OBTAIN A FLUSH MOUNTING SURFACE FOR SIGNS, ALL WOOD POST SHALL BE MORTISED WHERE NECESSARY TO RELIEVE FLANGE OF ALUMINUM ANGLE.

THE TYPE A ZEE BARS SHALL BE 2 3/8" X 1/4" X 3/16".

ALL VERTICAL AND HORIZONTAL SPACING BETWEEN SIGNS IN AN ASSEMBLY SHALL BE ONE INCH UNLESS SPECIFIED.

THESE ARE TYPICAL SIGN PANEL ASSEMBLIES; ALL ASSEMBLIES SHALL BE IN ACCORDANCE WITH PLAN DETAILS.

SPECIFICATION REFERENCE

701

SIGN PANEL DESIGN

VIRGINIA DEPARTMENT OF TRANSPORTATION

VDOT

ROAD AND BRIDGE STANDARDS

REVISION DATE SHEET 2 OF 2

1325.51