

NOTES:

ALL CIRCUIT BREAKERS SHALL BE SINGLE POLE.
 VOLTAGE AND AMPERAGE RATING OF CONTACTORS
 AND BREAKERS SHALL BE AS INDICATED ON THE PLANS.

NUMBER OF CIRCUITS SHOWN ARE TYPICAL. EXACT
 NUMBER REQUIRED SHALL BE AS INDICATED ON THE PLANS.

* CONTACTORS SHALL BE 2 POLES FOR SINGLE
 PHASE AND 3 POLES FOR THREE PHASE SERVICES.
 NUMBER OF CONTACTORS SHALL BE AS REQUIRED TO
 HANDLE THE NUMBER OF CIRCUITS ACTUALLY BEING UTILIZED.

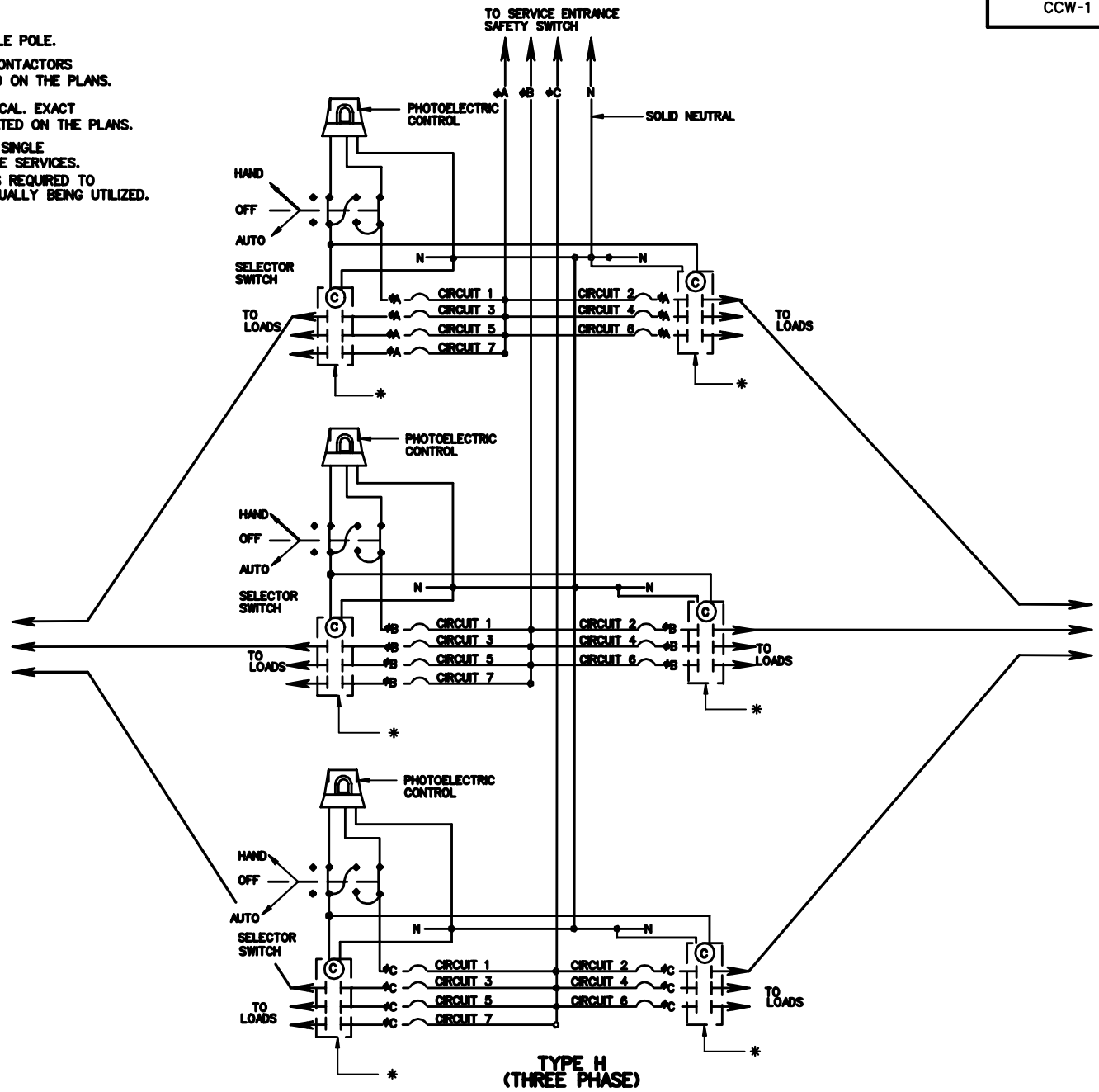

SPECIFICATION
 REFERENCE

700
 705

CONTROL CENTER WIRING DETAILS

VIRGINIA DEPARTMENT OF TRANSPORTATION

VDOT

ROAD AND BRIDGE STANDARDS

REVISION DATE

SHEET 4 OF 4

1314.13