

COMMONWEALTH OF VIRGINIA



2008

ROAD AND BRIDGE STANDARDS

VOLUME I

LOCATION AND DESIGN DIVISION

PROCEDURAL MEMORANDUM

GENERAL SUBJECT: Standard Drawings	NUMBER: N/A
SPECIFIC SUBJECT: 2008 Road & Bridge Standards	DATE: August 4, 2015
APPROVED: B. A. Thrasher, P.E. State Location and Design Engineer Approved <u>August 4, 2015</u>	SUPERSEDES: N/A

EFFECTIVE DATE

Effective December 2008, required to be used on all VDOT projects beginning with the June 2009 advertisement

PURPOSE

Provides standard drawings to be used on VDOT projects and for roadway construction within the right of way of the Commonwealth of Virginia.

ROAD AND BRIDGE STANDARDS

VOLUME I



VIRGINIA DEPARTMENT OF TRANSPORTATION

SPECIFICATION REFERENCES NOTED
THROUGHOUT ARE BASED ON VIRGINIA
DEPARTMENT OF TRANSPORTATION
ROAD AND BRIDGE SPECIFICATIONS
DATED 2007.

Copyright 2008 Commonwealth of Virginia

RECOMMENDED

FOR APPROVAL Mohammed Mirshahi
DIVISION ADMINISTRATOR

APPROVED Malcolm Kerley
CHIEF ENGINEER

**SECTION 100
DRAINAGE**

<u>ITEMS</u>	<u>SERIES</u>
ENDWALLS.....	101
END SECTIONS.....	102
PRECAST UNITS.....	103
DROP INLETS.....	104
INLET COVERS.....	105
MANHOLE COVERS, PRECAST MANHOLES, JUNCTION BOXES.....	106
PIPE, PIPE COVER TABLES, PIPE INSTALLATION.....	107
UNDERDRAIN, EDGEDRAIN.....	108
PAVED DITCHES.....	109
SPRING BOX.....	110
ENERGY DISSIPATORS.....	111
PIPE SPILLOUT.....	112
TEMP DIVERSION CHANNEL, EROSION CONTROL.....	113
STORMWATER MANAGEMENT.....	114

**SECTION 200
CURBS & ENTRANCES**

<u>ITEMS</u>	<u>SERIES</u>
CURB AND COMBINATION CURB AND GUTTER.....	201
MEDIAN CURB AND RAISED MEDIAN STRIP.....	202
ENTRANCES, CURB RAMPS, DETECTABLE WARNING SURFACE.....	203

**SECTION 300
PAVEMENT**

<u>ITEMS</u>	<u>SERIES</u>
REINFORCED CONCRETE PAVEMENT.....	301
BRIDGE APPROACH EXPANSION JOINT.....	302
METHOD OF WIDENING BRIDGE APPROACH PAVEMENT.....	303
RUMBLE STRIPS.....	304

**SECTION 400
RETAINING WALLS**

<u>ITEMS</u>	<u>SERIES</u>
RETAINING WALLS.....	401

**SECTION 500
GUARDRAIL & FENCE**

<u>ITEMS</u>	<u>SERIES</u>
GUARDRAIL.....	501
MEDIAN BARRIER.....	502
FENCING.....	503
RIGHT OF WAY MONUMENTS.....	504

**SECTION 600
MISC. & TABLES**

<u>ITEMS</u>	<u>SERIES</u>
CONCRETE STEPS, HAND RAIL, BOAT LAUNCHING RAMPS, AND SETTLEMENT PLATE.....	601
SIGN ISLANDS, PRIVATE ENTRANCES, MAINTENANCE CROSSOVERS.....	602
MAILBOX AND TURNOUT DETAIL.....	603
PRECAST CATTLE GUARD.....	604
STORAGE FACILITY FOR NUCLEAR GAUGE.....	605
UNDERCUTTING ROCK.....	606
SETTING AND MARKING SLOPE STAKES.....	607
SIGHT DISTANCES ON HORIZONTAL CURVES.....	608

**SECTION 700
GEOMETRIC DESIGN**

<u>ITEMS</u>	<u>SERIES</u>
METHODS OF GRADING SIDESLOPES.....	701
SHOULDER DESIGNS.....	702

**SECTION 800
TRANSITION CURVES**

<u>ITEMS</u>	<u>SERIES</u>
TRANSITION CURVES TC-5.01.....	802

APPENDIX

<u>ITEMS</u>	<u>SERIES</u>
CONVERSION TABLES, STANDARD REINFORCING BARS.....	A
PARABOLIC VERTICAL CURVE COMPUTATIONS & METRIC CONVERSION FACTORS	

**TABLE OF CONTENTS
VOLUME I**

SECTION 100

DRAINAGE ITEMS

THIS PAGE INTENTIONALLY LEFT BLANK



ROAD AND BRIDGE STANDARDS

SHEET 1 OF 1

REVISION DATE

SPECIFICATION
REFERENCE

VIRGINIA DEPARTMENT OF TRANSPORTATION

STANDARD	TITLE	PAGE
EW-1, 1A	STANDARD ENDWALL FOR PIPE CULVERTS 12" - 36" CIRCULAR AND 23" X 14" - 53" X 34" ELLIPTICAL PIPES	101.01
EW-1PC, 1APC	PRECAST ENDWALL FOR PIPE CULVERTS 12" - 36" CIRCULAR AND 23" X 14" - 53" X 34" ELLIPTICAL PIPES	101.02
EW-2, 2A	STANDARD ENDWALL FOR PIPE CULVERTS 42" - 96" CIRCULAR AND 60" X 38" - 106" X 68" ELLIPTICAL PIPES	101.03
	STANDARD ENDWALL FOR PIPE CULVERTS 42" - 96" CIRCULAR	101.04
	STANDARD ENDWALL FOR PIPE CULVERTS 60" X 38" - 106" X 68" ELLIPTICAL PIPES	101.05
EW-2PC	PRECAST ENDWALL FOR 42" - 96" CIRCULAR PIPE CULVERTS	101.06
EW-2APC	PRECAST ENDWALL FOR 60" X 38" - 106" X 68" ELLIPTICAL PIPE CULVERTS	101.07
EW-2S	STANDARD ENDWALLS FOR 42" - 96" PIPE CULVERTS 30 AND 45 DEGREE SKEWS	101.08
	STANDARD ENDWALLS FOR 42" - 96" PIPE CULVERTS 30 AND 45 DEGREE SKEWS	101.09
EW-2SPC	PRECAST ENDWALLS FOR PIPE CULVERTS 42" - 96" PIPE 30 AND 45 DEGREE SKEW	101.10
EW-6	ENDWALL FOR MULTIPLE PIPE CULVERTS 12" - 36" PIPES	101.11
EW-6PC	PRECAST ENDWALLS FOR MULTIPLE PIPE CULVERTS 12" - 36" PIPE	101.12
EW-6S	ENDWALLS FOR MULTIPLE PIPE CULVERTS 12" - 36" PIPE 30 DEGREE SKEW	101.13
	ENDWALLS FOR MULTIPLE PIPE CULVERTS 12" - 36" PIPE 45 DEGREE SKEW	101.14
EW-6SPC	PRECAST ENDWALLS FOR MULTIPLE PIPE CULVERTS 12" - 36" PIPE 30 DEGREE SKEW	101.15
	PRECAST ENDWALLS FOR MULTIPLE PIPE CULVERTS 12" - 36" PIPE 45 DEGREE SKEW	101.16
EW-7	ENDWALLS FOR MULTIPLE PIPE CULVERTS 42" - 96" PIPE	101.17
EW-7PC	PRECAST ENDWALLS FOR MULTIPLE PIPE CULVERTS 42" - 96" PIPE	101.18
EW-7S	ENDWALLS FOR MULTIPLE PIPE CULVERTS 42" - 96" PIPE 30 DEGREE SKEW	101.19
	ENDWALLS FOR MULTIPLE PIPE CULVERTS 42" - 96" PIPE 45 DEGREE SKEW	101.20
EW-7S PC	PRECAST ENDWALLS FOR MULTIPLE PIPE CULVERTS 42" - 96" PIPE 45 DEGREE SKEW	101.21
EW-9	ENDWALLS FOR PIPE ARCHES 13" - 38" RISE	101.22
EW-9PC	PRECAST ENDWALLS FOR PIPE ARCHES 13" - 38" RISE	101.23
EW-10	ENDWALLS FOR MULTIPLE PIPE ARCHES 13" - 38" RISE	101.24
EW-10PC	PRECAST ENDWALLS FOR MULTIPLE PIPE ARCHES 13" - 38" RISE	101.25
EW-11	PIPE ENDWALL WITH LOAD-CARRYING GRATE FOR 12" - 60" PIPES	101.26
	PIPE ENDWALL WITH LOAD-CARRYING GRATE FOR 12" - 60" PIPES	101.27
	PIPE ENDWALL WITH LOAD-CARRYING GRATE FOR 12" - 60" PIPES	101.28
EW-11A	PIPE ENDWALL WITH LOAD-CARRYING GRATE FOR 12" - 24" PIPES	101.29
	PIPE ENDWALL WITH LOAD-CARRYING GRATE FOR 12" - 24" PIPES	101.30
EW-11APC	PRECAST PIPE ENDWALL WITH LOAD-CARRYING GRATE FOR 12" - 24" PIPES	101.31
EW-12	ENDWALL FOR PIPE UNDERDRAIN	101.32

INDEX OF SHEETS
SECTION 100-DRAINAGE

VIRGINIA DEPARTMENT OF TRANSPORTATION



ROAD AND BRIDGE STANDARDS

REVISION DATE

SHEET 1 OF 6

100.01

STANDARD	TITLE	PAGE
ES-1	FLARED END-SECTION FOR 12" TO 60" CONCRETE PIPE CULVERTS	102.01
ES-1A	FLARED END-SECTION FOR 23" X 14" TO 53" X 34" ELLIPTICAL CONCRETE PIPE CULVERTS	102.02
ES-2	FLARED END-SECTION FOR 12" - 60" CORRUGATED PIPE CULVERTS	102.03
ES-3	FLARED END-SECTION FOR METAL PIPE ARCHES 13"- 47" RISE	102.04
	PRECAST UNIT ASSEMBLY DIAGRAM	103.01
	LEGEND AND GENERAL NOTES - PRECAST	103.02
T-DI-1	STANDARD PRECAST TOP UNITS	103.03
T-DI-2	STANDARD PRECAST TOP UNITS	103.04
T-DI-3, 4	STANDARD PRECAST TOP UNITS	103.05
	STANDARD PRECAST TOP UNITS	103.06
T-DI-5	STANDARD PRECAST TOP UNITS	103.07
T-DI-7	STANDARD PRECAST TOP UNITS	103.08
T-MH-2	STANDARD PRECAST MANHOLE TOP UNITS	103.09
R-1, 2, 3	STANDARD PRECAST REDUCER AND RISER UNITS	103.10
B-1, 2	STANDARD PRECAST BASE UNITS	103.11
B-3	STANDARD PRECAST BASE UNITS MAX. DEPTH (H) 25'	103.12
B-4	CORRUGATED METAL TEE SECTION MAX. DEPTH (H) 25'	103.13
DI-1	STANDARD DROP INLET 12" - 24" PIPE: MAXIMUM DEPTH (H) =10'	104.01
DI-1A	STANDARD DROP INLET 12" - 24" PIPE: MAXIMUM DEPTH (H) 10' TO 20'	104.02
DI-2A, 2B, 2C	STANDARD CURB DROP INLET 12" - 24" PIPE: MAXIMUM DEPTH (H) =9'	104.03
	DIMENSIONS, NOTES, AND QUANTITIES	104.04
DI-2AA, 2BB, 2CC	STANDARD CURB DROP INLET 12" - 24" PIPE: DEPTH (H) 9' TO 20'	104.05
DI-2D, 2E, 2F	STANDARD CURB DROP INLET 30" - 48" PIPE: MAXIMUM DEPTH (H) =9'	104.06
	DIMENSIONS, NOTES, AND QUANTITIES	104.07
DI-2DD, 2EE, 2FF	STANDARD CURB DROP INLET 30" - 48" PIPE: DEPTH (H) =9' TO 20'	104.08
DI-3A, 3B, 3C	STANDARD CURB DROP INLET 12" - 30" PIPE: MAXIMUM DEPTH (H) =8'	104.09
	DIMENSIONS, NOTES, AND QUANTITIES	104.10
DI-3AA, 3BB, 3CC	STANDARD DROP INLET 12" - 30" PIPE: MAXIMUM DEPTH (H) 8' TO 20'	104.11
DI-3D, 3E, 3F	STANDARD DROP INLET (WITH UTILITY SPACE) 12" - 30" PIPE: MAXIMUM DEPTH (H) =8'	104.12
	DIMENSIONS, NOTES, AND QUANTITIES	104.13
DI-3DD, 3EE, 3FF	STANDARD CURB DROP INLET (WITH UTILITY SPACE) 12" - 30" PIPE: DEPTH (H) =8' TO 20'	104.14



ROAD AND BRIDGE STANDARDS

SHEET 2 OF 6

REVISION DATE

100.02

INDEX OF SHEETS SECTION 100-DRAINAGE

VIRGINIA DEPARTMENT OF TRANSPORTATION

STANDARD	TITLE	PAGE
DI-4A, 4B, 4C	STANDARD CURB DROP INLET 36" - 48" PIPE: MAXIMUM DEPTH (H)=8'	104.15
	DIMENSIONS, NOTES, AND QUANTITIES	104.16
DI-4AA, 4BB, 4CC	STANDARD CURB DROP INLET 36" - 48" PIPE: DEPTH (H) 8' TO 20'	104.17
DI-4D, 4E, 4F	STANDARD CURB DROP INLET (WITH UTILITY SPACE) 36" - 48" PIPE: MAXIMUM DEPTH (H) 8'	104.18
	DIMENSIONS, NOTES, AND QUANTITIES	104.19
DI-4DD, 4EE, 4FF	STANDARD CURB DROP INLET (WITH UTILITY SPACE) 36" - 48" PIPE: DEPTH (H) 8' TO 16'	104.20
DI-5	STANDARD DITCH DROP INLET	104.21
DI-7, 7A, 7B	STANDARD MEDIAN DROP INLET 12" - 42" PIPE	104.22
	COVER AND GUTTER DETAILS	104.23
DI-7, 7A, 7B	STANDARD DI-7, 7A OR 7B WITH FLUME CONNECTION 12" TO 36" PIPE	104.24
DI-9	15" PIPE TEE SECTION DROP INLET	104.25
DI-10G, 10H, 10I	CONCRETE MEDIAN BARRIER DROP INLET (WITH MB-7D) 12" TO 36" PIPE: DEPTH (H)=20' MAX.	104.26
	DIMENSIONS, NOTES, AND QUANTITIES	104.27
DI-10J, 10K, 10L	CONCRETE MEDIAN BARRIER DROP INLET (WITH MB-8A) 12" TO 24" PIPE: DEPTH (H)=20' MAX.	104.28
	DIMENSIONS, NOTES, AND QUANTITIES	104.29
DI-12, 12A	MULTIGRATE DROP INLET FOR PIPE SIZES 12" - 72"	104.30
	GRATE DETAILS	104.31
	DIMENSIONS, NOTES, AND QUANTITIES	104.32
DI-12B, 12C	MULTIGRATE DROP INLET FOR PIPE SIZES 12" - 36"	104.33
	GRATE DETAILS AND QUANTITIES	104.34
DI-13	SHOULDER SLOT INLET	104.35
	SHOULDER SLOT INLET	104.36
PI-1	METHOD OF OUTLET PIPE INSTALLATION FOR DI-13	104.37
DI-14A, 14B, 14C	CONCRETE MEDIAN BARRIER DROP INLET (TALL WALL WITH MB-12) 12" - 36" PIPE: DEPTH (H)=20'-0" MAX.	104.38
	DIMENSIONS, NOTES, AND QUANTITIES	104.39
DI-14D, 14E, 14F	CONCRETE MEDIAN BARRIER DROP INLET (TALL WALL WITH MB-13) 12" - 24" PIPE: DEPTH (H)=20'-0" MAX.	104.40
	CONCRETE MEDIAN BARRIER DROP INLET (TALL WALL WITH MB-13) 12" - 24" PIPE: DEPTH (H)=20'-0" MAX.	104.41
DI-MB	CONSTRUCTION METHOD FOR CONCRETE MASONRY BLOCK CURB DROP INLET	104.42
IC-2	STANDARD INLET FRAME AND COVER	105.01
	STANDARD INLET FRAME AND COVER	105.02
	PRECAST INLET FRAME AND COVER	105.03

INDEX OF SHEETS SECTION 100-DRAINAGE

VIRGINIA DEPARTMENT OF TRANSPORTATION



ROAD AND BRIDGE STANDARDS

REVISION DATE	SHEET 3 OF 6
---------------	--------------

100.03

STANDARD	TITLE	PAGE
MH-1	MANHOLE FOR 12" TO 48" PIPE CULVERT	106.01
	STANDARD MANHOLE FRAME AND COVER	106.02
	STANDARD MANHOLE FRAME AND COVER	106.03
	STANDARD MANHOLE FRAME AND COVER	106.04
	STANDARD MANHOLE FRAME AND COVER	106.05
MH-1A	STANDARD MANHOLE FRAME AND COVER	106.06
MH-2	PRECAST MANHOLE	106.07
IS-1	METHOD OF SHAPING MANHOLE AND INLET CULVERTS	106.08
ST-1	STANDARD STEP	106.09
JB-1	JUNCTION BOX CHAMBER DETAILS FOR 48" - 72" PIPE CULVERTS	106.10
	JUNCTION BOX DETAILS FOR ANGULAR CONNECTIONS OF 48" - 72" PIPE CULVERTS	106.11
	JUNCTION BOX TOWER DETAILS FOR 48" - 72" PIPE CULVERTS	106.12
	JUNCTION BOX DISPLACEMENT QUANTITIES FOR 48" - 72" PIPE CULVERTS	106.13
SL-1	TYPICAL CONCRETE SAFETY SLAB FOR DROP INLETS, MANHOLES AND JUNCTION BOXES	106.14
DSB-1	DRAINAGE STRUCTURE BEDDING FOR DROP INLETS, MANHOLES, AND JUNCTION BOXES	106.15
PB-1	INSTALLATION OF PIPE CULVERTS AND STORM SEWERS	107.00
	INSTALLATION OF PIPE CULVERTS AND STORM SEWERS CIRCULAR PIPE BEDDING AND BACKFILL - METHOD "A"	107.01
	INSTALLATION OF PIPE CULVERTS AND STORM SEWERS ELLIPTICAL PIPE BEDDING AND BACKFILL - METHOD "A"	107.02
	INSTALLATION OF PIPE CULVERTS AND STORM SEWERS PIPE ARCH BEDDING AND BACKFILL	107.03
	INSTALLATION OF BOX CULVERTS BEDDING AND BACKFILL	107.04
PC-1	CONCRETE PIPE - CLASS TABLE FOR HL-93 LIVE LOAD	107.05
	ELLIPTICAL CONCRETE PIPE - TABLE FOR HL-93 LIVE LOAD	107.06
	CORRUGATED STEEL PIPE - HEIGHT OF COVER TABLE FOR HL-93 LIVE LOAD	107.07
	CORRUGATED ALUMINUM ALLOY PIPE - HEIGHT OF COVER TABLE FOR HL-93 LIVE LOAD	107.08
	CORRUGATED STEEL PIPE ARCH - HEIGHT OF COVER TABLE FOR HL-93 LIVE LOAD	107.09
	CORRUGATED ALUMINUM ALLOY PIPE ARCH - HEIGHT OF COVER TABLE FOR HL-93 LIVE LOAD	107.10
	STRUCTURAL PLATE STEEL PIPE - HEIGHT OF COVER TABLE FOR HL-93 LIVE LOAD	107.11
	STRUCTURAL PLATE ALUMINUM ALLOY PIPE - HEIGHT OF COVER TABLE FOR HL-93 LIVE LOAD	107.12
	STRUCTURAL PLATE STEEL PIPE ARCH - HEIGHT OF COVER TABLE FOR HL-93 LIVE LOAD	107.13
	STRUCTURAL PLATE STEEL PIPE ARCH - HEIGHT OF COVER TABLE FOR HL-93 LIVE LOAD	107.14
	STRUCTURAL PLATE ALUMINUM ALLOY PIPE ARCH - HEIGHT OF COVER TABLE FOR HL-93 LIVE LOAD	107.15
	ALUMINUM SPIRAL RIB PIPE - HEIGHT OF COVER TABLE FOR HL-93 LIVE LOAD	107.16
	STEEL SPIRAL RIB PIPE - HEIGHT OF COVER TABLE FOR HL-93 LIVE LOAD	107.17
	CAST IRON PIPE - STRENGTH TABLE FOR HL-93 LIVE LOAD	107.18
	PLASTIC PIPE - MAXIMUM COVER TABLE FOR HL-93 LIVE LOAD	107.19
ALLOWABLE PIPE CRITERIA FOR CULVERTS AND STORM SEWERS	107.20	
ALLOWABLE PIPE CRITERIA FOR CULVERTS AND STORM SEWERS	107.21 & 107.22	



ROAD AND BRIDGE STANDARDS

SHEET 4 OF 6

REVISION DATE

100.04

11/15

INDEX OF SHEETS SECTION 100-DRAINAGE

VIRGINIA DEPARTMENT OF TRANSPORTATION

STANDARD	TITLE	PAGE
PP-1	DETAILS FOR BACKFILLING ABANDONED CULVERTS	107.23
UD-1	STANDARD GROUNDWATER UNDERDRAIN	108.01
UD-2	PIPE UNDERDRAIN FOR USE WITH RAISED GRASS MEDIAN STRIPS	108.02
UD-3	STANDARD SIDEWALK UNDERDRAIN	108.03
CD-1	STANDARD COMBINATION UNDERDRAINS (AT LOWER END OF CUTS)	108.04
CD-2	STANDARD COMBINATION UNDERDRAINS (AT GRADE SAGS AND BRIDGE APPROACHES)	108.05
UD-4	STANDARD PAVEMENT EDGEDRAIN	108.06
	STANDARD PAVEMENT EDGEDRAIN	108.07
UD-5	PREFABRICATED GEOCOMPOSITE RETROFIT PAVEMENT EDGEDRAIN	108.08
UD-7	STANDARD RETROFIT EDGEDRAIN	108.09
PG-2A	STANDARD PAVED DITCHES	109.01
PG-3	STANDARD RIPRAP AND SLOPE PROTECTION	109.02
PG-4	STANDARD PAVED FLUME FOR 12" - 24" PIPE CULVERTS	109.03
PG-5	STANDARD PAVED DITCHES	109.04
PG-6A, 6B	STANDARD PRECAST PAVED DITCHES	109.05
PG-7	DITCH FLUME CONNECTOR	109.06
SB-1	STANDARD SPRING BOX	110.01
SB-1 PC	PRECAST SPRING BOX	110.02
EG-1, 1A	STANDARD ENERGY DISSIPATOR FOR USE WITH PAVED FLUME	111.01
EG-1, 1A PC	PRECAST ENERGY DISSIPATOR	111.02
PS-2	STANDARD PIPE SPILLOUT FOR 12" - 18" PIPE CULVERTS	112.01
PS-3	STANDARD PIPE SPILLOUT FOR 21" - 30" PIPE CULVERTS	112.02
EC-1	CULVERT OUTLET PROTECTION	113.01
EC-2	PROTECTIVE COVERING INSTALLATION CRITERIA	113.02
EC-3	SOIL STABILIZATION MAT DITCH INSTALLATION TYPE A OR B	113.03
	SOIL STABILIZATION CULVERT OUTLET PROTECTION INSTALLATION	113.04
	SOIL STABILIZATION MAT SLOPE INSTALLATION TYPE C	113.05
EC-4	ROCK CHECK DAMS TYPE I AND II	113.06
EC-5	TEMPORARY SILT BARRIERS SILT FENCE (TYPE A & B) AND BRUSH BARRIER	113.07
	TEMPORARY SILT BARRIERS SILT FENCE (TYPE A & B) AND BRUSH BARRIER	113.07A
	TEMPORARY SILT BARRIERS SILT FENCE (TYPE A & B) AND BRUSH BARRIER	113.07B
	TEMPORARY SILT BARRIERS SILT FENCE (TYPE A & B) AND BRUSH BARRIER	113.08
EC-6	INLET PROTECTION (TYPE A AND B)	113.09
	INLET PROTECTION (TYPE C)	113.10

INDEX OF SHEETS SECTION 100-DRAINAGE

VIRGINIA DEPARTMENT OF TRANSPORTATION



ROAD AND BRIDGE STANDARDS

REVISION DATE

SHEET 5 OF 6

08/14

100.05

STANDARD	TITLE	PAGE
EC-7	TYPICAL SEDIMENT TRAP	113.11
EC-8	DEWATERING BASIN	113.12
EC-9	TEMPORARY DIVERSION DIKE	113.13
EC-10	TEMPORARY BERM AND SLOPE DRAIN	113.14
EC-11	STABILIZED CONSTRUCTION ENTRANCE	113.15
EC-12	TEMPORARY DIVERSION CHANNEL	113.16
EC-13	RIPRAP WEIRS; LOW FLOW DIVERSION FOR MULTIPLE LINE CULVERTS	113.17
EC-14	TEMPORARY VEHICULAR WATERCOURSE CROSSING	113.18
SWM-1	STORMWATER MANAGEMENT DRAINAGE STRUCTURE	114.01
	PRECAST STORMWATER MANAGEMENT DRAINAGE STRUCTURE	114.02
	STORMWATER MANAGEMENT DRAINAGE STRUCTURE - GRATE DETAILS	114.03
SWM-DR	STORMWATER MANAGEMENT (SWM) DETAILS	114.04
	STORMWATER MANAGEMENT (SWM) DETAILS	114.05
	STORMWATER MANAGEMENT (SWM) DETAILS	114.06
	STORMWATER MANAGEMENT (SWM) DETAILS	114.07
	STORMWATER MANAGEMENT (SWM) DETAILS	114.08



ROAD AND BRIDGE STANDARDS

SHEET 6 OF 6

REVISION DATE

100.06

04/09

INDEX OF SHEETS SECTION 100-DRAINAGE

VIRGINIA DEPARTMENT OF TRANSPORTATION

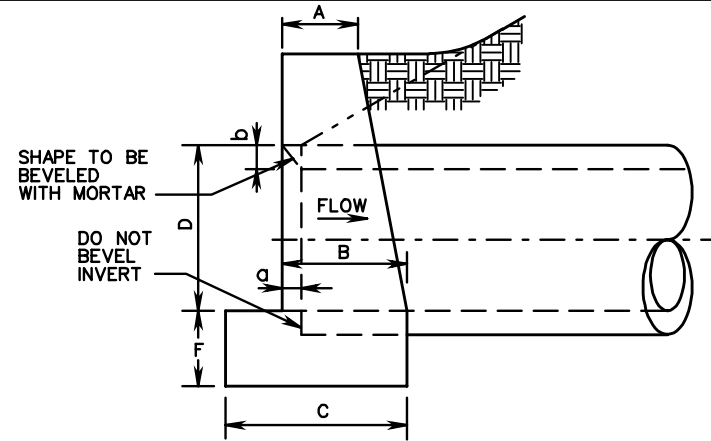
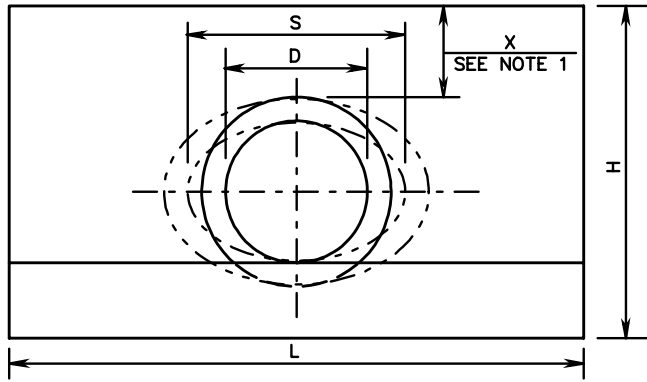

- NOTES:**
- "H" MAY BE REDUCED UNTIL "X" REACHES A MINIMUM OF 4" WHERE ENDWALL WOULD PROTRUDE ABOVE SHOULDER LINE. IN NO CASE SHALL TOP OF ENDWALL PROJECT ABOVE FILL SLOPE, DITCH SLOPE, OR SHOULDER.
 - THIS ITEM MAY BE PRECAST OR CAST IN PLACE.
 - ALL CAST IN PLACE CONCRETE TO BE CLASS A3. FOR PRECAST SEE SHEET 101.02.
 - THIS STANDARD TO BE USED WITH STRAIGHT CROSSINGS AND ALL SKEWS(0° TO 45°).
 - HEADWALL TO BE BEVELED IN ALL AREAS EXCEPT WHERE A CONFLICT WITH INVERT OR WINGWALLS OCCUR
 - BEVEL EDGE IS REQUIRED ON THE HEADWALL AT THE INLET END OF THE CULVERT (WHERE THE FLOW ENTERS THE CULVERT).
 - HEADWALL AT THE OUTLET END OF THE CULVERT MAY BE EITHER SQUARE EDGE OR BEVEL EDGE.
 - ON SHALLOW FILLS, WHERE ENDWALLS ARE 1' OR LESS BELOW SHOULDER LINE, THE TOP OF THE ENDWALL SHALL BE CONSTRUCTED PARALLEL TO THE GRADE OF THE ROAD.
 - 3/4" CHAMFER MAY BE PROVIDED ON ALL EDGES AT MANUFACTURER'S OPTION.

EW-1

ENDWALL FOR CIRCULAR PIPE

DIAMETER OF PIPE CULVERT						
	12"	15"	18"	21" OR 24"	27" OR 30"	33" OR 36"
A	0'-6"	0'-8"	0'-9"	0'-11"	1'-0"	1'-0"
B	0'-11"	1'-1"	1'-3"	1'-6"	1'-9"	2'-0"
C	1'-4"	1'-7"	1'-9"	2'-2"	2'-6"	2'-9"
D	1'-0"	1'-3"	1'-6"	2'-0"	2'-6"	3'-0"
F	0'-6"	0'-8"	0'-8"	0'-9"	0'-9"	0'-9"
H	2'-3"	2'-11"	3'-2"	3'-9"	4'-3"	4'-9"
L	4'-0"	5'-0"	6'-0"	8'-0"	10'-0"	12'-0"
a	0'-1 1/4"	0'-1 3/4"	0'-2"	0'-2 1/2"	0'-3 1/4"	0'-3 3/4"
b	0'-1"	0'-1 1/4"	0'-1 1/2"	0'-2"	0'-2 1/2"	0'-3"
CUBIC YARDS OF CONCRETE						
CONC. PIPE	0.241	0.492	0.697	1.319	2.067	2.947
C.M. PIPE	0.257	0.521	0.739	1.398	2.198	3.145

EW-1A

ENDWALL FOR ELLIPTICAL PIPE

SIZE OF ELLIPTICAL PIPE CULVERT (SPAN x RISE)								
	23"x14"	30"x19"	34"x22"	38"x24"	42"x27"	45"x29"	49"x32"	53"x34"
A	0'-8"	0'-9"	0'-10"	0'-11"	0'-11"	1'-0"	1'-0"	1'-0"
B	1'-2"	1'-5"	1'-6"	1'-8"	1'-9"	1'-10"	1'-11"	1'-11"
C	1'-8"	1'-11"	2'-1"	2'-4"	2'-5"	2'-7"	2'-8"	2'-9"
D	1'-2"	1'-7"	1'-10"	2'-0"	2'-3"	2'-5"	2'-8"	2'-10"
F	0'-8"	0'-8"	0'-9"	0'-9"	0'-9"	0'-9"	0'-9"	0'-9"
H	2'-10"	3'-3"	3'-7"	3'-9"	4'-0"	4'-2"	4'-5"	4'-7"
L	5'-5"	7'-2"	8'-6"	9'-2"	10'-2"	10'-11"	12'-1"	12'-11"
S	1'-11"	2'-6"	2'-10"	3'-2"	3'-6"	3'-9"	4'-1"	4'-5"
a	0'-2 1/2"	0'-3 1/4"	0'-3 1/2"	0'-4"	0'-4 1/2"	0'-4 3/4"	0'-5"	0'-5 1/2"
b	0'-2"	0'-2 1/2"	0'-2 3/4"	0'-3"	0'-3 1/2"	0'-3 3/4"	0'-4"	0'-4 1/2"
CUBIC YARDS OF CONCRETE								
CONC. PIPE	0.502	0.855	1.236	1.500	1.811	2.101	2.512	2.801

SPECIFICATION REFERENCE

105
302

STANDARD ENDWALL FOR PIPE CULVERTS
12" - 36" CIRCULAR AND 23" x 14" - 53" x 34" ELLIPTICAL PIPES

VIRGINIA DEPARTMENT OF TRANSPORTATION

VDOT

ROAD AND BRIDGE STANDARDS

REVISION DATE

SHEET 1 OF 1

101.01

EW-1, 1 APC

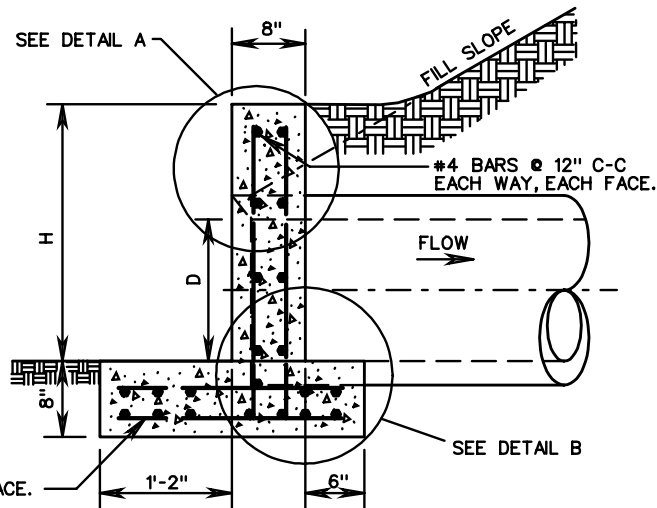
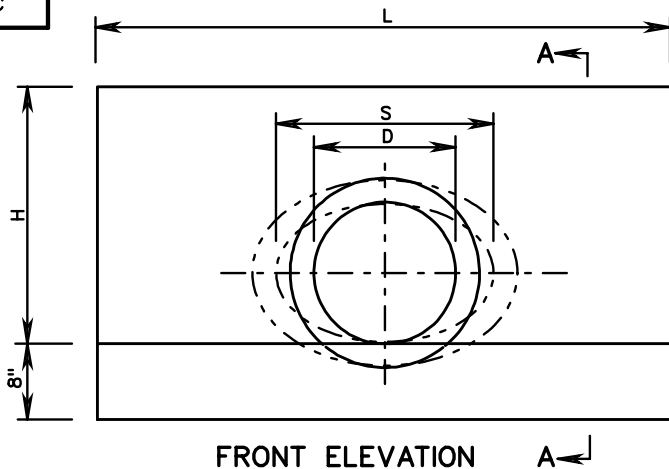

NOTES:

1. CONCRETE TO BE 4000 PSI MINIMUM COMPRESSIVE STRENGTH.
2. IF PIPE IS TO BE SKEWED THE OPENING WILL BE ADJUSTED TO ACCOMMODATE ANGLES UP TO 45°.
3. REINFORCING STEEL IN ACCORDANCE WITH ASTM A-615 (REINFORCING BARS).
4. PIPE OPENINGS IN PRECAST DRAINAGE UNITS SHALL NOT EXCEED 4 INCHES AT ANY GIVEN POINT BETWEEN THE PIPE AND THE PRECAST UNIT.
5. DIMENSIONS SHOWN ARE MINIMUM. ACTUAL MEASUREMENTS MAY VARY WITH MANUFACTURER'S TOLERANCE.
6. IN NO CASE SHALL TOP OF ENDWALL PROJECT ABOVE FILL SLOPE, DITCH SLOPE, OR SHOULDER.
7. HEADWALL TO BE BEVELED IN ALL AREAS EXCEPT WHERE A CONFLICT WITH INVERT OR WINGWALL OCCUR.
8. BEVEL EDGE IS REQUIRED ON THE HEADWALL AT THE INLET END OF THE CULVERT. HEADWALL AT OUTLET END MAY BE EITHER SQUARE EDGE OR BEVELED.
9. 3/4" CHAMFER MAY BE PROVIDED ON ALL EDGES AT MANUFACTURER'S OPTION.

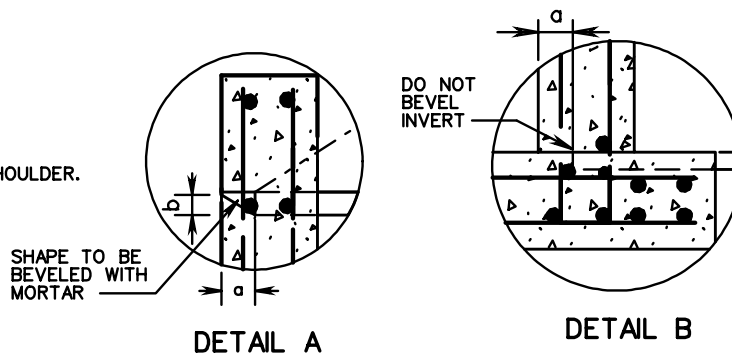

EW-1PC

ENDWALL FOR CIRCULAR PIPE						
DIAMETER OF PIPE CULVERT						
D	12"	15"	18"	21" OR 24"	27" OR 30"	33" OR 36"
H	2'-0"	2'-3"	2'-6"	3'-2"	3'-10"	4'-4"
L	4'-0"	5'-0"	6'-0"	8'-0"	10'-0"	12'-0"
a	0'-1 1/4"	0'-1 3/4"	0'-2"	0'-2 1/2"	0'-3 1/4"	0'-3 3/4"
b	0'-1"	0'-1 1/4"	0'-1 1/2"	0'-2"	0'-2 1/2"	0'-3"

EW-1APC

ENDWALL FOR ELLIPTICAL PIPE								
SIZE OF ELLIPTICAL PIPE CULVERT (SPAN x RISE)								
S x D	23" x 14"	30" x 19"	34" x 22"	38" x 24"	42" x 27"	45" x 29"	49" x 32"	53" x 34"
H	1'-10"	2'-4"	2'-7"	2'-9"	3'-1"	3'-3"	3'-6"	3'-8"
L	5'-5"	7'-2"	8'-6"	9'-2"	10'-2"	10'-11"	12'-1"	12'-11"
a	0'-2 1/2"	0'-3 1/4"	0'-3 1/2"	0'-4"	0'-4 1/2"	0'-4 3/4"	0'-5"	0'-5 1/2"
b	0'-2"	0'-2 1/2"	0'-2 3/4"	0'-3"	0'-3 1/2"	0'-3 3/4"	0'-4"	0'-4 1/2"



ROAD AND BRIDGE STANDARDS

SHEET 1 OF 1

REVISION DATE

101.02

PRECAST ENDWALL FOR PIPE CULVERTS

12" - 36" CIRCULAR AND 23" x 14" - 53" x 34" ELLIPTICAL PIPES

VIRGINIA DEPARTMENT OF TRANSPORTATION

SPECIFICATION REFERENCE

105
302

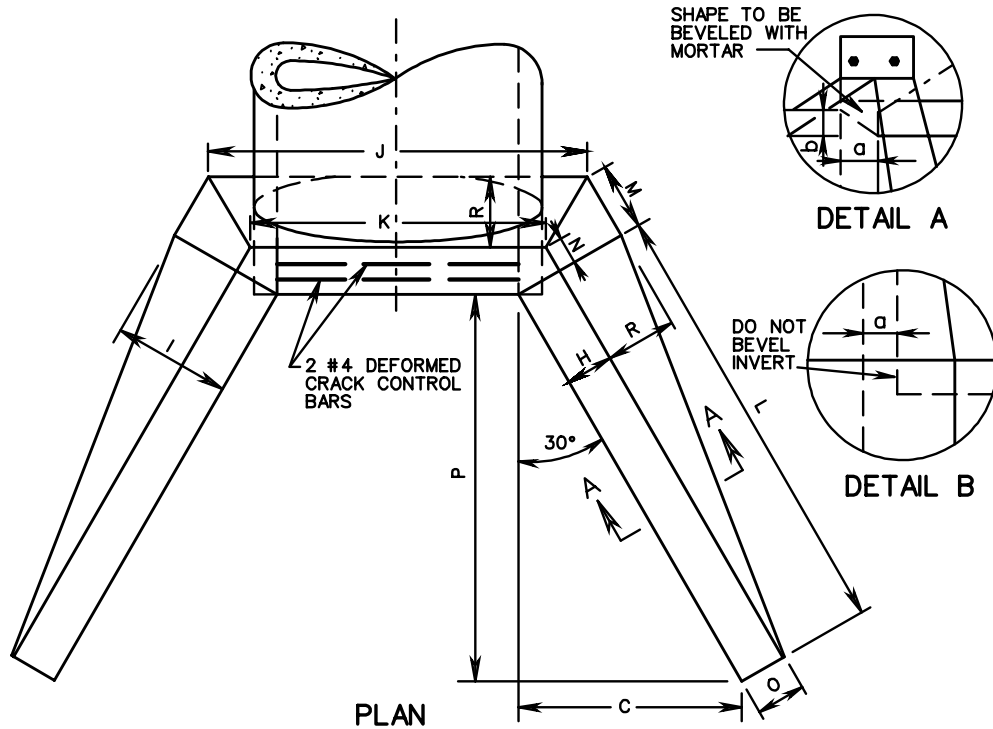

NOTES:

1. FOR TABLE OF DIMENSIONS AND VOLUMES FOR CIRCULAR PIPES (STANDARD EW-2) SEE SHEET 2 OF 3.
2. FOR TABLE OF DIMENSIONS AND VOLUMES FOR ELLIPTICAL PIPES (STANDARD EW-2A) SEE SHEET 3 OF 3.
3. THIS ITEM MAY BE PRECAST OR CAST IN PLACE.
4. ON SHALLOW FILLS, WHERE ENDWALLS ARE 1' OR LESS BELOW SHOULDER LINE, THE TOP OF THE ENDWALL SHALL BE CONSTRUCTED PARALLEL TO THE GRADE OF ROAD.
5. ALL CAST IN PLACE CONCRETE TO BE CLASS A3. FOR PRECAST SEE SHEETS 101.06 AND 101.07.
6. IN NO CASE SHALL TOP OF ENDWALL PROJECT ABOVE FILL SLOPE, DITCH SLOPE, OR SHOULDER.
7. THIS STANDARD TO BE USED WITH STRAIGHT CROSSINGS AND SKEW ANGLES TO 15°.
8. COST OF BARS FOR CRACK CONTROL TO BE INCLUDED IN PRICE PER BID PER CUBIC YARD CONCRETE.
9. HEADWALL TO BE BEVELED IN ALL AREAS EXCEPT WHERE A CONFLICT WITH INVERT AND WINGWALLS OCCUR.
10. BEVEL EDGE IS REQUIRED ON THE HEADWALL AT THE INLET END OF THE CULVERT (WHERE THE FLOW ENTERS THE CULVERT). HEADWALL AT THE OUTLET END OF THE CULVERT MAY BE EITHER SQUARE EDGE OR BEVEL EDGE.
11. 3/4" CHAMFER MAY BE PROVIDED ON ALL EDGES AT MANUFACTURER'S OPTION.

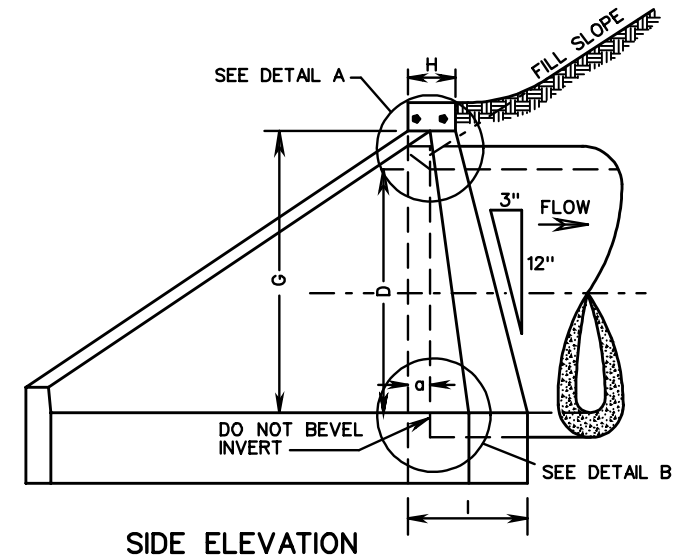
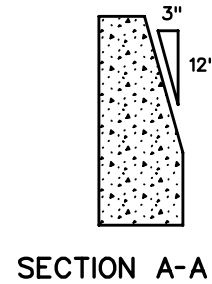
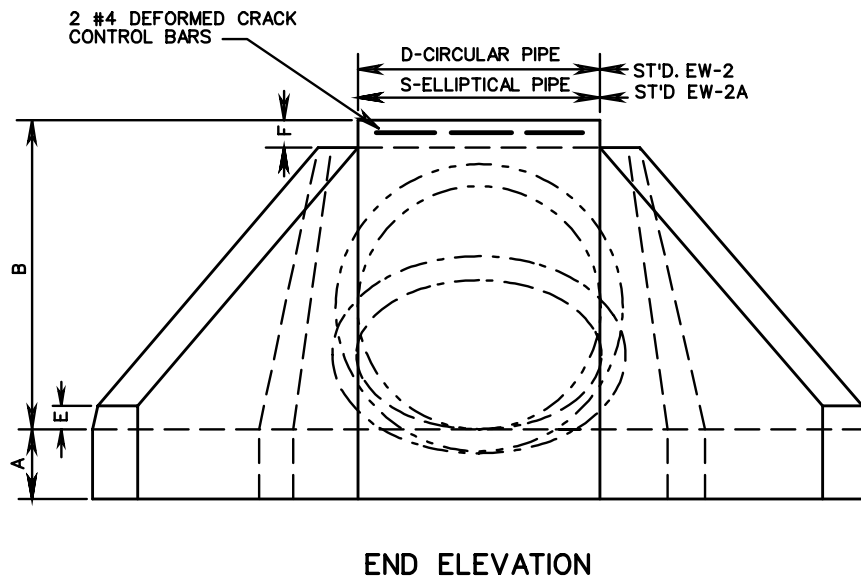

SPECIFICATION REFERENCE
105 302

STANDARD ENDWALL FOR PIPE CULVERTS
 42" - 96" CIRCULAR AND 60" x 38" - 108" x 68" ELLIPTICAL PIPES
 VIRGINIA DEPARTMENT OF TRANSPORTATION

VDOT	
ROAD AND BRIDGE STANDARDS	
REVISION DATE	SHEET 1 OF 3
	101.03

TABLE OF DIMENSIONS AND CONCRETE VOLUMES PER ENDWALL FOR 42" - 96" CIRCULAR PIPE CULVERTS

DIAMETER OF PIPE CULVERTS													
FOR 1/2:1 FILL SLOPE	DIMENSION	42"	48"	54"	60"	66"	72"	78"	84"	90"	96"	DIMENSION	
	A	1'-6"	1'-6"	1'-6"	1'-6"	1'-6"	1'-6"	1'-6"	1'-6"	1'-6"	1'-6"	1'-6"	A
	B	4'-9 1/2"	5'-4"	5'-10 1/2"	6'-5"	6'-11 1/2"	7'-6"	8'-0 1/2"	8'-7"	9'-2 1/4"	9'-9 3/4"	B	
	C	3'-3 3/4"	3'-9"	4'-2 1/4"	4'-7"	5'-0 5/8"	5'-5 3/4"	5'-11"	6'-4 1/4"	6'-9 3/8"	7'-2 5/8"	C	
	D	3'-6"	4'-0"	4'-6"	5'-0"	5'-6"	6'-0"	6'-6"	7'-0"	7'-6"	8'-0"	D	
	E	0'-6"	0'-6"	0'-6"	0'-6"	0'-6"	0'-6"	0'-6"	0'-6"	0'-6"	0'-6"	E	
	F	0'-5 1/2"	0'-6"	0'-6 1/2"	0'-7"	0'-7 1/2"	0'-8"	0'-8 1/2"	0'-9"	0'-9 1/2"	0'-10"	F	
	G	4'-4"	4'-10"	5'-4"	5'-10"	6'-4"	6'-10"	7'-4"	7'-10"	8'-4"	8'-10"	G	
	H	0'-10"	0'-10"	0'-11"	1'-0"	1'-1"	1'-2"	1'-3"	1'-4"	1'-5"	1'-6"	H	
	I	1'-11"	2'-0 1/2"	2'-3"	2'-5 1/2"	2'-8"	2'-10 1/2"	3'-1"	3'-3 1/2"	3'-6"	3'-8 1/2"	I	
	J	5'-8 1/2"	6'-4 1/4"	7'-1 1/4"	7'-10"	8'-7"	9'-4"	10'-0 3/4"	10'-9 5/8"	11'-7"	12'-4 1/8"	J	
	K	4'-5 1/2"	4'-11 1/2"	5'-6 3/4"	6'-1 7/8"	6'-9"	7'-4 1/8"	7'-11 1/4"	8'-6 1/2"	9'-2"	9'-9 1/8"	K	
	L	6'-7 5/8"	7'-6"	8'-4 1/2"	9'-2 1/8"	10'-1 1/4"	10'-11 5/8"	11'-10"	12'-8 3/8"	13'-6 7/8"	14'-5 1/4"	L	
	M	1'-1 1/4"	1'-2 1/8"	1'-3 5/8"	1'-5"	1'-6 1/2"	1'-8"	1'-9 3/8"	1'-10 3/4"	2'-0 3/8"	2'-2"	M	
	N	0'-5 3/4"	0'-5 3/4"	0'-6 3/4"	0'-6 3/8"	0'-7 1/2"	0'-8 1/8"	0'-8 5/8"	0'-9 1/4"	0'-10"	0'-10 1/2"	N	
	O	0'-11 1/2"	0'-11 1/2"	1'-0 1/2"	1'-1 1/2"	1'-2 1/2"	1'-3 1/2"	1'-4 1/2"	1'-5 1/2"	1'-6 1/2"	1'-7 1/2"	O	
	P	5'-9"	6'-6"	7'-3"	8'-0"	8'-9"	9'-6"	10'-3"	11'-0"	11'-9"	12'-6"	P	
	R	1'-1"	1'-2 1/2"	1'-4"	1'-5 1/2"	1'-7"	1'-8 1/2"	1'-10"	1'-11 1/2"	2'-1"	2'-2 1/2"	R	
CUBIC YARDS CONCRETE	CONC. PIPE	3.558	4.373	5.635	7.089	8.776	10.702	12.861	15.303	18.195	21.285	CONC. PIPE	
	C.M. PIPE	3.791	4.680	6.054	7.642	9.490	11.605	13.984	16.678	19.724	23.107	C.M. PIPE	
FOR 2:1 FILL SLOPE	C	4'-4"	4'-10 7/8"	5'-5 3/4"	6'-0 3/4"	6'-7 5/8"	7'-2 5/8"	7'-9 1/2"	8'-4 1/2"	8'-11 3/8"	9'-6 1/4"	C	
	F	0'-6 1/2"	0'-7"	0'-7 1/2"	0'-8"	0'-8 1/2"	0'-9"	0'-9 1/2"	0'-10"	0'-10 1/2"	0'-11"	F	
	G	4'-3"	4'-9"	5'-3"	5'-9"	6'-3"	6'-9"	7'-3"	7'-9"	8'-3"	8'-9"	G	
	I	1'-10 3/4"	2'-0 1/4"	2'-2 3/4"	2'-5 1/4"	2'-7 3/4"	2'-10 1/4"	3'-0 3/4"	3'-3 1/4"	3'-5 3/4"	3'-8 1/4"	I	
	J	5'-8 1/4"	6'-4"	7'-1"	7'-9 3/4"	8'-6 3/4"	9'-3 1/2"	10'-0 1/2"	10'-9 1/8"	11'-6 3/8"	12'-3 1/2"	J	
	L	8'-8"	9'-9 3/4"	10'-11 5/8"	12'-1 1/2"	13'-3 3/8"	14'-5 1/4"	15'-7"	16'-9"	17'-10 3/4"	19'-0 5/8"	L	
	M	1'-1 1/8"	1'-2"	1'-3 1/2"	1'-4 7/8"	1'-6 3/8"	1'-7 3/4"	1'-9 1/4"	1'-10 5/8"	2'-0 1/4"	2'-1 1/8"	M	
	P	7'-6"	8'-6"	9'-6"	10'-6"	11'-6"	12'-6"	13'-6"	14'-6"	15'-6"	16'-6"	P	
R	1'-0 3/4"	1'-2 1/4"	1'-3 3/4"	1'-5 1/4"	1'-6 3/4"	1'-8 1/4"	1'-9 3/4"	1'-11 1/4"	2'-0 3/4"	2'-2 1/4"	R		
CUBIC YARDS CONCRETE	CONC. PIPE	4.238	5.230	6.761	8.538	10.602	12.958	15.612	18.623	22.104	25.898	CONC. PIPE	
	C.M. PIPE	4.469	5.536	7.177	9.088	11.312	13.856	16.730	19.993	23.618	27.704	C.M. PIPE	
FOR 1/2:1 AND 2:1 FILL SLOPES	a	0'-4 1/2"	0'-5"	0'-5 3/4"	0'-6 1/4"	0'-7"	0'-7 1/2"	0'-8 1/4"	0'-8 3/4"	0'-9 1/2"	0'-10"	a	
	b	0'-3 1/2"	0'-4"	0'-4 1/2"	0'-5"	0'-5 1/2"	0'-6"	0'-6 1/2"	0'-7"	0'-7 1/2"	0'-8"	b	

FOR ALL DIMENSIONS NOT SHOWN SEE VALUES LISTED ABOVE FOR 1/2:1 FILL SLOPE

TABLE OF DIMENSIONS AND CONCRETE VOLUMES PER ENDWALL
FOR ELLIPTICAL PIPE CULVERTS

SIZE OF ELLIPTICAL PIPE CULVERTS (SPAN X RISE)

FOR 1/2:1 FILL SLOPE	DIMENSION	60 x 38	68 x 43	76 x 48	83 x 53	91 x 58	98 x 63	106 x 68	DIMENSION	
	A	1'-6"	1'-6"	1'-6"	1'-6"	1'-6"	1'-6"	1'-6"	1'-6"	A
	B	4'-9 1/2"	4'-9 1/2"	5'-4"	5'-10 1/2"	6'-5"	6'-11 1/2"	7'-6"	B	
	C	3'-3 3/4"	3'-3 3/4"	3'-9"	4'-2 1/4"	4'-7 1/2"	5'-0 5/8"	5'-5 3/4"	C	
	D	3'-2"	3'-7"	4'-0"	4'-5"	4'-10"	5'-8"	5'-8"	D	
	E	0'-6"	0'-6"	0'-6"	0'-6"	0'-6"	0'-6"	0'-6"	E	
	F	0'-5 1/2"	0'-5 1/2"	0'-6"	0'-6 1/2"	0'-7"	0'-7 1/2"	0'-8"	F	
	G	4'-4"	4'-4"	4'-10"	5'-4"	5'-10"	6'-4"	6'-10"	G	
	H	0'-10"	0'-10"	0'-10"	0'-11"	1'-0"	1'-1"	1'-2"	H	
	I	1'-11"	1'-11"	2'-0 1/2"	2'-3"	2'-5 1/2"	2'-8"	2'-10 1/2"	I	
	J	7'-2 1/2"	7'-10 1/2"	8'-8 1/4"	9'-6 1/4"	10'-5"	11'-3"	12'-2"	J	
	K	5'-11 1/2"	6'-7 1/2"	7'-3 1/2"	7'-11 3/4"	8'-8 1/8"	9'-5"	10'-2 1/8"	K	
	L	6'-7 5/8"	6'-7 5/8"	7'-6"	8'-4 1/2"	9'-2 1/8"	10'-1 1/4"	10'-11 5/8"	L	
	M	1'-1 1/4"	1'-1 1/4"	1'-2 1/8"	1'-3 5/8"	1'-5"	1'-6 1/2"	1'-8"	M	
	N	0'-5 3/4"	0'-5 3/4"	0'-5 3/4"	0'-6 3/8"	0'-6 1/8"	0'-7 1/2"	0'-8 1/2"	N	
	O	0'-11 1/2"	0'-11 1/2"	0'-11 1/2"	1'-0 1/2"	1'-1 1/2"	1'-2 1/2"	1'-3 1/2"	O	
	P	5'-9"	5'-9"	6'-6"	7'-3"	8'-0"	8'-9"	9'-6"	P	
R	1'-1"	1'-1"	1'-2 1/2"	1'-4"	1'-5 1/2"	1'-7"	1'-8 1/2"	R		
S	5'-0"	5'-8"	6'-4"	6'-11"	7'-7"	8'-2"	8'-10"	S		
CUBIC YARDS CONCRETE	CONCRETE PIPE	3.793	3.747	4.601	5.913	7.433	9.191	11.207	CONCRETE PIPE	
FOR 2:1 FILL SLOPE	C	4'-4"	4'-4"	4'-10 7/8"	5'-5 3/4"	6'-0 3/4"	6'-7 5/8"	7'-2 5/8"	C	
	F	0'-6 1/2"	0'-6 1/2"	0'-7"	0'-7 1/2"	0'-8"	0'-8 1/2"	0'-9"	F	
	G	4'-3"	4'-3"	4'-9"	5'-3"	5'-9"	6'-3"	6'-9"	G	
	I	1'-10 3/4"	1'-10 3/4"	2'-0 1/4"	2'-2 3/4"	2'-5 1/4"	2'-7 3/4"	2'-10 1/4"	I	
	J	7'-2 1/2"	7'-10 1/2"	8'-8 1/4"	9'-6 1/4"	10'-5"	11'-3"	12'-2"	J	
	L	8'-8"	8'-8"	9'-9 3/4"	10'-11 5/8"	12'-1 1/2"	13'-3 3/8"	14'-5 1/4"	L	
	M	1'-1 1/8"	1'-1 1/8"	1'-2"	1'-3 1/2"	1'-4 7/8"	1'-6 3/8"	1'-7 3/4"	M	
	P	7'-6"	7'-6"	8'-6"	9'-6"	10'-6"	11'-6"	12'-6"	P	
R	1'-0 3/4"	1'-0 3/4"	1'-2 1/4"	1'-3 3/4"	1'-5 1/4"	1'-6 3/4"	1'-8 1/4"	R		
CUBIC YARDS CONCRETE	CONCRETE PIPE	4.469	4.423	5.453	7.034	8.876	11.010	13.457	CONCRETE PIPE	
FOR 1/2:1 AND 2:1 FILL SLOPES	a	0'-6 1/4"	0'-7"	0'-8"	0'-8 3/4"	0'-9 1/2"	0'-10 1/4"	0'-11"	a	
	b	0'-5"	0'-5 3/4"	0'-6 1/4"	0'-7"	0'-7 1/2"	0'-8"	0'-8 3/4"	b	

FOR ALL DIMENSIONS NOT SHOWN SEE VALUES LISTED ABOVE FOR 1/2:1 FILL SLOPES

SPECIFICATION
REFERENCE

105
302

STANDARD ENDWALL FOR PIPE CULVERTS
60" x 38" - 106" x 68" ELLIPTICAL PIPES
VIRGINIA DEPARTMENT OF TRANSPORTATION

VDOT
ROAD AND BRIDGE STANDARDS
REVISION DATE SHEET 3 OF 3
101.05

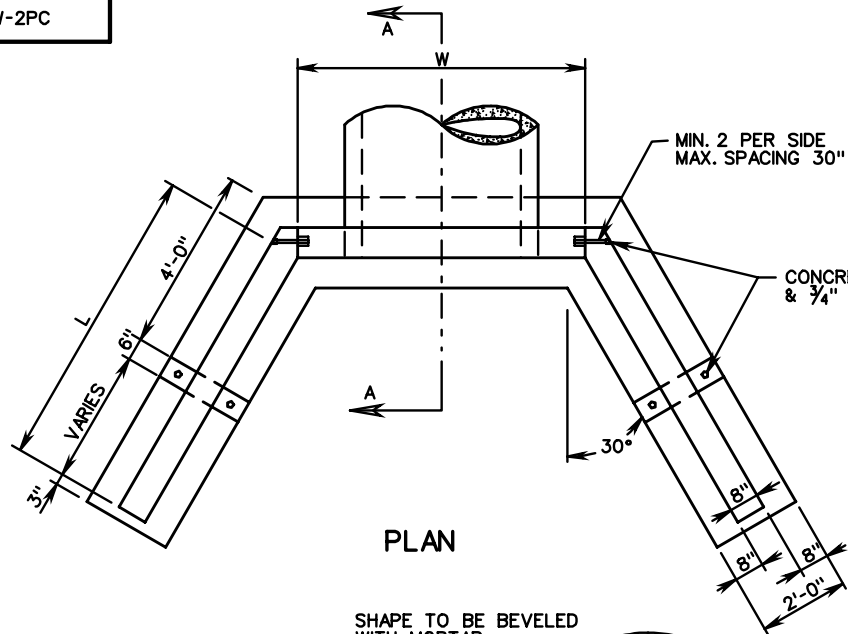

PLAN

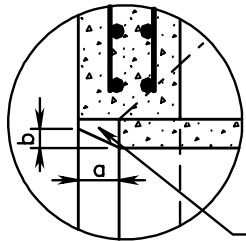

DETAIL A

SHAPE TO BE BEVELED WITH MORTAR

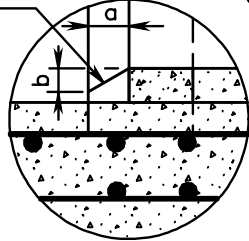

DETAIL B

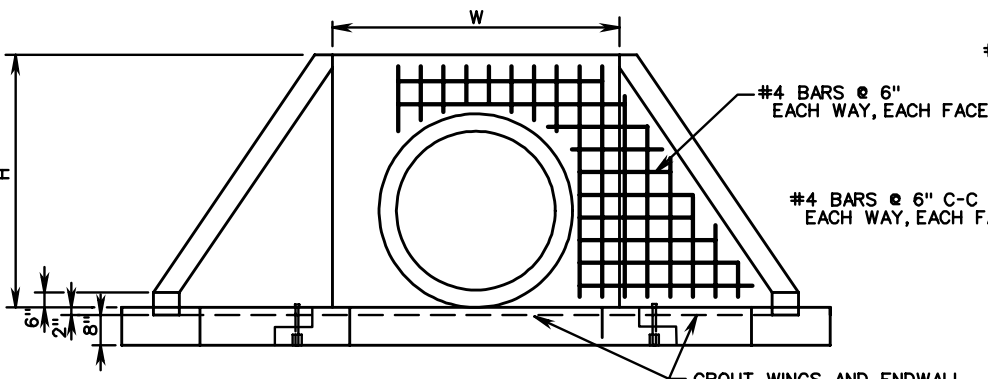

FRONT ELEVATION

- NOTES:**
1. CONCRETE TO BE 4000 PSI MINIMUM COMPRESSIVE STRENGTH.
 2. IF PIPE IS TO BE SKEWED, THE OPENING WILL BE ADJUSTED TO ACCOMMODATE ANGLES UP TO 15°.
 3. REINFORCING STEEL IN ACCORDANCE WITH ASTM A-615 (REINFORCING BARS).
 4. PIPE OPENINGS IN PRECAST DRAINAGE UNITS SHALL NOT EXCEED 4 INCHES AT ANY GIVEN POINT BETWEEN THE PIPE AND THE PRECAST UNIT.
 5. DIMENSIONS SHOWN ARE MINIMUM. ACTUAL MEASUREMENTS MAY VARY WITH MANUFACTURER'S TOLERANCES.
 6. IN NO CASE SHALL TOP OF ENDWALL PROTRUDE ABOVE FILL SLOPE, DITCH SLOPE, OR SHOULDER.
 7. HEADWALL TO BE BEVELED IN ALL AREAS EXCEPT WHERE A CONFLICT WITH INVERT OR WINGWALL OCCUR.
 8. BEVEL EDGE AS REQUIRED ON THE HEADWALL AT THE INLET END OF THE CULVERT (WHERE THE FLOW ENTERS THE CULVERT).
 9. HEADWALL AT THE OUTLET END OF THE CULVERT MAY BE EITHER SQUARE EDGE OR BEVEL EDGE.
 10. 3/4" CHAMFER MAY BE PROVIDED ON ALL EDGES AT MANUFACTURER'S OPTION.

DIMENSIONS

D	H	W	L		a	b
			1/2:1 SLOPE	2:1 SLOPE		
42"	5'-6"	6'-3"	6'-7 1/2"	8'-8"	0'-4 1/2"	0'-3 1/2"
48"	6'-0"	6'-10"	7'-6"	9'-10"	0'-5"	0'-4"
54"	6'-6"	7'-5"	8'-4 1/2"	11'-0"	0'-5 3/4"	0'-4 1/2"
60"	7'-0"	8'-0"	9'-3"	12'-1 1/2"	0'-6 1/4"	0'-5"
66"	7'-7"	8'-8 1/2"	10'-1 1/2"	13'-3 1/2"	0'-7"	0'-5 1/2"
72"	8'-2"	9'-3 1/2"	11'-0"	14'-5 1/2"	0'-7"	0'-5 1/2"
78"	8'-8 1/2"	9'-10"	11'-10"	15'-7"	0'-7"	0'-5 1/2"
84"	9'-3"	10'-4"	12'-8 1/2"	16'-9"	0'-7"	0'-5 1/2"
90"	9'-11"	11'-1"	13'-7"	17'-11"	0'-7"	0'-5 1/2"
96"	10'-7"	11'-8"	14'-6"	19'-1"	0'-7"	0'-5 1/2"

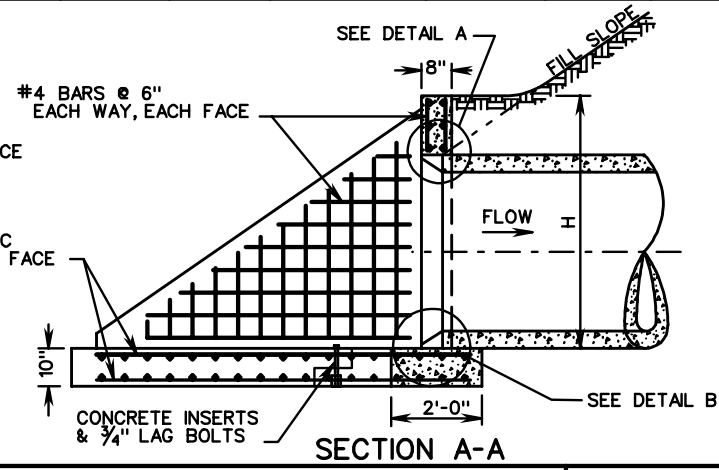

SECTION A-A



ROAD AND BRIDGE STANDARDS

PRECAST ENDWALL FOR PIPE CULVERTS

SPECIFICATION REFERENCE

SHEET 1 OF 1

REVISION DATE

42" - 96" CIRCULAR PIPE

105
302

101.06

VIRGINIA DEPARTMENT OF TRANSPORTATION

NOTES:

1. CONCRETE TO BE 4000 PSI MINIMUM COMPRESSIVE STRENGTH.
2. IF PIPE IS TO BE SKEWED, THE OPENING WILL BE ADJUSTED TO ACCOMMODATE ANGLES UP TO 15°.
3. REINFORCING STEEL IN ACCORDANCE WITH ASTM A-615 (REINFORCING BARS).
4. PIPE OPENINGS IN PRECAST DRAINAGE UNITS SHALL NOT EXCEED 4 INCHES AT ANY GIVEN POINT BETWEEN THE PIPE AND THE PRECAST UNIT.
5. DIMENSIONS SHOWN ARE MINIMUM. ACTUAL MEASUREMENTS MAY VARY WITH MANUFACTURER'S TOLERANCES.
6. IN NO CASE SHALL TOP OF ENDWALL PROTRUDE ABOVE FILL SLOPE OR SHOULDER.
7. HEADWALL TO BE BEVELED IN ALL AREAS EXCEPT WHERE A CONFLICT WITH INVERT OR WINGWALL OCCUR.
8. BEVEL EDGE AS REQUIRED ON THE HEADWALL AT THE INLET END OF THE CULVERT (WHERE THE FLOW ENTERS THE CULVERT).
9. HEADWALL AT THE OUTLET END OF THE CULVERT MAY BE EITHER SQUARE EDGE OR BEVEL EDGE.
10. 3/4" CHAMFER MAY BE PROVIDED ON ALL EDGES AT MANUFACTURER'S OPTION.

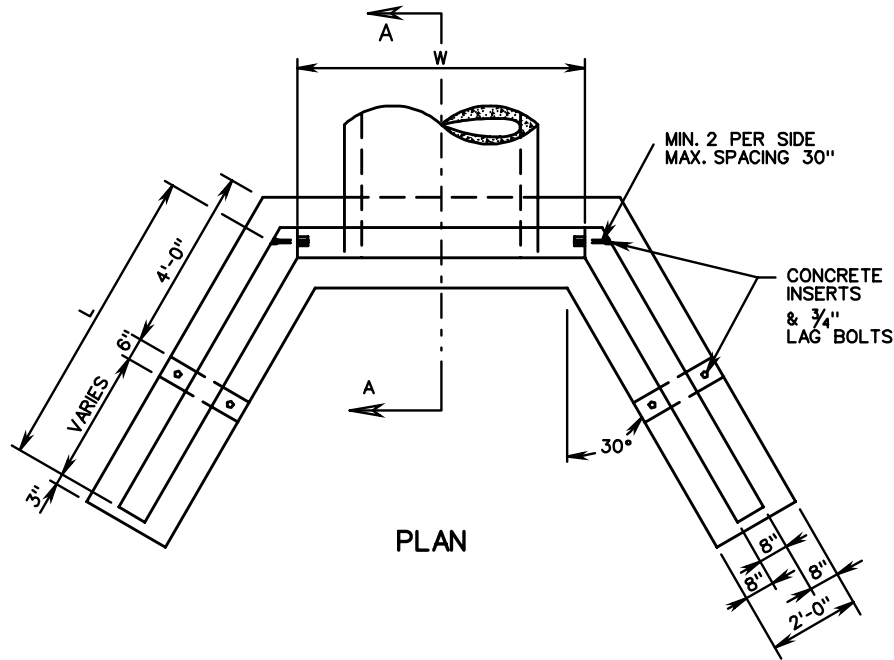

PLAN

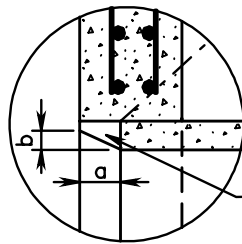

DETAIL A

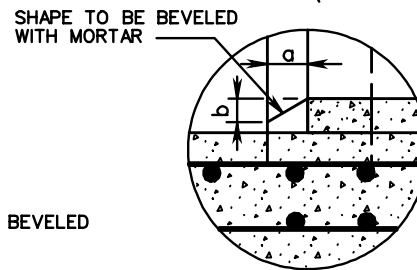

DETAIL B

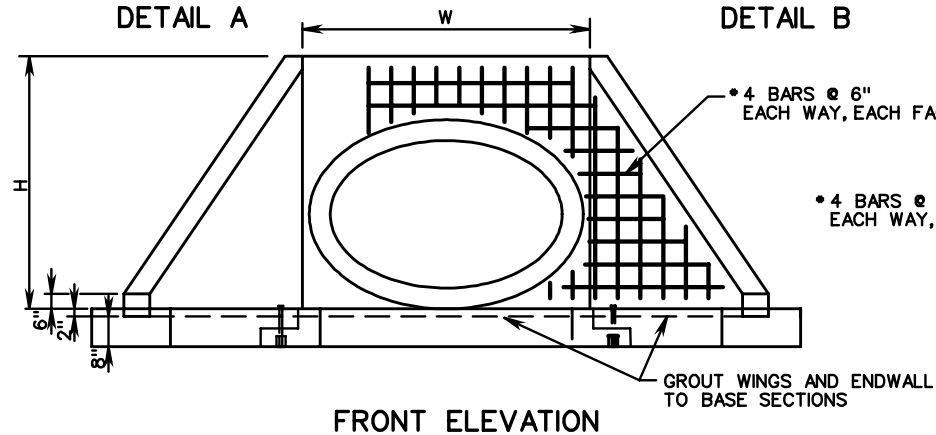

FRONT ELEVATION

PIPE ID	H	W	L		a	b
			1/2:1 SLOPE	2:1 SLOPE		
60"x38"	5'-6"	7'-11"	6'-7 1/2"	8'-8"	0'-6 1/4"	0'-5"
68"x43"	5'-6"	8'-8"	6'-7 1/2"	8'-8"	0'-7"	0'-5 3/4"
76"x48"	6'-0"	9'-5"	7'-6"	9'-10"	0'-7"	0'-5 3/4"
83"x53"	6'-6"	10'-1"	8'-4 1/2"	11'-0"	0'-7"	0'-5 3/4"
91"x58"	7'-0"	10'-10"	9-3"	12'-1 1/2"	0'-7"	0'-5 3/4"
98"x63"	7'-7"	11'-6"	10'-1 1/2"	13'-3 1/2"	0'-7"	0'-5 3/4"
106"x68"	8'-2"	12'-3"	11'-0"	14'-5 1/2"	0'-7"	0'-5 3/4"

DIMENSIONS

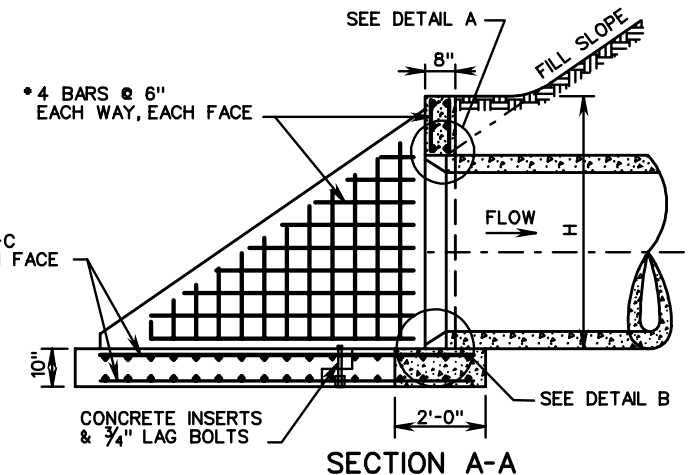

SECTION A-A

SPECIFICATION REFERENCE

105
302

STANDARD ENDWALL FOR PIPE CULVERTS

60" x 38" - 106" x 68" ELLIPTICAL PIPES

VIRGINIA DEPARTMENT OF TRANSPORTATION



ROAD AND BRIDGE STANDARDS

REVISION DATE

SHEET 1 OF 1

101.07

NOTES:

1. ALL DETAILS AND DIMENSIONS NOT SHOWN ARE THE SAME AS STANDARD EW-2. FOR TABLES OF DIMENSIONS AND VOLUMES SEE SHEET 2 OF 2. FOR DETAILS OF BEVEL REFER TO STANDARD EW-1, 1APC SHEET 101.02.
2. THIS ITEM MAY BE PRECAST OR CAST IN PLACE.
3. ALL CAST IN PLACE CONCRETE TO BE CLASS A3. FOR PRECAST SEE SHEET 101.10.
4. COST OF BARS FOR CRACK CONTROL TO BE INCLUDED IN PRICE BID PER CUBIC YARD CONCRETE.
5. HEADWALL TO BE BEVELED IN ALL AREAS EXCEPT WHERE A CONFLICT WITH INVERT OR WINGWALLS OCCUR.
6. BEVEL EDGE IS REQUIRED ON THE HEADWALL AT THE INLET END OF THE CULVERT (WHERE THE FLOW ENTERS THE CULVERT).
7. HEADWALL AT THE OUTLET END OF THE CULVERT MAY BE EITHER SQUARE EDGE OR BEVEL EDGE.
8. ON SHALLOW FILLS, WHERE ENDWALLS ARE 1' OR LESS BELOW SHOULDER LINE, THE TOP OF THE ENDWALL SHALL BE CONSTRUCTED PARALLEL TO THE GRADE OF THE ROAD.
9. IN NO CASE SHALL TOP OF ENDWALL PROJECT ABOVE FILL SLOPE, DITCH SLOPE, OR SHOULDER.
10. 3/4" CHAMFER MAY BE PROVIDED ON ALL EDGES AT MANUFACTURER'S OPTION.

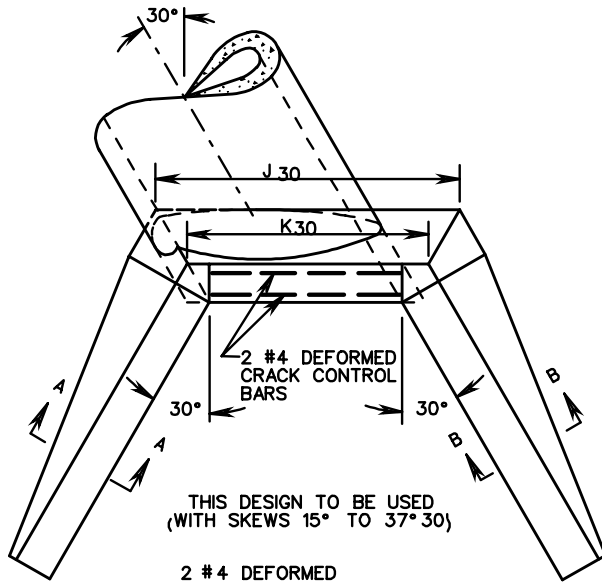

THIS DESIGN TO BE USED
(WITH SKEWS 15° TO 37° 30')

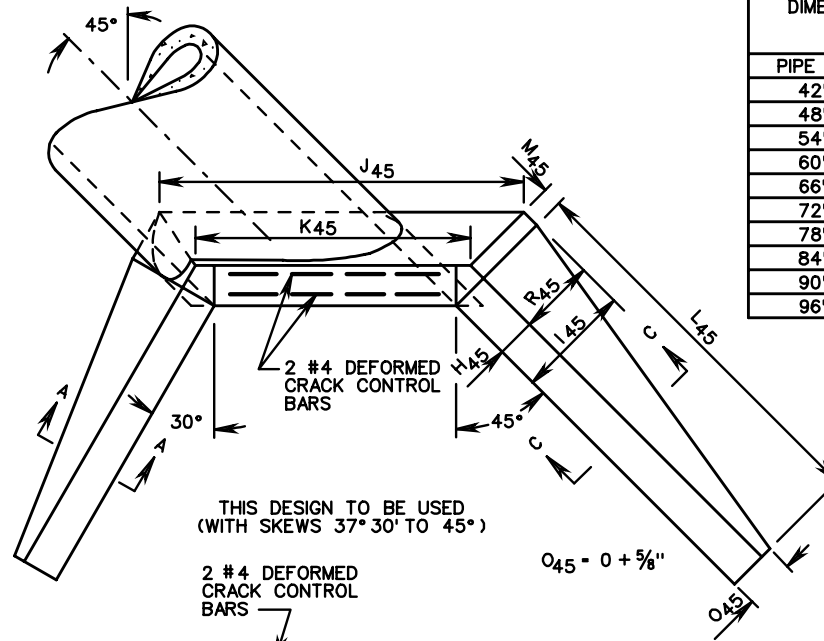

THIS DESIGN TO BE USED
(WITH SKEWS 37° 30' TO 45°)

DIMENSIONS FOR BEVEL ON HEADWALL		
PIPE I.D.	a	b
42"	0'-4 1/2"	0'-3 1/2"
48"	0'-5"	0'-4"
54"	0'-5 3/4"	0'-4 1/2"
60"	0'-6 1/4"	0'-5"
66"	0'-7"	0'-5 1/2"
72"	0'-7 1/2"	0'-6"
78"	0'-8 1/4"	0'-6 1/2"
84"	0'-8 3/4"	0'-7"
90"	0'-9 1/2"	0'-7 1/2"
96"	0'-10"	0'-8"

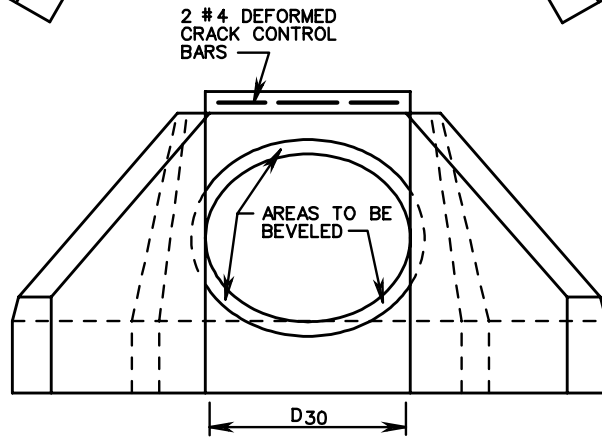

30° SKEW

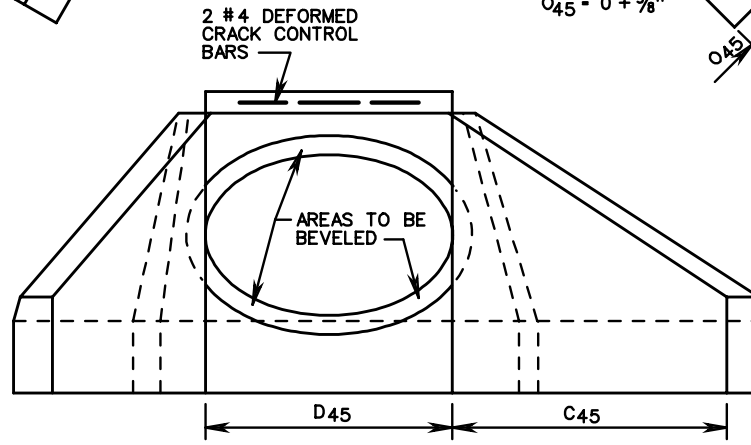

45° SKEW

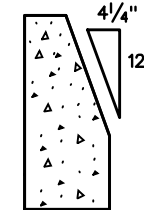

SECTION C-C

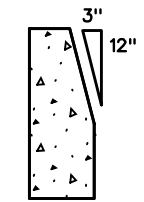

SECTION B-B

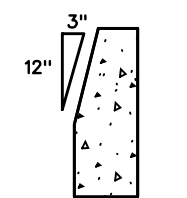

SECTION A-A



ROAD AND BRIDGE STANDARDS

STANDARD ENDWALLS FOR PIPE CULVERTS

42" - 96" CIRCULAR PIPES WITH 30° AND 45° SKEW

VIRGINIA DEPARTMENT OF TRANSPORTATION

SPECIFICATION REFERENCE

105
302

SHEET 1 OF 2

REVISION DATE

101.08

TABLE OF DIMENSIONS AND CONCRETE VOLUMES PER ENDWALL

FOR 1/2:1 FILL SLOPE

DIAMETER OF PIPE CULVERTS

30° SKEW	DIMENSION	42"	48"	54"	60"	66"	72"	78"	84"	90"	96"	DIMENSION
	D 30	4'-0 1/2"	4'-7 3/8"	5'-2 3/8"	5'-9 3/8"	6'-4 1/4"	6'-11 1/8"	7'-6 1/8"	8'-1"	8'-8"	9'-2 7/8"	D 30
	J 30	6'-3"	6'-11 5/8"	7'-9 5/8"	8'-7 3/8"	9'-5 1/4"	10'-3 1/8"	11'-0 1/8"	11'-10 1/2"	12'-8 1/2"	13'-6 1/4"	J 30
	K 30	5'-0"	5'-6 7/8"	6'-3 1/8"	6'-11 1/8"	7'-7 1/4"	8'-3 3/8"	8'-11 3/8"	9'-7 1/2"	10'-3 1/2"	10'-11 3/4"	K 30
CUBIC YARDS CONCRETE	CONC. PIPE	3.631	4.459	5.745	7.223	8.934	10.885	13.076	15.544	18.456	21.582	CONC. PIPE
	C.M. PIPE	3.900	4.814	6.228	7.861	9.758	11.928	14.373	17.132	20.221	23.686	C.M. PIPE
45° SKEW	C 45	5'-9"	6'-6"	7'-3"	8'-0"	8'-9"	9'-6"	10'-3"	11'-0"	11'-9"	12'-6"	C 45
	D 45	4'-11 3/8"	5'-7 7/8"	6'-4 3/8"	7'-0 7/8"	7'-9 3/8"	8'-5 7/8"	9'-2 1/4"	9'-10 3/4"	10'-7 1/4"	11'-3 3/4"	D 45
	I 45	2'-4 3/8"	2'-6 1/4"	2'-9 5/8"	3'-0 3/4"	3'-3 7/8"	3'-7"	3'-10 1/8"	4'-1 1/4"	4'-4 3/4"	4'-8 1/4"	I 45
	J 45	7'-5 3/4"	8'-4 5/8"	9'-4 1/2"	10'-4 3/8"	11'-4 1/4"	12'-4 1/8"	13'-3 3/8"	14'-3 1/8"	15'-4 1/8"	16'-4 1/2"	J 45
	K 45	5'-9 1/4"	6'-5 3/4"	7'-3 1/4"	8'-0 3/4"	8'-10 1/4"	9'-7 3/4"	10'-5 1/8"	11'-2 5/8"	12'-0 1/8"	12'-9 5/8"	K 45
	L 45	8'-1 9/8"	9'-2 1/4"	10'-3"	11'-3 3/4"	12'-4 1/2"	13'-5 1/4"	14'-6"	15'-6 5/8"	16'-7 1/2"	17'-8 1/8"	L 45
	M 45	0'-4 1/8"	0'-4 1/8"	0'-4 1/2"	0'-5"	0'-5 3/8"	0'-5 3/4"	0'-6 1/4"	0'-6 5/8"	0'-7"	0'-7 1/2"	M 45
	R 45	1'-6 3/8"	1'-8 1/2"	1'-10 5/8"	2'-0 3/4"	2'-2 7/8"	2'-5"	2'-7 1/8"	2'-9 1/4"	2'-11 3/4"	3'-2 1/4"	R 45
CUBIC YARDS CONCRETE	CONC. PIPE	4.231	5.191	6.712	8.447	10.441	12.714	15.276	18.150	21.420	25.107	CONC. PIPE
	C.M. PIPE	4.542	5.604	7.274	9.189	11.400	13.927	16.783	19.997	23.582	27.684	C.M. PIPE

FOR 2:1 FILL SLOPE

DIAMETER OF PIPE CULVERTS

30° SKEW		42"	48"	54"	60"	66"	72"	78"	84"	90"	96"	
	D 30	4'-0 1/2"	4'-7 3/8"	5'-2 3/8"	5'-9 3/8"	6'-4 1/4"	6'-11 1/8"	7'-6 1/8"	8'-1"	8'-8"	9'-2 7/8"	D 30
	J 30	6'-2 3/4"	6'-11 3/8"	7'-9 3/8"	8'-7 1/8"	9'-5"	10'-2 5/8"	11'-0 5/8"	11'-10 1/4"	12'-8 1/8"	13'-6"	J 30
	K 30	5'-0"	5'-6 7/8"	6'-3 1/8"	6'-11 1/8"	7'-7 1/4"	8'-3 3/8"	8'-11 3/8"	9'-7 1/2"	10'-3 1/2"	10'-11 3/4"	K 30
CUBIC YARDS CONCRETE	CONC. PIPE	4.310	5.315	6.868	8.669	10.757	13.138	15.823	18.863	22.368	26.201	CONC. PIPE
	C.M. PIPE	4.576	5.668	7.349	9.304	11.577	14.175	17.114	20.444	24.117	28.287	C.M. PIPE
45° SKEW	C 45	7'-6"	8'-6"	9'-6"	10'-6"	11'-6"	12'-6"	13'-6"	14'-6"	15'-6"	16'-6"	C 45
	D 45	4'-11 3/8"	5'-7 7/8"	6'-4 3/8"	7'-0 7/8"	7'-9 3/8"	8'-5 7/8"	9'-2 1/4"	9'-10 3/4"	10'-7 1/4"	11'-3 3/4"	D 45
	I 45	2'-4"	2'-6 1/8"	2'-9 1/4"	3'-0 3/8"	3'-3 1/2"	3'-6 5/8"	3'-9 3/4"	4'-0 1/8"	4'-4 3/8"	4'-7 7/8"	I 45
	J 45	7'-5 3/8"	8'-4 1/4"	9'-4 1/8"	10'-4"	11'-3 3/8"	12'-3 5/8"	13'-3 1/2"	14'-3 1/4"	15'-3 3/4"	16'-4"	J 45
	K 45	5'-9 1/4"	6'-5 3/4"	7'-3 1/4"	8'-0 3/4"	8'-10 1/4"	9'-7 3/4"	10'-5 1/8"	11'-2 5/8"	12'-0 1/8"	12'-9 5/8"	K 45
	L 45	10'-7 1/4"	12'-0 1/4"	13'-5 1/4"	14'-10 1/4"	16'-3 1/8"	17'-8 1/8"	19'-1 1/8"	20'-6 1/8"	21'-11"	23'-4"	L 45
	M 45	0'-4 1/8"	0'-4 1/8"	0'-4 1/2"	0'-5"	0'-5 3/8"	0'-5 3/4"	0'-6 1/4"	0'-6 5/8"	0'-6 5/8"	0'-6 3/4"	M 45
	R 45	1'-6"	1'-8 1/8"	1'-10 1/4"	2'-0 3/8"	2'-2 1/2"	2'-4 5/8"	2'-6 3/4"	2'-8 7/8"	2'-11 3/8"	3'-1 1/8"	R 45
CUBIC YARDS CONCRETE	CONC. PIPE	5.043	6.254	8.071	10.295	12.637	15.429	18.585	22.142	26.158	30.689	CONC. PIPE
	C.M. PIPE	5.351	6.664	8.629	11.033	13.590	16.635	20.086	23.981	28.298	33.241	C.M. PIPE

SPECIFICATION
REFERENCE

105
302

STANDARD ENDWALLS FOR PIPE CULVERTS

42" - 96" CIRCULAR PIPES WITH 30° AND 45° SKEW

VIRGINIA DEPARTMENT OF TRANSPORTATION



ROAD AND BRIDGE STANDARDS

REVISION DATE

SHEET 2 OF 2

101.09

EW-2SPC

DIMENSIONS

ID	H	W	1/2:1 SLOPE		2:1 SLOPE		a	b
			L 30°	L 45°	L 30°	L 45°		
42"	5'-6"	8'-0"	6'-7 1/2"	8'-0"	8'-8"	10'-6"	0'-4 1/2"	0'-3 1/2"
48"	6'-0"	8'-10"	7'-6"	9'-2 1/2"	9'-9 3/4"	12'-0"	0'-5"	0'-4"
54"	6'-6"	9'-8"	8'-4 1/2"	10'-3"	10'-11 1/2"	13'-6"	0'-5 3/4"	0'-4 1/2"
60"	7'-0"	10'-6"	9'-3"	11'-3 1/2"	12'-1 1/4"	14'-10 1/4"	0'-6 1/4"	0'-5"
66"	7'-7"	11'-6"	10'-1 1/4"	12'-4 1/2"	13'-3 1/2"	16'-4"	0'-7"	0'-5 1/2"
72"	8'-2"	12'-4"	11'-0"	13'-5 1/2"	14'-5 1/2"	17'-8"	0'-7"	0'-6"
78"	8'-8 1/2"	13'-0"	11'-10"	14'-6"	15'-7"	19'-0"	0'-7"	0'-6 1/2"
84"	9'-3"	13'-10"	12'-8 1/2"	15'-6"	16'-9"	20'-6"	0'-7"	0'-7"
90"	9'-11"	14'-10"	13'-7"	16'-7 1/2"	17'-11"	21'-11"	0'-7"	0'-7 1/2"
96"	10'-7"	15'-10"	14'-5 1/4"	17'-8 1/4"	19'-1"	23'-4"	0'-7"	0'-8"

NOTES:

1. CONCRETE TO BE 4000 PSI MINIMUM COMPRESSIVE STRENGTH.
2. REINFORCING STEEL IN ACCORDANCE WITH ASTM A-615 (REINFORCING BARS).
3. PIPE OPENINGS IN PRECAST DRAINAGE UNITS SHALL NOT EXCEED 4 INCHES AT ANY GIVEN POINT BETWEEN THE PIPE AND THE PRECAST UNIT.
4. DIMENSIONS SHOWN ARE MINIMUM. ACTUAL MEASUREMENTS MAY VARY WITH MANUFACTURER'S TOLERANCES.
5. IN NO CASE SHALL TOP OF ENDWALL PROTRUDE ABOVE FILL SLOPE, DITCH SLOPE, OR SHOULDER.
6. HEADWALL TO BE BEVELED IN ALL AREAS EXCEPT WHERE A CONFLICT WITH INVERT OR WINGWALL OCCUR.
7. BEVEL EDGE AS REQUIRED ON THE HEADWALL AT THE INLET END OF THE CULVERT (WHERE THE FLOW ENTERS THE CULVERT).
8. HEADWALL AT THE OUTLET END OF THE CULVERT MAY BE EITHER SQUARE EDGE OR BEVEL EDGE.
9. 3/4" CHAMFER MAY BE PROVIDED ON ALL EDGES AT MANUFACTURER'S OPTION.

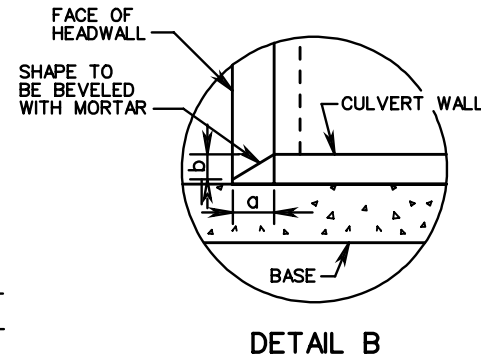
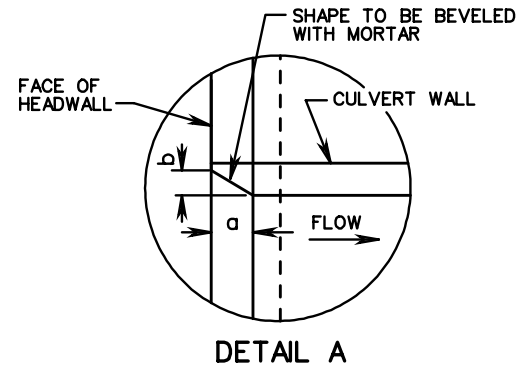
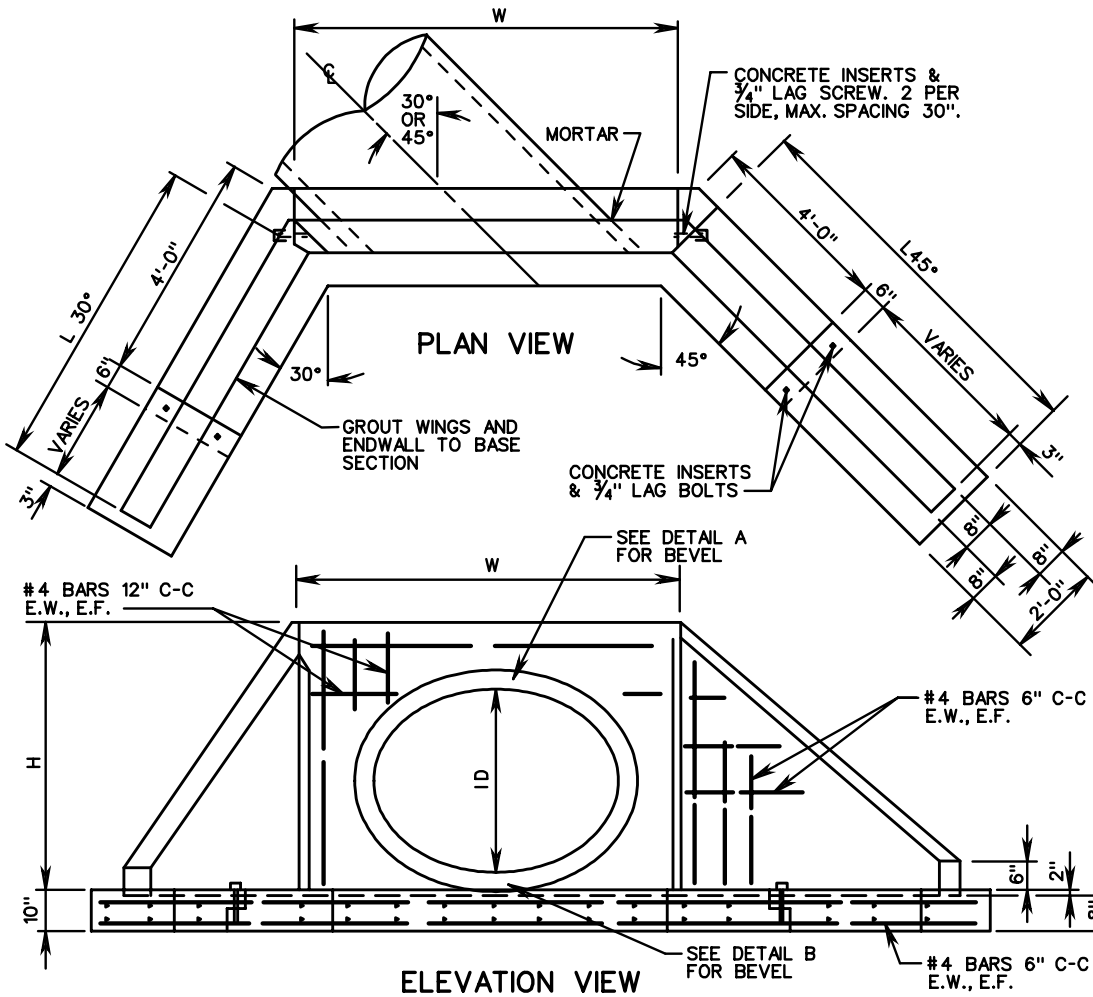

ROAD AND BRIDGE STANDARDS

SHEET 1 OF 1

REVISION DATE

101.10

PRECAST ENDWALL FOR PIPE CULVERTS

42" - 96" CIRCULAR PIPES WITH 30° AND 45° SKEW

VIRGINIA DEPARTMENT OF TRANSPORTATION

SPECIFICATION REFERENCE

105
302

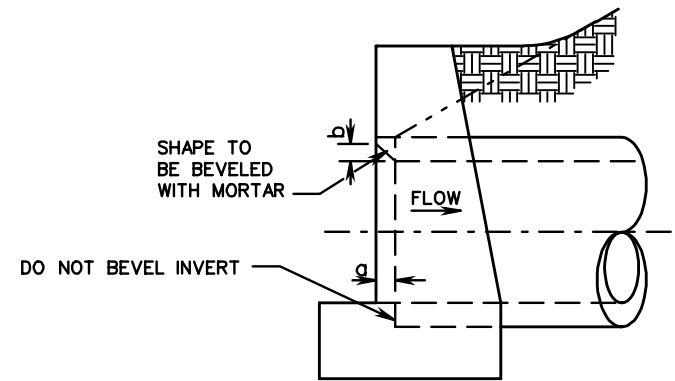
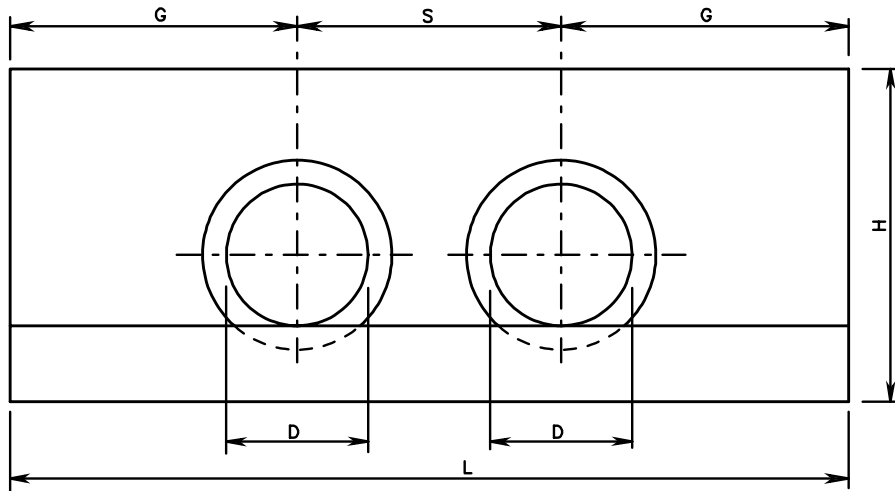

NOTES:

1. IN NO CASE SHALL TOP OF ENDWALL PROJECT ABOVE FILL SLOPE, DITCH SLOPE, DITCH SLOPE, OR SHOULDER.
2. THIS ITEM MAY BE PRECAST OR CAST IN PLACE.
3. ALL CAST IN PLACE CONCRETE TO BE CLASS A3. FOR PRECAST SEE SHEET 101.12.
4. THIS STANDARD TO BE USED WITH STRAIGHT CROSSINGS AND SKEW ANGLES TO 15°.
5. HEADWALL TO BE BEVELED IN ALL AREAS EXCEPT WHERE A CONFLICT WITH INVERT OR WINGWALLS OCCUR.
6. BEVEL EDGE IS REQUIRED ON THE HEADWALL AT THE INLET END OF THE CULVERT (WHERE THE FLOW ENTERS THE CULVERT).
7. HEADWALL AT THE OUTLET END OF THE CULVERT MAY BE EITHER SQUARE EDGE OR BEVEL EDGE.
8. ON SHALLOW FILLS, WHERE ENDWALLS ARE 1' OR LESS BELOW SHOULDER LINE, THE TOP OF THE ENDWALL SHALL BE CONSTRUCTED PARALLEL TO THE GRADE OF THE ROAD.
9. 3/4" CHAMFER MAY BE PROVIDED ON ALL EDGES AT MANUFACTURER'S OPTION.
10. QUANTITIES GIVEN ARE FOR ONE ENDWALL. PLEASE REFER TO STANDARD EW-1, SHEET 101.01 FOR ALL DIMENSIONS NOT GIVEN IN TABLES.

FOR CONCRETE PIPE							
D	S	G	L	CUBIC YARDS CONCRETE ONE DOUBLE ENDWALL	INCREASE FOR EACH ADDITIONAL PIPE	a	b
12"	1'-10"	2'-0"	5'-10"	0.329	0.088	0'-1 1/4"	0'-1"
15"	2'-3"	2'-6"	7'-3"	0.671	0.179	0'-1 3/4"	0'-1 1/4"
18"	2'-8"	3'-0"	8'-8"	0.941	0.244	0'-2"	0'-1 1/2"
21" OR 24"	3'-6"	4'-0"	11'-6"	1.763	0.444	0'-2 1/2"	0'-2"
27" OR 30"	4'-4"	5'-0"	14'-4"	2.730	0.663	0'-3 1/4"	0'-2 1/2"
33" OR 36"	5'-2"	6'-0"	17'-2"	3.854	0.907	0'-3 3/4"	0'-3"

FOR CORRUGATED METAL PIPE							
D	S	G	L	CUBIC YARDS CONCRETE ONE DOUBLE ENDWALL	INCREASE FOR EACH ADDITIONAL PIPE	a	b
12"	1'-7"	2'-0"	5'-7"	0.344	0.087	0'-1 1/4"	0'-1"
15"	1'- 11/2"	2'-6"	6'-11/2"	0.696	0.175	0'-1 3/4"	0'-1 1/4"
18"	2'-4"	3'-0"	8'-4"	0.980	0.241	0'-2"	0'-1 1/2"
24"	3'-1"	4'-0"	11'-1"	1.840	0.442	0'-2 1/2"	0'-2"
27" OR 30"	3'-10"	5'-0"	13'-10"	2.868	0.670	0'-3 1/4"	0'-2 1/2"
36"	4'-7"	6'-0"	16'-7"	4.076	0.931	0'-3 3/4"	0'-3"

SPECIFICATION REFERENCE
105 302

STANDARD ENDWALL FOR MULTIPLE PIPE CULVERTS
 12" - 36" CIRCULAR PIPES
 VIRGINIA DEPARTMENT OF TRANSPORTATION

VDOT ROAD AND BRIDGE STANDARDS	
REVISION DATE	SHEET 1 OF 1
	101.11

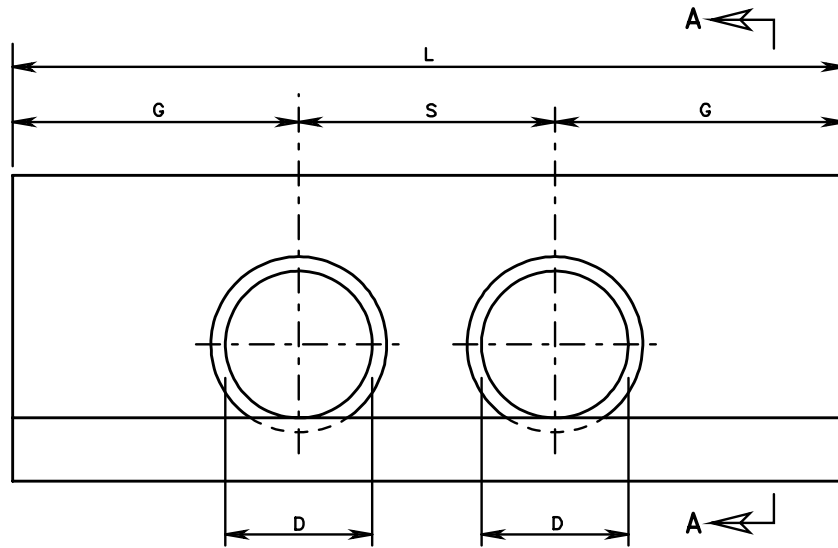

FRONT ELEVATION

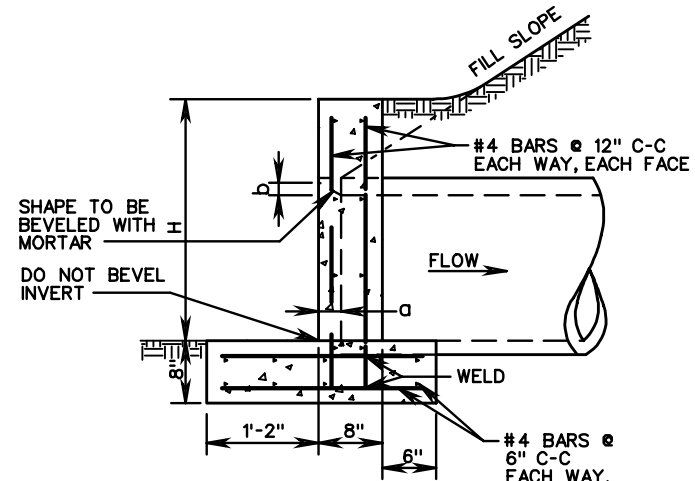

SECTION A-A

NOTES:

1. CONCRETE TO BE 4000 PSI MINIMUM COMPRESSIVE STRENGTH.
2. IF PIPE IS TO BE SKEWED THE OPENING WILL BE ADJUSTED TO ACCOMMODATE ANGLES UP TO 15°.
3. REINFORCING STEEL IN ACCORDANCE WITH ASTM A-615 (REINFORCING BARS).
4. PIPE OPENINGS IN PRECAST DRAINAGE UNITS SHALL NOT EXCEED 4 INCHES AT ANY GIVEN POINT BETWEEN THE PIPE AND THE PRECAST UNIT.
5. DIMENSIONS SHOWN ARE MINIMUM. ACTUAL MEASUREMENTS MAY VARY WITH MANUFACTURER'S TOLERANCE.
6. IN NO CASE SHALL TOP OF ENDWALL PROJECT ABOVE FILL SLOPE, DITCH SLOPE, OR SHOULDER.
7. HEADWALL TO BE BEVELED IN ALL AREAS EXCEPT WHERE A CONFLICT WITH INVERT OR WINGWALL OCCUR.
8. BEVEL EDGE IS REQUIRED ON THE HEADWALL AT THE INLET END OF THE CULVERT (WHERE THE FLOW ENTERS THE CULVERT). HEADWALL AT OUTLET END MAY BE EITHER SQUARE EDGE OR BEVELED.
9. 3/4" CHAMFER MAY BE PROVIDED ON ALL EDGES AT MANUFACTURER'S OPTION.

FOR CIRCULAR CONCRETE OR CORRUGATED METAL PIPE

FOR MULTIPLE PIPE ENDWALL

D	H	L	S	G	a	b
12"	2'-0"	5'-10"	2'-0"	1'-11"	0'-1 1/4"	0'-1"
15"	2'-3"	7'-3"	2'-3"	2'-6"	0'-1 3/4"	0'-1 1/4"
18"	2'-6"	8'-8"	2'-8"	3'-0"	0'-2"	0'-1 1/2"
21" OR 24"	3'-2"	11'-6"	3'-6"	4'-0"	0'-2 1/2"	0'-2"
27" OR 30"	3'-10"	14'-4"	4'-4"	5'-0"	0'-3 1/4"	0'-2 1/2"
33" OR 36"	4'-4"	17'-2"	5'-2"	6'-0"	0'-3 3/4"	0'-3"



ROAD AND BRIDGE STANDARDS

PRECAST ENDWALL FOR MULTIPLE PIPE CULVERTS

12" - 36" CIRCULAR PIPES

VIRGINIA DEPARTMENT OF TRANSPORTATION

SPECIFICATION REFERENCE

105
302

SHEET 1 OF 1

REVISION DATE

101.12

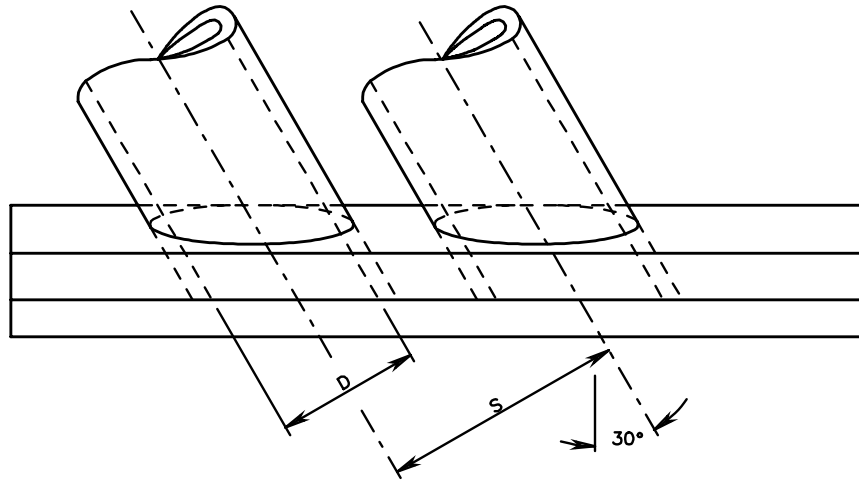

PLAN VIEW

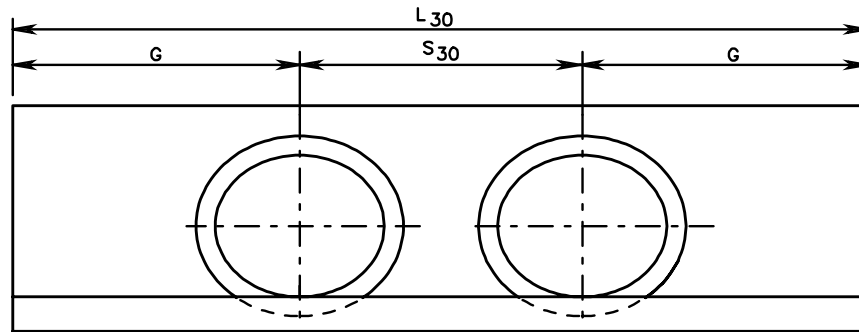

FRONT VIEW

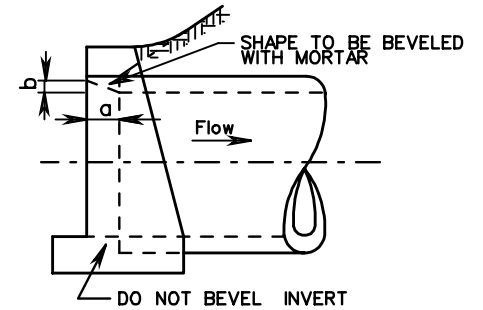

SIDE VIEW

NOTES:

1. QUANTITIES GIVEN ARE FOR ONE ENDWALL. PLEASE REFER TO STANDARD EW-1, SHEET 101.01 FOR ALL DIMENSIONS NOT GIVEN IN TABLES.
2. FOR DETAILS OF BEVEL SEE STANDARD EW-2, 2A, SHEET 101.03.
3. THIS ITEM MAY BE PRECAST OR CAST IN PLACE.
4. ON SHALLOW FILLS, WHERE ENDWALLS ARE 1' OR LESS BELOW SHOULDER LINE, THE TOP OF THE ENDWALL SHALL BE CONSTRUCTED PARALLEL TO THE GRADE OF ROAD.
5. ALL CAST IN PLACE CONCRETE TO BE CLASS A3. FOR PRECAST SEE SHEET 101.15.
6. IN NO CASE SHALL TOP OF ENDWALL PROJECT ABOVE FILL SLOPE, DITCH SLOPE, OR SHOULDER.
7. THIS STANDARD TO BE USED WITH SKEW ANGLES FROM 15° TO 37° 30'.
8. HEADWALL TO BE BEVELED IN ALL AREAS EXCEPT WHERE A CONFLICT WITH INVERT AND WINGWALLS OCCUR.
9. BEVEL EDGE IS REQUIRED ON THE HEADWALL AT THE INLET END OF THE CULVERT (WHERE THE FLOW ENTERS THE CULVERT). HEADWALL AT THE OUTLET END OF THE CULVERT MAY BE EITHER SQUARE EDGE OR BEVEL EDGE.
10. 3/4" CHAMFER MAY BE PROVIDED ON ALL EDGES AT MANUFACTURER'S OPTION.

FOR CONCRETE PIPE									
D	G	S	S ₃₀	L ₃₀	CONCRETE IN ONE DOUBLE ENDWALL CUBIC YDS.	INCREASE FOR EACH ADDITIONAL PIPE CUBIC YDS.	a	b	
12"	2'-0"	1'-10"	2'-1 ³ / ₈ "	6'-1 ³ / ₈ "	0.336	0.101	0'-1 ¹ / ₄ "	0'-1"	
15"	2'-6"	2'-3"	2'-7 ⁷ / ₈ "	7'-7 ⁷ / ₈ "	0.688	0.207	0'-1 ³ / ₄ "	0'-1 ¹ / ₄ "	
18"	3'-0"	2'-8"	3'-1"	9'-1"	0.962	0.283	0'-2"	0'-1 ¹ / ₂ "	
21" OR 24"	4'-0"	3'-6"	4'-0 ¹ / ₂ "	12'-0 ¹ / ₂ "	1.794	0.512	0'-2 ¹ / ₂ "	0'-2"	
27" OR 30"	5'-0"	4'-4"	5'-0"	15'-0"	2.769	0.765	0'-3 ¹ / ₄ "	0'-2 ¹ / ₂ "	
33" OR 36"	6'-0"	5'-2"	5'-11 ⁵ / ₈ "	17'-11 ⁵ / ₈ "	3.895	1.048	0'-3 ³ / ₄ "	0'-3"	

FOR CORRUGATED METAL PIPE									
D	G	S	S ₃₀	L ₃₀	CONCRETE IN ONE DOUBLE ENDWALL CUBIC YDS.	INCREASE FOR EACH ADDITIONAL PIPE CUBIC YDS.	a	b	
12"	2'-0"	1'-7"	1'-10"	5'-10"	0.354	0.100	0'-1 ¹ / ₄ "	0'-1"	
15"	2'-6"	1'-11 ¹ / ₂ "	2'-3 ³ / ₈ "	7'-3 ³ / ₈ "	0.714	0.201	0'-1 ³ / ₄ "	0'-1 ¹ / ₄ "	
18"	3'-0"	2'-4"	2'-8 ³ / ₈ "	8'-8 ³ / ₈ "	1.005	0.278	0'-2"	0'-1 ¹ / ₂ "	
24"	4'-0"	3'-1"	3'-6 ³ / ₄ "	11'-6 ³ / ₄ "	1.882	0.510	0'-2 ¹ / ₂ "	0'-2"	
27" OR 30"	5'-0"	3'-10"	4'-5 ⁵ / ₈ "	14'-5 ⁵ / ₈ "	2.929	0.775	0'-3 ¹ / ₄ "	0'-2 ¹ / ₂ "	
36"	6'-0"	4'-7"	5'-3 ¹ / ₂ "	17'-3 ¹ / ₂ "	4.153	1.075	0'-3 ³ / ₄ "	0'-3"	

SPECIFICATION REFERENCE

105
302

STANDARD ENDWALLS FOR MULTIPLE PIPE CULVERTS
12" - 36" CIRCULAR PIPES WITH 30° SKEW

VIRGINIA DEPARTMENT OF TRANSPORTATION

VDOT

ROAD AND BRIDGE STANDARDS

REVISION DATE

SHEET 1 OF 2

101.13

NOTES:

1. QUANTITIES GIVEN ARE FOR ONE ENDWALL. PLEASE REFER TO STANDARD EW-1, SHEET 101.01 FOR ALL DIMENSIONS NOT GIVEN IN TABLES.
2. FOR DETAILS OF BEVEL SEE STANDARD EW-2, 2A, SHEET 101.03.
3. THIS ITEM MAY BE PRECAST OR CAST IN PLACE.
4. ON SHALLOW FILLS, WHERE ENDWALLS ARE 1' OR LESS BELOW SHOULDER LINE, THE TOP OF THE ENDWALL SHALL BE CONSTRUCTED PARALLEL TO THE GRADE OF ROAD.
5. ALL CAST IN PLACE CONCRETE TO BE CLASS A3. FOR PRECAST SEE SHEET 101.16.
6. IN NO CASE SHALL TOP OF ENDWALL PROJECT ABOVE FILL SLOPE, DITCH SLOPE, OR SHOULDER.
7. THIS STANDARD TO BE USED WITH SKEW ANGLES FROM 37° 30' TO 45°.
8. HEADWALL TO BE BEVELED IN ALL AREAS EXCEPT WHERE A CONFLICT WITH INVERT AND WINGWALLS OCCUR.
9. BEVEL EDGE IS REQUIRED ON THE HEADWALL AT THE INLET END OF THE CULVERT (WHERE THE FLOW ENTERS THE CULVERT). HEADWALL AT THE OUTLET END OF THE CULVERT MAY BE EITHER SQUARE EDGE OR BEVEL EDGE.
10. 3/4" CHAMFER MAY BE PROVIDED ON ALL EDGES AT MANUFACTURER'S OPTION.

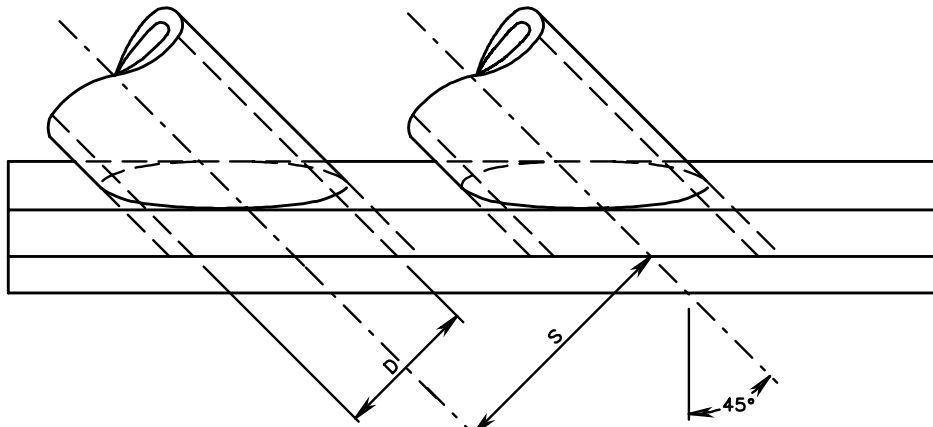

PLAN VIEW

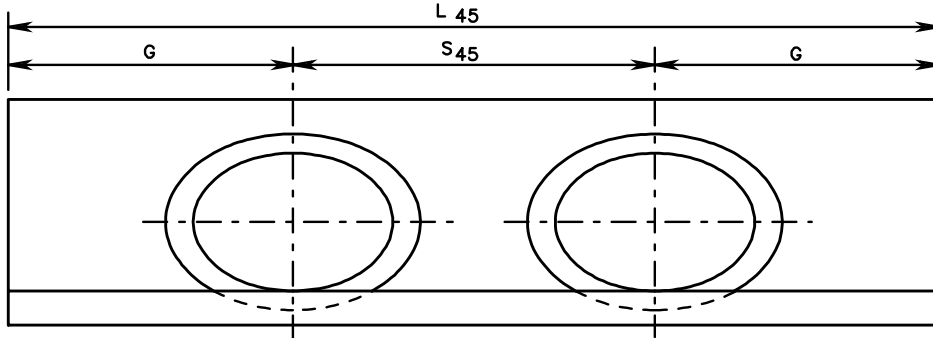

FRONT VIEW

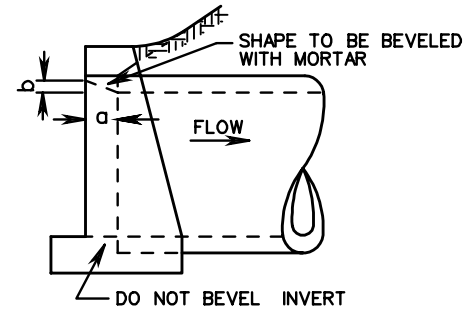

SIDE VIEW

FOR CONCRETE PIPE

D	G	S	S ₄₅	L ₄₅	CONCRETE IN ONE DOUBLE ENDWALL CUBIC YDS.	INCREASE FOR EACH ADDITIONAL PIPE CUBIC YDS.	a	b
12"	2'-0"	1'-10"	2'-7 ¹ / ₈ "	6'-7 ¹ / ₈ "	0.350	0.125	0'-1 ¹ / ₄ "	0'-1"
15"	2'-6"	2'-3"	3'-2 ¹ / ₈ "	8'-2 ¹ / ₈ "	0.714	0.235	0'-1 ³ / ₄ "	0'-1 ¹ / ₄ "
18"	3'-0"	2'-8"	3'-9 ¹ / ₄ "	9'-9 ¹ / ₄ "	0.995	0.346	0'-2"	0'-1 ¹ / ₂ "
21" OR 24"	4'-0"	3'-6"	4'-11 ³ / ₈ "	12'-11 ³ / ₈ "	1.846	0.626	0'-2 ¹ / ₂ "	0'-2"
27" OR 30"	5'-0"	4'-4"	6'-1 ¹ / ₂ "	16'-1 ¹ / ₂ "	2.834	0.937	0'-3 ¹ / ₄ "	0'-2 ¹ / ₂ "
33" OR 36"	6'-0"	5'-2"	7'-3 ⁵ / ₈ "	19'-3 ⁵ / ₈ "	3.966	1.281	0'-3 ³ / ₄ "	0'-3"

FOR CORRUGATED METAL PIPE

D	G	S	S ₄₅	L ₄₅	CONCRETE IN ONE DOUBLE ENDWALL CUBIC YDS.	INCREASE FOR EACH ADDITIONAL PIPE CUBIC YDS.	a	b
12"	2'-0"	1'-7"	2'-2 ⁷ / ₈ "	6'-2 ⁷ / ₈ "	0.369	0.122	0'-1 ¹ / ₄ "	0'-1"
15"	2'-6"	1'-11 ¹ / ₂ "	2'-9 ¹ / ₄ "	7'-9 ¹ / ₄ "	0.746	0.246	0'-1 ³ / ₄ "	0'-1 ¹ / ₄ "
18"	3'-0"	2'-4"	3'-3 ⁵ / ₈ "	9'-3 ⁵ / ₈ "	1.047	0.340	0'-2"	0'-1 ¹ / ₂ "
24"	4'-0"	3'-1"	4'-4 ³ / ₈ "	12'-4 ³ / ₈ "	1.956	0.625	0'-2 ¹ / ₂ "	0'-2"
27" OR 30"	5'-0"	3'-10"	5'-5"	15'-5"	3.030	0.948	0'-3 ¹ / ₄ "	0'-2 ¹ / ₂ "
36"	6'-0"	4'-7"	6'-5 ³ / ₄ "	18'-5 ³ / ₄ "	4.280	1.316	0'-3 ³ / ₄ "	0'-3"



ROAD AND BRIDGE STANDARDS

STANDARD ENDWALLS FOR MULTIPLE PIPE CULVERTS

12" - 36" CIRCULAR PIPES WITH 45° SKEW

VIRGINIA DEPARTMENT OF TRANSPORTATION

SPECIFICATION REFERENCE

105
302

SHEET 2 OF 2

REVISION DATE

101.14

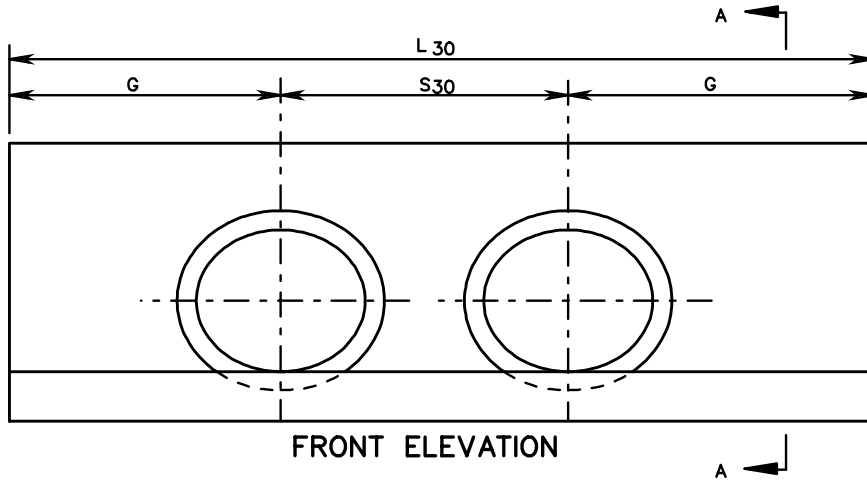
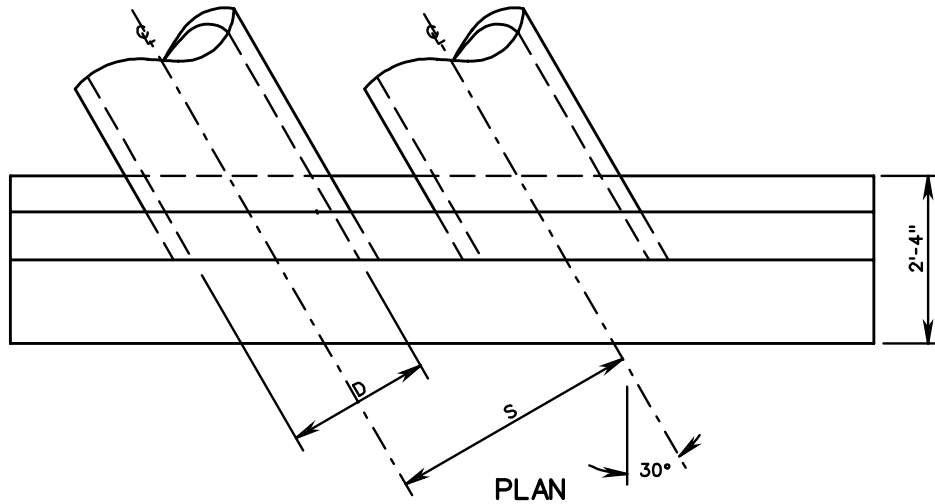

FRONT ELEVATION

FOR CIRCULAR CONCRETE OR CORRUGATED METAL PIPE							
FOR MULTIPLE PIPE ENDWALL							
DIAMETER D OF PIPE	H	L30	S	S30	G	a	b
12"	2'-0"	6'-1 ¹ / ₈ "	1'-10"	2'-1 ¹ / ₈ "	2'-0"	0'-1 ¹ / ₄ "	0'-1"
15"	2'-3"	7'-7 ¹ / ₈ "	2'-3"	2'-7 ¹ / ₈ "	2'-6"	0'-1 ¹ / ₄ "	0'-1 ¹ / ₄ "
18"	2'-6"	9'-1"	2'-8"	3'-1"	3'-0"	0'-2"	0'-1 ¹ / ₂ "
21" OR 24"	3'-2"	12'-0 ¹ / ₂ "	3'-6"	4'-0 ¹ / ₂ "	4'-0"	0'-2 ¹ / ₂ "	0'-2"
27" OR 30"	3'-10"	15'-0"	4'-4"	5'-0"	5'-0"	0'-3 ¹ / ₄ "	0'-2 ¹ / ₂ "
33" OR 36"	4'-4"	17'-11 ¹ / ₈ "	5'-2"	5'-11 ¹ / ₈ "	6'-0"	0'-3 ³ / ₄ "	0'-3"

NOTES:

1. CONCRETE TO BE 4000 PSI MINIMUM COMPRESSIVE STRENGTH.
2. IF PIPE IS TO SKEWED THE OPENING WILL BE ADJUSTED TO ACCOMMODATE ANGLES OF 15° TO 37° 30'.
3. REINFORCING STEEL IN ACCORDANCE WITH ASTM A-615 (REINFORCING BARS).
4. PIPE OPENINGS IN PRECAST DRAINAGE UNITS SHALL NOT EXCEED 4 INCHES AT ANY GIVEN POINT BETWEEN THE PIPE AND THE PRECAST UNIT.
5. DIMENSIONS SHOWN ARE MINIMUM. ACTUAL MEASUREMENTS MAY VARY WITH MANUFACTURER'S TOLERANCE.
6. IN NO CASE SHALL TOP OF ENDWALL PROJECT ABOVE FILL SLOPE, DITCH SLOPE, OR SHOULDER.
7. HEADWALL TO BE BEVELED IN ALL AREAS EXCEPT WHERE A CONFLICT WITH INVERT OR WINGWALL OCCUR.
8. BEVEL EDGE IS REQUIRED ON THE HEADWALL AT THE INLET END OF THE CULVERT (WHERE THE FLOW ENTERS THE CULVERT). HEADWALL AT OUTLET END MAY BE EITHER SQUARE EDGE OR BEVELED.
9. 3/4" CHAMFER MAY BE PROVIDED ON ALL EDGES AT MANUFACTURER'S OPTION.

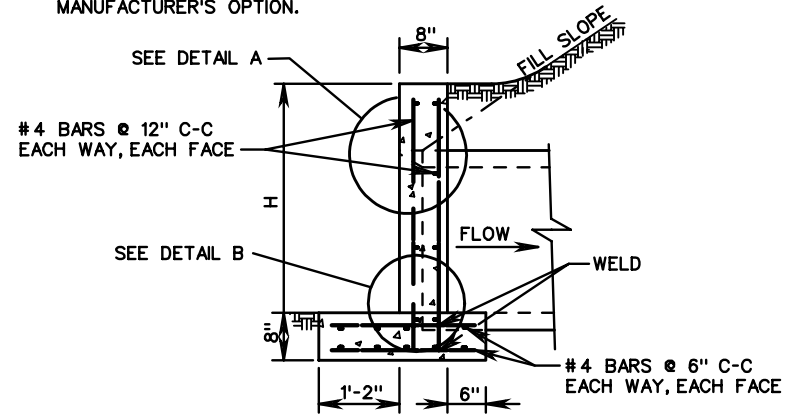

SECTION A-A

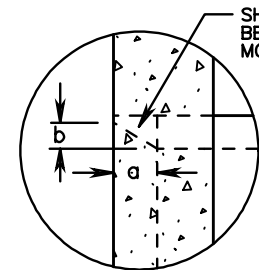

DETAIL A

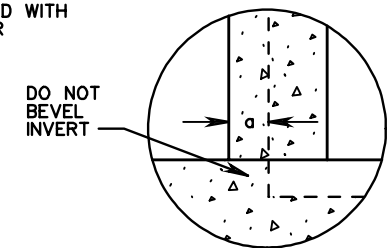

DETAIL B

SPECIFICATION REFERENCE

105
302

PRECAST ENDWALL FOR MULTIPLE PIPE CULVERTS
12" - 36" CIRCULAR PIPES WITH 30° SKEW

VIRGINIA DEPARTMENT OF TRANSPORTATION

VDOT

ROAD AND BRIDGE STANDARDS

REVISION DATE

SHEET 1 OF 1

101.15

NOTES:

1. CONCRETE TO BE 4000 PSI MINIMUM COMPRESSIVE STRENGTH.
2. IF PIPE IS TO SKEWED THE OPENING WILL BE ADJUSTED TO ACCOMMODATE ANGLES OF 37° 30' TO 45°.
3. REINFORCING STEEL IN ACCORDANCE WITH ASTM A-615 (REINFORCING BARS).
4. PIPE OPENINGS IN PRECAST DRAINAGE UNITS SHALL NOT EXCEED 4 INCHES AT ANY GIVEN POINT BETWEEN THE PIPE AND THE PRECAST UNIT.
5. DIMENSIONS SHOWN ARE MINIMUM. ACTUAL MEASUREMENTS MAY VARY WITH MANUFACTURER'S TOLERANCE.
6. IN NO CASE SHALL TOP OF ENDWALL PROJECT ABOVE FILL SLOPE, DITCH SLOPE, OR SHOULDER.
7. HEADWALL TO BE BEVELED IN ALL AREAS EXCEPT WHERE A CONFLICT WITH INVERT OR WINGWALL OCCUR.
8. BEVEL EDGE IS REQUIRED ON THE HEADWALL AT THE INLET END OF THE CULVERT (WHERE THE FLOW ENTERS THE CULVERT). HEADWALL AT OUTLET END MAY BE EITHER SQUARE EDGE OR BEVELED.
9. 3/4" CHAMFER MAY BE PROVIDED ON ALL EDGES AT MANUFACTURER'S OPTION.

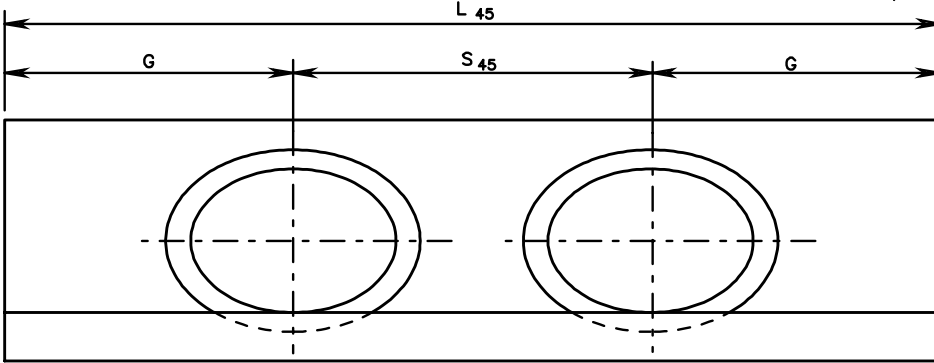
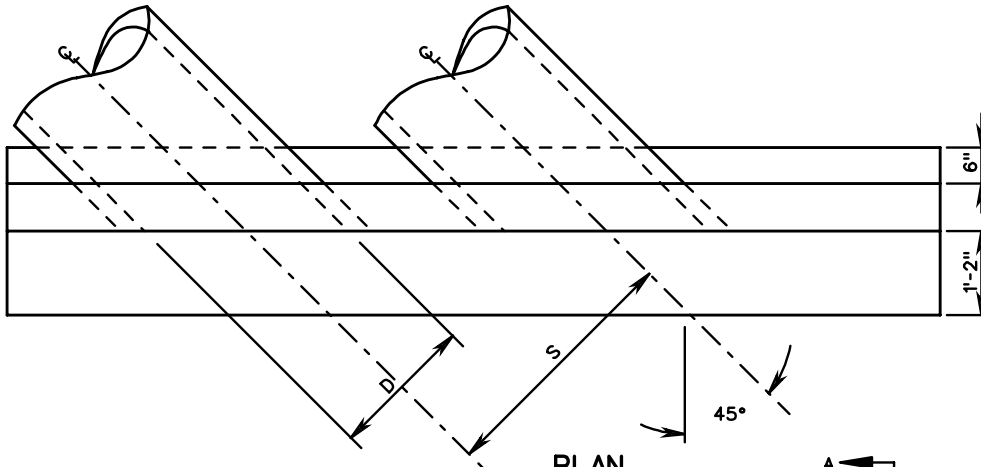

FRONT ELEVATION

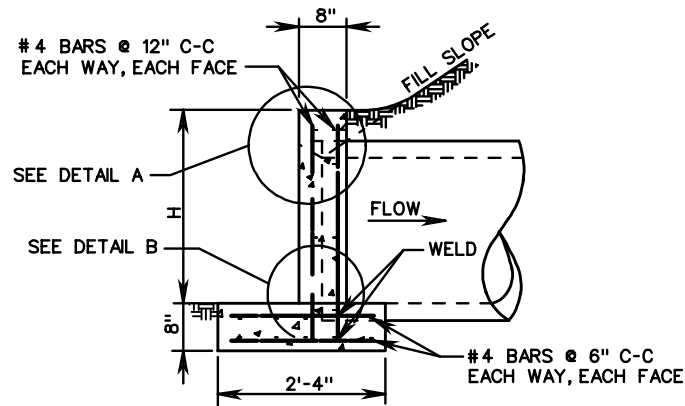

SECTION A-A

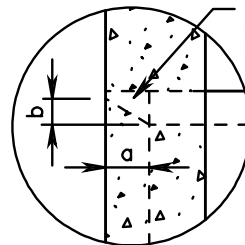

DETAIL A

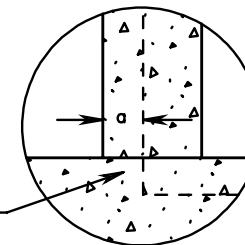

DETAIL B

FOR CIRCULAR CONCRETE OR CORRUGATED METAL PIPE

FOR MULTIPLE PIPE ENDWALL

D	H	L45	S	S45	G	a	b
12"	2'-0"	6'-7 ¹ / ₈ "	1'-10"	2'-7 ¹ / ₈ "	2'-0"	0'-1 ¹ / ₄ "	0'-1"
15"	2'-3"	8'-2 ¹ / ₈ "	2'-3"	3'-2 ¹ / ₈ "	2'-6"	0'-1 ¹ / ₄ "	0'-1 ¹ / ₄ "
18"	2'-6"	9'-9 ¹ / ₄ "	2'-8"	3'-9 ¹ / ₄ "	3'-0"	0'-2"	0'-1 ¹ / ₂ "
21" OR 24"	3'-2"	12'-11 ³ / ₈ "	3'-6"	4'-11 ³ / ₈ "	4'-0"	0'-2 ¹ / ₂ "	0'-2"
27" OR 30"	3'-10"	16'-1 ¹ / ₂ "	4'-4"	6'-1 ¹ / ₂ "	5'-0"	0'-3 ¹ / ₄ "	0'-2 ¹ / ₂ "
33" OR 36"	4'-4"	19'-3 ⁵ / ₈ "	5'-2"	7'-3 ⁵ / ₈ "	6'-0"	0'-4 ¹ / ₂ "	0'-3"



ROAD AND BRIDGE STANDARDS

PRECAST ENDWALL FOR MULTIPLE PIPE CULVERTS

12" - 36" CIRCULAR PIPES FOR 45° SKEW

VIRGINIA DEPARTMENT OF TRANSPORTATION

SPECIFICATION REFERENCE

SHEET 1 OF 1

REVISION DATE

101.16

105
302

NOTES:

1. QUANTITIES GIVEN ARE FOR ONE ENDWALL.
2. PLEASE REFER TO STANDARD EW-2, SHEET 101.04, FOR ALL DIMENSIONS NOT GIVEN IN TABLES.
3. THIS ITEM MAY BE PRECAST OR CAST IN PLACE.
4. ON SHALLOW FILLS, WHERE ENDWALLS ARE 1' OR LESS BELOW SHOULDER LINE, THE TOP OF THE ENDWALL SHALL BE CONSTRUCTED PARALLEL TO THE GRADE OF ROAD.
5. ALL CAST IN PLACE CONCRETE TO BE CLASS A3. FOR PRECAST SEE SHEET 101.18.
6. IN NO CASE SHALL TOP OF ENDWALL PROJECT ABOVE FILL SLOPE, DITCH SLOPE, OR SHOULDER.
7. THIS STANDARD TO BE USED WITH STRAIGHT CROSSINGS AND SKEW ANGLES TO 15°.
8. COST OF BARS FOR CRACK CONTROL TO BE INCLUDED IN PRICE PER BID PER CUBIC YARD CONCRETE.
9. HEADWALL TO BE BEVELED IN ALL AREAS EXCEPT WHERE A CONFLICT WITH INVERT AND WINGWALLS OCCUR.
10. BEVEL EDGE IS REQUIRED ON THE HEADWALL AT THE INLET END OF THE CULVERT (WHERE THE FLOW ENTERS THE CULVERT). HEADWALL AT THE OUTLET END OF THE CULVERT MAY BE EITHER SQUARE EDGE OR BEVEL EDGE.
11. 3/4" CHAMFER MAY BE PROVIDED ON ALL EDGES AT MANUFACTURER'S OPTION.

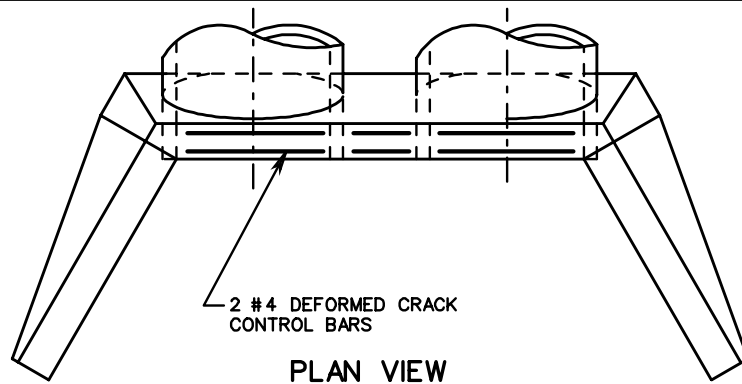

PLAN VIEW

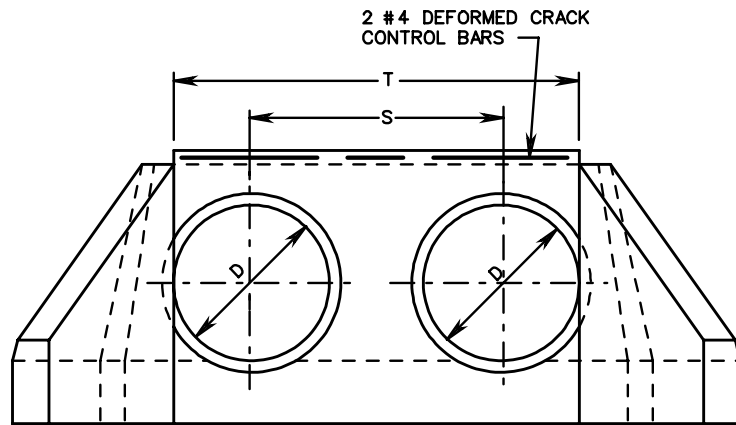

FRONT VIEW

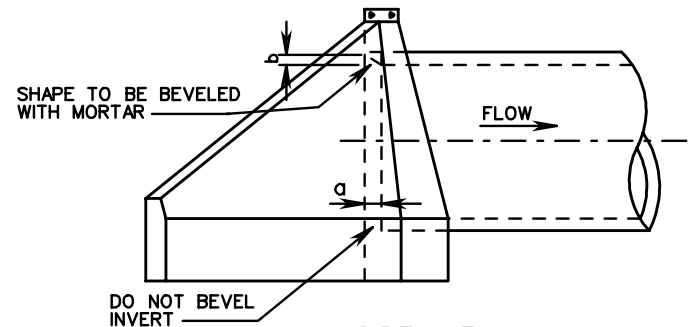

SIDE VIEW

FOR CONCRETE PIPE									
D	S	T	FILL SLOPE 1/2:1		FILL SLOPE 2:1		a	b	
			CONCRETE ONE DBL. ENDWALL CUBIC YARDS	INCREASE FOR EACH ADDITIONAL PIPE CUBIC YDS.	CONCRETE ONE DBL. ENDWALL CUBIC YARDS	INCREASE FOR EACH ADDITIONAL PIPE CUBIC YDS.			
42"	6'-0"	9'-6"	4.829	1.271	5.493	1.255	0'-4 1/2"	0'-3 1/2"	
48"	6'-10"	10'-10"	5.964	1.591	6.802	1.572	0'-5"	0'-4"	
54"	7'-8"	12'-2"	7.692	2.057	8.796	2.035	0'-5 3/4"	0'-4 1/2"	
60"	8'-6"	13'-6"	9.689	2.600	11.112	2.574	0'-6 1/4"	0'-5"	
66"	9'-4"	14'-10"	12.016	3.240	13.811	3.209	0'-7"	0'-5 1/2"	
72"	10'-2"	16'-2"	14.663	3.961	16.885	3.927	0'-7 1/2"	0'-6"	
78"	11'-0"	17'-6"	17.612	4.751	20.325	4.713	0'-8 1/4"	0'-6 1/2"	
84"	11'-10"	18'-10"	21.148	5.696	24.387	5.617	0'-8 3/4"	0'-7"	
90"	12'-8"	20'-2"	25.115	6.920	28.976	6.872	0'-9 1/2"	0'-7 1/2"	
96"	13'-6"	21'-6"	29.439	8.153	33.999	8.101	0'-10"	0'-8"	

FOR CORRUGATED METAL PIPE									
D	S	T	FILL SLOPE 1/2:1		FILL SLOPE 2:1		a	b	
			CONCRETE ONE DBL. ENDWALL CUBIC YARDS	INCREASE FOR EACH ADDITIONAL PIPE CUBIC YDS.	CONCRETE ONE DBL. ENDWALL CUBIC YARDS	INCREASE FOR EACH ADDITIONAL PIPE CUBIC YDS.			
42"	5'-3 1/2"	8'-9 1/2"	5.070	1.279	5.732	1.263	0'-4 1/2"	0'-3 1/2"	
48"	6'-0 1/2"	10'-0 1/2"	6.296	1.616	7.132	1.596	0'-5"	0'-4"	
54"	6'-9 1/2"	11'-3 1/2"	8.228	2.104	9.258	2.081	0'-5 3/4"	0'-4 1/2"	
60"	7'-6 1/2"	12'-6 1/2"	10.319	2.677	11.738	2.650	0'-6 1/4"	0'-5"	
66"	8'-3 1/2"	13'-9 1/2"	12.751	3.261	14.543	3.231	0'-7"	0'-5 1/2"	
72"	9'-0 1/2"	15'-0 1/2"	15.673	4.068	17.889	4.033	0'-7 1/2"	0'-6"	
78"	9'-9 1/2"	16'-3 1/2"	18.918	4.934	21.623	4.893	0'-8 1/4"	0'-6 1/2"	
84"	10'-6 1/2"	17'-6 1/2"	22.733	5.905	25.999	5.860	0'-8 3/4"	0'-7"	
90"	11'-3 1/2"	18'-9 1/2"	26.800	7.076	30.643	7.025	0'-9 1/2"	0'-7 1/2"	
96"	12'-0 1/2"	20'-0 1/2"	31.460	8.353	36.000	8.296	0'-10"	0'-8"	

SPECIFICATION REFERENCE

105
302

STANDARD ENDWALLS FOR MULTIPLE PIPE CULVERTS

42" - 96" CIRCULAR PIPES

VIRGINIA DEPARTMENT OF TRANSPORTATION



ROAD AND BRIDGE STANDARDS

REVISION DATE

SHEET 1 OF 1

101.17

FOR CONCRETE OR CORRUGATED METAL PIPE

PIPE I.D.	H	T	S	1/2:1 SLOPE	2:1 SLOPE	a	b
42"	5'-6"	12'-6"	6'-0"	6'-7 1/2"	8'-8"	0'-4 1/2"	0'-3 1/2"
48"	6'-0"	13'-10"	6'-10"	7'-6"	9'-10"	0'-5"	0'-4"
54"	6'-6"	15'-2"	7'-8"	8'-4 1/2"	11'-0"	0'-5 3/4"	0'-4 1/2"
60"	7'-0"	16'-6"	8'-6"	9'-3"	12'-1 1/2"	0'-6 1/4"	0'-5"
66"	7'-7"	17'-10"	9'-4"	10'-1 1/2"	13'-3 1/2"	0'-7"	0'-5 1/2"
72"	8'-2"	19'-2"	10'-2"	11'-0"	14'-5 1/2"	0'-7"	0'-5 1/2"
78"	8'-8 1/2"	20'-6"	11'-0"	11'-10"	15'-7"	0'-7"	0'-5 1/2"
84"	9'-3"	21'-10"	11'-10"	12'-8 1/2"	16'-9"	0'-7"	0'-5 1/2"
90"	9'-11"	23'-5"	12'-9"	13'-7"	17'-11"	0'-7"	0'-5 1/2"
96"	10'-7"	25'-0"	13'-7"	14'-6"	19'-0 1/2"	0'-7"	0'-5 1/2"

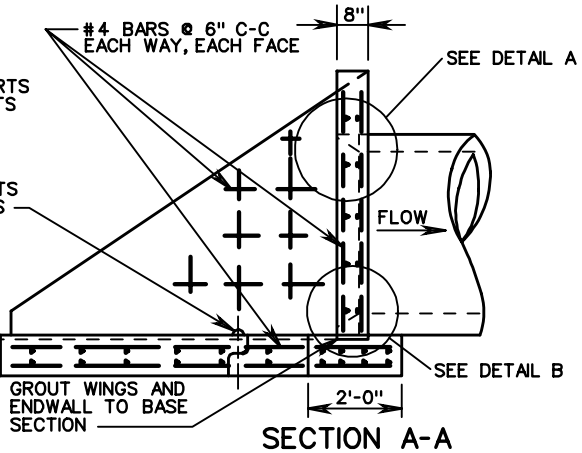
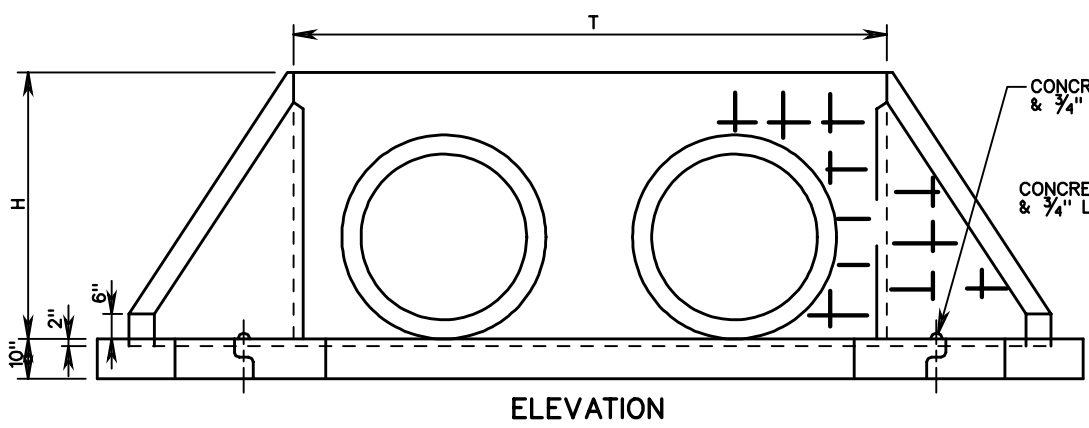
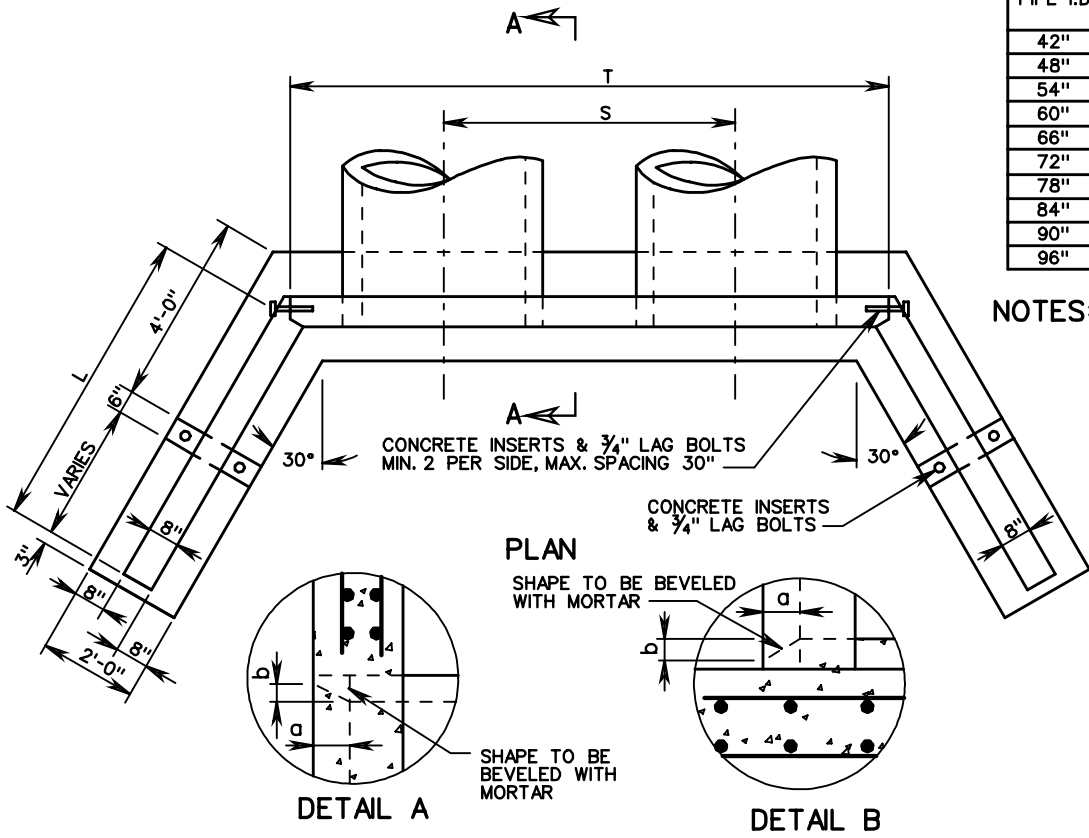

- NOTES:**
1. CONCRETE TO BE 4000 PSI MINIMUM COMPRESSIVE STRENGTH.
 2. IF PIPE IS TO BE SKEWED, THE OPENING WILL BE ADJUSTED TO ACCOMMODATE ANGLES UP TO 15°.
 3. REINFORCING STEEL IN ACCORDANCE WITH ASTM A-615 (REINFORCING BARS).
 4. PIPE OPENINGS IN PRECAST DRAINAGE UNITS SHALL NOT EXCEED 4 INCHES AT ANY GIVEN POINT BETWEEN THE PIPE AND THE PRECAST UNIT.
 5. DIMENSIONS SHOWN ARE MINIMUM. ACTUAL MEASUREMENTS MAY VARY WITH MANUFACTURER'S TOLERANCES.
 6. IN NO CASE SHALL TOP OF ENDWALL PROTRUDE ABOVE FILL SLOPE, DITCH SLOPE, OR SHOULDER.
 7. HEADWALL TO BE BEVELED IN ALL AREAS EXCEPT WHERE A CONFLICT WITH INVERT OR WINGWALL OCCUR.
 8. BEVEL EDGE AS REQUIRED ON THE HEADWALL AT THE INLET END OF THE CULVERT (WHERE THE FLOW ENTERS THE CULVERT).
 9. HEADWALL AT THE OUTLET END OF THE CULVERT MAY BE EITHER SQUARE EDGE OR BEVEL EDGE.
 10. 3/4" CHAMFER MAY BE PROVIDED ON ALL EDGES AT MANUFACTURER'S OPTION.

NOTES:

1. QUANTITIES GIVEN ARE FOR ONE ENDWALL.
2. PLEASE REFER TO STANDARD EW-2S, SHEETS 101.08 AND 101.09, FOR ALL DIMENSIONS NOT GIVEN IN TABLES.
3. THIS ITEM MAY BE PRECAST OR CAST IN PLACE.
4. ON SHALLOW FILLS, WHERE ENDWALLS ARE 1' OR LESS BELOW SHOULDER LINE, THE TOP OF THE ENDWALL SHALL BE CONSTRUCTED PARALLEL TO THE GRADE OF ROAD.
5. ALL CAST IN PLACE CONCRETE TO BE CLASS A3. FOR PRECAST SEE SHEET 101.21.
6. IN NO CASE SHALL TOP OF ENDWALL PROJECT ABOVE FILL SLOPE, DITCH SLOPE, OR SHOULDER.
7. THIS STANDARD TO BE USED WITH SKEW ANGLES FROM 15° TO 37° 30'.
8. COST OF BARS FOR CRACK CONTROL TO BE INCLUDED IN PRICE PER BID PER CUBIC YARD CONCRETE.
9. HEADWALL TO BE BEVELED IN ALL AREAS EXCEPT WHERE A CONFLICT WITH INVERT AND WINGWALLS OCCUR.
10. BEVEL EDGE IS REQUIRED ON THE HEADWALL AT THE INLET END OF THE CULVERT (WHERE THE FLOW ENTERS THE CULVERT). HEADWALL AT THE OUTLET END OF THE CULVERT MAY BE EITHER SQUARE EDGE OR BEVEL EDGE.
11. 3/4" CHAMFER MAY BE PROVIDED ON ALL EDGES AT MANUFACTURER'S OPTION.

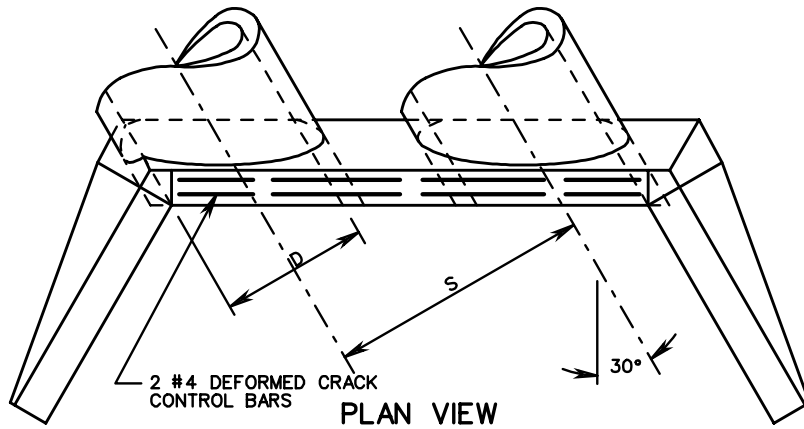

PLAN VIEW

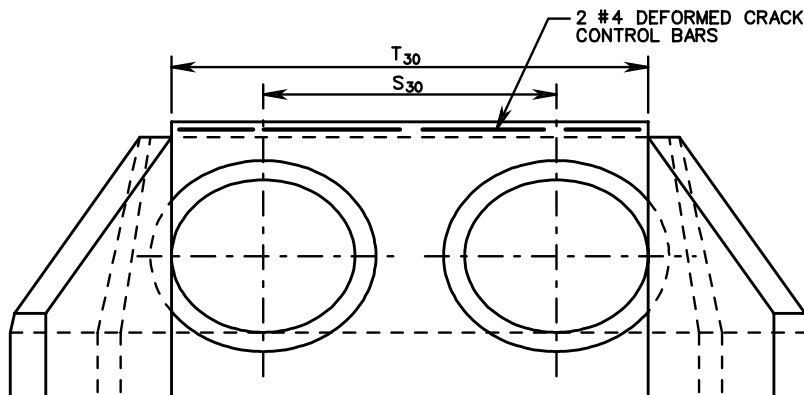

FRONT VIEW

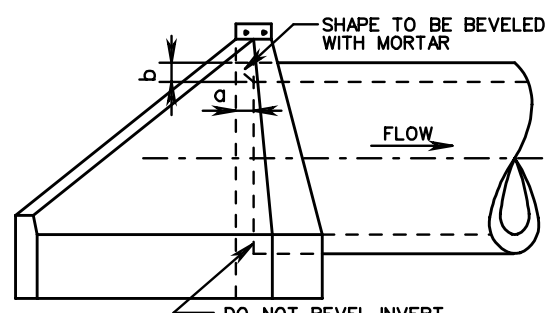

SIDE VIEW

FOR CONCRETE PIPE OR CORRUGATED METAL PIPE		
PIPE I.D.	a	b
42"	0'-4 1/2"	0'-3 1/2"
48"	0'-5"	0'-4"
54"	0'-5 3/4"	0'-4 1/2"
60"	0'-6 1/4"	0'-5"
66"	0'-7"	0'-5 1/2"
72"	0'-7 1/2"	0'-6"
78"	0'-8 1/4"	0'-6 1/2"
84"	0'-8 3/4"	0'-7"
90"	0'-9 1/2"	0'-7 1/2"
96"	0'-10"	0'-8"

FOR CONCRETE PIPE							
D	S	S ₃₀	T ₃₀	FILL SLOPE 1/2:1		FILL SLOPE 2:1	
				CONCRETE IN ONE DOUBLE ENDWALL CUBIC YARDS	INCREASE FOR EACH ADDITIONAL PIPE CUBIC YDS.	CONCRETE IN ONE DOUBLE ENDWALL CUBIC YDS.	INCREASE FOR EACH ADDITIONAL PIPE CUBIC YDS.
42"	6'-0"	6'-11 1/8"	10'-11 5/8"	5.098	1.467	5.759	1.449
48"	6'-10"	7'-10 5/8"	12'-6 1/4"	6.295	1.836	7.129	1.814
54"	7'-8"	8'-10 1/4"	14'-0 5/8"	8.121	2.376	9.218	2.350
60"	8'-6"	9'-9 3/4"	15'-7"	10.224	3.001	11.640	2.971
66"	9'-4"	10'-9 3/8"	17'-1 1/2"	12.663	3.729	14.450	3.693
72"	10'-2"	11'-8 7/8"	18'-8"	15.437	4.552	17.650	4.512
78"	11'-0"	12'-8 3/8"	20'-2 1/2"	18.558	5.482	21.261	5.438
84"	11'-10"	13'-8"	21'-9"	22.081	6.537	25.351	6.488
90"	12'-8"	14'-7 1/2"	23'-3 1/2"	26.445	8.207	30.302	7.934
96"	13'-6"	15'-7"	24'-10"	30.998	9.654	35.556	9.348

FOR CORRUGATED METAL PIPE							
D	S	S ₃₀	T ₃₀	FILL SLOPE 1/2:1		FILL SLOPE 2:1	
				CONCRETE IN ONE DOUBLE ENDWALL CUBIC YDS.	INCREASE FOR EACH ADDITIONAL PIPE CUBIC YDS.	CONCRETE IN ONE DOUBLE ENDWALL CUBIC YDS.	INCREASE FOR EACH ADDITIONAL PIPE CUBIC YDS.
42"	5'-3 1/2"	6'-1 3/8"	10'-1 7/8"	5.364	1.464	6.021	1.445
48"	6'-0 1/2"	6'-11 3/4"	11'-7 1/8"	6.663	1.849	7.494	1.827
54"	6'-9 1/2"	7'-10 3/8"	13'-0 1/2"	8.737	2.409	9.731	2.382
60"	7'-6 1/2"	8'-8 1/2"	14'-5 3/8"	10.927	3.066	12.339	3.035
66"	8'-3 1/2"	9'-6 7/8"	15'-11 1/8"	13.585	3.827	15.354	3.777
72"	9'-0 1/2"	10'-5 1/4"	17'-4 3/8"	16.666	4.738	18.834	4.659
78"	9'-9 1/2"	11'-3 3/8"	18'-9 3/4"	20.066	5.693	22.761	5.647
84"	10'-6 1/2"	12'-2 1/8"	20'-3 3/8"	23.954	6.822	27.214	6.770
90"	11'-3 1/2"	13'-0 1/2"	21'-8 1/2"	28.395	8.174	32.232	8.115
96"	12'-0 1/2"	13'-10 1/8"	23'-1 3/4"	33.328	9.647	37.863	9.582

SPECIFICATION REFERENCE
105
302

STANDARD ENDWALL FOR MULTIPLE PIPE CULVERTS
42" - 96" CIRCULAR PIPES WITH 30° SKEW
VIRGINIA DEPARTMENT OF TRANSPORTATION

VDOT
ROAD AND BRIDGE STANDARDS
REVISION DATE SHEET 1 OF 1
101.19

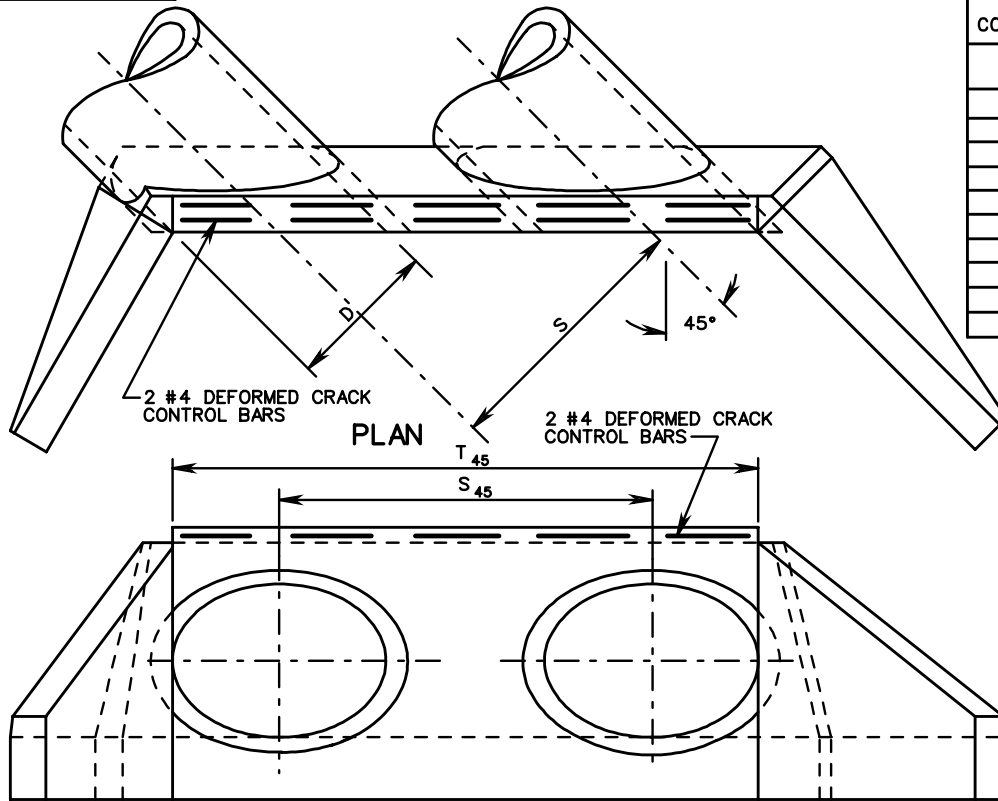

FRONT VIEW

FOR CONCRETE PIPE OR CORRUGATED METAL PIPE		
PIPE I.D.	a	b
42"	0'-4 ¹ / ₂ "	0'-3 ¹ / ₂ "
48"	0'-5"	0'-4"
54"	0'-5 ³ / ₄ "	0'-4 ¹ / ₂ "
60"	0'-6 ¹ / ₄ "	0'-5"
66"	0'-7"	0'-5 ¹ / ₂ "
72"	0'-7 ¹ / ₂ "	0'-6"
78"	0'-8 ¹ / ₄ "	0'-6 ¹ / ₂ "
84"	0'-8 ³ / ₄ "	0'-7"
90"	0'-9 ¹ / ₂ "	0'-7 ¹ / ₂ "
96"	0'-10"	0'-8"

NOTES:

1. QUANTITIES GIVEN ARE FOR ONE ENDWALL.
2. PLEASE REFER TO STANDARD EW-2S, SHEET 101.08 AND 101.09, FOR ALL DIMENSIONS NOT GIVEN IN TABLES.
3. THIS ITEM MAY BE PRECAST OR CAST IN PLACE.
4. ON SHALLOW FILLS, WHERE ENDWALLS ARE 1' OR LESS BELOW SHOULDER LINE, THE TOP OF THE ENDWALL SHALL BE CONSTRUCTED PARALLEL TO THE GRADE OF ROAD.
5. ALL CAST IN PLACE CONCRETE TO BE CLASS A3. FOR PRECAST SEE SHEET 101.21.
6. IN NO CASE SHALL TOP OF ENDWALL PROJECT ABOVE FILL SLOPE, DITCH SLOPE, OR SHOULDER.
7. THIS STANDARD TO BE USED WITH SKEW ANGLES FROM 37° 30' TO 45°.
8. COST OF BARS FOR CRACK CONTROL TO BE INCLUDED IN PRICE BID PER CUBIC YARD CONCRETE.
9. HEADWALL TO BE BEVELED IN ALL AREAS EXCEPT WHERE A CONFLICT WITH INVERT AND WINGWALLS OCCUR.
10. BEVEL EDGE IS REQUIRED ON THE HEADWALL AT THE INLET END OF THE CULVERT (WHERE THE FLOW ENTERS THE CULVERT). HEADWALL AT THE OUTLET END OF THE CULVERT MAY BE EITHER SQUARE EDGE OR BEVEL EDGE.
11. FOR DETAILS OF HEADWALL BEVEL SEE STANDARD EW-2S, SHEETS 101.08 AND 101.09.
12. 3/4" CHAMFER MAY BE PROVIDED ON ALL EDGES AT MANUFACTURER'S OPTION.

FOR CONCRETE PIPE							
D	S	S ₄₅	T ₄₅	FILL SLOPE 1/2:1		FILL SLOPE 2:1	
				CONCRETE IN ONE DOUBLE ENDWALL CUBIC YARDS	INCREASE FOR EACH ADDITIONAL PIPE CUBIC YARDS	CONCRETE IN ONE DOUBLE ENDWALL CUBIC YDS.	INCREASE FOR EACH ADDITIONAL PIPE CUBIC YDS.
42"	6'-0"	8'-5 ¹ / ₈ "	13'-5 ¹ / ₄ "	6.030	1.799	6.819	1.776
48"	6'-10"	9'-8"	15'-3 ¹ / ₈ "	7.443	2.252	8.479	2.225
54"	7'-8"	10'-10 ¹ / ₈ "	17'-2 ¹ / ₂ "	9.621	2.909	10.949	2.878
60"	8'-6"	12'-0 ¹ / ₄ "	19'-1 ¹ / ₈ "	12.124	3.677	13.935	3.640
66"	9'-4"	13'-2 ³ / ₈ "	20'-11 ¹ / ₄ "	15.003	4.562	17.148	4.520
72"	10'-2"	14'-4 ¹ / ₂ "	22'-10 ³ / ₈ "	18.287	5.573	20.953	5.524
78"	11'-0"	15'-6 ⁵ / ₈ "	24'-9"	21.991	6.715	25.247	6.662
84"	11'-10"	16'-8 ¹ / ₈ "	26'-7 ⁵ / ₈ "	26.158	8.008	30.089	7.947
90"	12'-8"	17'-11"	28'-6 ¹ / ₄ "	31.209	9.789	35.937	9.779
96"	13'-6"	19'-1 ¹ / ₈ "	30'-4 ¹ / ₈ "	36.640	11.533	42.212	11.523

FOR CORRUGATED METAL PIPE							
D	S	S ₄₅	T ₄₅	FILL SLOPE 1/2:1		FILL SLOPE 2:1	
				CONCRETE IN ONE DOUBLE ENDWALL CUBIC YDS.	INCREASE FOR EACH ADDITIONAL PIPE CUBIC YDS.	CONCRETE IN ONE DOUBLE ENDWALL CUBIC YDS.	INCREASE FOR EACH ADDITIONAL PIPE CUBIC YDS.
42"	5'-3 ¹ / ₂ "	7'-5 ³ / ₄ "	12'-5 ¹ / ₄ "	6.331	1.789	7.118	1.767
48"	6'-0 ¹ / ₂ "	8'-6 ¹ / ₈ "	14'-2 ³ / ₄ "	7.866	2.262	8.900	2.236
54"	6'-9 ¹ / ₂ "	9'-7 ¹ / ₄ "	15'-11 ⁵ / ₈ "	10.223	2.949	11.526	2.917
60"	7'-6 ¹ / ₂ "	10'-8"	17'-8 ¹ / ₈ "	12.944	3.755	14.750	3.717
66"	8'-3 ¹ / ₂ "	11'-8 ³ / ₄ "	19'-6"	16.090	4.690	18.236	4.646
72"	9'-0 ¹ / ₂ "	12'-9 ¹ / ₂ "	21'-3 ¹ / ₄ "	19.690	5.763	22.347	5.712
78"	9'-9 ¹ / ₂ "	13'-10 ¹ / ₈ "	23'-0 ¹ / ₂ "	23.757	6.974	27.003	6.917
84"	10'-6 ¹ / ₂ "	14'-10 ¹ / ₈ "	24'-9 ¹ / ₄ "	28.347	8.350	32.265	8.284
90"	11'-3 ¹ / ₂ "	15'-11 ⁵ / ₈ "	26'-7"	33.600	10.007	38.292	9.983
96"	12'-0 ¹ / ₂ "	17'-0 ³ / ₈ "	28'-4 ¹ / ₈ "	39.499	11.815	45.031	11.790



ROAD AND BRIDGE STANDARDS

SHEET 1 OF 1

REVISION DATE

101.20

STANDARD ENDWALLS FOR MULTIPLE PIPE CULVERTS

42" - 96" CIRCULAR PIPE WITH 45° SKEW

VIRGINIA DEPARTMENT OF TRANSPORTATION

SPECIFICATION REFERENCE

105
302

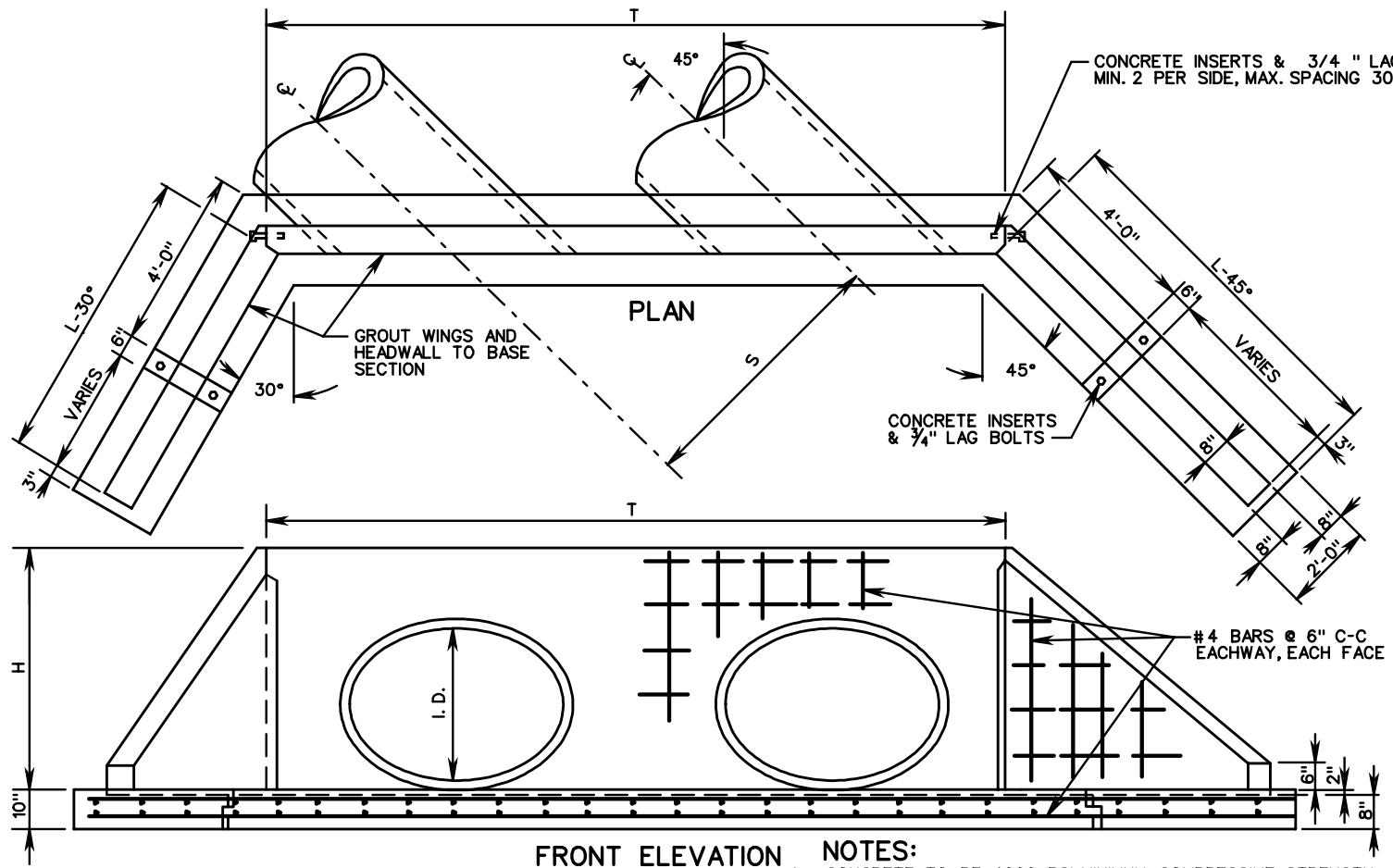

- NOTES:**
1. CONCRETE TO BE 4000 PSI MINIMUM COMPRESSIVE STRENGTH.
 2. FOR DETAILS OF HEADWALL BEVEL SEE STANDARD EW-2SPC, SHEET 101.10.
 3. REINFORCING STEEL IN ACCORDANCE WITH ASTM A-615 (REINFORCING BARS).
 4. PIPE OPENINGS IN PRECAST DRAINAGE UNITS SHALL NOT EXCEED 4 INCHES AT ANY GIVEN POINT BETWEEN THE PIPE AND THE PRECAST UNIT.
 5. DIMENSIONS SHOWN ARE MINIMUM. ACTUAL MEASUREMENTS MAY VARY WITH MANUFACTURER'S TOLERANCES.
 6. IN NO CASE SHALL TOP OF ENDWALL PROTRUDE ABOVE FILL SLOPE, DITCH SLOPE, OR SHOULDER.
 7. HEADWALL TO BE BEVELED IN ALL AREAS EXCEPT WHERE A CONFLICT WITH INVERT OR WINGWALL OCCUR.
 8. BEVEL EDGE AS REQUIRED ON THE HEADWALL AT THE INLET END OF THE CULVERT (WHERE THE FLOW ENTERS THE CULVERT).
 9. HEADWALL AT THE OUTLET END OF THE CULVERT MAY BE EITHER SQUARE EDGE OR BEVEL EDGE.
 10. 3/4" CHAMFER MAY BE PROVIDED ON ALL EDGES AT MANUFACTURER'S OPTION.

FOR CIRCULAR CONCRETE OR CORRUGATED METAL PIPE

DIMENSIONS									
PIPE I.D.	H	T	S	L-30° 1/2:1 SLOPE	L-30° 2:1 SLOPE	L-45° 1/2:1 SLOPE	L-45° 2:1 SLOPE	a	b
42"	5'-6"	16'-6"	6'-0"	6'-7 1/2"	8'-8"	8'-0"	10'-6"	0'-4 1/2"	0'-3 1/2"
48"	6'-0"	18'-4"	6'-10"	7'-6"	9'-9 3/4"	9'-2 1/2"	12'-0"	0'-5"	0'-4"
54"	6'-6"	20'-3"	7'-8"	8'-4 1/2"	10'-11 1/2"	10'-3"	13'-6"	0'-5 3/4"	0'-4 1/2"
60"	7'-0"	22'-2"	8'-6"	9'-3"	12'-1 1/4"	11'-3 1/2"	14'-10 1/4"	0'-6 1/4"	0'-5"
66"	7'-7"	24'-0"	9'-4"	10'-1 1/4"	13'-3 1/2"	12'-4 1/2"	16'-4"	0'-7"	0'-5 1/2"
72"	8'-2"	25'-11"	10'-2"	11'-0"	14'-5 1/2"	13'-5 1/2"	17'-8"	0'-7"	0'-5 1/2"
78"	8'-8 1/2"	27'-10"	11'-0"	11'-10"	15'-7"	14'-6"	19'-0"	0'-7"	0'-5 1/2"
84"	9'-3"	29'-8"	11'-10"	12'-8 1/2"	16'-9"	15'-6"	20'-6"	0'-7"	0'-5 1/2"
90"	9'-11"	31'-8"	12'-8"	13'-7"	17'-11"	16'-7 1/2"	21'-11"	0'-7"	0'-5 1/2"
96"	10'-7"	33'-8"	13'-6"	14'-5 1/4"	19'-1"	17'-8 1/4"	23'-4"	0'-7"	0'-5 1/2"

SPECIFICATION REFERENCE
105
302

PRECAST ENDWALLS FOR MULTIPLE PIPE CULVERTS

42" - 96" CIRCULAR PIPES WITH 45° SKEW

VIRGINIA DEPARTMENT OF TRANSPORTATION



ROAD AND BRIDGE STANDARDS

REVISION DATE SHEET 1 OF 1

101.21

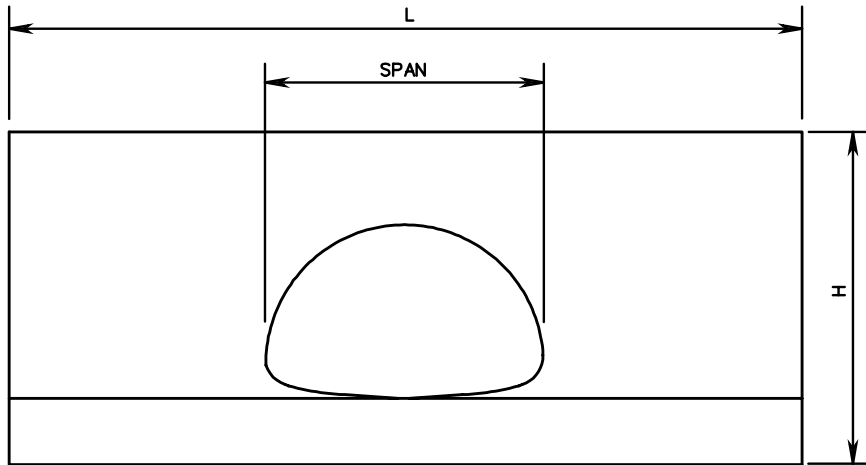

FRONT ELEVATION

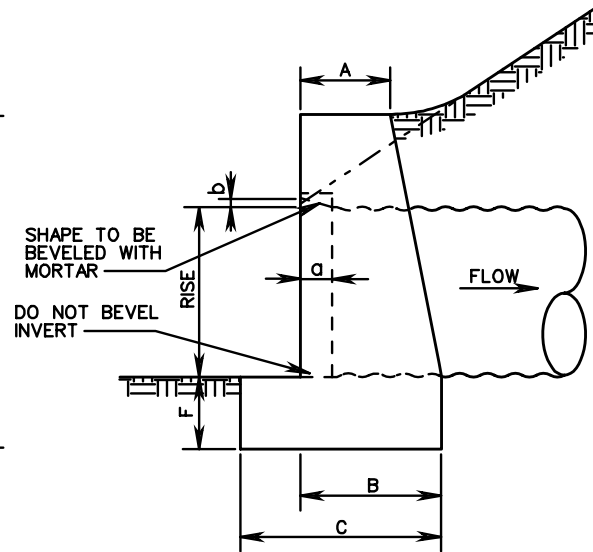

SIDE ELEVATION

NOTES:

1. THIS ITEM MAY BE PRECAST OR CAST IN PLACE.
2. ON SHALLOW FILLS, WHERE ENDWALLS ARE 1' OR LESS BELOW SHOULDER LINE, THE TOP OF THE ENDWALL SHALL BE CONSTRUCTED PARALLEL TO THE GRADE OF ROAD.
3. ALL CAST IN PLACE CONCRETE TO BE CLASS A3. FOR PRECAST SEE SHEET 101.23.
4. IN NO CASE SHALL TOP OF ENDWALL PROJECT ABOVE FILL SLOPE, DITCH SLOPE, OR SHOULDER.
5. HEADWALL TO BE BEVELED IN ALL AREAS EXCEPT WHERE A CONFLICT WITH INVERT AND WINGWALLS OCCUR.
6. BEVEL EDGE IS REQUIRED ON THE HEADWALL AT THE INLET END OF THE CULVERT (WHERE THE FLOW ENTERS THE CULVERT). HEADWALL AT THE OUTLET END OF THE CULVERT MAY BE EITHER SQUARE EDGE OR BEVEL EDGE.
7. 3/4" CHAMFER MAY BE PROVIDED ON ALL EDGES AT MANUFACTURER'S OPTION.

CORRUGATED METAL PIPE										
NOMINAL DIMENSIONS OF PIPE ARCH		DIMENSIONS FOR ONE SINGLE ENDWALL						CUBIC YARDS CONCRETE FOR ONE ENDWALL	a	b
SPAN	RISE	A	B	C	F	H	L			
17"	13"	0'-6"	0'-11"	1'-4"	0'-6"	2'-2"	4'-3"	0.258	0'-2"	0'-1/4"
21"	15"	0'-6"	0'-11"	1'-4"	0'-6"	2'-4"	5'-1"	0.322	0'-2 1/2"	0'-1 1/2"
24"	18"	0'-8"	1'-1 1/2"	1'-7"	0'-8"	3'-0"	6'-1"	0.626	0'-3"	0'-2"
28"	20"	0'-9"	1'-3"	1'-9"	0'-8"	3'-2"	6'-11"	0.823	0'-3"	0'-2"
35"	24"	0'-11"	1'-6"	2'-2"	0'-9"	3'-7"	8'-6"	1.371	0'-4"	0'-2 1/2"
42"	29"	1'-0"	1'-9"	2'-6"	0'-9"	4'-0"	10'-4"	2.072	0'-4 1/2"	0'-3"
*40"	31"									
49"	33"	1'-0"	1'-9"	2'-6"	0'-9"	4'-4"	11'-11"	2.520	0'-5 1/2"	0'-3 1/2"
*46"	36"									
57"	38"	1'-0"	2'-0"	2'-9"	0'-9"	4'-9"	13'-10"	3.427	0'-6"	0'-4"
*53"	41"									

*3" x 1" AND 5" x 1" CORRUGATION DIMENSIONS.



ROAD AND BRIDGE STANDARDS

STANDARD ENDWALLS FOR PIPE ARCHES

SPECIFICATION REFERENCE

SHEET 1 OF 1

REVISION DATE

13" - 38" RISE

105
302

101.22

VIRGINIA DEPARTMENT OF TRANSPORTATION

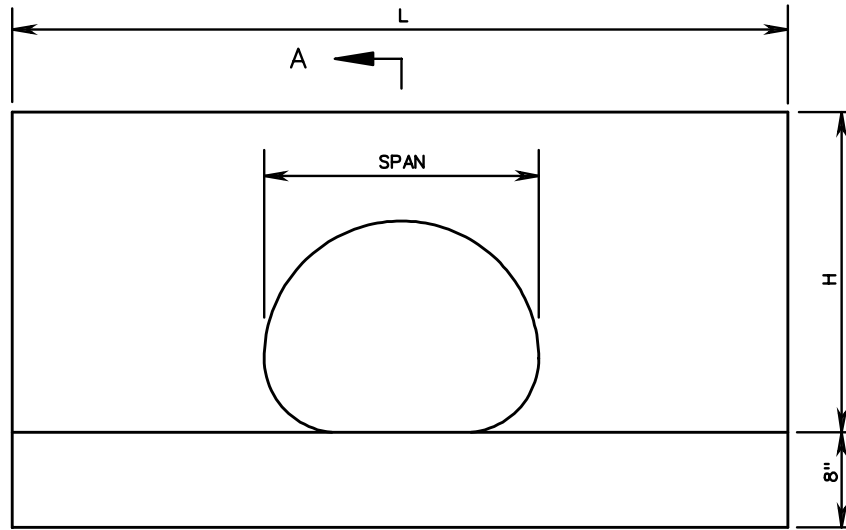

A ←
FRONT ELEVATION

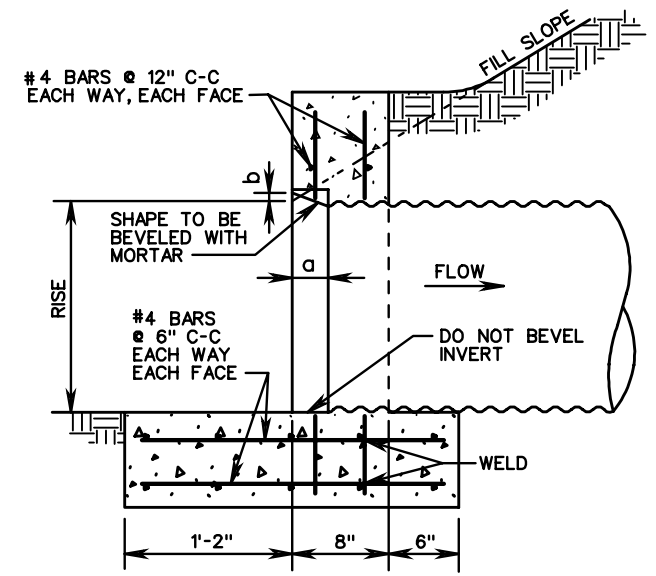

SECTION A-A

NOTES:

1. CONCRETE TO BE 4000 PSI MINIMUM COMPRESSIVE STRENGTH.
2. IF PIPE IS TO BE SKEWED THE OPENING WILL BE ADJUSTED TO ACCOMMODATE.
3. REINFORCING STEEL IN ACCORDANCE WITH ASTM A-615 (REINFORCING BARS).
4. PIPE ARCH OPENINGS IN PRECAST DRAINAGE UNITS SHALL NOT EXCEED 4 INCHES AT ANY GIVEN POINT BETWEEN THE PIPE AND THE PRECAST UNIT.
5. DIMENSIONS SHOWN ARE MINIMUM. ACTUAL MEASUREMENTS MAY VARY WITH MANUFACTURER'S TOLERANCE.
6. IN NO CASE SHALL TOP OF ENDWALL PROJECT ABOVE FILL SLOPE, OR SHOULDER.
7. HEADWALL TO BE BEVELED IN ALL AREAS EXCEPT WHERE A CONFLICT WITH INVERT OR WINGWALL OCCUR.
8. BEVEL EDGE IS REQUIRED ON THE HEADWALL AT THE INLET END OF THE CULVERT HEADWALL AT OUTLET END MAY BE EITHER SQUARE EDGE OR BEVELED.
9. 3/4" CHAMFER MAY BE PROVIDED ON ALL EDGES AT MANUFACTURER'S OPTION.

PRECAST ENDWALL DIMENSIONS					
SPAN	RISE	H	L	a	b
17"	13"	1'-8"	4'-0"	0'-2"	0'-1/4"
21"	15"	1'-10"	5'-0"	0'-2 1/2"	0'-1 1/2"
24"	18"	2'-4"	6'-0"	0'-3"	0'-2"
28"	20"	2'-6"	7'-0"	0'-3"	0'-2"
35"	24"	2'-10"	8'-0"	0'-4"	0'-2 1/2"
* 40"	31"	3'-3"	10'-0"	0'-4 1/2"	0'-3"
42"	29"				
* 46"	36"	3'-7"	12'-0"	0'-5 1/2"	0'-3 1/2"
49"	33"				
* 53"	41"	4'-0"	13'-0"	0'-6"	0'-4"
57"	38"				

* DIMENSIONS FOR 3" x 1" AND 5" x 1" CORRUGATIONS

SPECIFICATION REFERENCE 105 302	<h2 style="margin: 0;">PRECAST ENDWALLS FOR PIPE ARCHES</h2> <p style="margin: 0;">13" - 38" RISE</p> <p style="margin: 0;">VIRGINIA DEPARTMENT OF TRANSPORTATION</p>	ROAD AND BRIDGE STANDARDS REVISION DATE SHEET 1 OF 1 101.23
---	---	--

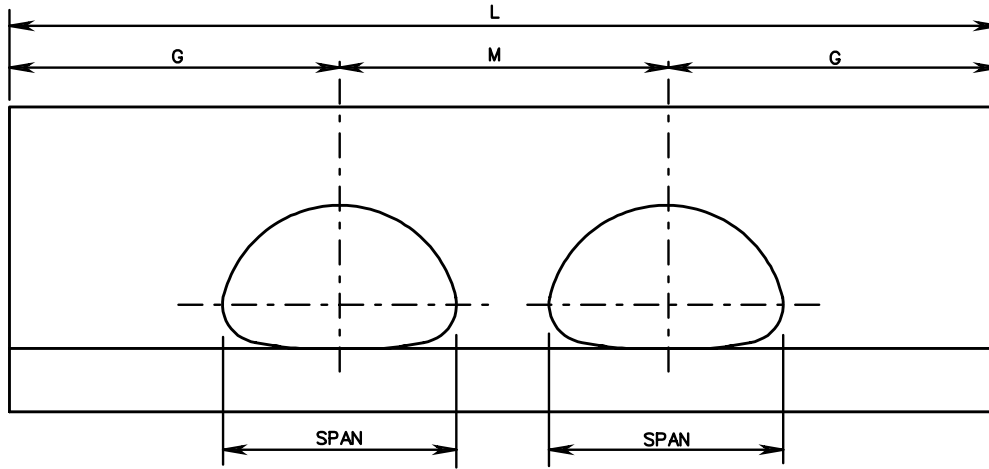

FRONT ELEVATION

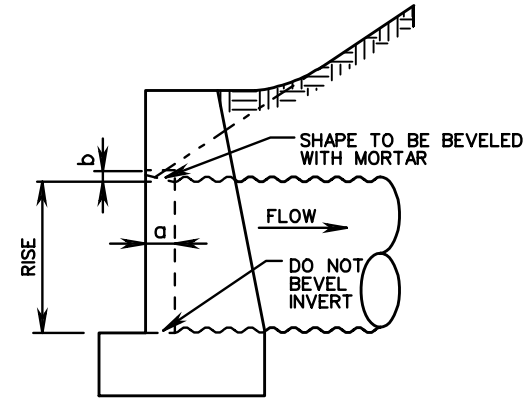

SIDE ELEVATION

NOTES:

1. THIS ITEM MAY BE PRECAST OR CAST IN PLACE.
2. REFER TO STANDARD EW-9, SHEET 101.22, FOR ALL DIMENSIONS NOT GIVEN IN TABLE.
3. ON SHALLOW FILLS, WHERE ENDWALLS ARE 1' OR LESS BELOW SHOULDER LINE, THE TOP OF THE ENDWALL SHALL BE CONSTRUCTED PARALLEL TO THE GRADE OF ROAD.
4. ALL CAST IN PLACE CONCRETE TO BE CLASS A3. FOR PRECAST SEE SHEET 101.25.
5. IN NO CASE SHALL TOP OF ENDWALL PROJECT ABOVE FILL SLOPE, DITCH SLOPE, OR SHOULDER.
6. HEADWALL TO BE BEVELED IN ALL AREAS EXCEPT WHERE A CONFLICT WITH INVERT AND WINGWALLS OCCUR.
7. BEVEL EDGE IS REQUIRED ON THE HEADWALL AT THE INLET END OF THE CULVERT (WHERE THE FLOW ENTERS THE CULVERT). HEADWALL AT THE OUTLET END OF THE CULVERT MAY BE EITHER SQUARE EDGE OR BEVEL EDGE.
8. 3/4" CHAMFER MAY BE PROVIDED ON ALL EDGES AT MANUFACTURER'S OPTION.

CORRUGATED METAL PIPE

NOMINAL DIMENSIONS OF PIPE ARCH		DIMENSIONS FOR ONE DOUBLE ENDWALL			CUBIC YARDS CONCRETE		a	b
SPAN	RISE	M	G	L	ONE DOUBLE ENDWALL	INCREASE FOR EACH ADDITIONAL PIPE ARCH		
17"	13"	2'-6"	2'-2"	6'-10"	0.402	0.138	0'-2"	0'-1 1/4"
21"	15"	2'-10"	2'-7"	8'-0"	0.487	0.159	0'-2 1/2"	0'-1 1/2"
24"	18"	3'-1"	3'-1"	9'-3"	0.913	0.277	0'-3"	0'-2"
28"	20"	3'-5"	3'-6"	10'-5"	1.182	0.348	0'-3"	0'-2"
35"	24"	4'-0"	4'-3"	12'-6"	1.900	0.529	0'-4"	0'-2 1/2"
42"	29"	4'-10"	5'-2"	15'-2"	2.852	0.780	0'-4 1/2"	0'-3"
* 40"	31"							
49"	33"	5'-7"	6'-0"	17'-7"	3.455	0.924	0'-5 1/2"	0'-3 1/2"
* 46"	36"							
57"	38"	6'-6"	6'-11"	20'-4"	4.664	1.237	0'-6"	0'-4"
* 53"	41"							

* 3" X 1" AND 5" X 1" CORRUGATION DIMENSIONS.



ROAD AND BRIDGE STANDARDS

STANDARD ENDWALLS FOR MULTIPLE PIPE ARCHES

13" - 38" RISE

VIRGINIA DEPARTMENT OF TRANSPORTATION

SPECIFICATION REFERENCE

105
302

SHEET 1 OF 1

REVISION DATE

101.24

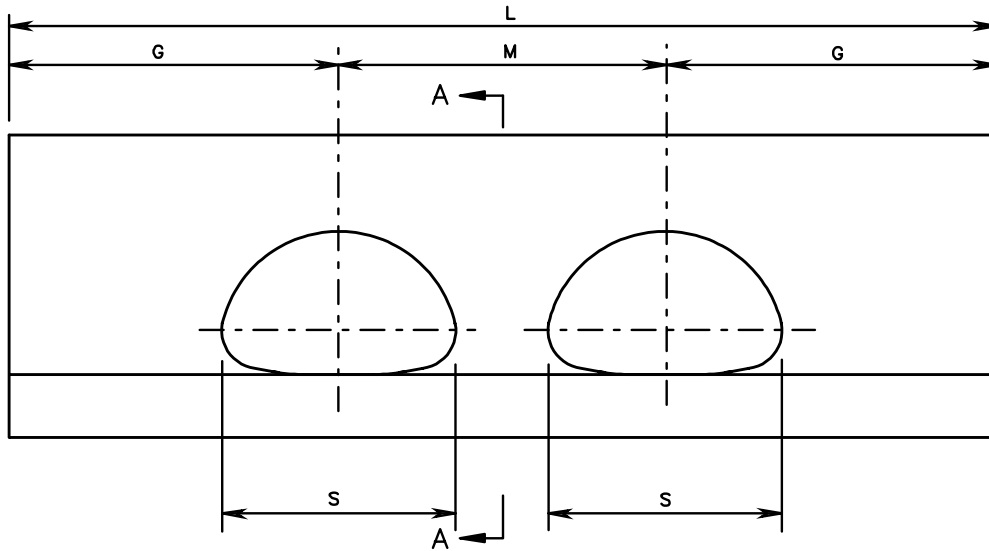

FRONT ELEVATION

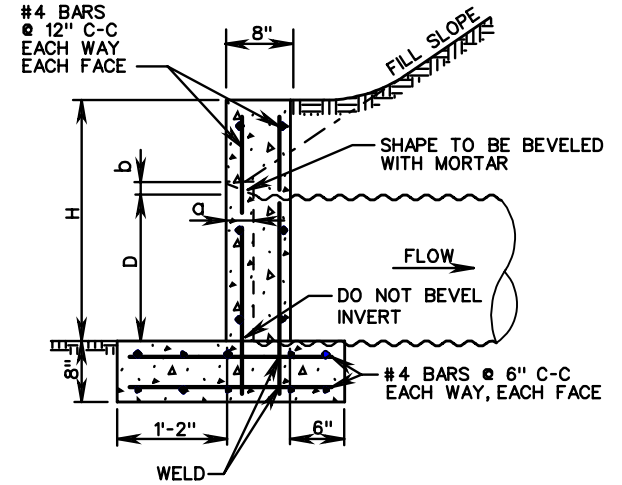

SECTION A-A

NOTES:

1. CONCRETE TO BE 4000 PSI MINIMUM COMPRESSIVE STRENGTH.
2. IF PIPE IS TO BE SKEWED THE OPENING WILL BE ADJUSTED TO ACCOMMODATE.
3. REINFORCING STEEL IN ACCORDANCE WITH ASTM A-615 (REINFORCING BARS).
4. PIPE ARCH OPENINGS IN PRECAST DRAINAGE UNITS SHALL NOT EXCEED 4 INCHES AT ANY GIVEN POINT BETWEEN THE PIPE AND THE PRECAST UNIT.
5. DIMENSIONS SHOWN ARE MINIMUM. ACTUAL MEASUREMENTS MAY VARY WITH MANUFACTURER'S TOLERANCE.
6. IN NO CASE SHALL TOP OF ENDWALL PROJECT ABOVE FILL SLOPE, OR SHOULDER.
7. HEADWALL TO BE BEVELED IN ALL AREAS EXCEPT WHERE A CONFLICT WITH INVERT OR WINGWALL OCCUR.
8. BEVEL EDGE IS REQUIRED ON THE HEADWALL AT THE INLET END OF THE CULVERT HEADWALL AT OUTLET END MAY BE EITHER SQUARE EDGE OR BEVELED.
9. 3/4" CHAMFER MAY BE PROVIDED ON ALL EDGES AT MANUFACTURER'S OPTION.

PRECAST ENDWALL DIMENSIONS

S	D	M	G	L	H	a	b
17"	13"	2'-6"	2'-2"	6'-10"	2'-3"	0'-2"	0'-1/4"
21"	15"	2'-10"	2'-7"	8'-0"	2'-5"	0'-2 1/2"	0'-1 1/2"
24"	18"	3'-1"	3'-1"	9'-3"	2'-8"	0'-3"	0'-2"
28"	20"	3'-5"	3'-6"	10'-5"	2'-10"	0'-3"	0'-2"
35"	24"	4'-0"	4'-3"	12'-6"	3'-2"	0'-4"	0'-2 1/2"
* 40"	31"	4'-10"	5'-2"	15'-2"	3'-7"	0'-4 1/2"	0'-3"
42"	29"						
* 46"	36"	5'-7"	6'-0"	17'-7"	3'-11"	0'-5 1/2"	0'-3 1/2"
49"	33"						
* 53"	41"	6'-6"	6'-11"	20'-4"	4'-4"	0'-6"	0'-4"
57"	38"						

* DIMENSIONS FOR 3" X 1" AND 5" X 1" CORRUGATION

SPECIFICATION REFERENCE

105
302

PRECAST ENDWALLS FOR MULTIPLE PIPE ARCHES
13" - 38" RISE

VIRGINIA DEPARTMENT OF TRANSPORTATION

VDOT

ROAD AND BRIDGE STANDARDS

REVISION DATE

SHEET 1 OF 1

101.25

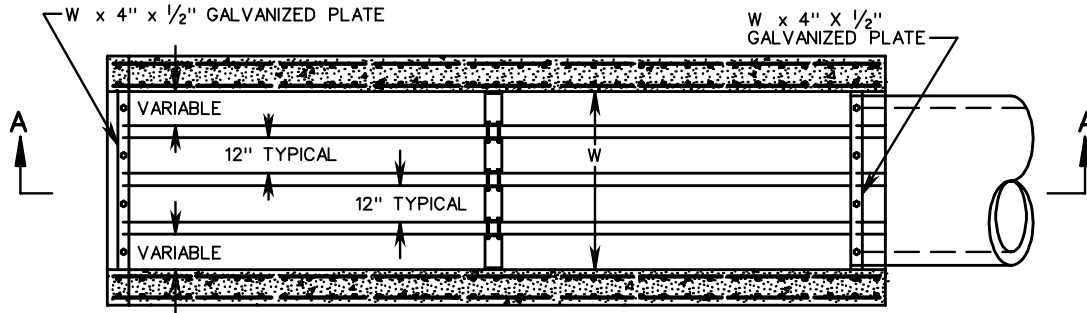

PLAN VIEW

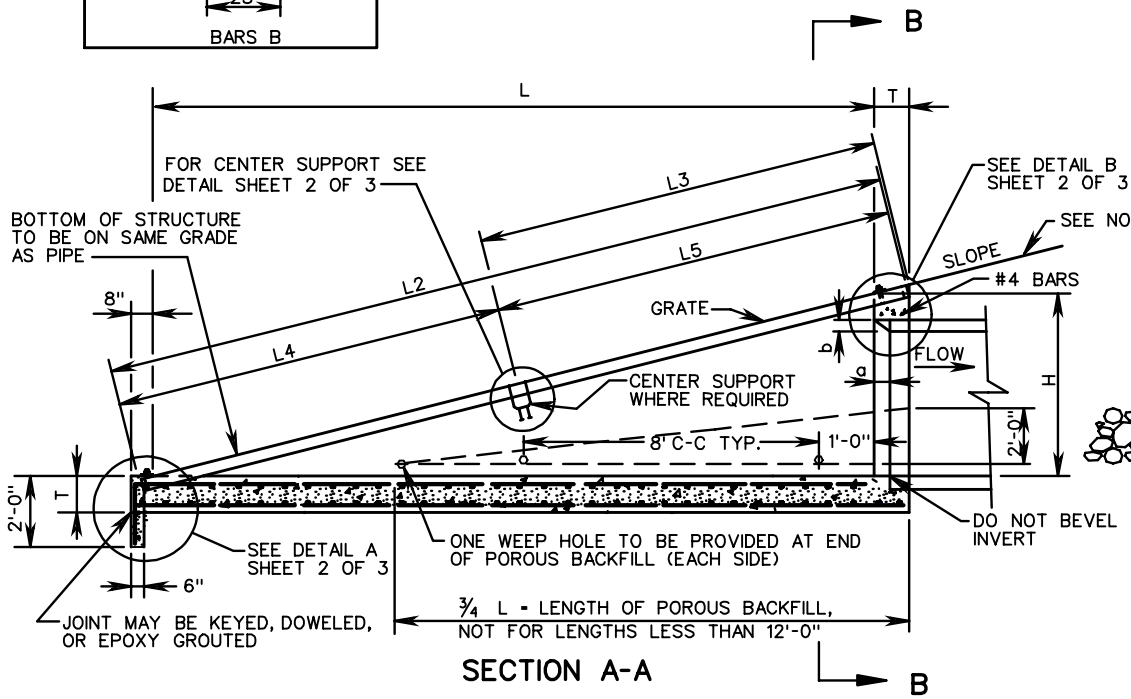
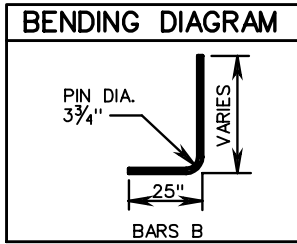

SECTION A-A

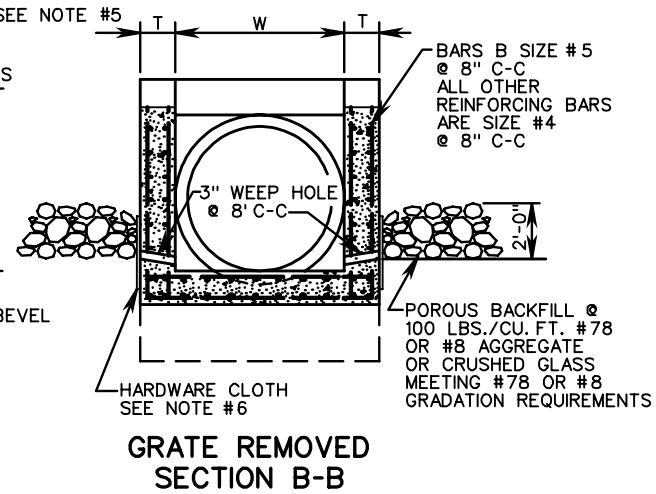

GRATE REMOVED SECTION B-B

NOTES:

1. THIS ITEM MAY BE PRECAST OR CAST IN PLACE. ALL CAST CONCRETE TO BE CLASS A3, FOR PRECAST USE 4000 PSI MINIMUM. REINFORCING STEEL TO HAVE A MINIMUM 1/2" COVER.
2. FOR TABULATION OF DIMENSIONS AND QUANTITIES SEE SHEET 3 OF 3.
3. ALL PIPE FOR GRATE, STRUCTURAL TUBING, AND RELATED HARDWARE TO BE GALVANIZED.
4. STANDARD EW-11 TO BE INSTALLED SO THE GRATE CONFIGURATION IS ALWAYS PERPENDICULAR TO THE EDGE OF THE SHOULDER.
5. SLOPE AS SPECIFIED ON TYPICAL SECTION.
6. WEEP HOLE WITH 12" X 12" PLASTIC HARDWARE CLOTH 1/4" MESH OR GALVANIZED STEEL WIRE, MINIMUM WIRE DIAMETER 0.03" NUMBER 4 MESH HARDWARE CLOTH ANCHORED FIRMLY OUTSIDE OF STRUCTURE.
7. HEADWALL TO BE BEVELED IN ALL AREAS EXCEPT WHERE A CONFLICT WITH INVERT OR WINGWALLS OCCUR.
8. BEVEL EDGE IS REQUIRED ON THE HEADWALL OF THE INLET END OF THE CULVERT (WHERE THE FLOW ENTERS THE CULVERT).
9. HEADWALL AT THE OUTLET END OF THE CULVERT MAY BE EITHER SQUARE EDGE OR BEVEL EDGE.
10. 3/4" CHAMFER MAY BE PROVIDED ON ALL EDGES AT MANUFACTURER'S OPTION.
11. IN NO CASE SHALL THE TOP OF THE ENDWALL PROJECT ABOVE FILL SLOPE, DITCH SLOPE OR SHOULDER



ROAD AND BRIDGE STANDARDS

PIPE ENDWALL WITH LOAD-CARRYING GRATE

12" - 60" CIRCULAR PIPES

VIRGINIA DEPARTMENT OF TRANSPORTATION

SPECIFICATION REFERENCE

105
233
302

SHEET 1 OF 3

REVISION DATE

101.26

* STRUCTURAL TUBING TO BE EXTENDED TO WITHIN 2" OF OUTSIDE FACE OF SIDEWALL

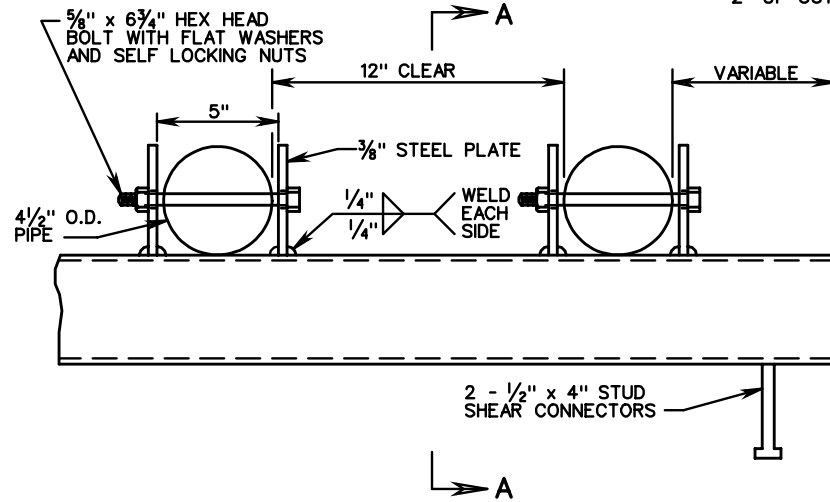

CENTER SUPPORT
(ELEVATION)

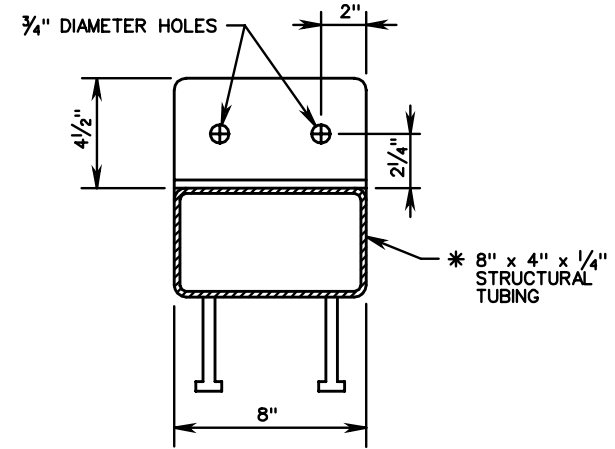

SECTION A-A

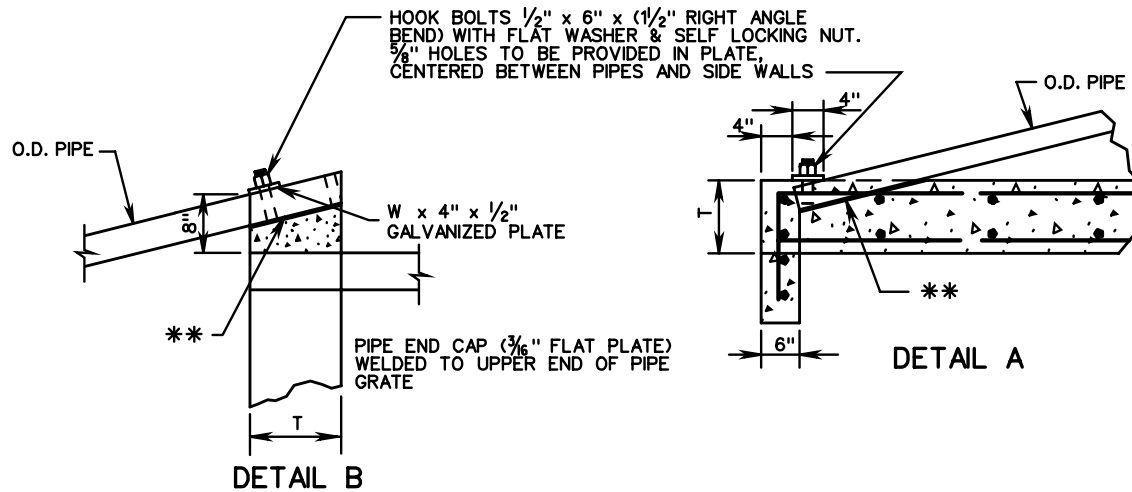

DETAIL B

DETAIL A

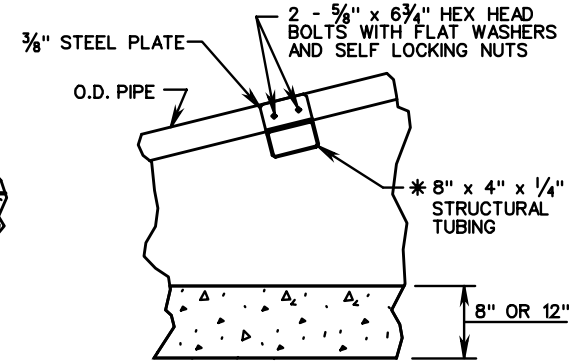

CENTER SUPPORT

** NOTCHES FOR PIPE TO BE FORMED IN CONCRETE SO THAT PIPE WILL FIT SNUG BUT CAN BE REMOVED.

SPECIFICATION REFERENCE

105
233
302

PIPE ENDWALL WITH LOAD-CARRYING GRATE

12" - 60" CIRCULAR PIPES

VIRGINIA DEPARTMENT OF TRANSPORTATION

VDOT

ROAD AND BRIDGE STANDARDS

REVISION DATE

SHEET 2 OF 3

101.27

PIPE GRATE

TYPE I - 3/2" O.D.
 TYPE II - 4" O.D.
 TYPE III - 4 1/2" O.D.

LENGTH OF GRATE TO BE DETERMINED
 BY L₂ x NUMBER OF PIPES REQUIRED

4 : 1 SLOPE										
PIPE SIZE	H	L	W	T						
					PIPE O.D.	NO. PIPES REQUIRED	L ₂	L ₃	L ₄	L ₅
12"	1'-10"	7'-4"	2'-0"	8"	3 1/2"	1	8'-6 3/4"	NO CENTER SUPPORT REQUIRED		
15" or 18"	2'-4 1/2"	9'-6"	2'-0"	8"	3 1/2"	1	10'-9 1/2"			
21" or 24"	2'-11"	11'-8"	3'-0"	8"	4"	2	13'-0 1/4"			
27" or 30"	3'-5 1/2"	13'-10"	3'-0"	8"	4"	2	15'-3"			
33" or 36"	4'-0"	16'-0"	4'-0"	8"	4 1/2"	3	17'-6"			
42"	4'-6 1/2"	18'-2"	4'-0"	12"	4 1/2"	3	19'-8 3/4"			
48"	5'-1"	20'-4"	5'-0"	12"	4 1/2"	3	22'-2 5/8"	10'-5 1/4"	11'-10 1/2"	10'-4 1/4"
54"	5'-7 1/2"	22'-6"	6'-0"	12"	4 1/2"	4	24'-5 1/2"	12'-8 1/8"	11'-10 1/2"	12'-7 1/8"
60"	6'-2"	24'-8"	6'-0"	12"	4 1/2"	4	26'-8 1/2"	14'-11"	11'-10 1/2"	14'-10"

DIMENSIONS FOR BEVEL ON HEADWALL

PIPE I.D.	a	b
12"	0'-1 1/4"	0'-1"
15" or 18"	0'-2"	0'-1 1/2"
21" or 24"	0'-2 1/2"	0'-2"
27" or 30"	0'-3 1/4"	0'-2 1/2"
33" or 36"	0'-3 3/4"	0'-3"
42"	0'-4 1/2"	0'-3 1/2"
48"	0'-5"	0'-4"
54"	0'-5 3/4"	0'-4 1/2"
60"	0'-6 1/4"	0'-5"

6 : 1 SLOPE										
PIPE SIZE	H	L	W	T						
					PIPE O.D.	NO. PIPES REQUIRED	L ₂	L ₃	L ₄	L ₅
12"	1'-10"	11'-0"	2'-0"	8"	3 1/2"	1	12'-1 1/4"	NO CENTER SUPPORT REQUIRED		
15" or 18"	2'-4 1/2"	14'-3"	2'-0"	8"	4"	1	15'-5 1/4"			
21" or 24"	2'-11"	17'-6"	3'-0"	8"	4 1/2"	2	18'-9"			
27" or 30"	3'-5 1/2"	20'-9"	3'-0"	8"	4 1/2"	2	22'-0"	4'-8 1/8"	17'-4 1/2"	4'-7 1/2"
33" or 36"	4'-0"	24'-0"	4'-0"	8"	4 1/2"	3	25'-3 3/8"	7'-11 5/8"	17'-4 1/2"	7'-11"
42"	4'-6"	27'-3"	4'-0"	12"	4 1/2"	3	28'-11"	11'-7 1/4"	17'-4 1/2"	11'-6 1/2"
48"	5'-1"	30'-6"	5'-0"	12"	4 1/2"	3	32'-2"	14'-10 3/4"	17'-4 1/2"	14'-10 1/8"
54"	5'-7 1/2"	33'-9"	6'-0"	12"	4 1/2"	4	35'-6"	18'-2 1/4"	17'-4 1/2"	18'-1 1/2"
60"	6'-2"	37'-0"	6'-0"	12"	4 1/2"	4	38'-9 1/2"	19'-5 1/2"	19'-4 3/4"	19'-4 3/4"

3 : 1 SLOPE

PIPE SIZE	H	L	W	T	PIPE GRATE			NO CENTER SUPPORT REQUIRED
					PIPE O.D.	NO. PIPES REQUIRED	L ₂	
15" or 18"	2'-4 1/2"	7'-1 1/2"	2'-0"	8"	3 1/2"	1	8'-6 1/4"	
21" or 24"	2'-11"	8'-9"	3'-0"	8"	3 1/2"	2	10'-2 3/4"	
27" or 30"	3'-5 1/2"	10'-4 1/2"	3'-0"	8"	3 1/2"	2	11'-11 1/4"	
33" or 36"	4'-0"	12'-0"	4'-0"	8"	4"	3	13'-7 3/4"	
42"	4'-6 1/2"	13'-7 1/2"	4'-0"	12"	4"	3	15'-4 1/4"	
48"	5'-1"	15'-3"	5'-0"	12"	4 1/2"	3	17'-0 1/2"	
54"	5'-7 1/2"	16'-10 1/2"	6'-0"	12"	4 1/2"	4	18'-9 1/2"	
60"	6'-2"	18'-6"	6'-0"	12"	4 1/2"	4	20'-6"	

APPROXIMATE QUANTITIES

PIPE SIZE	3 : 1			PIPE SIZE	4 : 1			PIPE SIZE	6 : 1		
	CONCRETE CUBIC YARDS		lbs. REINF. STEEL		CONCRETE CUBIC YARDS		lbs. REINF. STEEL		CONCRETE CUBIC YARDS		lbs. REINF. STEEL
	CONC. PIPE	C.M. PIPE			CONC. PIPE	C.M. PIPE			CONC. PIPE	C.M. PIPE	
12"	.95	.97	240	12"	1.17	1.18	308	12"	1.64	1.66	443
15" or 18"	1.27	1.29	328	15" or 18"	1.59	1.61	425	15" or 18"	2.28	2.31	618
21" or 24"	2.30	2.35	483	21" or 24"	2.44	2.49	628	21" or 24"	3.55	3.59	917
27" or 30"	2.38	2.44	608	27" or 30"	3.01	3.01	788	27" or 30"	4.35	4.41	1157
33" or 36"	3.28	3.38	809	33" or 36"	4.20	4.29	1059	33" or 36"	6.01	6.09	1556
42"	6.27	6.46	1050	42"	8.05	8.22	1368	42"	11.59	11.76	1997
48"	8.07	8.29	1327	48"	10.29	10.50	1647	48"	14.84	15.04	2514
54"	10.02	10.29	1612	54"	12.80	13.06	2105	54"	18.47	18.73	3094
60"	11.18	11.50	1826	60"	14.36	14.68	2391	60"	20.82	21.14	3517



ROAD AND BRIDGE STANDARDS

PIPE ENDWALL WITH LOAD-CARRYING GRATE

12" - 60" CIRCULAR PIPES

VIRGINIA DEPARTMENT OF TRANSPORTATION

SPECIFICATION REFERENCE

105
233
302

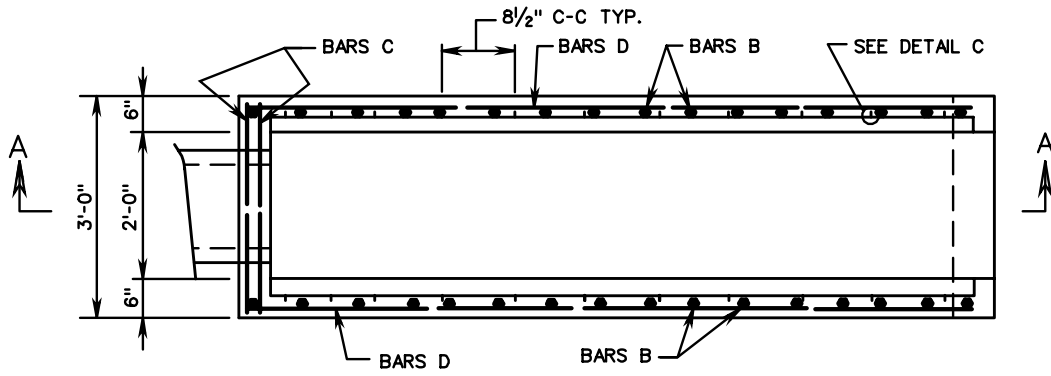

PLAN VIEW
(GRATE REMOVED)

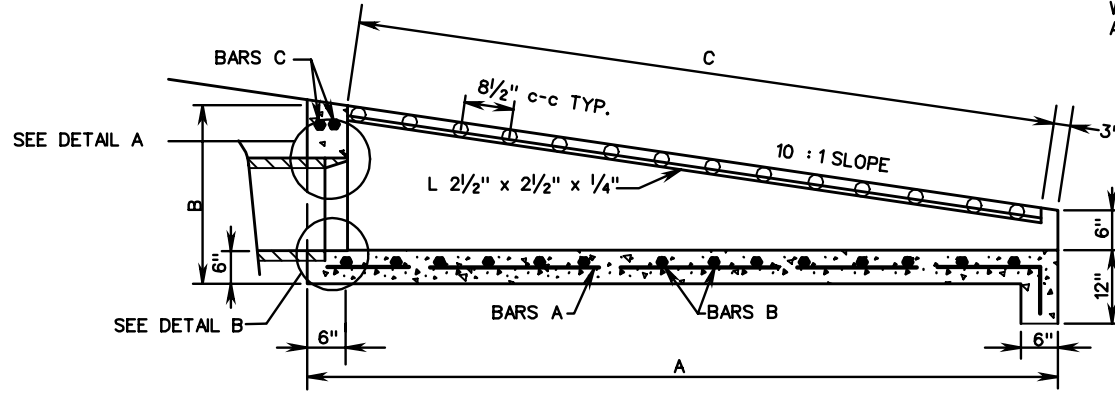

SECTION A-A

DIMENSIONS FOR BEVEL		
ON HEADWALL PIPE SIZE	a	b
12"	0'-1 1/4"	0'-1"
15"	0'-1 3/4"	0'-1 1/4"
18"	0'-2"	0'-1 1/2"
21" OR 24"	0'-2 1/2"	0'-2"

NO HOLES ARE TO BE PROVIDED IN L 2" x 2" x 3/8" WHEN SOLID BARS ARE USED.

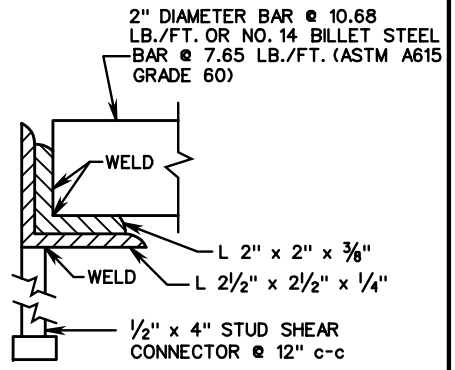

DETAIL C

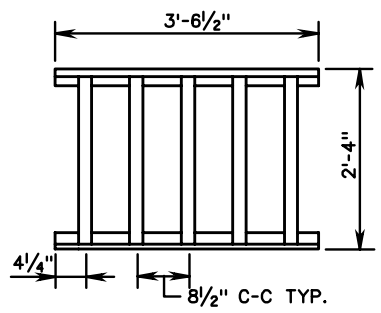

GRATE SECTION DETAIL

NOTES:

1. IN NO CASE SHALL TOP OF ENDWALL PROJECT ABOVE FILL SLOPE, DITCH, SLOPE, OR SHOULDER.
2. CLASS A3 CONCRETE TO BE USED IF CAST IN PLACE, 4000 PSI IF PRECAST.
3. REINFORCING STEEL TO HAVE A MINIMUM 1 1/2" CONCRETE COVER. FOR SCHEDULE OF REINFORCING STEEL, DIMENSIONS, AND QUANTITIES SEE SHEET 2 OF 2.
4. THIS ITEM MAY BE PRECAST OR CAST IN PLACE.
5. BOTTOM OF STRUCTURE TO BE ON THE SAME GRADE AS DRAINAGE DITCH.
6. 3/4" CHAMFER MAY BE PROVIDED ON ALL EDGES AT MANUFACTURER'S OPTION.
7. HEADWALL TO BE BEVELED IN ALL AREAS EXCEPT WHERE A CONFLICT WITH INVERT OR WINGWALLS OCCUR.
8. BEVEL EDGE IS REQUIRED ON HEADWALL AT THE INLET END OF THE CULVERT (WHERE THE FLOW ENTERS THE CULVERT). HEADWALL AT THE OUTLET END OF THE CULVERT MAY BE SQUARE EDGE OR BEVEL EDGE.
9. THE NUMBER OF GRATE SECTIONS TO BE USED FOR EACH EW-11A IS BASED ON THE LENGTH "C" SEE QUANTITIES CHART ON SHEET 2 OF 2.

SHAPE TO BE BEVELED WITH MORTAR

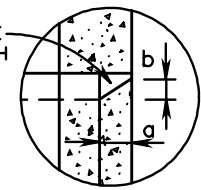

DETAIL A

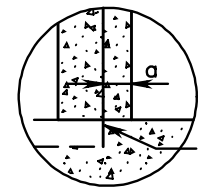

DETAIL B

SPECIFICATION REFERENCE
105 233 302

PIPE ENDWALL WITH LOAD-CARRYING GRATE
12" - 24" CIRCULAR PIPES
VIRGINIA DEPARTMENT OF TRANSPORTATION

VDOT ROAD AND BRIDGE STANDARDS	
REVISION DATE	SHEET 1 OF 2
101.29	

DIMENSIONS

PIPE SIZE	A	B	C	a	b
12"	11'-4"	2'-1"	10'-7½"	0'-1¼"	0'-1"
15"	14'-8"	2'-5"	14'-0"	0'-1¾"	0'-1¼"
18"	17'-2"	2'-8"	16'-6"	0'-2"	0'-1½"
21" OR 24"	22'-2"	3'-2"	21'-6½"	0'-2½"	0'-2"

APPROXIMATE QUANTITIES

PIPE SIZE	NO. OF GRATE SECTIONS	CONCRETE CUBIC YARDS		LBS. REINF. STEEL	LENGTH TO BE CUT FROM 1 GRATE
		CONC. PIPE	C.M. PIPE		
12"	3	1.127	1.139	119	0
15"	4	1.532	1.547	161	2½"
18"	5	1.856	1.877	201	1'-2½"
21" OR 24"	6	2.567	2.600	276	* 0

* GRATES WILL BE 3⅝" SHORT.

SCHEDULE OF REINFORCING STEEL

PIPE SIZE	BARS A				BARS B				BARS C				BARS D			
	SIZE	NO.	SPA.	LENGTH	SIZE	NO.	SPA.	LENGTH	SIZE	NO.	SPA.	LENGTH	SIZE	NO.	SPA.	LENGTH
12"	# 4	5	8"	11'-6"	# 4	17	8"	VARIES 3'-8" TO 5'-10"	# 4	2	-	4'-8"	# 4	4	8"	VARIES 4'-2" TO 11'-0"
15"	# 4	5	8"	14'-10"	# 4	22	8"	VARIES 3'-8" TO 6'-7"	# 4	2	-	4'-8"	# 4	4	8"	VARIES 7'-8" TO 14'-4"
18"	# 4	5	8"	17'-4"	# 4	26	8"	VARIES 3'-8" TO 7'-0"	# 4	2	-	4'-8"	# 4	6	8"	VARIES 4'-4" TO 16'-10"
21" OR 24"	# 4	5	8"	22'-4"	# 4	33	8"	VARIES 3'-8" TO 8'-0"	# 4	2	-	4'-8"	# 4	8	8"	VARIES 2'-9" TO 21'-10"

BENDING DIAGRAM

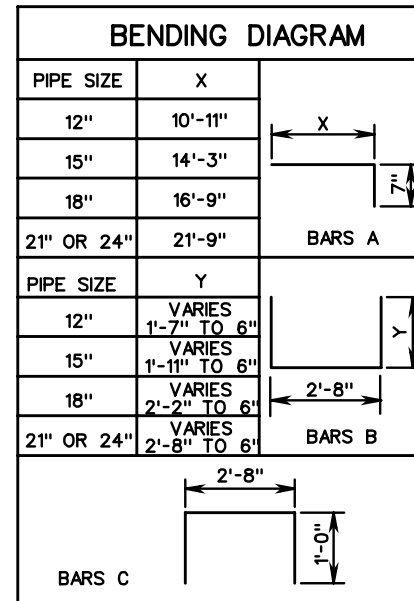

APPROXIMATE WEIGHT OF GRATE

TYPE	LBS.
2" DIA. BAR	158.55
NO. 14 BILLET STEEL BAR	123.64



ROAD AND BRIDGE STANDARDS

PIPE ENDWALL WITH LOAD-CARRYING GRATE

12" - 24" CIRCULAR PIPES

VIRGINIA DEPARTMENT OF TRANSPORTATION

SPECIFICATION REFERENCE

105
233
302

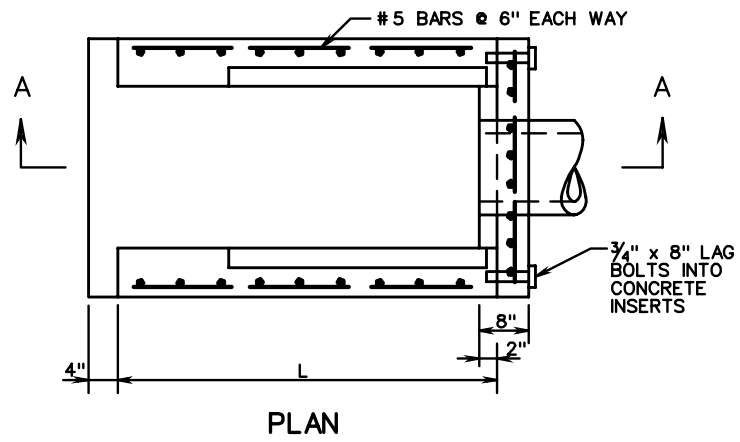

PLAN

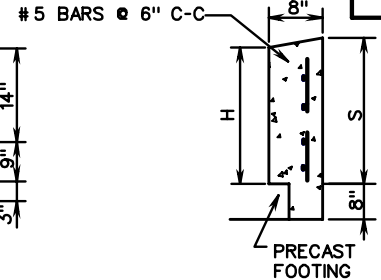
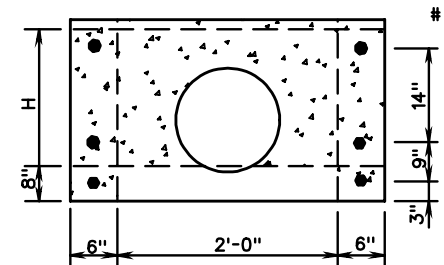

PRECAST FOOTING

DIMENSIONS		
PIPE SIZE	H	S
12"	1'-7"	1'-7 3/4"
15"	1'-11"	1'-11 3/4"
18"	2'-2"	2'-2 3/4"
21" OR 24"	2'-8"	2'-8 3/4"

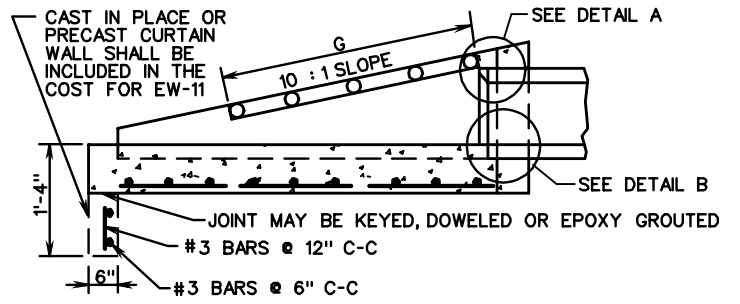

SECTION A-A

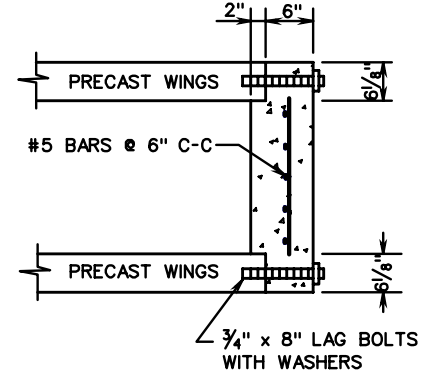

END WALL DETAIL

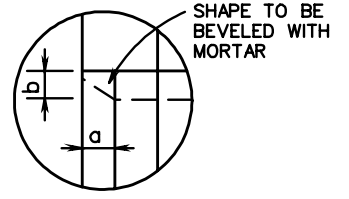

DETAIL A

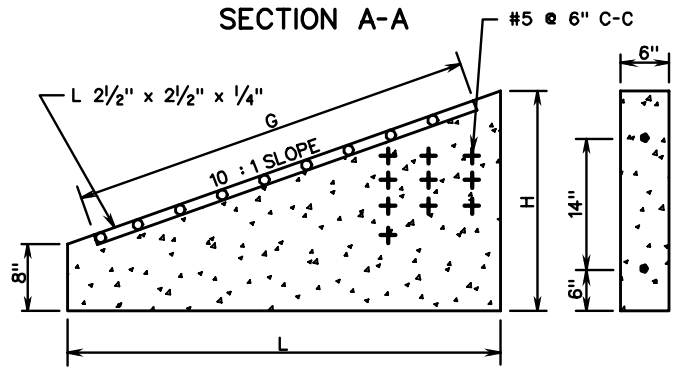

WING WALL DETAIL

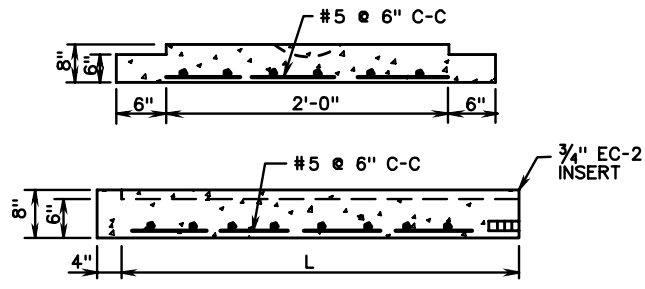

FOOTING DETAIL

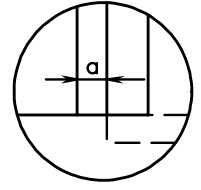

DETAIL B

DIMENSIONS					
PIPE SIZE	L	H	G	a	b
12"	11'-0"	1'-9"	10'-7 1/2"	0'-1 1/4"	0'-1"
15"	14'-4"	2'-1"	14'-0"	0'-1 3/4"	0'-1 1/4"
18"	16'-10"	2'-4"	16'-6"	0'-2"	0'-1 1/2"
21" OR 24"	21'-10"	2'-10"	21'-6 1/2"	0'-2 1/2"	0'-2"

1. CONCRETE TO BE 4000 PSI MINIMUM COMPRESSIVE STRENGTH. IF PIPE IS TO BE SKEWED, THE OPENING WILL BE ADJUSTED TO ACCOMMODATE. REINFORCING STEEL IN ACCORDANCE WITH ASTM A615 (REINFORCING BARS).
2. PIPE DIMENSIONS SHOWN ARE MINIMUM. ACTUAL DIMENSIONS MAY VARY WITH MANUFACTURER.
3. BOTTOM OF STRUCTURE TO BE ON THE SAME GRADE AS DRAINAGE DITCH.
4. FOR DETAILS OF GRATE AND NUMBER OF GRATES REQUIRED SEE EW-11A.
5. 3/4" CHAMFER MAY BE PROVIDED ON ALL EDGES AT MANUFACTURER'S OPTION.
6. HEADWALL TO BE BEVELED IN ALL AREAS EXCEPT WHERE A CONFLICT WITH INVERT OR WINGWALLS OCCUR.
7. BEVEL EDGE IS REQUIRED ON THE HEADWALL AT THE INLET END OF THE CULVERT (WHERE THE FLOW ENTERS THE CULVERT).
8. HEADWALL AT THE OUTLET END OF THE CULVERT MAY BE EITHER SQUARE EDGE OR BEVEL EDGE.
9. PIPE OPENINGS IN PRECAST DRAINAGE UNITS SHALL NOT EXCEED 4 INCHES AT ANY GIVEN POINT BETWEEN THE PIPE AND THE PRECAST UNIT.

SPECIFICATION REFERENCE
105
233
302

PRECAST PIPE ENDWALL WITH LOAD-CARRYING GRATE

12" - 24" CIRCULAR PIPES

VIRGINIA DEPARTMENT OF TRANSPORTATION

VDOT	
ROAD AND BRIDGE STANDARDS	
REVISION DATE	SHEET 1 OF 1
101.31	

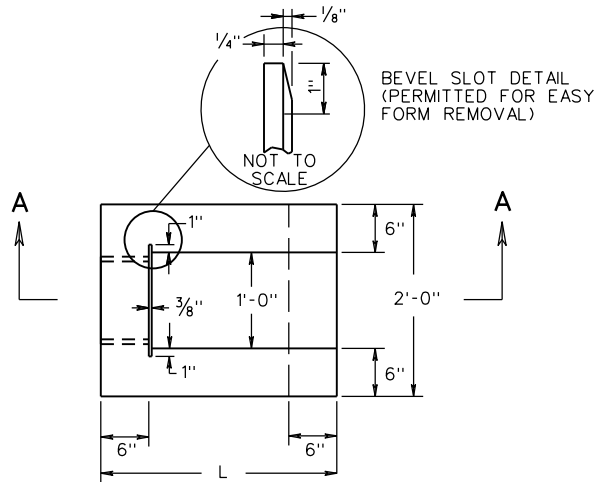

PLAN

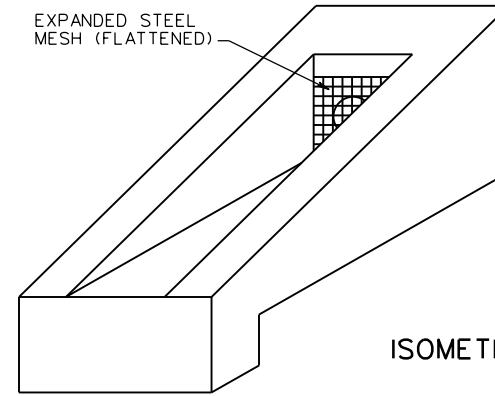

ISOMETRIC

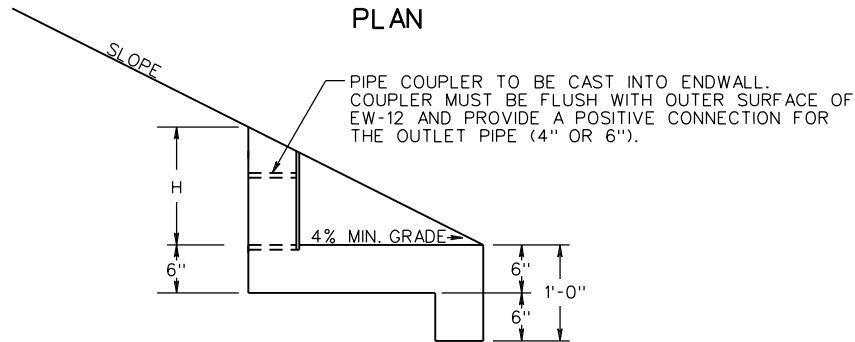

SECTION A-A

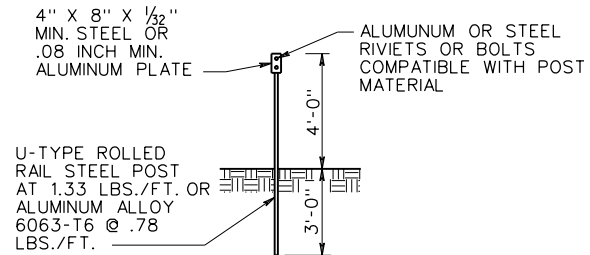

UNDERDRAIN OUTLET MARKER DETAIL

NOTES:

1. TYPICAL ENDWALL TO BE PLACED AT THE ENDS OF ALL UNDERDRAIN OUTLETS, BARRING LOCATIONS WHERE UNDERDRAIN IS TIED INTO OTHER DRAINAGE STRUCTURES. ENDWALL TO BE INSTALLED PERPENDICULAR TO ROADWAY AND FLUSH WITH THE SLOPE.
2. OUTLET PIPES SHALL BE RIGID NONPERFORATED, SMOOTH-BORE PIPE, MEETING THE REQUIREMENTS OF 70 PSITESTED ACCORDING TO ASTM 2412.
3. EXPANDED STEEL MESH (FLATTENED) SHALL HAVE OPENINGS OF APPROX. 1/2" X 1" AND WEIGH APPROX. 0.82 LBS. PER SQ. FT. MESH SHALL BE GALVANIZED IN ACCORDANCE WITH ASTM A-123. THE MESH SHALL EXTEND A MINIMUM OF 1" ABOVE THE O.D. OF THE PIPE, AND IS A BARRIER FOR RODENTS, ETC. THE SLOT FOR THE STEEL MESH IS TO BE CONSTRUCTED SO THAT THE MESH CAN BE REMOVED FOR CLEANOUT PURPOSES.
4. THIS ITEM MAY BE PRECAST OR CAST IN PLACE.
5. STEEL POSTS AND PLATES TO BE PAINTED OR GALVANIZED IN ACCORDANCE WITH THE ROAD AND BRIDGE SPECIFICATIONS. IF PAINTED THE FINAL COAT SHALL BE NO. 13 ALUMINUM PAINT OR NO. 11 WHITE PAINT.
6. MARKER TO BE PLACED AT ALL EW-12 UNDERDRAIN INSTALLATIONS.
7. MARKER WILL BE PAID FOR IN ACCORDANCE WITH SECTION 501 OF THE ROAD AND BRIDGE SPECIFICATIONS.

PIPE I.D.	SLOPE	DIMENSIONS		CLASS A3 CONCRETE CUBIC YARDS
		L	H	
4"	2:1	2'-5 1/2"	1'-2 3/4"	0.19
4"	3:1	3'-5 1/4"	1'-1 3/4"	0.25
4"	4:1	4'-5"	1'-1 1/4"	0.30
6"	2:1	2'-10 1/2"	1'-5 1/4"	0.20
6"	3:1	4'-3 1/4"	1'-4 1/4"	0.30
6"	4:1	5'-3"	1'-3 3/4"	0.38



ROAD AND BRIDGE STANDARDS

SHEET 1 OF 1

REVISION DATE

101.32

01/15

A COPY OF THE ORIGINAL SEALED AND SIGNED DRAWING IS ON FILE IN THE CENTRAL OFFICE.
STANDARD ENDWALL FOR PIPE UNDERDRAIN

VIRGINIA DEPARTMENT OF TRANSPORTATION

SPECIFICATION REFERENCE

105
233
302
501

END-SECTION 12" - 60" PIPE

HUB END ON OUTLET END-SECTIONS
SPIGOT END ON INLET END-SECTION

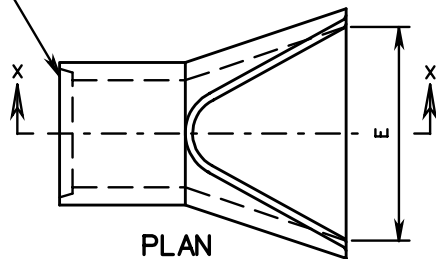

PLAN

CONCRETE TO BE
4000 PSI MINIMUM

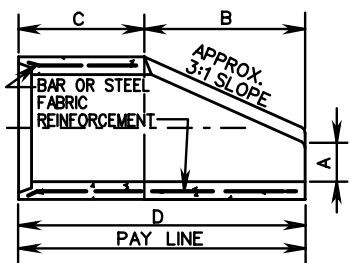

SECTION X-X

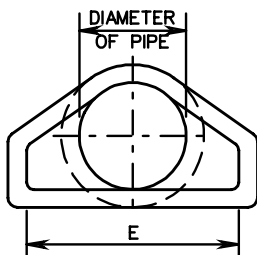

END VIEW

END SECTION DIMENSIONS

PIPE DIAMETER	A	B	C	D	E
12"	4"	2'-0"	2'-0"	4'-0"	2'-0"
15"	6"	2'-3"	1'-9"	4'-0"	2'-6"
18"	9"	2'-3"	1'-9"	4'-0"	3'-0"
21"	9 1/4"	2'-11"	2'-1"	5'-0"	3'-6"
24"	9 1/2"	3'-7"	2'-6"	6'-1"	4'-0"
27"	10 3/4"	4'-0"	2'-1"	6'-1"	4'-6"
30"	1'-0"	4'-6"	1'-7 3/4"	6'-1 3/4"	5'-0"
33"	1'-1 1/2"	4'-10 1/2"	2'-3 1/4"	7'-1 3/4"	5'-6"
36"	1'-3"	5'-3"	2'-10 3/4"	8'-1 3/4"	6'-0"
42"	1'-9"	5'-3"	2'-11"	8'-2"	6'-6"
48"	2'-0"	6'-0"	2'-2"	8'-2"	7'-0"
54"	2'-3"	5'-5"	2'-9 1/4"	8'-2 1/4"	7'-6"
60"	2'-11"	5'-0"	3'-3"	8'-3"	8'-0"

ALTERNATE END-SECTION 12" - 60" PIPE

ES-1

HUB END ON OUTLET END-SECTIONS
SPIGOT END ON INLET END-SECTION

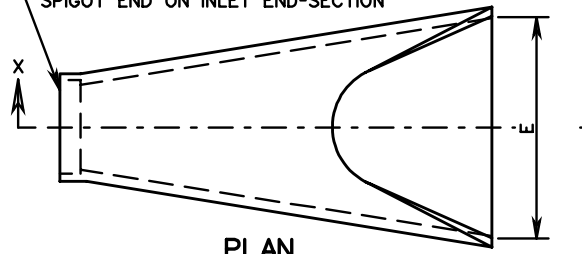

PLAN

CONCRETE TO BE
4000 PSI MINIMUM

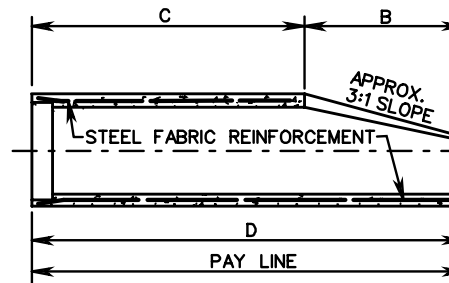

SECTION X-X

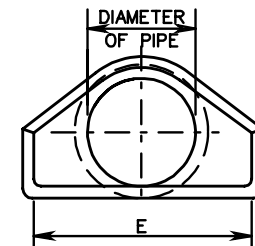

END VIEW

END SECTION DIMENSIONS

PIPE DIAMETER	A	B	C	D	E
12"	4"	2'-0"	4'-1"	6'-1"	2'-0"
15"	6"	2'-3"	3'-10"	6'-1"	2'-6"
18"	9"	2'-3"	3'-10"	6'-1"	3'-0"
21"	9"	2'-11"	3'-2"	6'-1"	3'-6"
24"	10"	3'-7"	2'-8"	6'-3"	4'-0"
27"	10 1/2"	4'-0"	2'-1 1/2"	6'-1 1/2"	4'-6"
30"	1'-0"	4'-6"	1'-7 3/4"	6'-1 3/4"	5'-0"
33"	1'-1 1/2"	4'-10 1/2"	2'-3 1/4"	8'-1 3/4"	5'-6"
36"	1'-3"	5'-3"	2'-10 3/4"	8'-1 3/4"	6'-0"
42"	1'-9"	5'-3"	2'-11"	8'-2"	6'-6"
48"	2'-0"	6'-0"	2'-2"	8'-2"	7'-0"
54"	2'-3"	5'-5"	2'-11"	8'-4"	7'-6"
60"	2'-6"	5'-0"	3'-3"	8'-3"	8'-0"

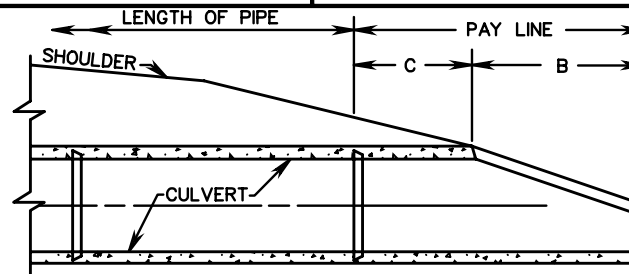

SLOPE DETAIL

NOTES:

PIPE LENGTHS SHOWN ON PLANS ARE BASED ON END-SECTION DESIGN SHOWN ON THE LEFT. IF THE CONTRACTOR ELECTS TO USE THE ALTERNATE DESIGN SHOWN ON THE RIGHT, LENGTHS WILL BE REDUCED BY THE DIFFERENCE IN DIMENSION "D".

SPECIFICATION REFERENCE

302

FLARED END SECTION
12" - 60" CONCRETE PIPE CULVERTS

VIRGINIA DEPARTMENT OF TRANSPORTATION

VDOT

ROAD AND BRIDGE STANDARDS

REVISION DATE

SHEET 1 OF 1

102.01

CONCRETE TO BE
4000 PSI MINIMUM

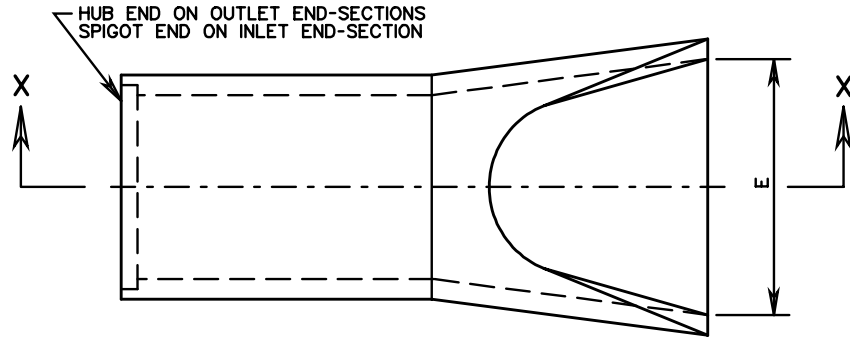

END SECTION DIMENSIONS

SPAN X RISE	A	B	C	L	E
23" X 14"	6"	2'-3"	3'-10"	6'-1"	2'-8"
30" X 19"	9"	2'-11"	3'-2"	6'-1"	3'-6"
38" X 24"	10"	3'-8"	2'-6"	6'-2"	4'-0"
42" X 27"	12"	4'-6"	1'-8"	6'-2"	5'-0"
45" X 29"	13"	4'-11"	3'-3"	8'-2"	5'-6"
53" X 34"	15"	5'-3"	2'-11"	8'-2"	6'-0"

PLAN

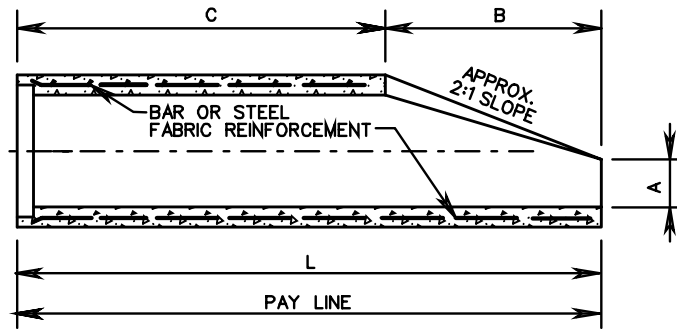

SECTION X-X

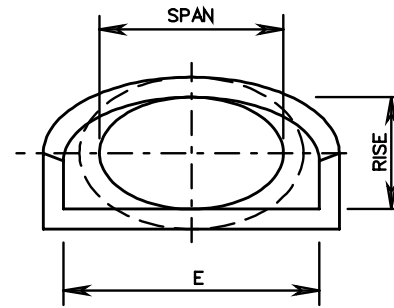

END VIEW

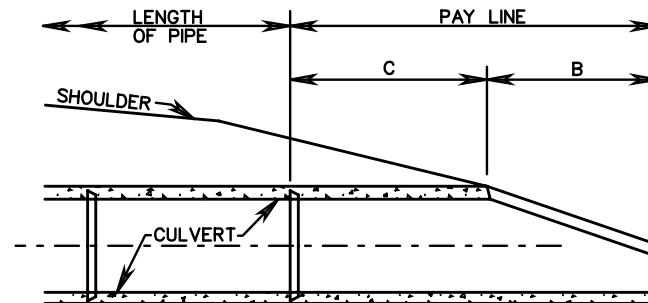

SLOPE DETAIL



ROAD AND BRIDGE STANDARDS

SHEET 1 OF 1

REVISION DATE

102.02

FLARED END-SECTION

23" x 14" TO 53" x 34" ELLIPTICAL CONCRETE PIPE CULVERTS

VIRGINIA DEPARTMENT OF TRANSPORTATION

SPECIFICATION
REFERENCE

302

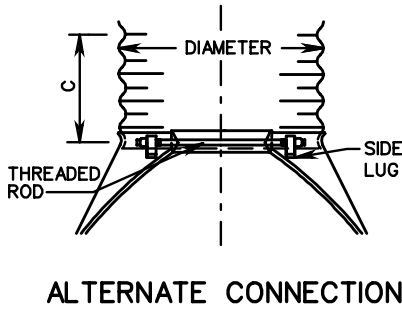
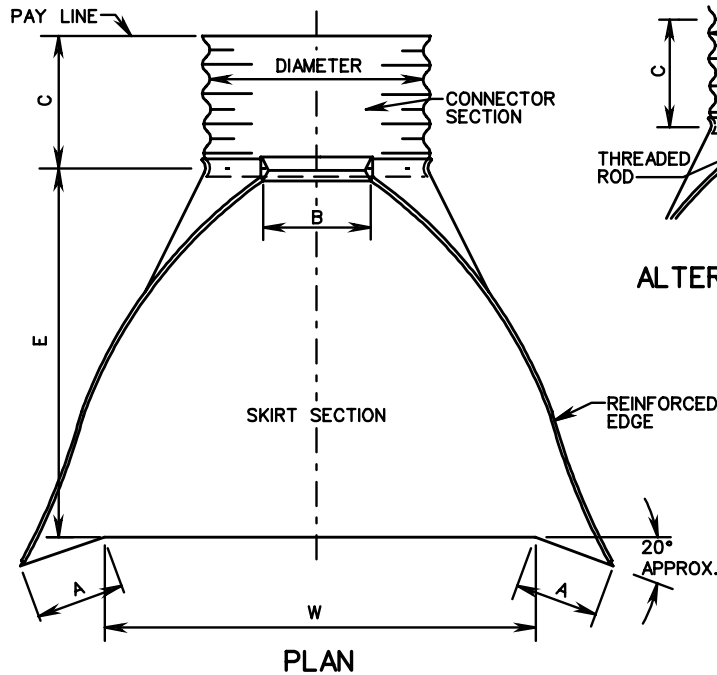

ALTERNATE CONNECTION

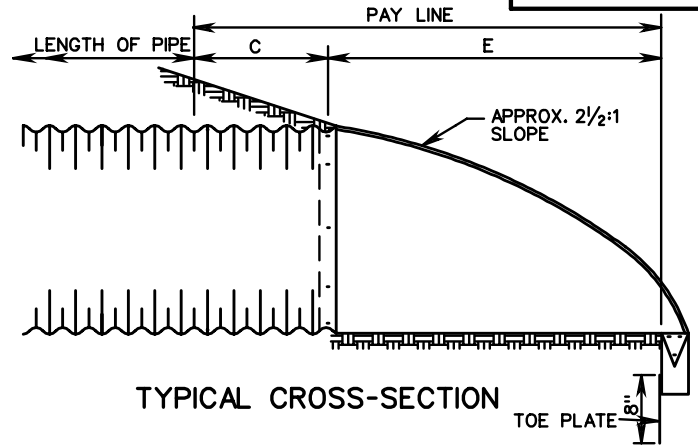

TYPICAL CROSS-SECTION

PIPE DIAMETER	SHEET THICKNESS		DIMENSIONS					
	STEEL	ALUMINUM	A 1" TOL.	B MAX.	H 1" TOL.	E 1/2" TOL.	W 2" TOL.	C
12"	.064"	.060"	6"	6"	6"	21"	24"	24"
15"	.064"	.060"	7"	8"	6"	26"	30"	24"
18"	.064"	.060"	8"	10"	6"	31"	36"	24"
21"	.064"	.060"	10"	12"	6"	36"	42"	24"
24"	.064"	.060"	10"	13"	6"	41"	48"	24"
27"/30"	.064"	.075"	12"	16"	8"	51"	60"	24"
36"	.064"	.075"	14"	19"	9"	60"	72"	36"
42"	.064"	.105"	16"	22"	11"	69"	84"	36"
48"	.064"	.105"	18"	27"	12"	78"	90"	24"
54"	.064"/.079"	.105"	18"	30"	12"	84"	102"	36"
60"	.064"/.079"	.105"/.135"	18"	33"	12"	87"	114"	36"

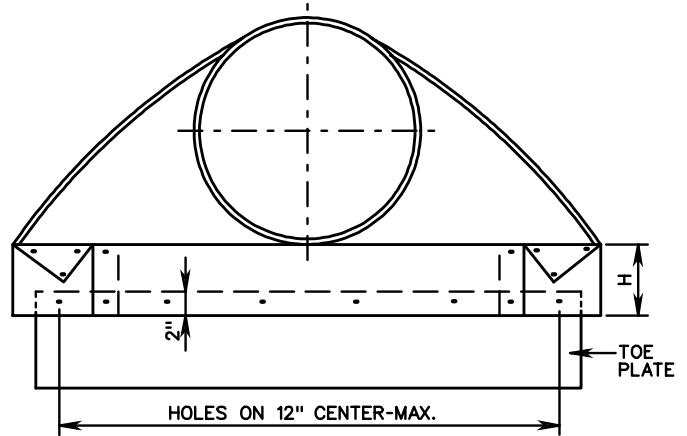

ELEVATION

NOTES:

1. TOE PLATE TO BE PUNCHED TO MATCH HOLES IN SKIRT LIP. 3/8" GALVANIZED BOLTS TO BE FURNISHED. LENGTH OF TOE PLATE IS W + 10" FOR 12" TO 30" DIAMETER PIPE AND W + 22" FOR 36" TO 60" DIAMETER PIPE.
2. SKIRT SECTION 12" TO 30" DIAMETER PIPE TO BE MADE IN ONE PIECE.
3. SKIRT SECTION FOR 36" TO 54" DIAMETER PIPE MAY BE MADE FROM TWO SHEETS JOINED BY RIVETING OR BOLTING ON CENTER LINE, 60" MAY BE CONSTRUCTED IN 3 PIECES.
4. CONNECTOR SECTION, CORNER PLATE AND TOE PLATE TO BE SAME SHEET THICKNESS AS SKIRT.
5. END-SECTION AND FITTINGS ARE TO BE STEEL FOR USE WITH STEEL PIPE.
6. END-SECTION AND FITTINGS ARE TO BE ALUMINUM ALLOY FOR USE WITH ALUMINUM ALLOY PIPE.
7. EITHER THE STEEL OR ALLUMINUM END-SECTION DETAILED MAY BE USED FOR PLASTIC PIPE SIZES SHOWN IN ST'D. PC-1 OR AN APPROVED PLASTIC END-SECTION MAY BE USED.
8. WHERE FLARED END-SECTION ARE TO BE USED WITH ASPHALT COATED AND PAVED METAL PIPE, END SECTIONS DO NOT NEED TO BE COATED OR PAVED.

SPECIFICATION REFERENCE	302	<h2 style="text-align: center;">FLARED END SECTION</h2> <h3 style="text-align: center;">12" - 60" CORRUGATED PIPE CULVERTS</h3> <p style="text-align: center;">VIRGINIA DEPARTMENT OF TRANSPORTATION</p>	<p>ROAD AND BRIDGE STANDARDS</p>	
			REVISION DATE	SHEET 1 OF 1
		102.03		

ALTERNATE CONNECTION

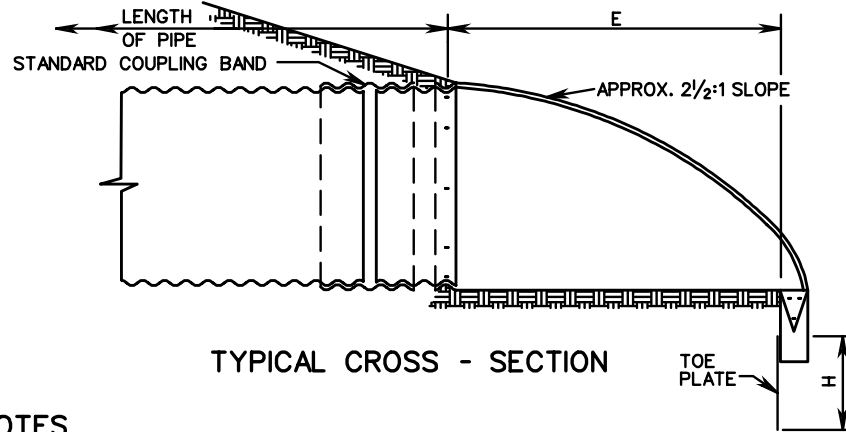
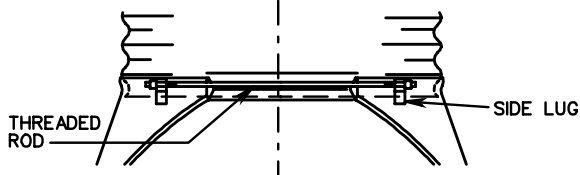

TYPICAL CROSS - SECTION

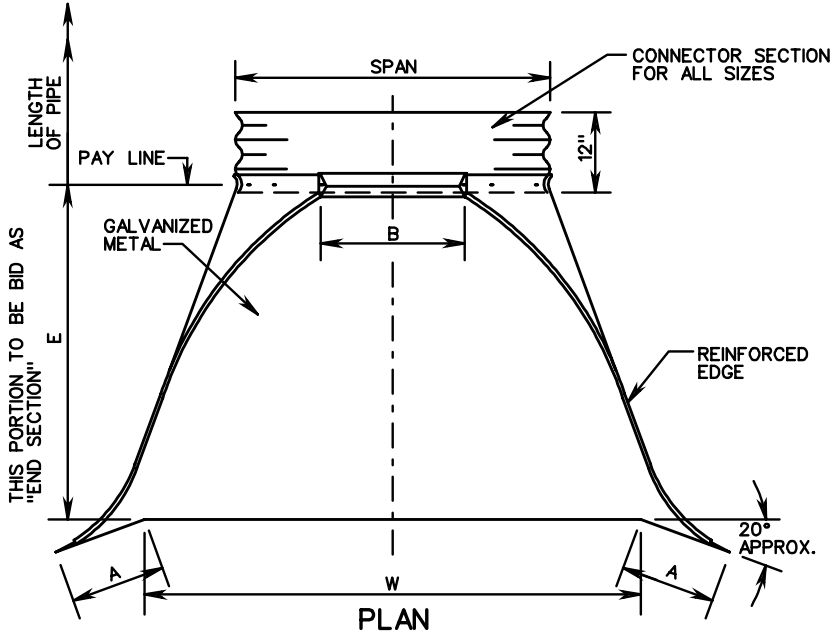

PLAN

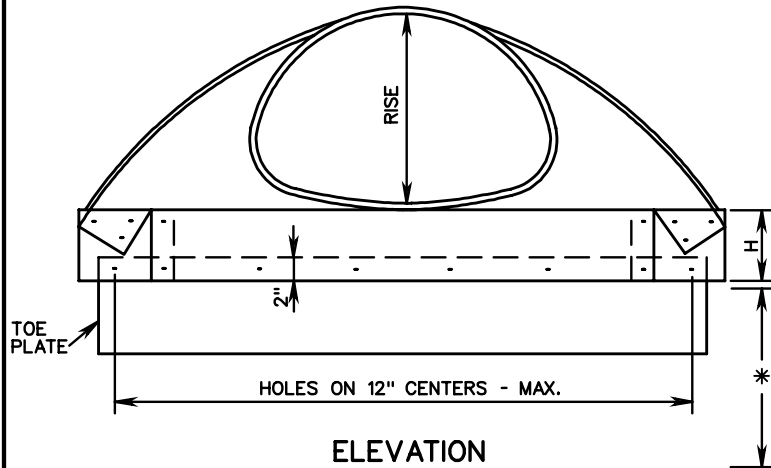

ELEVATION

NOTES

1. TOE PLATE TO BE PUNCHED TO MATCH HOLES IN SKIRT LIP.
2. 3/8" GALVANIZED BOLTS TO BE FURNISHED, LENGTH OF TOE PLATE IS W + 10" WITH RISE OF 13" TO 29" INCLUDED AND W + 18" MIN. WITH RISE OF 33" TO 47" INCLUDED.
3. SKIRT SECTION WITH RISE OF 13" TO 24" INCLUDED TO BE MADE IN ONE PIECE.
4. SKIRT SECTION WITH RISE OF 29" TO 38" INCLUDED MAY BE MADE FROM TWO SHEETS JOINED BY RIVETING OR BOLTING ON CENTER LINE.
5. SKIRT SECTION WITH RISE OF 43" TO 47" INCLUDED MAY BE MADE FROM THREE SHEETS JOINED BY RIVETING OR BOLTING AT EQUAL DISTANCES FROM CENTER LINE.
6. CONNECTOR SECTION, CORNER PLATE AND TOE PLATE TO BE SAME SHEET THICKNESS AS SKIRT AND SAME TYPE OF MATERIAL AS CULVERT.
7. WHERE FLARED END - SECTIONS ARE TO BE USED WITH ASPHALT COATED AND PAVED METAL PIPE, END SECTIONS DO NOT NEED TO BE COATED OR PAVED.
8. * INDICATES PIPE ARCHES FOR WHICH DIMENSIONS FOR EITHER CORRUGATION MAY BE USED WITHIN FILL HEIGHT LIMITATIONS.

PIPE-ARCH DIMENSIONS											
3" x 1" and 5" x 1" CORRUGATIONS			2 2/3" x 1/2" CORRUGATIONS				DIMENSIONS				
SPAN	RISE	SHEET THICKNESS	SPAN	RISE	SHEET THICKNESS		1" TOL.	MAX.	1" TOL.	1/2" TOL.	2" TOL.
					STEEL	ALUM.					
			17"	13"	.064"	.060	4 1/2"	9"	6"	19"	30"
			21"	15"	.064"	.060	5 1/4"	10"	6"	23"	36"
			24"	18"	.064"	.060	6 1/4"	11 1/2"	6"	28"	42"
			28"	20"	.064"	.060	7"	14"	6"	31 1/2"	48"
			35"	24"	.064"	.075	8 3/4"	16"	6"	38 1/2"	60"
40"	31"	.079"	42"	29"	.064"	.105	10 3/4"	17 1/2"	7 5/8"	47"	75"
46"	36"	.079"	49"	33"	.109"	.105	12 1/4"	20"	9 1/8"	54"	85"
53"	41"	.079"	57"	38"	.109"	.105	14"	22"	10 5/8"	63"	96"
60"	46"	.079"	64"	43"	.109"	.105	15 3/4"	23"	10 5/8"	70"	112"
66"	51"	.079"	71"	47"	.138"	.135	17 1/4"	24"	12 1/8"	77"	128"



ROAD AND BRIDGE STANDARDS

SHEET 1 OF 1

REVISION DATE

102.04

FLARED END-SECTION

13" - 47" RISE METAL PIPE ARCHES

VIRGINIA DEPARTMENT OF TRANSPORTATION

SPECIFICATION REFERENCE

302

THIS PAGE INTENTIONALLY LEFT BLANK

SPECIFICATION
REFERENCE

VIRGINIA DEPARTMENT OF TRANSPORTATION



ROAD AND BRIDGE STANDARDS

REVISION DATE

SHEET 1 OF 1

102.05

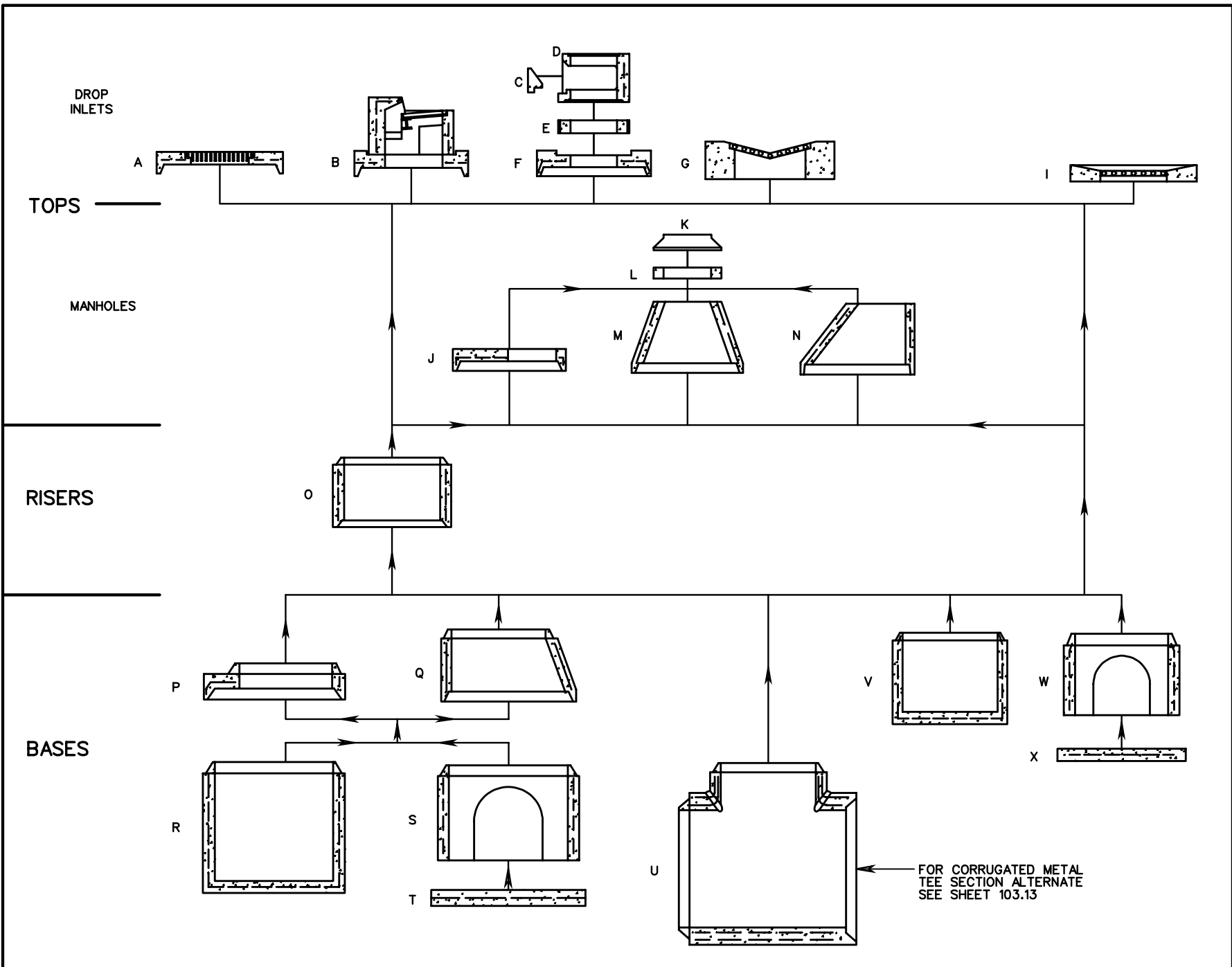

ROAD AND BRIDGE STANDARDS

PRECAST UNIT ASSEMBLY DIAGRAM

SPECIFICATION REFERENCE

SHEET 1 OF 1

REVISION DATE

VIRGINIA DEPARTMENT OF TRANSPORTATION

103.01

LEGEND

PAGE

A - FLAT SLAB TOP WITH FRAME AND GRATE (T-DI-1) _____ 103.03
 B - DROP INLET TOP UNIT (T-DI-2) _____ 103.04
 C - THROAT FACE BLOCK (T-DI-3,4) _____ 103.05, 103.06
 D - CURB DROP INLET THROAT SECTION (T-DI-3,4) _____ 103.05, 103.06
 E - SPACER UNIT (T-MH-2) _____ 103.09
 F - FLAT SLAB TOP WITH HOLE (T-MH-2) _____ 103.09
 G - DROP INLET TOP UNIT (T-DI-5) _____ 103.07
 I - DROP INLET TOP UNIT (T-DI-7) _____ 103.08
 J - FLAT SLAB TOP UNIT (T-MH-2) _____ 103.09
 K - MANHOLE FRAME AND COVER (T-MH-1) _____ 106.02 THRU 106.06
 L - SPACER UNIT (T-MH-2) _____ 103.09
 M - CONCENTRIC TAPER UNIT (T-MH-2) _____ 103.09
 N - ECCENTRIC TAPER UNIT (T-MH-2) _____ 103.09
 O - RISER UNIT (R-1) _____ 103.10
 P - FLAT SLAB REDUCER (R-2) _____ 103.10
 Q - TAPER REDUCER (R-3) _____ 103.10
 R - MONOLITHIC BASE UNIT - OVER 4' DIA. (B-1) _____ 103.11
 S - DOGHOUSE BASE UNIT - OVER 4' DIA. (B-2) _____ 103.11
 T - FOOTING (B-2) _____ 103.11
 U - TEE SECTION BASE UNIT (B-3) _____ 103.12
 V - MONOLITHIC BASE UNIT - OVER 4' DIA. (B-1) _____ 103.11
 W - DOGHOUSE BASE UNIT - OVER 4' DIA. (B-2) _____ 103.11
 X - FOOTING (B-2) _____ 103.11
 ALTERNATE JOINT DETAIL _____ 103.03

GENERAL NOTES - PRECAST

PRECAST STRUCTURES WILL CONFORM TO SECTION 302 OF THE SPECIFICATIONS. THE MANUFACTURER WILL HAVE THE OPTION OF SELECTING THE COMBINATION OF PRECAST UNITS TO COMPLETE A STRUCTURE UNLESS OTHERWISE NOTED ON THE PLANS.

THE "H" (LINEAR FEET FOR MANHOLES) DIMENSION SHOWN ON THE STANDARDS AND SPECIFIED ON THE PLANS WILL BE MEASURED FROM THE INVERT OF THE OUTFALL PIPE TO THE TOP OF THE MASONRY STRUCTURE. PLAN "H" DIMENSIONS ARE APPROXIMATE ONLY FOR ESTIMATING PURPOSES AND THE ACTUAL DIMENSIONS SHALL BE DETERMINED BY THE CONTRACTOR FROM FIELD CONDITIONS.

IN THE EVENT THE INVERT OF THE OUTFALL PIPE IS HIGHER THAN THE BOTTOM OF THE STRUCTURE, THE INVERT OF THE STRUCTURE SHALL BE SHAPED WITH CEMENT MORTAR TO PREVENT STANDING OR PONDING OF WATER IN THE STRUCTURE. THIS WILL APPLY TO ALL STRUCTURES MEETING THIS CONDITION AND IS NOT TO BE CONFUSED WITH STANDARD IS-1 THE COST FOR INVERT SHAPING SHALL BE INCLUDED IN THE PRICE BID FOR THE STRUCTURE.

WHEN SPECIFIED ON THE PLANS THE INVERT IS TO BE SHAPED IN ACCORDANCE WITH STANDARD IS-1. THE COST OF FURNISHING AND PLACING ALL MATERIALS INCIDENTAL TO THE SHAPING IS TO BE INCLUDED IN THE PRICE BID FOR THE STRUCTURE.

ALL PRECAST STRUCTURES TO BE CONSTRUCTED WITH 4000 PSI MINIMUM CONCRETE.

STEPS IN ACCORDANCE WITH STANDARD ST-1 ARE TO BE PROVIDED IN ALL MANHOLES AND IN ALL DROP INLETS WITH AN "H" DIMENSION OF 4'-0" OR GREATER.

3" DIAMETER WEEP HOLES WILL BE REQUIRED IN PRECAST STRUCTURE'S LOCATED ADJACENT TO THE PAVEMENT TO DRAIN THE SUBBASE. PLACEMENT OF WEEP HOLES IN THE PRECAST UNIT WILL BE DETERMINED BY THE PROXIMITY OF THE STRUCTURE TO THE SUBBASE. WEEP HOLES MAY ALSO BE REQUIRED IN OTHER STRUCTURES WHEN CALLED FOR ON THE PLANS OR DIRECTED BY THE ENGINEER.

WEEP HOLES WILL HAVE 12" X 12" PLASTIC HARDWARE CLOTH, 1/4" MESH OR GALVANIZED STEEL WIRE, MINIMUM WIRE DIAMETER 0.03", NUMBER 4 MESH HARDWARE CLOTH ANCHORED FIRMLY TO OUTSIDE OF STRUCTURE.

PRECAST UNITS LOCATED ADJACENT TO CAST-IN-PLACE CONCRETE ITEMS, SUCH AS FLUMES, DITCHES, GUTTERS, AND SIDEWALKS SHALL BE CONNECTED TO THE ADJACENT UNIT BY MEANS OF NO. 4 SMOOTH STEEL DOWELS SPACED ON APPROXIMATELY 12" CENTERS THROUGHOUT THE CONTACT LENGTH AND EXTENDING AT LEAST 4" INTO BOTH THE PRECAST UNIT TO RECEIVE THE DOWELS, THEY SHALL NOT EXCEED 5/8" DIAMETER.

THE STANDARD SAFETY SLAB (SL-1) IS TO BE USED ONLY WHEN SPECIFIED IN THE PLANS ON THE DRAINAGE SUMMARY SHEET AND/OR THE DRAINAGE DESCRIPTION. REFER TO STANDARD SL-1 FOR SAFETY SLAB INFORMATION.

3/4" CHAMFER MAY BE PROVIDED ON ALL EDGES AT MANUFACTURER'S OPTION.

SPECIFICATION REFERENCE

GENERAL NOTES - PRECAST

VIRGINIA DEPARTMENT OF TRANSPORTATION



ROAD AND BRIDGE STANDARDS

REVISION DATE

SHEET 1 OF 1

07/12

103.02

T-DI-1

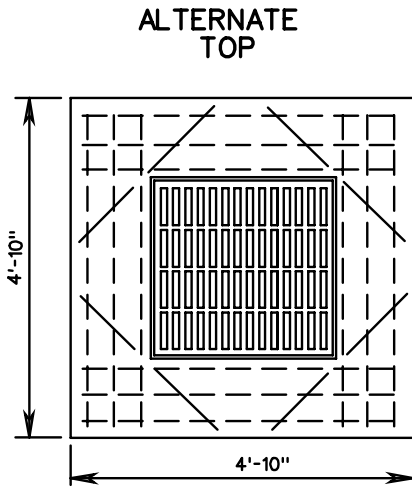
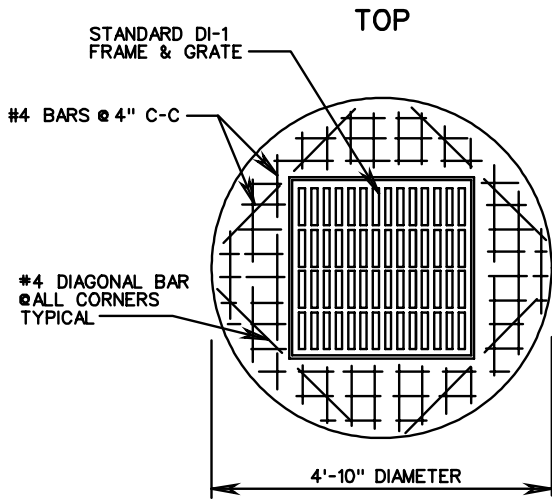

PIPE SIZE	H DIMENSION	
	CONCRETE	CORR. METAL
12"	2'-6"	2'-5"
15"	2'-9 ¹ / ₄ "	2'-8"
18"	3'-0 ¹ / ₂ "	2'-11"
21"	3'-3 ³ / ₄ "	3'-2"
24"	3'-7"	3'-5"

DI-1, 1A PC

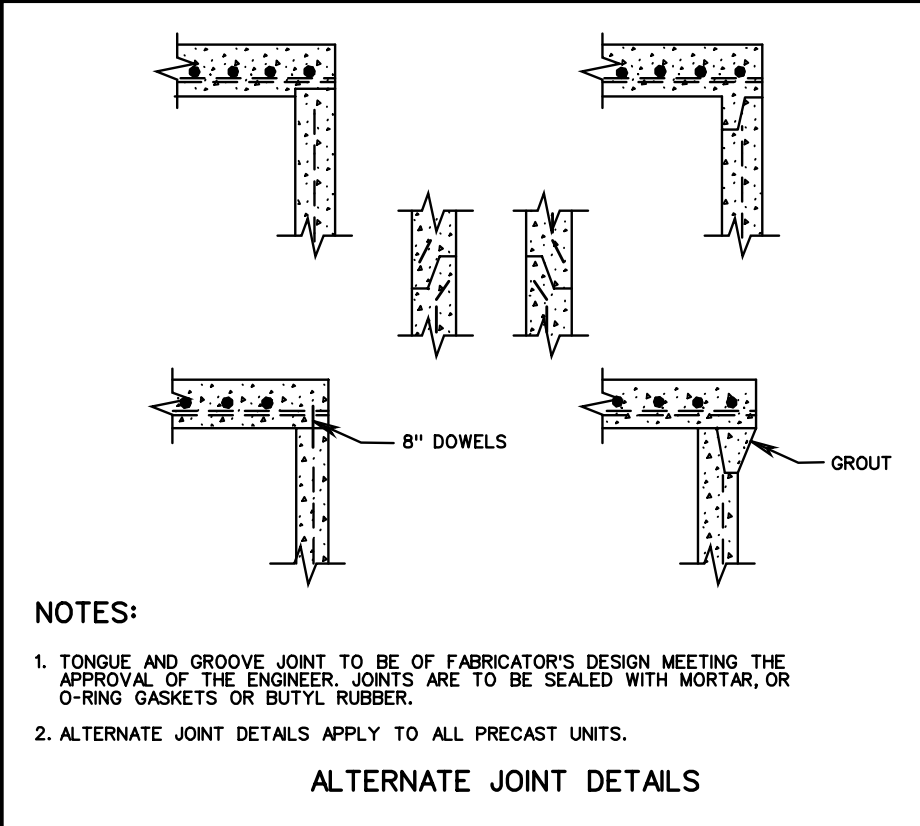
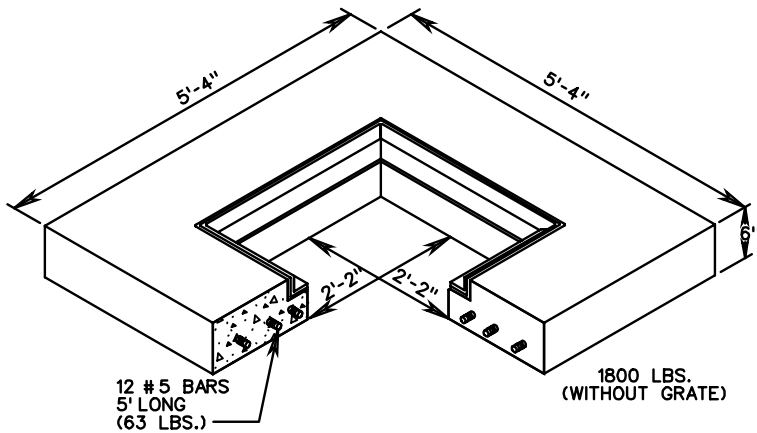

NOTES:

1. SEE GENERAL NOTES PRECAST FOR ADDITIONAL DETAILS.
2. CONCRETE TO BE 4000 PSIMINIMUM.
3. REINFORCING STEEL IN ACCORDANCE WITH ASTM C-478, ASTM A-497 (WIRE FABRIC) AND ASTM A-615 (REINFORCING BARS).
4. CONCRETE COVER AND GRATE ARE TO BE FURNISHED AS A SINGLE UNIT.
5. SEE STANDARD DI-1, 1A FOR DETAILS OF FRAME AND GRATE.
6. DIMENSIONS SHOWN ARE MINIMUM. ACTUAL DIMENSIONS MAY VARY WITH MANUFACTURER.

NOTES:

1. TONGUE AND GROOVE JOINT TO BE OF FABRICATOR'S DESIGN MEETING THE APPROVAL OF THE ENGINEER. JOINTS ARE TO BE SEALED WITH MORTAR, OR O-RING GASKETS OR BUTYL RUBBER.
2. ALTERNATE JOINT DETAILS APPLY TO ALL PRECAST UNITS.

ALTERNATE JOINT DETAILS



ROAD AND BRIDGE STANDARDS

STANDARD PRECAST TOP UNITS

SPECIFICATION REFERENCE

SHEET 1 OF 1

REVISION DATE

VIRGINIA DEPARTMENT OF TRANSPORTATION

103.03

105
233
302

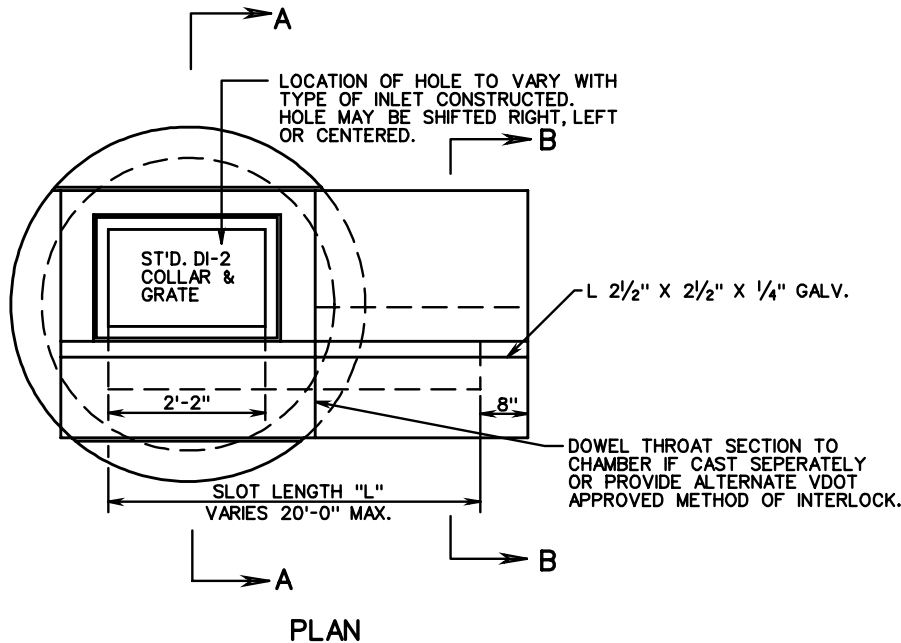

RECOMMENDED MINIMUM HEIGHT CHART	
PIPE SIZE	"H" DIMENSION (CONCRETE PIPE)
12"	4'-8"
15"	4'-11 1/4"
18"	5'-2 1/2"
21"	5'-5 3/4"
24"	5'-9"
27"	6'-0 1/4"
30"	6'-6 1/2"
33"	6'-9 3/4"
36"	7'-1"
42"	7'-7 1/2"
48"	8'-2"

NOTES

1. SEE GENERAL NOTES - PRECAST FOR ADDITIONAL DETAILS.
2. CONCRETE TO BE 4000 PSIMUMUM.
3. REINFORCING STEEL IN ACCORDANCE WITH ASTM-615.
4. DIMENSIONS SHOWN ARE MINIMUM. ACTUAL DIMENSIONS MAY VARY WITH MANUFACTURER.
5. FOR DETAILS OF FRAME AND GRATE SEE STANDARD DI-2A, B, C.
- * 6. VERTICAL REINFORCING BARS TO BE CONTINUOUS THROUGH JOINT.
7. STANDARD ST-1 STEPS NOT REQUIRED IN THIS TOP UNIT.

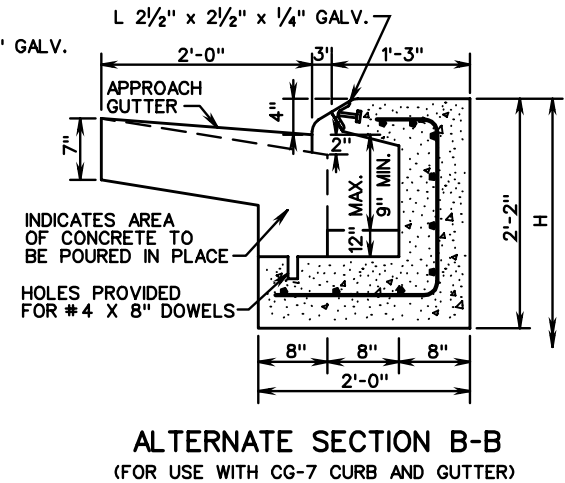
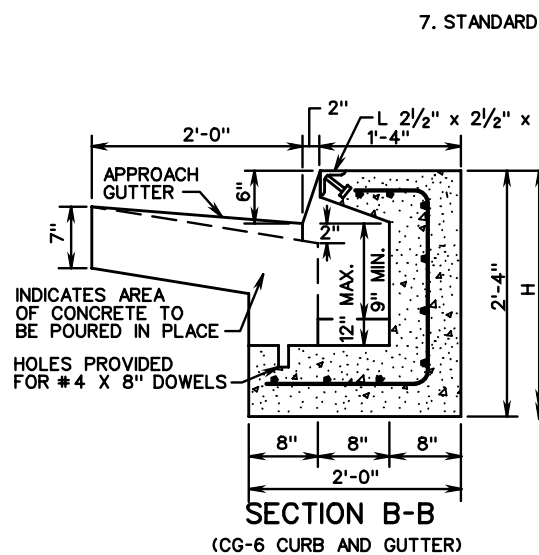
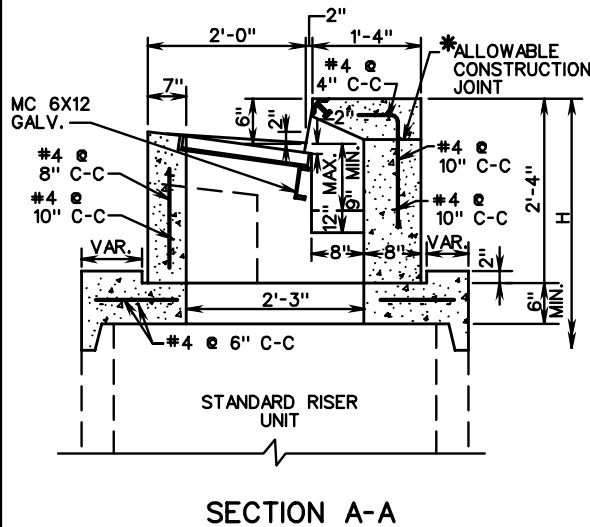

SPECIFICATION REFERENCE
105
233
302

STANDARD PRECAST TOP UNITS

VIRGINIA DEPARTMENT OF TRANSPORTATION

VDOT ROAD AND BRIDGE STANDARDS	
REVISION DATE	SHEET 1 OF 1
103.04	

CURB DROP INLET THROAT SECTION

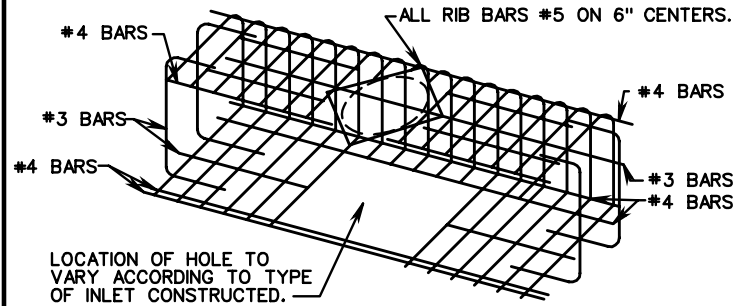
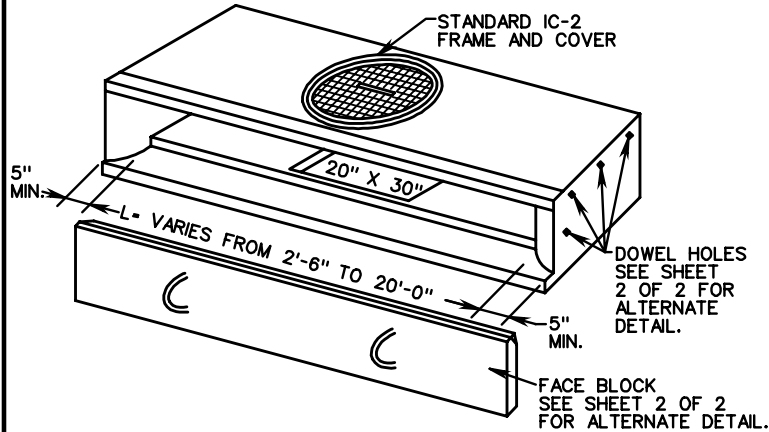

TYPICAL MINIMUM BAR REINFORCEMENT

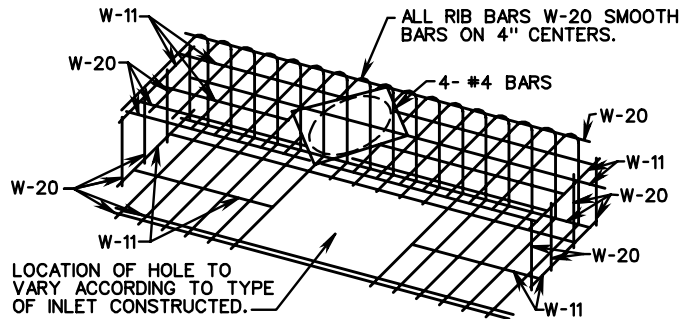

TYPICAL MINIMUM WELDED WIRE REINFORCEMENT

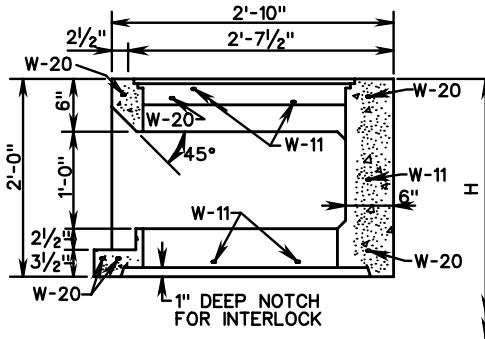
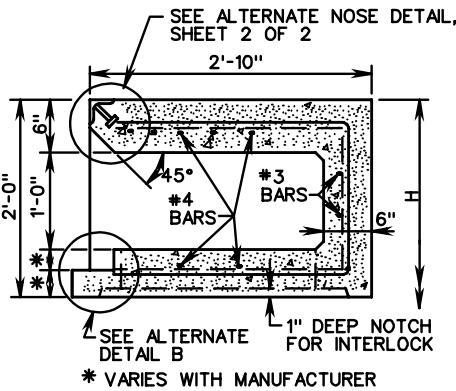

NOTES:

1. SEE GENERAL NOTES - PRECAST FOR ADDITIONAL DETAILS.
2. CONCRETE TO BE 4000 PSI MINIMUM COMPRESSIVE STRENGTH.
3. REINFORCING STEEL IN ACCORDANCE WITH ASTM A-615 FOR REINFORCING BARS.
4. REINFORCING IN ACCORDANCE WITH ASTM A-185 FOR WELDED WIRE MESH.
5. DIMENSIONS SHOWN ARE MINIMUM. ACTUAL DIMENSIONS MAY VARY WITH MANUFACTURER.
6. THIS UNIT MAY BE USED WITH ALL STANDARD DI-3 & DI-4 CURB DROP INLETS.
7. EACH FACE BLOCK SHALL HAVE 2 OR MORE LOOPS (#3 BARS) CAST IN FACE AS SHOWN. THESE LOOPS MAY BE USED FOR LIFT, AND FOR TIEING IN THE POURED IN PLACE GUTTER SECTION. FACE BLOCKS ARE TO BE SEALED WITH GROUT OR POLYSULFIDE SEALER.
8. STANDARD ST-1 STEPS NOT REQUIRED IN THIS TOP UNIT.

RECOMMENDED MINIMUM HEIGHT CHART

	PIPE SIZE	H DIMENSION CONCRETE PIPE
DI-3A,B,C, FOR 36" I.D. BASE UNIT	6"	2'-11"
	8"	3'-1 1/4"
	10"	3'-3 3/4"
	12"	3'-6"
	15"	3'-9 1/4"
	18"	4'-0 1/2"
DI-3A,B,C,D,E, & F FOR 48" I.D. BASE UNIT	21"	4'-3 3/4"
	6"	3'-9"
	8"	3'-11 1/4"
	10"	4'-1 1/4"
	12"	4'-4"
	15"	4'-7 1/4"
	18"	4'-10 1/2"
DI-3A,B,C,D,E, & F FOR 60" OR 72" I.D. BASE UNITS & DI-4A, B, C, D, E, & F	21"	5'-1 3/4"
	24"	5'-5"
	27"	5'-8 1/4"
	12"	4'-4"
	15"	4'-7 1/4"
	18"	4'-10 1/2"
	21"	5'-1 3/4"
	24"	5'-5"
	27"	5'-8 1/4"
	30"	6'-2 3/4"
	33"	6'-5 3/4"
36"	6'-9"	
42"	7'-3 1/2"	
48"	7'-10"	



ROAD AND BRIDGE STANDARDS

SHEET 1 OF 2

REVISION DATE

103.05

STANDARD PRECAST TOP UNITS

VIRGINIA DEPARTMENT OF TRANSPORTATION

SPECIFICATION REFERENCE

105
233
302

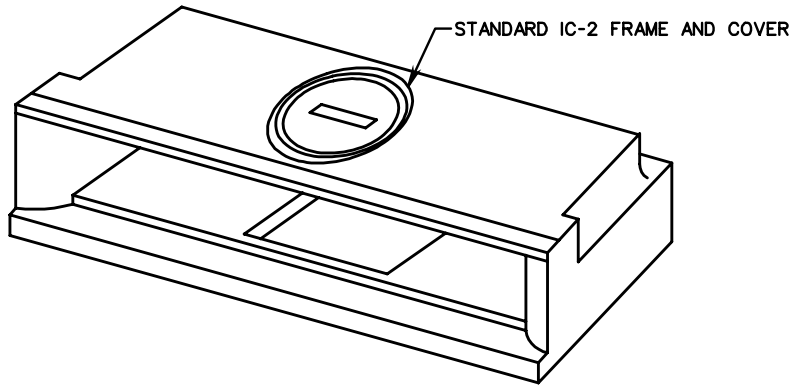

ISOMETRIC CURB DROP INLET THROAT SECTION ALTERNATE DESIGN

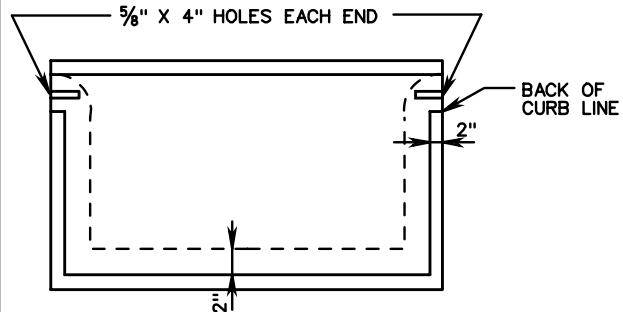

PLAN

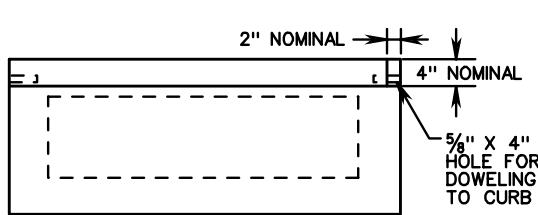

BACK VIEW

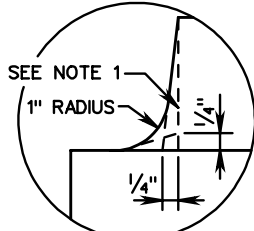

DETAIL A

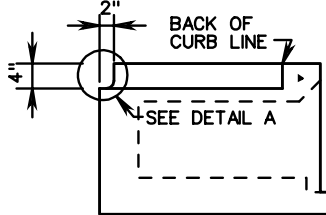

END VIEW

NOTES:

1. 2" x 4" NOTCH MAY BE FORMED WITH STRAIGHT SIDES, TAPERED SIDES OR TAPERED SIDES WITH RADIUS.
2. ALL DETAILS NOT SHOWN TO BE IN ACCORDANCE WITH SHEET 1 OF 2.

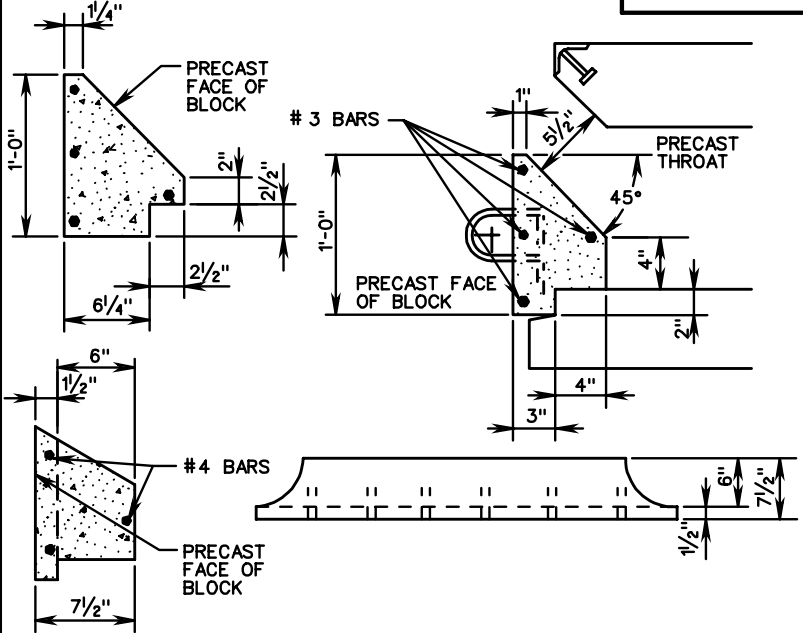

NOTE:

DOWEL HOLES PROVIDED TO PREVENT SETTLEMENT OF ADJACENT CONCRETE.

ALTERNATE DETAIL FOR FACE BLOCK (NOSE TYPE B)

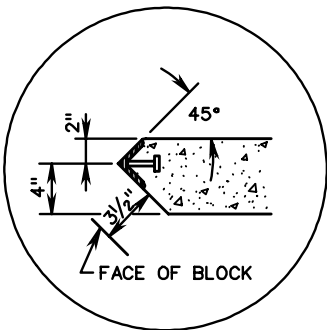

ALTERNATE NOSE DETAIL A

(FOR USE WITH MOUNTABLE CURB)

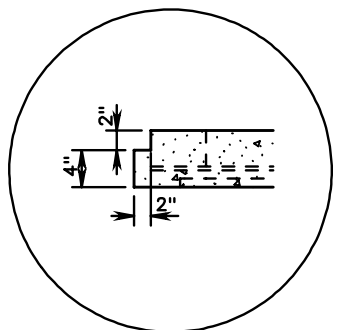

ALTERNATE DETAIL B

SPECIFICATION REFERENCE

- 105
- 233
- 302

STANDARD PRECAST TOP UNITS

VIRGINIA DEPARTMENT OF TRANSPORTATION



ROAD AND BRIDGE STANDARDS

REVISION DATE

SHEET 2 OF 2

103.06

T-DI-5

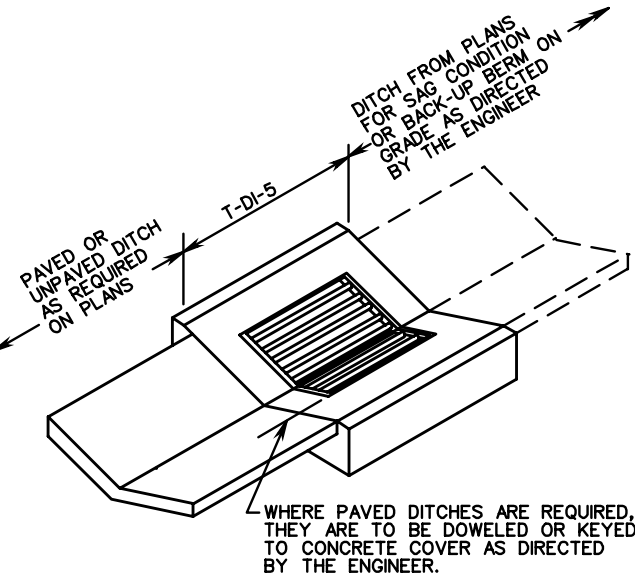
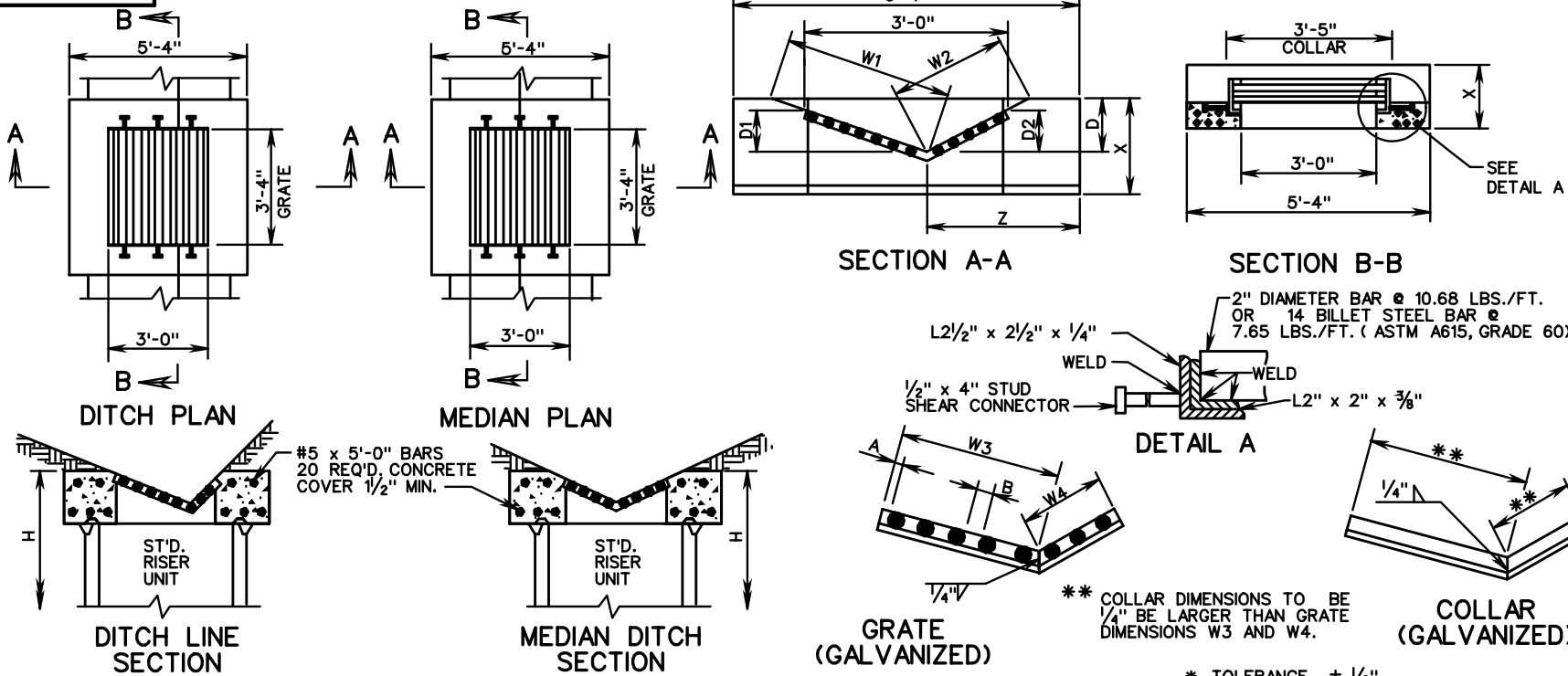

GRATE BAR SPACING CHART		
GRATE TYPE	MAXIMUM DIMENSION	
	a	b
A I	1 1/2"	3"
A III	1"	1"

ST'D PG-2 TYPE	COVER DIMENSIONS AND QUANTITIES								
	W1	W2	W3	W4	D*	D1	D2	X	Z
A1,A2,A3	3'-0 1/2"	2'-0 1/16"	2'-0 5/16"	1'-0 3/8"	6"	4"	3"	14"	2'-2"
B1,B2,B3,B4, C1,C2,C3	2'-9"	2'-9"	1'-6 7/16"	1'-6 7/16"	8"	4 1/2"	4 1/2"	16"	2'-8"
E	2'-3"	2'-3"	1'-8 1/16"	1'-8 1/16"	12"	9"	9"	19"	2'-8"

NOTES:

1. SEE GENERAL NOTES-PRECAST FOR ADDITIONAL DETAILS.
2. CONCRETE SHALL BE 4000 PSI MINIMUM.
3. REINFORCING STEEL SHALL BE IN ACCORDANCE WITH ASTM-A 615.
4. CONCRETE COVER AND GRATE ARE TO BE FURNISHED AS A SINGLE UNIT.
5. DIMENSIONS SHOWN ARE MINIMUM. ACTUAL DIMENSIONS MAY VARY WITH MANUFACTURER.
6. GRATE BARS ARE TO BE INSTALLED SO THEY WILL BE ALIGNED PARALLEL TO THE DITCH FLOW.
7. WHERE DITCH SLOPES DO NOT MATCH THOSE OF INLET COVER, THE AREA ADJACENT TO THE INLET IS TO BE GRADED TO PROVIDE A SMOOTH TRANSITION.
8. DI-5 IS TO BE UTILIZED IN LOCATIONS NOT NORMALLY SUBJECT TO TRAFFIC.

STANDARD PRECAST TOP UNITS

VIRGINIA DEPARTMENT OF TRANSPORTATION

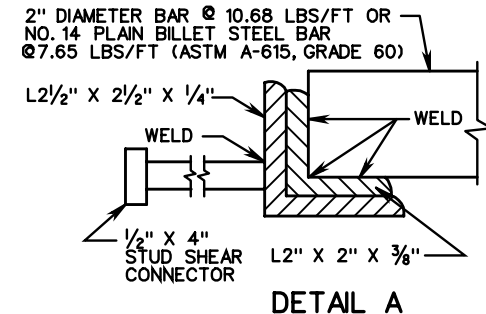
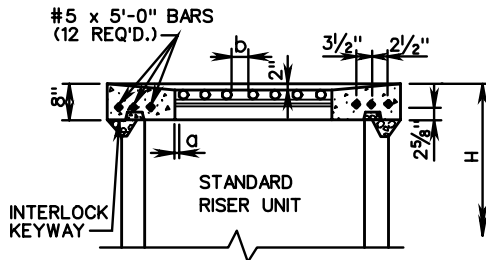
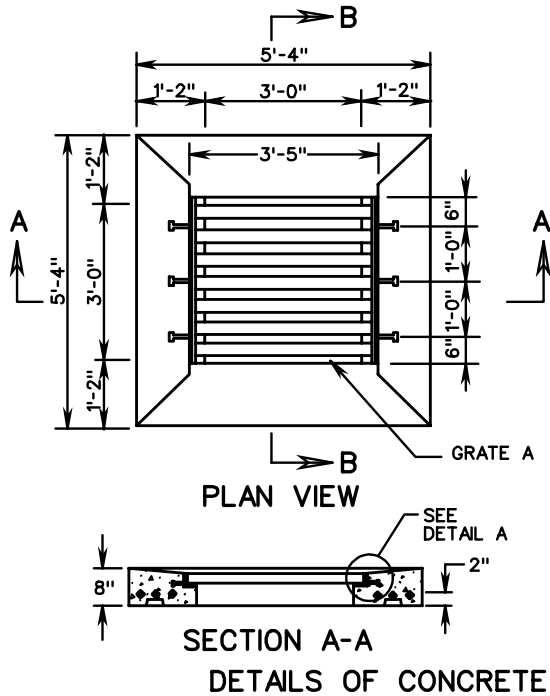

GRATE A BAR SPACING CHART		
GRATE TYPE	MAXIMUM DIMENSION	
	a	b
A I	1 1/2"	3"
A III	1"	1"

NOTES:

- SEE GENERAL NOTES-PRECAST FOR ADDITIONAL DETAILS.
- CONCRETE COVER AND GRATE ARE TO BE FURNISHED AS A SINGLE UNIT. OUTSIDE DIMENSIONS OF GRATE ARE TO BE 3'-4" X 2'-11 1/4" (GRATE A) OR 3'-4" X 2'-11 1/2" (GRATE B).
- DIMENSIONS SHOWN ARE MINIMUM. ACTUAL DIMENSIONS MAY VARY WITH MANUFACTURER.
- GRATE A IS TO BE UTILIZED IN LOCATIONS NOT NORMALLY SUBJECT TO TRAFFIC.
- GRATE B IS TO BE UTILIZED IN LOCATIONS NORMALLY SUBJECT TO TRAFFIC.
- ALTERNATE METHODS OF ANCHORING ANGLE IRON WILL BE ACCEPTABLE IF APPROVED BY THE ENGINEER.
- GRATE AND COLLAR ARE TO BE GALVANIZED AFTER FABRICATION.
- JOINTS BETWEEN CONCRETE COVER AND GUTTERS (WHEN REQUIRED) ARE TO BE DOWELED, KEYED, OR OTHER VDOT APPROVED METHODS.
- CONCRETE SHALL BE 4000 PSI MINIMUM.
- REINFORCING STEEL SHALL BE IN ACCORDANCE WITH ASTM A-615.
- GRATE BARS ARE TO BE INSTALLED SO THEY WILL BE ALIGNED PARALLEL TO THE DITCH FLOW.
- SEE STANDARD DI-7, 7A, 7B FOR DETAILS OF GUTTER, METHOD OF PLACEMENT, ALTERNATE METHODS OF CONSTRUCTION.

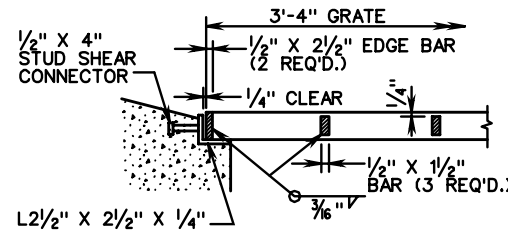
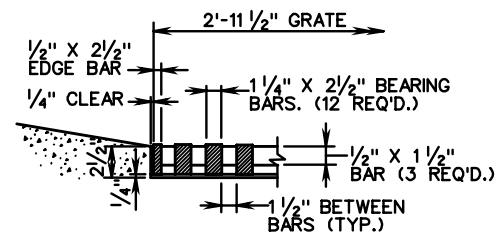
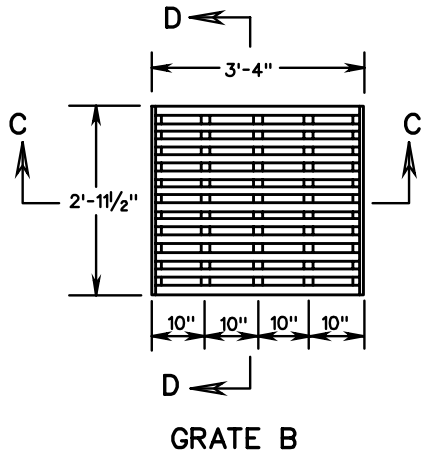

DETAILS OF LOAD CARRYING GRATE B

SPECIFICATION REFERENCE
105
233
302

STANDARD PRECAST TOP UNITS

VIRGINIA DEPARTMENT OF TRANSPORTATION

VDOT	
ROAD AND BRIDGE STANDARDS	
REVISION DATE	SHEET 1 OF 1
103.08	

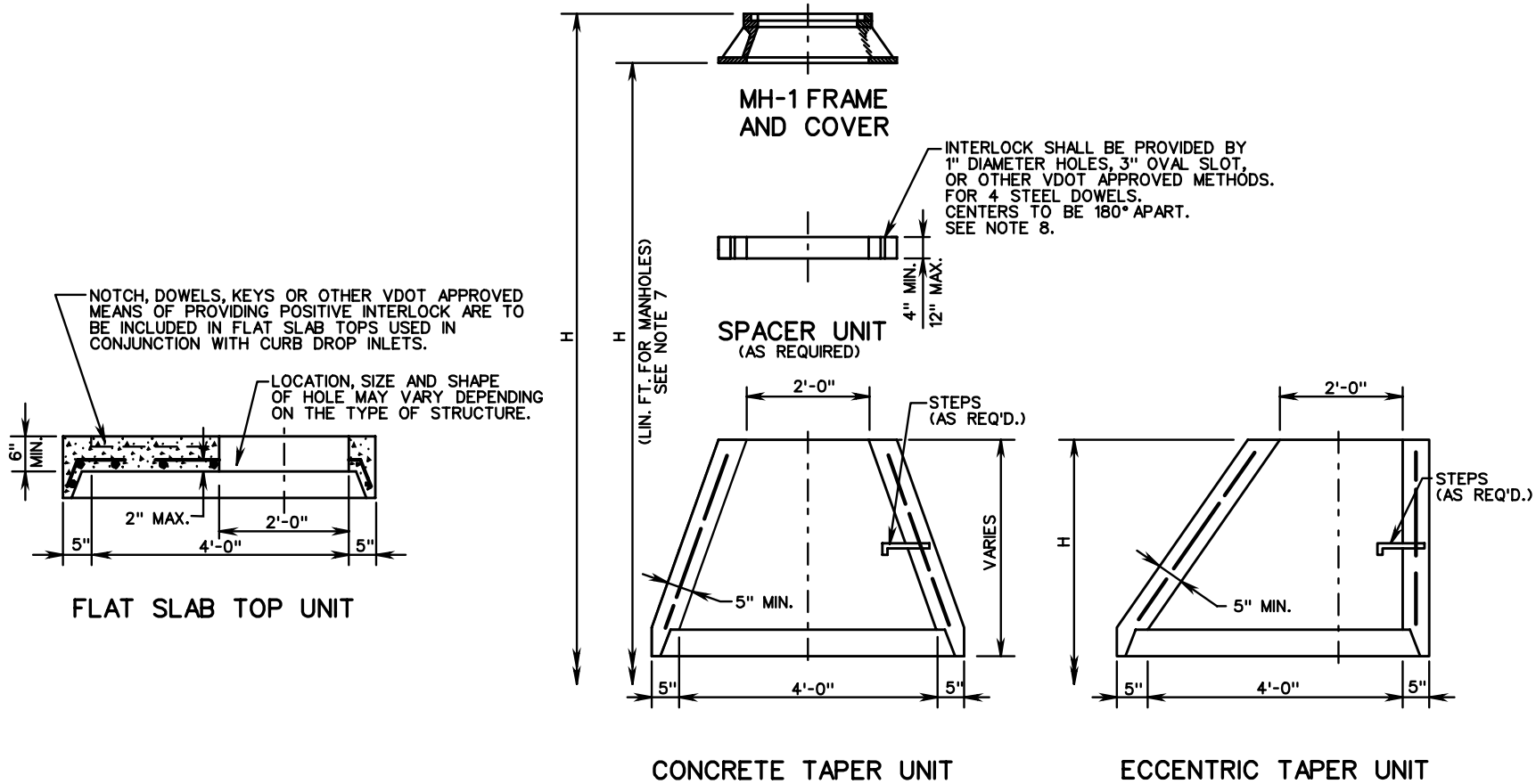

NOTES:

1. SEE GENERAL NOTES FOR ADDITIONAL INFORMATION ON WEEP HOLES, STEP REQUIREMENTS, "H" (LIN. FT. FOR MANHOLES) DIMENSION, ETC.
2. ALL SPACER UNITS, FLAT SLAB TOPS, AND TAPER UNITS ARE TO BE IN ACCORDANCE WITH THE REQUIREMENTS OF AASHTO M199.
3. CONCRETE SHALL BE 4000 PSI.
4. FOR STEP DETAILS SEE STANDARD ST-1.
5. DIMENSIONS SHOWN ARE MINIMUM. ACTUAL DIMENSIONS MAY VARY WITH MANUFACTURER.
6. SPACER UNITS SHOWN HEREON ARE ALSO KNOWN AS "GRADE RINGS" OR "ADJUSTMENT RINGS".
7. WHEN SPACER UNITS ARE REQUIRED, "H" IS TO BE MEASURED FROM THE TOP OF THE UPPERMOST SPACER.
8. SPACER UNIT IS TO BE DOWELED OR MORTARED TO TAPER UNIT OR FLAT SLAB TOP.



ROAD AND BRIDGE STANDARDS

STANDARD PRECAST MANHOLE TOP UNITS

SPECIFICATION REFERENCE

SHEET 1 OF 1

REVISION DATE

VIRGINIA DEPARTMENT OF TRANSPORTATION

103.09

105
302

DIMENSIONS	
D	MIN. X
60"	5"
72"	6"
84"	7"
96"	8"

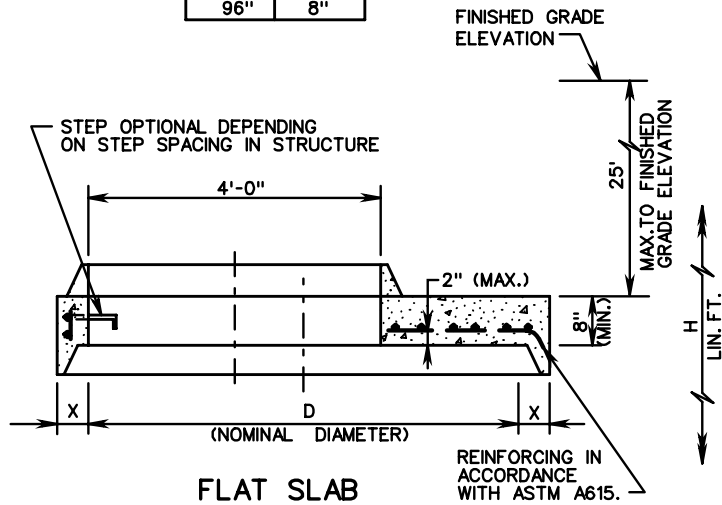

FLAT SLAB
R-2

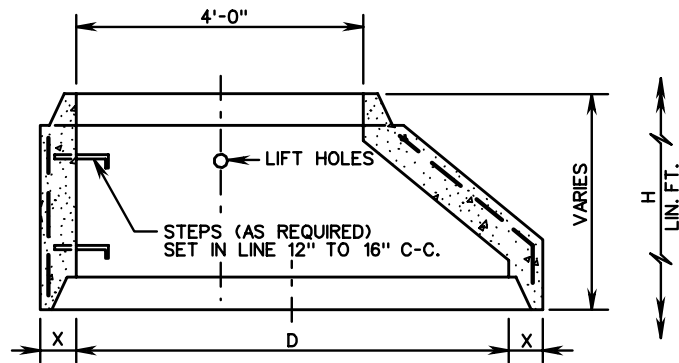

TAPER REDUCER
R-3

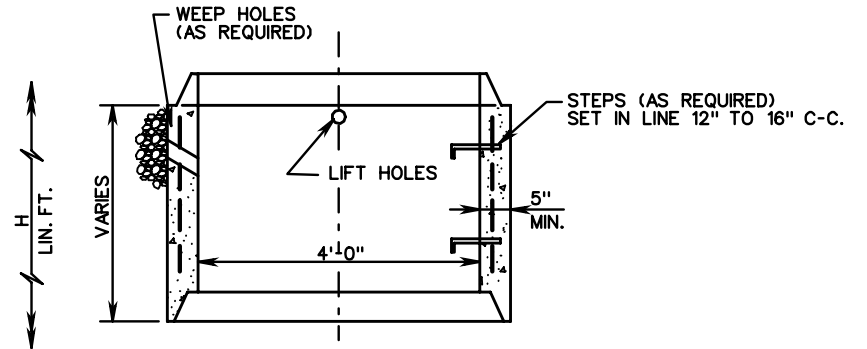

RISER
R-1

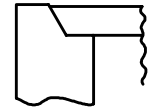

ALTERNATE JOINT DETAIL

NOTES:

1. SEE GENERAL NOTES FOR ADDITIONAL INFORMATION ON WEEP HOLES, STEP REQUIREMENTS, "H" (LIN. FT. FOR MANHOLES) DIMENSIONS, ETC.
2. ALL REDUCER AND RISER UNITS ARE TO BE IN ACCORDANCE WITH THE REQUIREMENTS OF AASHTO M199.
3. CONCRETE SHALL BE 4000 PSI.
4. WHERE OPENINGS ARE REQUIRED FOR PIPE, THEY SHALL BE FORMED, DRILLED, OR NEATLY CUT AS APPROVED BY THE ENGINEER. THE CONTRACTOR SHALL FURNISH THE FABRICATOR WITH THE ANGLES BETWEEN CENTER LINES, THE INVERT ELEVATIONS, AND THE SIZE OF ALL PIPES TO ENTER THE MANHOLE.
5. FOR STEP DETAILS SEE STANDARD ST-1.
6. DIMENSIONS SHOWN ARE MINIMUM. ACTUAL DIMENSIONS MAY VARY WITH MANUFACTURER.
7. "D" IS NOMINAL DIAMETER.
8. WHEN USING R-2 FLAT SLAB, HEIGHT OF STRUCTURE FROM THE SLAB UP TO THE FINISHED GRADE ELEVATION IS LIMITED TO A MAXIMUM OF 25'.
9. TONGUE AND GROOVE JOINT TO BE OF FABRICATOR'S DESIGN MEETING THE APPROVAL OF THE ENGINEER. JOINTS ARE TO BE SEALED WITH MORTAR, O-RING GASKETS, OR BUTYL RUBBER.

SPECIFICATION REFERENCE

105
302

STANDARD PRECAST REDUCER AND RISER UNITS

VIRGINIA DEPARTMENT OF TRANSPORTATION

VDOT

ROAD AND BRIDGE STANDARDS

REVISION DATE

SHEET 1 OF 1

103.10

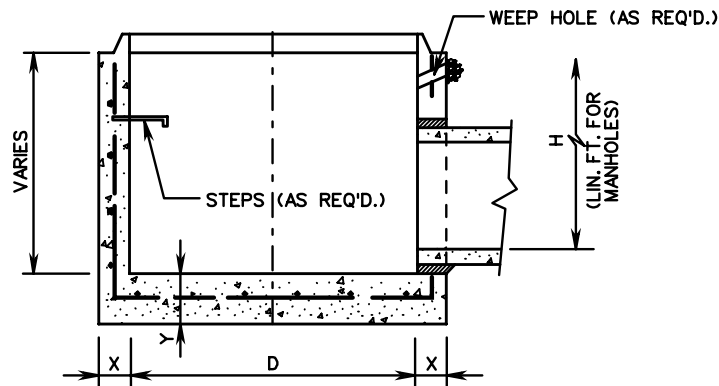

B-1
MONOLITHIC

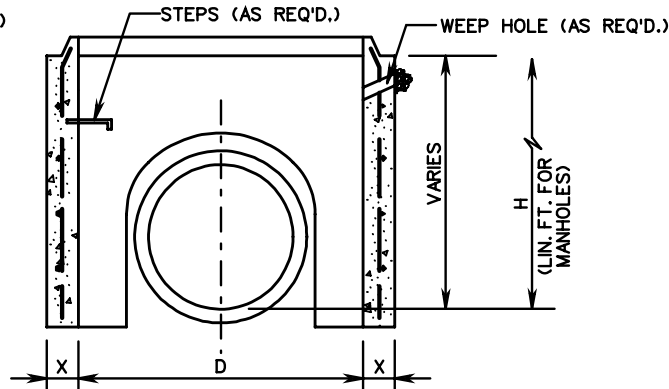

6" x 6" - W5.5 x W5.5 WELDED WIRE FABRIC OR EQUIVALENT AREA

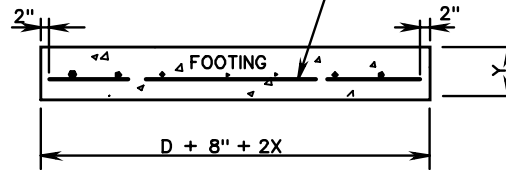

B-2
DOGHOUSE WITH FOOTING

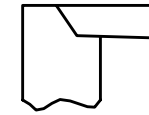

ALTERNATE JOINT
DETAIL

NOTES:

1. SEE GENERAL NOTES FOR ADDITIONAL INFORMATION ON WEEP HOLES, STEP REQUIREMENTS, "H" (LIN. FT. FOR MANHOLES) DIMENSIONS, ETC.
2. ALL BASE UNITS ARE TO BE IN ACCORDANCE WITH THE REQUIREMENTS OF AASHTO M199.
3. CONCRETE SHALL BE 4000 PSI.
4. WHERE OPENINGS ARE REQUIRED FOR PIPE, THEY SHALL BE FORMED, DRILLED, OR NEATLY CUT AS APPROVED BY THE ENGINEER. THE CONTRACTOR SHALL FURNISH THE FABRICATOR WITH THE ANGLES BETWEEN CENTER LINES, THE INVERT ELEVATIONS, AND THE SIZE OF ALL PIPES TO ENTER THE MANHOLE. HOLES ARE TO BE A MINIMUM OF 4" TO A MAXIMUM OF 8" LARGER THAN THE OUTSIDE DIAMETER OF THE PROPOSED PIPE.
5. DIMENSIONS SHOWN ARE MINIMUM. ACTUAL DIMENSIONS MAY VARY WITH MANUFACTURER.
6. "D" IS NOMINAL DIAMETER.
7. IN THE EVENT THE INVERT OF THE OUTFALL PIPE IS HIGHER THAN THE BOTTOM OF THE STRUCTURE, THE INVERT OF THE STRUCTURE SHALL BE SHAPED WITH CEMENT MORTAR TO PREVENT STANDING OR PONDING OF WATER IN THE STRUCTURE.
8. TONGUE AND GROOVE JOINT ARE TO BE OF FABRICATOR'S DESIGN MEETING VDOT APPROVAL. JOINTS ARE TO BE SEALED WITH MORTAR, O-RING GASKETS, OR BUTYL RUBBER.

DIMENSIONS

D	X MINIMUM	Y MINIMUM	SUGGESTED MAX. PIPE SIZE	ABSOLUTE MAXIMUM ☆
* 36"	4"	6"	18"	21"
48"	5"	6"	24"	27"
60"	5"	8"	36"	42"
72"	6"	8"	48"	54"
84"	7"	8"	60"	66"
96"	8"	8"	66"	72"

* DEPTH "H" OF 36" DIAMETER BASE UNIT RESTRICTED TO 4'-0" MAXIMUM.

☆ ONE THROUGH PIPE ONLY. (ONE PIPE ENTERING AND ONE PIPE EXITING STRUCTURE)



ROAD AND BRIDGE STANDARDS

STANDARD PRECAST BASE UNITS

SPECIFICATION
REFERENCE

SHEET 1 OF 1

REVISION DATE

VIRGINIA DEPARTMENT OF TRANSPORTATION

103.11

105
302

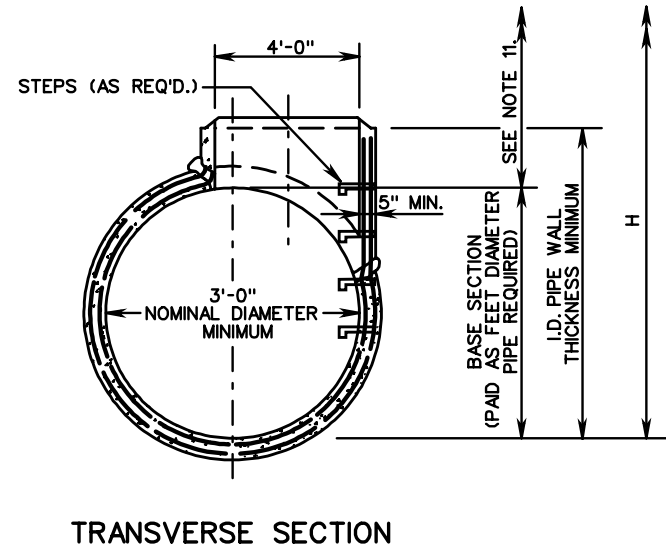
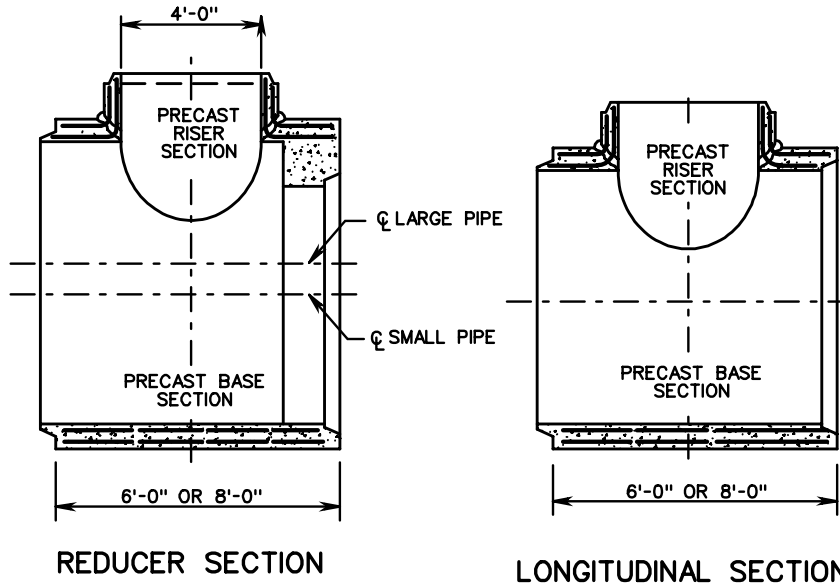

NOTES:

1. SEE GENERAL NOTES FOR ADDITIONAL INFORMATION ON WEEP HOLES, STEP REQUIREMENTS, "H" DIMENSION, ETC.
2. THE TEE UNIT IS TO BE PRECAST FOR DELIVERY TO THE CONSTRUCTION SITE AS A COMPLETE UNIT. ALTERNATE DESIGNS MEETING THE APPROVAL OF THE ENGINEER MAY BE SUBSTITUTED FOR THAT SHOWN HEREON.
3. THE PRECAST BASE SECTION IS TO CONFORM TO THE REQUIREMENTS OF AASHTO M170.
4. THE PRECAST RISER SECTION IS TO CONFORM TO THE REQUIREMENTS OF AASHTO M199, EXCEPT THAT MINIMUM WALL THICKNESS IS TO BE 5".
5. THE BASE SECTION IS TO BE THE SAME CLASS AND STRENGTH AS THE ADJOINING PIPE CULVERT AND THE TONGUE AND GROOVE JOINTS ARE TO BE OF AN IDENTICAL DESIGN.
6. CONCENTRIC RISER SECTION MAY BE SUBSTITUTED WHEN APPROVED BY THE ENGINEER.
7. OTHER MANUFACTURER'S DESIGNS FOR REDUCER SECTION MAY BE SUBSTITUTED WHEN APPROVED BY THE ENGINEER.
8. REDUCER SECTIONS WITH PIPE CROWNS OR CENTER LINES MATCHED ARE AVAILABLE IN ADDITION TO THE MATCHED INVERTS SHOWN HEREON.
9. WELD AND SPLICE LONGITUDINAL AND CIRCUMFERENTIAL STEEL OF RISER AND BASE SECTIONS TO MAINTAIN CONTINUITY OF REINFORCEMENT.
10. HAND OR PNEUMATICALLY PLACE MORTAR AND SHAPE INTO COLLAR.
11. RISER SECTION PAID AS STANDARD DROP INLET OR LIN. FT. MANHOLE DEPENDING ON USE OF STRUCTURE.

TEE SECTION

OPTIONAL VARIATIONS AVAILABLE WHEN SPECIFIED AS A MODIFIED B-3

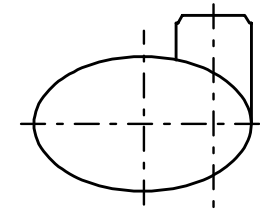

SECTION ELLIPTICAL TEE MANHOLE

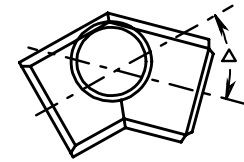

MAX. Δ 90° THRU 72" PIPE

PLAN MANHOLE TEE BEND

SPECIFICATION REFERENCE

105
302

STANDARD PRECAST BASE UNITS

MAX. DEPTH (H) 25'

VIRGINIA DEPARTMENT OF TRANSPORTATION

VDOT

ROAD AND BRIDGE STANDARDS

REVISION DATE

SHEET 1 OF 1

103.12

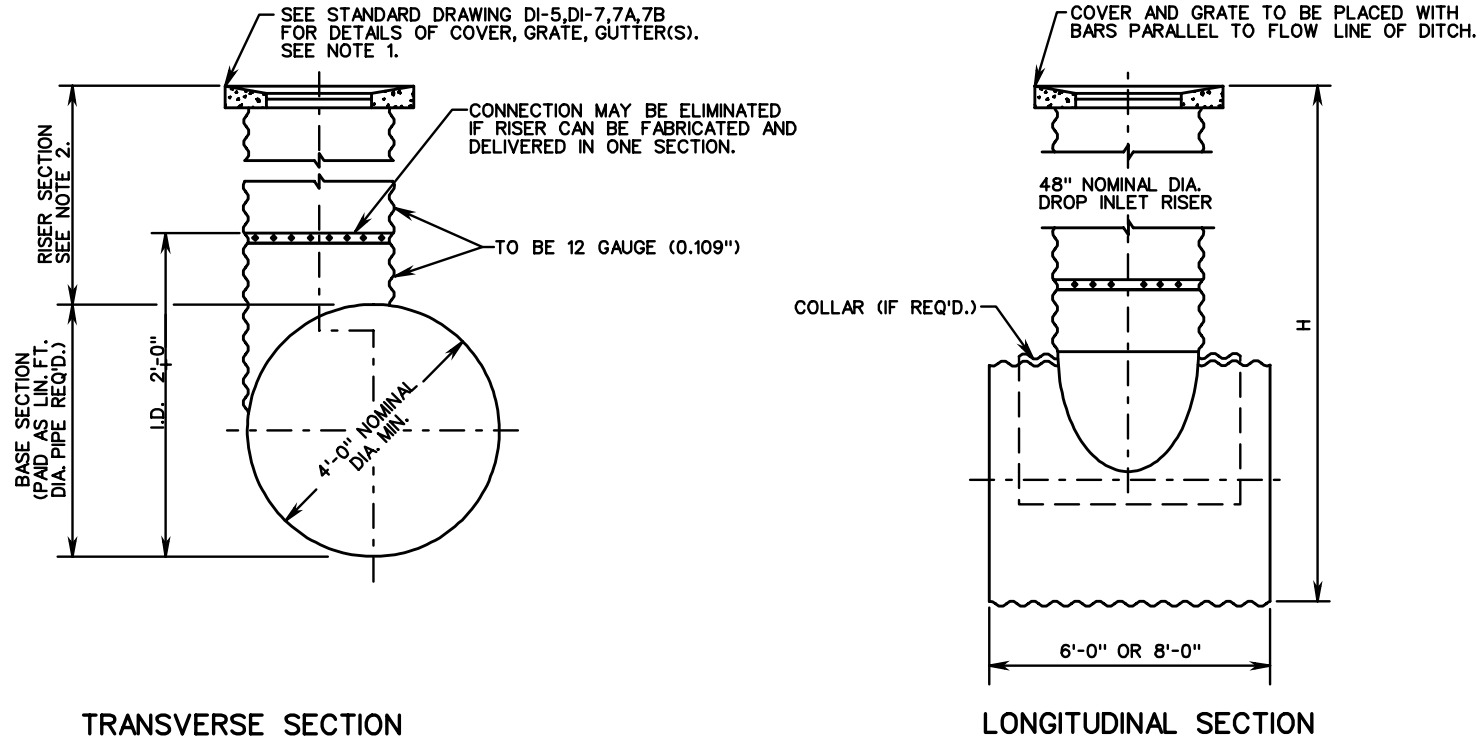

TRANSVERSE SECTION

LONGITUDINAL SECTION

NOTES:

1. OTHER STANDARD GRATES OR DROP INLET THROAT SECTIONS MAY BE SUBSTITUTED WHEN SPECIFIED ON PLANS.
2. RISER SECTION PAID AS STANDARD DROP INLET OR LIN. FT. OF MANHOLE DEPENDING ON USE OF STRUCTURE.
3. THE TEE UNIT IS TO BE FABRICATED FOR DELIVERY TO THE CONSTRUCTION SITE AS A COMPLETE UNIT. ACTUAL DESIGN DETAILS AND METHODS OF CONSTRUCTION WILL BE AT THE OPTION OF THE FABRICATOR AND MEETING THE APPROVAL OF THE ENGINEER, EXCEPT THE SHEET THICKNESS CORRUGATION, AND SPECIFICATIONS TO BE MET WILL BE THE SAME AS THOSE REQUIRED FOR THE ADJOINING PIPE CULVERT. IF ASPHALT COATING IS SPECIFIED FOR THE CULVERT, THE TEE UNIT SHALL ALSO BE COATED.
4. WHEN REQUIRED, CONNECTION BETWEEN DROP INLET RISER AND TEE UNIT MAY BE BOLTED OR RIVETED.

VDOT ROAD AND BRIDGE STANDARDS	
SHEET 1 OF 1	REVISION DATE
103.13	

CORRUGATED METAL TEE SECTION
MAX. DEPTH (H) 25'
VIRGINIA DEPARTMENT OF TRANSPORTATION

SPECIFICATION REFERENCE
302

THIS PAGE INTENTIONALLY LEFT BLANK

SPECIFICATION
REFERENCE

VIRGINIA DEPARTMENT OF TRANSPORTATION



ROAD AND BRIDGE STANDARDS

REVISION DATE

SHEET 1 OF 1

103.14

DI-1

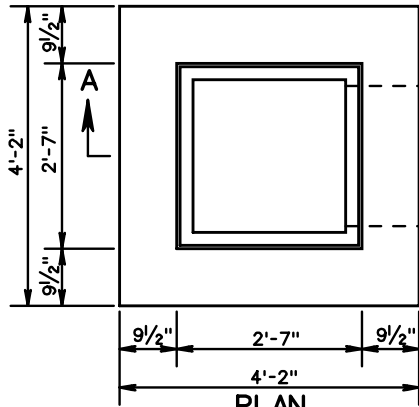

PLAN
(GRATE REMOVED)

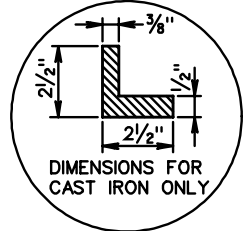

DETAIL A

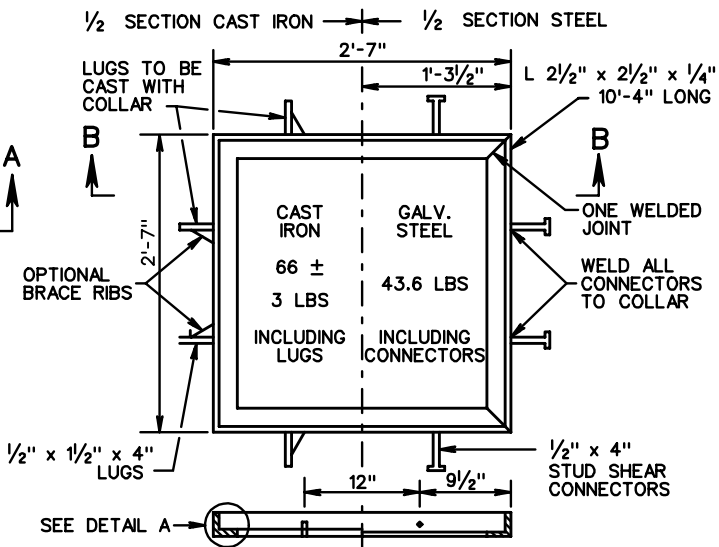

SECTION B-B
COLLAR DETAIL

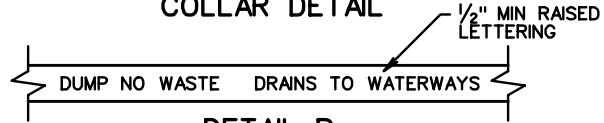

DETAIL B

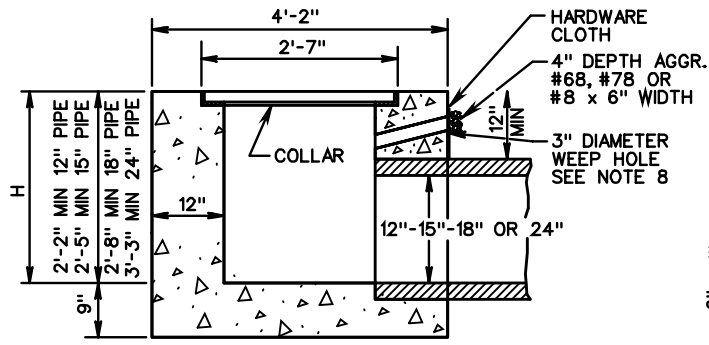

SECTION A-A

CONCRETE QUANTITIES FOR MIN. DEPTH

- 12" CONCRETE PIPE - 1.440 CU. YD. CONCRETE
- 15" CONCRETE PIPE - 1.528 CU. YD. CONCRETE
- 18" CONCRETE PIPE - 1.620 CU. YD. CONCRETE
- 24" CONCRETE PIPE - 1.817 CU. YD. CONCRETE

ADD 0.469 CU. YD. PER
ADDITIONAL FOOT OF DEPTH.

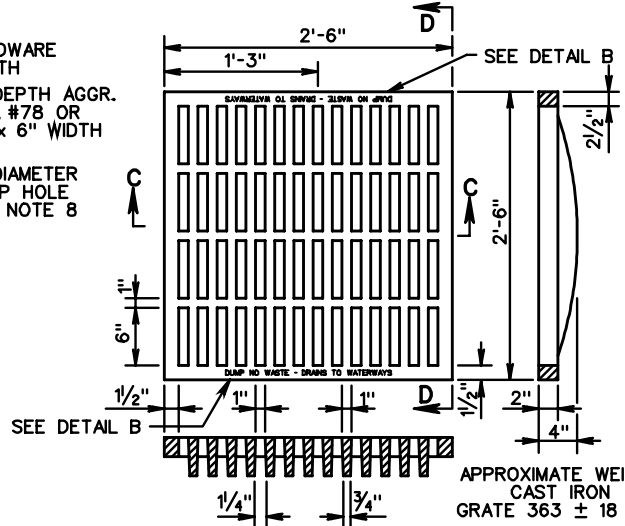

SECTION C-C SECTION D-D
GRATE DETAIL

NOTES

1. DEPTH OF INLET (H) TO BE SHOWN ON PLANS. FOR DEPTH GREATER THAN 10' USE STANDARD DI-1A
2. THE "H" DIMENSION SHOWN ON THE STANDARDS AND SPECIFIED ON THE PLANS WILL BE MEASURED FROM THE INVERT OF THE OUTFALL PIPE TO THE TOP OF THE STRUCTURE. PLAN "H" DIMENSIONS ARE APPROXIMATE ONLY FOR ESTIMATING PURPOSES AND THE ACTUAL DIMENSIONS SHALL BE DETERMINED BY THE CONTRACTOR FROM FIELD CONDITIONS.
3. WHEN SPECIFIED ON THE PLANS THE INVERT IS TO BE SHAPED IN ACCORDANCE WITH STANDARD IS-1. THE COST OF FURNISHING AND PLACING ALL MATERIALS INCIDENTAL TO THE SHAPING IS TO BE INCLUDED IN THE BID PRICE FOR THE STRUCTURE.
4. IN THE EVENT THE INVERT OF THE OUTFALL PIPE IS HIGHER THAN THE BOTTOM OF THE STRUCTURE, THE INVERT OF THE STRUCTURE SHALL BE SHAPED WITH CEMENT MORTAR TO PREVENT STANDING OR PONDING OF WATER IN THE STRUCTURE. THE COST OF FURNISHING AND PLACING ALL MATERIALS INCIDENTAL TO INLET SHAPING IS TO BE INCLUDED IN THE BID PRICE FOR THE STRUCTURE.
5. STEPS ARE TO BE PROVIDED WHEN H IS 4'-0" OR GREATER. FOR DETAILS SEE STANDARD ST-1.
6. THIS ITEM MAY BE PRECAST OR CAST-IN-PLACE.
7. #4 X 8" SMOOTH DOWELS AT APPROXIMATELY 12" C-C TO BE PLACED IN ALL AREAS ADJACENT TO ABUTTING CONCRETE TO PREVENT SETTLEMENT. IN LIEU OF DOWELS A 2"X4" NOTCH MAY BE PROVIDED. SEE STANDARD T-DI-3, 4 FOR ALTERNATE DESIGN.
8. 3" DIAMETER WEEP HOLE WITH 12"X12" PLASTIC HARDWARE CLOTH 1/4" MESH OR GALVANIZED STEEL WIRE, MINIMUM WIRE DIAMETER 0.03", NUMBER 4 MESH HARDWARE CLOTH ANCHORED FIRMLY TO THE OUTSIDE OF THE STRUCTURE.
9. CAST IN PLACE CONCRETE IS TO BE CLASS A3 (3000 PSI). PRECAST CONCRETE IS TO BE 4000 PSI.
10. ANY ALTERNATE METHODS OF ANCHORAGE MEETING THE APPROVAL OF THE ENGINEER MAY BE SUBSTITUTED FOR THE CAST IRON LUGS AS SHOWN HEREON.
11. DUMP NO WASTE DRAINS TO WATERWAY LETTERING IS REQUIRED ON ALL DI-1 GRATES. LOCATION OF LETTERING MAY VARY BY MANUFACTURER.



ROAD AND BRIDGE STANDARDS

SHEET 1 OF 1

REVISION DATE

104.01

STANDARD DROP INLET

12" - 24" PIPE: MAXIMUM DEPTH (H) - 10'

VIRGINIA DEPARTMENT OF TRANSPORTATION

SPECIFICATION
REFERENCE

233
302

NOTES

1. DEPTH OF INLET (H) TO BE SHOWN ON PLANS. MAXIMUM DEPTH (H) TO BE 20'. FOR DEPTHS LESS THAN 10' USE STANDARD DI-1.
2. THE "H" DIMENSION SHOWN ON THE STANDARDS AND SPECIFIED ON THE PLANS WILL BE MEASURED FROM THE INVERT OF THE OUTFALL PIPE TO THE TOP OF THE STRUCTURE. PLAN "H" DIMENSIONS ARE APPROXIMATE ONLY FOR ESTIMATING PURPOSES AND THE ACTUAL DIMENSIONS SHALL BE DETERMINED BY THE CONTRACTOR FROM FIELD CONDITIONS.
3. WHEN SPECIFIED ON THE PLANS THE INVERT IS TO BE SHAPED IN ACCORDANCE WITH STANDARD IS-1. THE COST OF FURNISHING AND PLACING ALL MATERIALS INCIDENTAL TO THE SHAPING IS TO BE INCLUDED IN THE BID PRICE FOR THE STRUCTURE.
4. IN THE EVENT THE INVERT OF THE OUTFALL PIPE IS HIGHER THAN THE BOTTOM OF THE STRUCTURE, THE INVERT OF THE STRUCTURE SHALL BE SHAPED WITH CEMENT MORTAR TO PREVENT STANDING OR PONDING OF WATER IN THE STRUCTURE. THE COST OF FURNISHING AND PLACING ALL MATERIALS INCIDENTAL TO THE SHAPING IS TO BE INCLUDED IN THE BID PRICE FOR THE STRUCTURE.
5. STEPS ARE REQUIRED. FOR DETAILS SEE ST'D. ST-1.
6. THIS ITEM MAY BE PRECAST OR CAST-IN-PLACE.
7. # 4 X 8" SMOOTH DOWELS AT APPROXIMATELY 12" C-C TO BE PLACED IN ALL AREAS ADJACENT TO ABUTTING CONCRETE TO PREVENT SETTLEMENT. IN LIEU OF DOWELS A 2" X 4" NOTCH MAY BE PROVIDED. SEE STANDARD T-DI-3, 4 FOR ALTERNATE DESIGN.
8. 3" DIAMETER WEEP HOLE WITH 12"X12" PLASTIC HARDWARE CLOTH 1/4" MESH OR GALVANIZED STEEL WIRE, MINIMUM WIRE DIAMETER 0.03", NUMBER 4 MESH HARDWARE CLOTH ANCHORED FIRMLY TO THE OUTSIDE OF THE STRUCTURE.
9. ALL REINFORCING STEEL SHALL HAVE A MIN. COVER OF 2".
10. ALL REINFORCING STEEL TO BE CUT CLEAR OF ALL OPENINGS BY 2".
11. CAST-IN PLACE CONCRETE IS TO BE CLASS A3 (3000 PSI). PRECAST CONCRETE IS TO BE 4000 PSI.
12. ALL SPLICES IN BARS V TO BE A MINIMUM OF 40 DIAMETERS (20").
13. IF OPTIONAL CONSTRUCTION JOINT IS USED, IT IS TO BE KEYED.
14. FOR DETAILS AND DIMENSIONS, ETC. OF GRATE AND STEEL OR CAST IRON COLLAR SEE STANDARD DI-1.

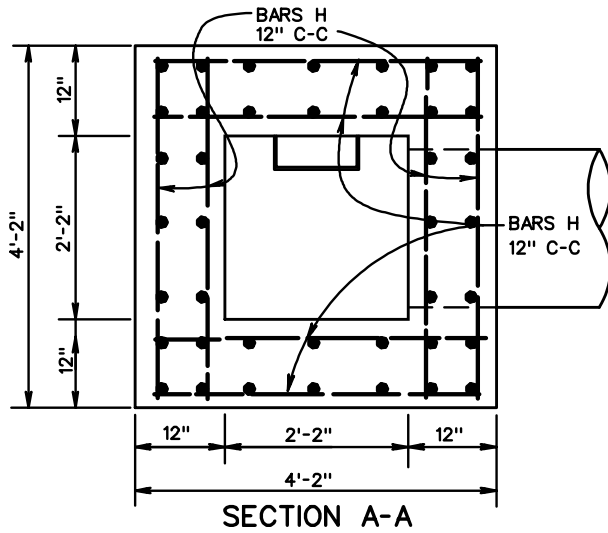

SECTION A-A

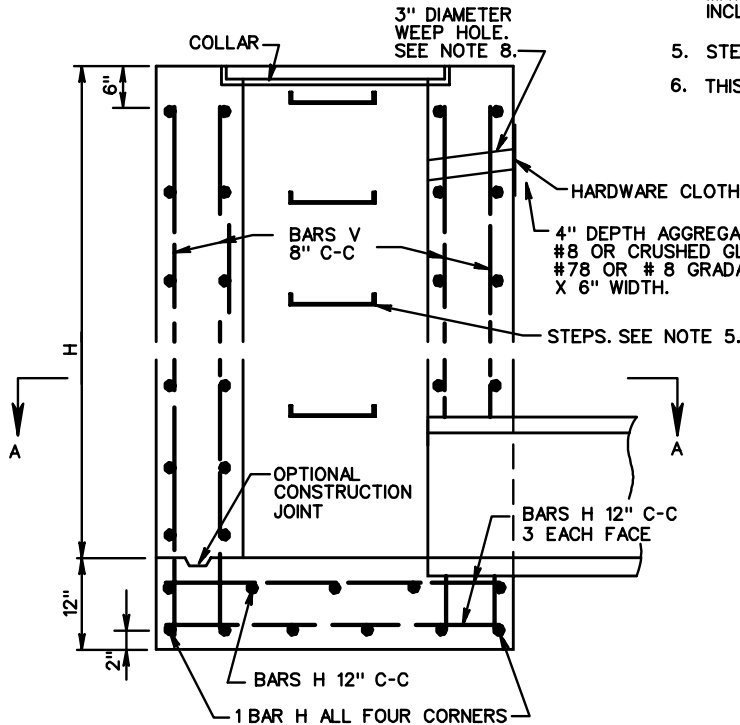

SECTION THROUGH ELEVATION

REINFORCING STEEL SCHEDULE			
MARK	SIZE	NO REQ'D	LENGTH
BARS H	#5	8x(H + 2)	3'-10"
BARS V	#4	40	H + 4"

APPROXIMATE QUANTITIES FOR MINIMUM (10') DEPTH		
CONCRETE PIPE DIAMETER	CONCRETE	REINF. STEEL
	CU. YDS.	Lbs.
12"	5.218	655
15"	5.193	651
18"	5.163	647
24"	5.089	639

INCREMENTS TO BE ADDED FOR EACH ADDITIONAL FOOT OF DEPTH (H):
 0.465 CU. YDS. OF CONCRETE
 58.7 LBS. OF REINFORCING STEEL

SPECIFICATION REFERENCE

233
302

STANDARD DROP INLET
 12" - 24" PIPE: DEPTH (H) 10' TO 20'
 VIRGINIA DEPARTMENT OF TRANSPORTATION

VDOT

ROAD AND BRIDGE STANDARDS

REVISION DATE

SHEET 1 OF 1

104.02

DI-2A, 2B, 2C

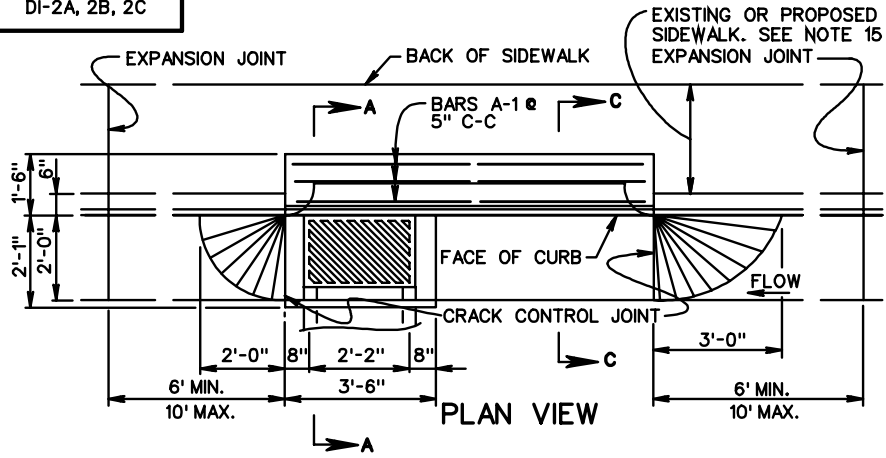

PLAN VIEW

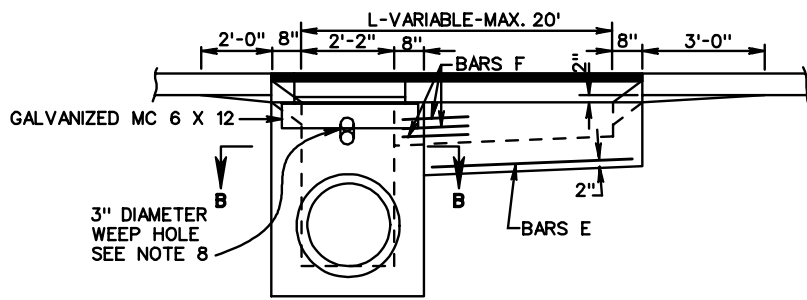

FRONT ELEVATION

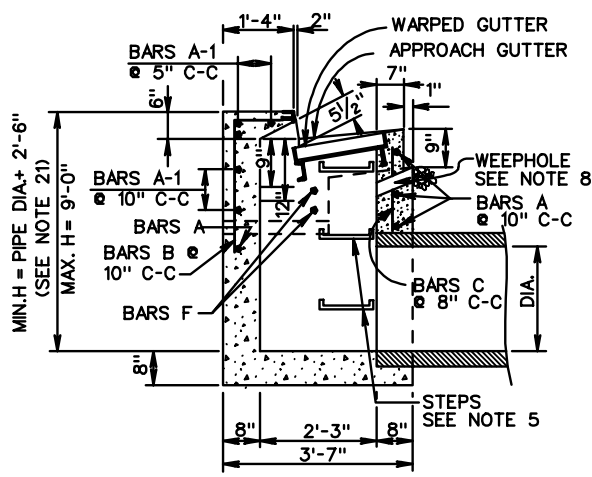
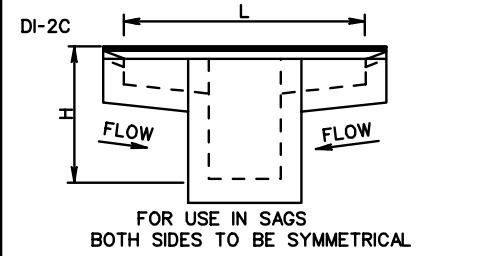
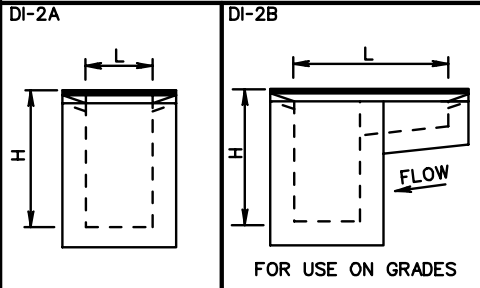

SECTION A-A
FOR STEP DETAILS SEE STD. ST-1.

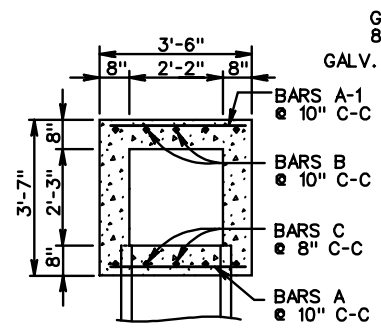

SECTION B-B

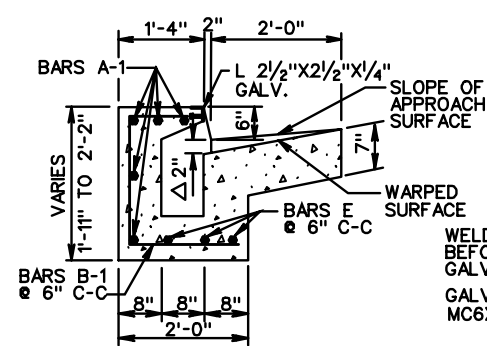

SECTION C-C
Δ DECREASE TO 1" WHEN INLET IS USED WITH MEDIANS.

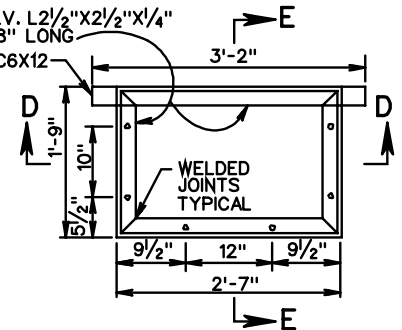

COLLAR

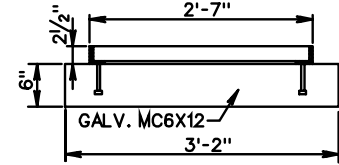

SECTION D-D

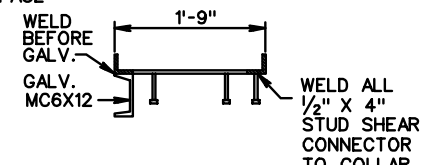

SECTION E-E

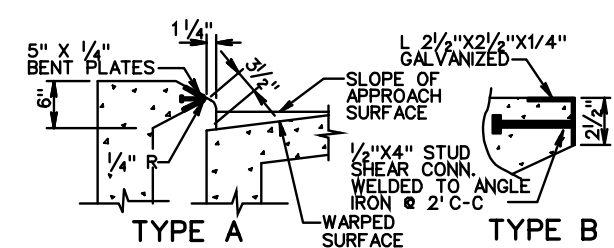

NOSE DETAILS

TYPE A NOSE DETAIL SHALL BE USED WITH CG-7 STANDARD. TYPE B NOSE DETAIL SHALL BE USED WITH CG-6 STANDARD. GALVANIZED PLATE FOR TYPE A TO BE BENT ON AN ANGLE OF 68° 30' AND IS TO BE ANCHORED WITH 1/2" X 4" STUD SHEAR CONNECTORS WELDED TO BENT PLATE AT 2' C-C.

VDOT	
ROAD AND BRIDGE STANDARDS	
SHEET 1 OF 2	REVISION DATE
104.03	

STANDARD CURB DROP INLET

12" - 24" PIPE: MAXIMUM DEPTH (H) = 9'

VIRGINIA DEPARTMENT OF TRANSPORTATION

SPECIFICATION REFERENCE
233 302

TABLE OF QUANTITIES

DI-2A, 2B, 2C

TYPE	L	REINFORCING STEEL														WEIGHT		
		CONCRETE		BARS A		BARS A-1		BARS B		BARS B-1		BARS C		BARS E			BARS F	
		Ft.	Cu. Yds.	No.	Lin. Ft.*	No.	Lin. Ft.*	No.	Lin. Ft.*	No.	Lin. Ft.*	No.	Lin. Ft.*	No.	Lin. Ft.*		No.	Lin. Ft.*
DI-2A	2'-2"	1.71	4	3'-2"	5	3'-2"	4	3'-6"	-	-	5	2'-0"	-	-	-	1'-6"	55	
	4'	1.95	4	3'-2"	5	5'-0"	4	3'-6"	3	4'-3" to 4'-6"	5	2'-0"	3	2'-0"	3	1'-6"	84	
DI-2B	6'	2.23	4	3'-2"	5	7'-0"	4	3'-6"	7	4'-3" to 4'-6"	5	2'-0"	3	4'-0"	3	1'-6"	119	
	8'	2.51	4	3'-2"	5	9'-0"	4	3'-6"	11	4'-3" to 4'-6"	5	2'-0"	3	6'-0"	3	1'-6"	154	
	10'	2.79	4	3'-2"	5	11'-0"	4	3'-6"	15	4'-3" to 4'-6"	5	2'-0"	3	8'-0"	3	1'-6"	189	
	12'	3.05	4	3'-2"	5	13'-0"	4	3'-6"	19	4'-3" to 4'-6"	5	2'-0"	3	10'-0"	3	1'-6"	224	
	14'	3.34	4	3'-2"	5	15'-0"	4	3'-6"	23	4'-3" to 4'-6"	5	2'-0"	3	12'-0"	3	1'-6"	259	
	16'	3.61	4	3'-2"	5	17'-0"	4	3'-6"	27	4'-3" to 4'-6"	5	2'-0"	3	14'-0"	3	1'-6"	294	
	18'	3.89	4	3'-2"	5	19'-0"	4	3'-6"	31	4'-3" to 4'-6"	5	2'-0"	3	16'-0"	3	1'-6"	329	
	20'	4.17	4	3'-2"	5	21'-0"	4	3'-6"	35	4'-3" to 4'-6"	5	2'-0"	3	18'-0"	3	1'-6"	364	
DI-2C	6'	2.24	4	3'-2"	5	7'-0"	4	3'-6"	6	4'-3" to 4'-6"	5	2'-0"	6	2'-1"	6	1'-6"	115	
	8'	2.55	4	3'-2"	5	9'-0"	4	3'-6"	10	4'-3" to 4'-6"	5	2'-0"	6	3'-1"	6	1'-6"	150	
	10'	2.82	4	3'-2"	5	11'-0"	4	3'-6"	14	4'-3" to 4'-6"	5	2'-0"	6	4'-1"	6	1'-6"	185	
	12'	3.09	4	3'-2"	5	13'-0"	4	3'-6"	18	4'-3" to 4'-6"	5	2'-0"	6	5'-1"	6	1'-6"	220	
	14'	3.37	4	3'-2"	5	15'-0"	4	3'-6"	22	4'-3" to 4'-6"	5	2'-0"	6	6'-1"	6	1'-6"	255	
	16'	3.65	4	3'-2"	5	17'-0"	4	3'-6"	26	4'-3" to 4'-6"	5	2'-0"	6	7'-1"	6	1'-6"	290	
	18'	3.93	4	3'-2"	5	19'-0"	4	3'-6"	30	4'-3" to 4'-6"	5	2'-0"	6	8'-1"	6	1'-6"	325	
	20'	4.20	4	3'-2"	5	21'-0"	4	3'-6"	34	4'-3" to 4'-6"	5	2'-0"	6	9'-1"	6	1'-6"	360	

NOTES

- DEPTH OF INLET (H) TO BE SHOWN ON PLANS.
- THE "H" DIMENSION SHOWN ON THE STANDARDS AND SPECIFIED ON THE PLANS WILL BE MEASURED FROM THE INVERT OF THE OUTFALL PIPE TO THE TOP OF THE STRUCTURE. PLAN "H" DIMENSIONS ARE APPROXIMATE ONLY FOR ESTIMATING PURPOSES AND THE ACTUAL DIMENSIONS SHALL BE DETERMINED BY THE CONTRACTOR FROM FIELD CONDITIONS.
- WHEN SPECIFIED ON THE PLANS THE INVERT IS TO BE SHAPED IN ACCORDANCE WITH STANDARD IS-1. THE COST OF FURNISHING AND PLACING ALL MATERIALS INCIDENTAL TO THE SHAPING IS TO BE INCLUDED IN THE BID PRICE FOR THE STRUCTURE.
- IN THE EVENT THE INVERT OF THE OUTFALL PIPE IS HIGHER THAN THE BOTTOM OF THE STRUCTURE, THE INVERT OF THE STRUCTURE SHALL BE SHAPED WITH CEMENT MORTAR TO PREVENT STANDING OR PONDING OF WATER IN THE STRUCTURE. THE COST OF FURNISHING AND PLACING ALL MATERIALS INCIDENTAL TO THE SHAPING IS TO BE INCLUDED IN THE BID PRICE FOR THE STRUCTURE.
- STEPS ARE TO BE PROVIDED WHEN H IS 4'-0" OR GREATER. FOR DETAILS SEE STANDARD ST-1.
- THIS ITEM MAY BE PRECAST OR CAST-IN-PLACE.
- # 4 X 8" SMOOTH DOWELS AT APPROXIMATELY 12" C-C TO BE PLACED IN ALL AREAS ADJACENT TO ABUTTING CONCRETE TO PREVENT SETTLEMENT.
- 3" DIAMETER WEEP HOLE TO BE LOCATED TO DRAIN SUBBASE MATERIAL. WEEP HOLE WITH 12"X12" PLASTIC HARDWARE CLOTH 1/4" MESH OR GALVANIZED STEEL WIRE, MINIMUM WIRE DIAMETER 0.03", NUMBER 4 MESH HARDWARE CLOTH ANCHORED FIRMLY TO THE OUTSIDE OF THE STRUCTURE.
- ALL REINFORCING STEEL SHALL HAVE A MINIMUM COVER OF 2".
- ALL REINFORCING STEEL TO BE CUT CLEAR OF ALL OPENINGS BY 2".
- CAST-IN PLACE CONCRETE IS TO BE CLASS A3 (3000 PSI). PRECAST CONCRETE IS TO BE 4000 PSI.
- LENGTH OF SLOT (L) WILL, IN EVERY CASE, BE SHOWN ON PLANS.
- THIS STANDARD IS INTENDED FOR USE IN CURB AND GUTTER SITUATIONS ONLY.
- STANDARD INLETS MAY BE CONSTRUCTED WITH CONCRETE BLOCKS IN ACCORDANCE WITH THE DETAILS SHOWN ON STANDARD DRAWING DI-MB.
- THIS AREA MAY BE EARTHEN, IN WHICH CASE THE EXPANSION JOINTS WILL APPLY ONLY TO CURB AND GUTTER.
- CONCRETE QUANTITIES SHOWN ARE FOR DEPTH (H) OF 5'-2" WITHOUT PIPES. THE AMOUNT DISPLACED BY PIPES MUST BE DEDUCTED TO OBTAIN TRU QUANTITIES. FOR INLETS OF DIFFERENT DEPTHS ADD OR SUBTRACT 0.28 CUBIC YARDS OF CONCRETE FOR EACH FOOT.
- LENGTH OF ANGLE IRON AS SHOWN ON SHEET 1 OF 2 IS TO BE L 16" AT 4.10 LBS./FT.
- * DENOTES LENGTH OF ONE (1) BAR.
- ALL REINFORCING BARS TO BE #5.
- GRATE TO BE INSTALLED SO SLOTS WILL DIRECT WATER TOWARD THE INLET THROAT.
- MINIMUM HEIGHT = PIPE DIA. + 2'-6" WHEN PIPES ARE LOCATED UNDER EXTENDED SLOT OF INLET.
- DUMP NO WASTE DRAINS TO WATERWAYS LETTERING IS REQUIRED ON ALL DI-2 GRATES. LOCATION OF LETTERING MAY VARY BY MANUFACTURER.

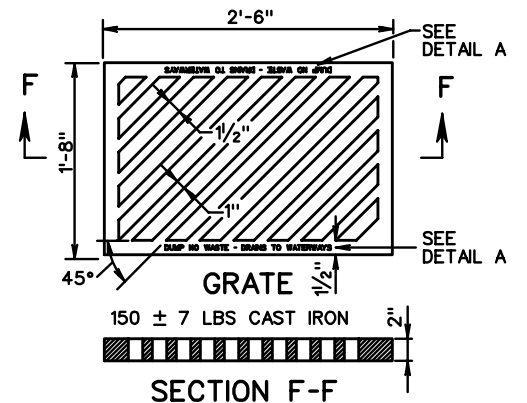
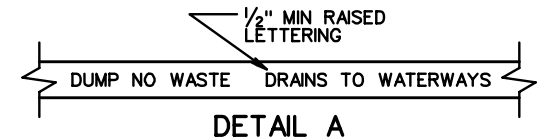

SPECIFICATION REFERENCE

233
302

STANDARD CURB DROP INLET

12" - 24" PIPE: MAXIMUM DEPTH (H)-9'

VIRGINIA DEPARTMENT OF TRANSPORTATION

VDOT

ROAD AND BRIDGE STANDARDS

REVISION DATE

SHEET 2 OF 2

104.04

NOTES

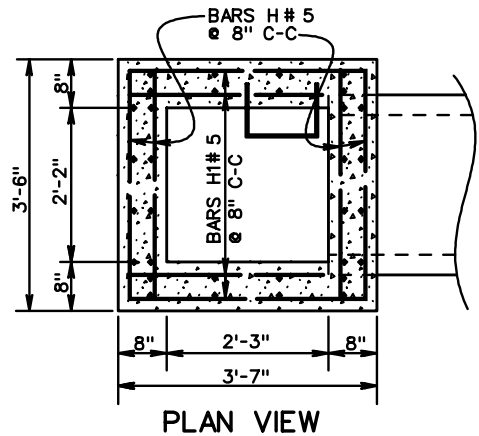

1. DEPTH OF INLET (H) TO BE SHOWN ON PLANS. MAXIMUM DEPTH (H) TO BE 20'. FOR DEPTHS LESS THAN 9' USE STANDARD DI-2A, 2B OR 2C.
2. THE "H" DIMENSION SHOWN ON THE STANDARDS AND SPECIFIED ON THE PLANS WILL BE MEASURED FROM THE INVERT OF THE OUTFALL PIPE TO THE TOP OF THE STRUCTURE. PLAN "H" DIMENSIONS ARE APPROXIMATE ONLY FOR ESTIMATING PURPOSES AND THE ACTUAL DIMENSIONS SHALL BE DETERMINED BY THE CONTRACTOR FROM FIELD CONDITIONS.
3. WHEN SPECIFIED ON THE PLANS THE INVERT IS TO BE SHAPED IN ACCORDANCE WITH STANDARD IS-1. THE COST OF FURNISHING AND PLACING ALL MATERIALS INCIDENTAL TO THE SHAPING IS TO BE INCLUDED IN THE BID PRICE FOR THE STRUCTURE.
4. IN THE EVENT THE INVERT OF THE OUTFALL PIPE IS HIGHER THAN THE BOTTOM OF THE STRUCTURE, THE INVERT OF THE STRUCTURE SHALL BE SHAPED WITH CEMENT MORTAR TO PREVENT STANDING OR PONDING OF WATER IN THE STRUCTURE. THE COST OF FURNISHING AND PLACING ALL MATERIALS INCIDENTAL TO THE SHAPING IS TO BE INCLUDED IN THE BID PRICE FOR THE STRUCTURE.
5. STEPS ARE TO BE PROVIDED. FOR DETAILS SEE STANDARD ST-1.
6. THIS ITEM MAY BE PRECAST OR CAST-IN-PLACE.
7. #4 X 8" SMOOTH DOWELS AT APPROXIMATELY 12" C-C TO BE PLACED IN ALL AREAS ADJACENT TO ABUTTING CONCRETE TO PREVENT SETTLEMENT. IN LIEU OF DOWELS A 2" X 4" NOTCH MAY BE PROVIDED. SEE STANDARD T-DI-3, 4 FOR ALTERNATE DESIGN.
8. 3" DIAMETER WEEP HOLE IS TO BE LOCATED TO DRAIN SUBBASE MATERIAL. WEEP HOLE WITH 12" X 12" PLASTIC HARDWARE CLOTH 1/4" MESH OR GALVANIZED STEEL WIRE, MINIMUM WIRE DIAMETER 0.03", NUMBER 4 MESH HARDWARE CLOTH ANCHORED FIRMLY TO THE OUTSIDE OF THE STRUCTURE.
9. ALL REINFORCING STEEL SHALL HAVE A MIN. COVER OF 2".
10. ALL REINFORCING STEEL TO BE CUT CLEAR OF ALL OPENINGS BY 2".
11. CAST-IN- PLACE CONCRETE IS TO BE CLASS A3 (3000 PSI). PRECAST CONCRETE IS TO BE 4000 PSI.
12. LENGTH OF SLOT (L) WILL, IN EVERY CASE, BE SHOWN ON PLANS.
13. THIS STANDARD IS INTENDED FOR USE IN CURB AND GUTTER SITUATIONS ONLY.
14. IF OPTIONAL CONSTRUCTION JOINT IS USED IT IS TO BE KEYS. ALL SPLICES IN BARS V TO BE A MINIMUM OF 40 DIAMETERS (20").
15. FOR PLAN VIEW OF INLET SEE STANDARD DI-2A, 2B, 2C.
16. FOR DESCRIPTION AND LOCATION OF DIMENSION L SEE SHEET 104.03.
17. FOR NUMBER OF BARS A-F REQUIRED AND LENGTHS SEE SHEET 104.04.
18. QUANTITIES SHOWN ARE FOR MINIMUM INLETS OF EACH TYPE. FOR INLETS OF GREATER DEPTHS (H) OR LONGER SLOTS (L) INCREMENTS SHOWN PER FOOT MUST BE ADDED. THE AMOUNT OF CONCRETE AND STEEL DISPLACED BY PIPES MUST BE DEDUCTED TO OBTAIN TRUE QUANTITIES.
19. FOR DETAILS AND DIMENSIONS OF CURB, SLOT, BEAM, COLLAR AND GRATE, DROPPED GUTTER LINE, AND REINFORCING AND STRUCTURAL STEEL NOT DETAILED SEE STANDARD DI-2A.

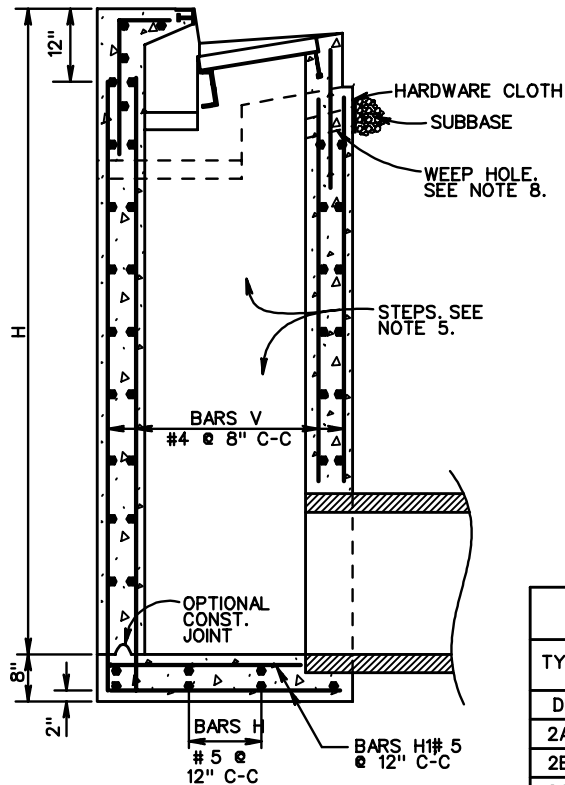

SECTION THROUGH ELEVATION

INCREMENTS TO BE ADDED FOR EACH ADDITIONAL FEET OF DEPTH (H) AND, OR SLOT LENGTH (L)			
H		L	
CONCRETE	STEEL	CONCRETE	STEEL
Cu. Yds.	Lbs.	Cu. Yds.	Lbs.
0.28	64	-	-
0.28	64	0.16	17
0.28	64	0.16	17

APPROXIMATE QUANTITIES FOR MINIMUM 9" DEPTH INLET			
TYPE	DIMENSION L SEE NOTE 16	REINFORCING STEEL	CONCRETE
	Lin. Ft.	Lbs.	Cu. Yds.
DI-	2'-2"	609	2.77
2AA	4'-0"	647	3.06
2CC	6'-0"	685	3.38

SCHEDULE OF REINFORCING STEEL SEE NOTE 17					
BARS H		BARS H1		BARS V	
NO REQ'D.	LENGTH	NO REQ'D.	LENGTH	NO REQ'D.	LENGTH
4(1.5H + 1) + 8	3'-2"	4(1.5H + 1) + 8	3'-3"	36	H-(1'-4")

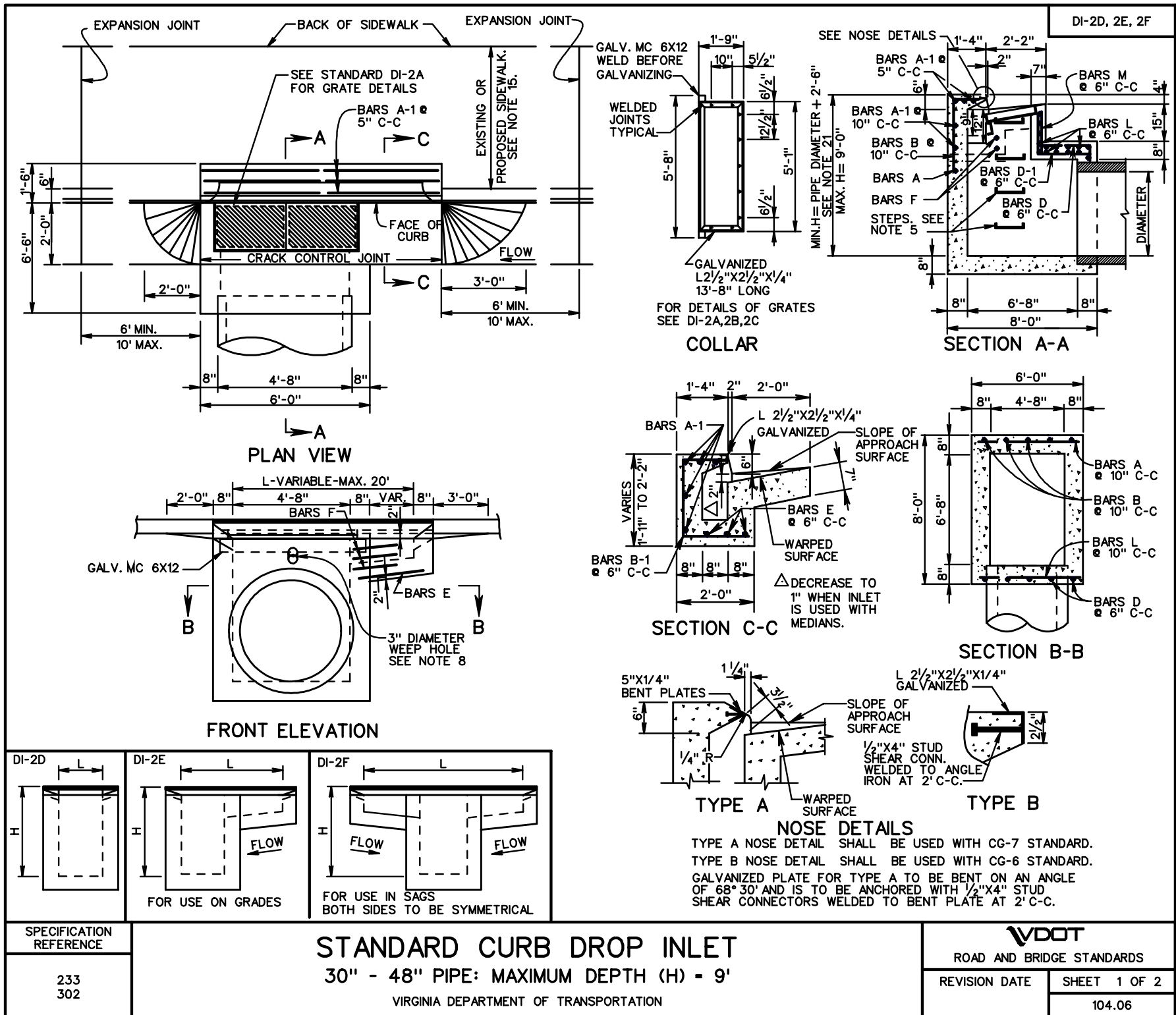

DI-2D, 2E, 2F

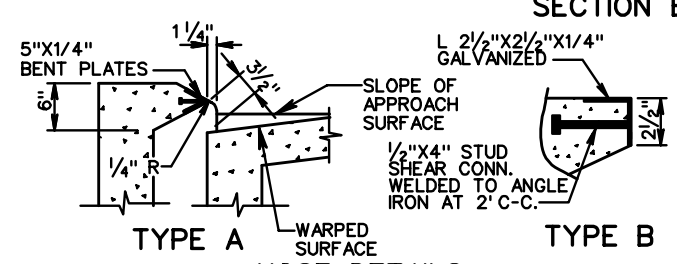
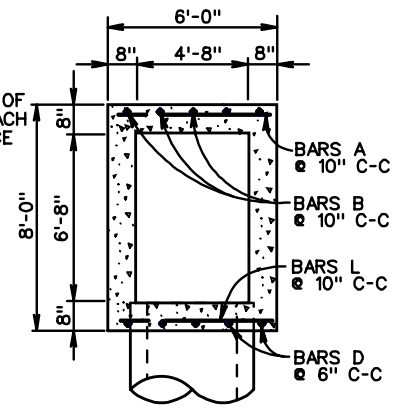
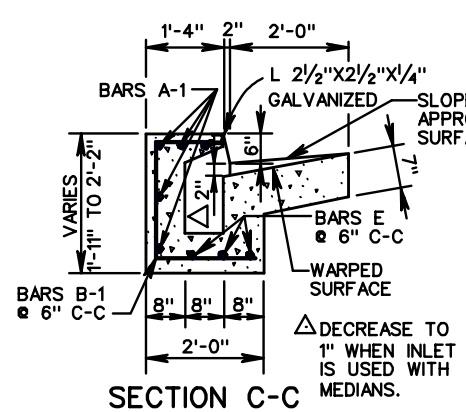
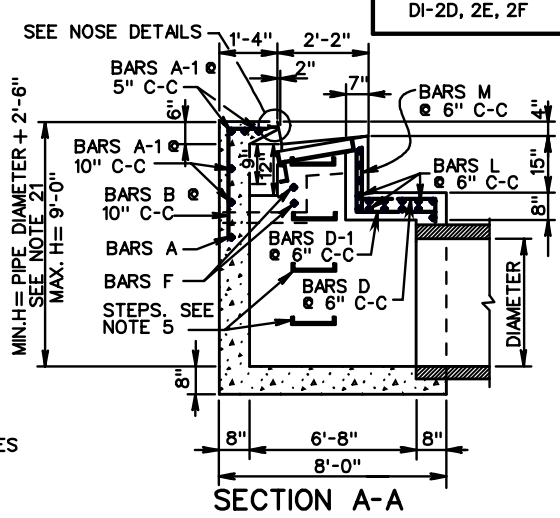
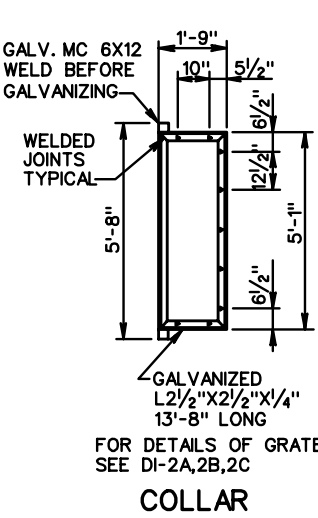
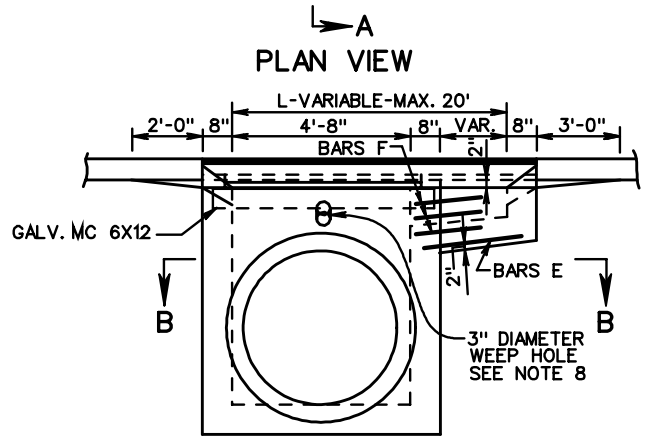
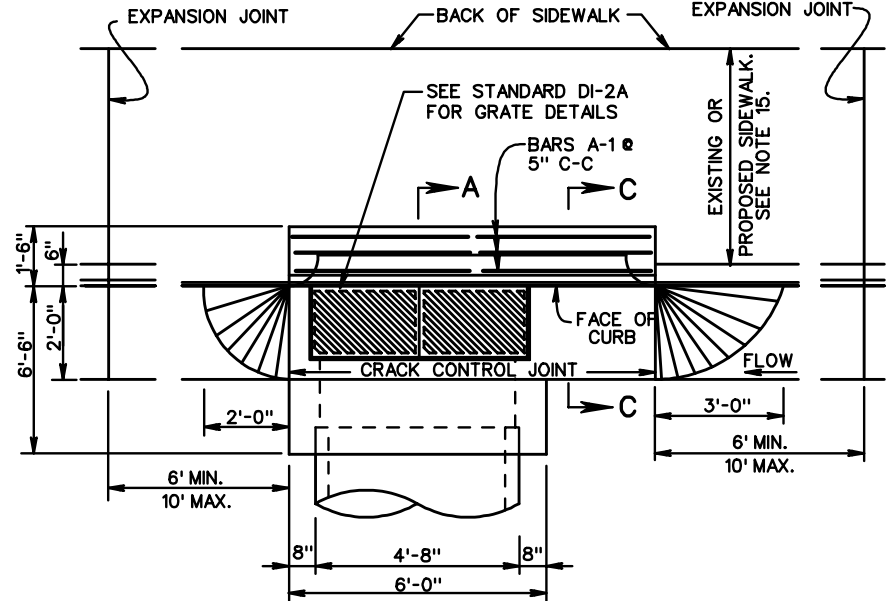

NOSE DETAILS
 TYPE A NOSE DETAIL SHALL BE USED WITH CG-7 STANDARD.
 TYPE B NOSE DETAIL SHALL BE USED WITH CG-6 STANDARD.
 GALVANIZED PLATE FOR TYPE A TO BE BENT ON AN ANGLE OF 68° 30' AND IS TO BE ANCHORED WITH 1/2" X 4" STUD SHEAR CONNECTORS WELDED TO BENT PLATE AT 2' C-C.

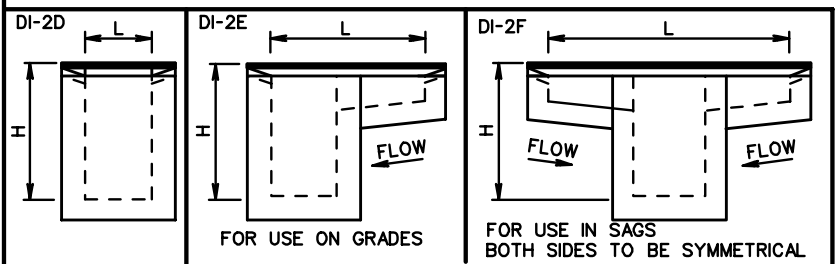

SPECIFICATION REFERENCE
 233
 302

STANDARD CURB DROP INLET
 30" - 48" PIPE: MAXIMUM DEPTH (H) = 9"
 VIRGINIA DEPARTMENT OF TRANSPORTATION

VDOT
 ROAD AND BRIDGE STANDARDS
 REVISION DATE SHEET 1 OF 2
 104.06

TABLE OF QUANTITIES

TYPE	L	CONCRETE		REINFORCING STEEL														WEIGHT					
				BARS A		BARS A-1		BARS B		BARS B-1		BARS D		BARS D-1		BARS E			BARS F		BARS L		BARS M
		Ft.	Cu. Yds.	No.	Lin. Ft.*	No.	Lin. Ft.*	No.	Lin. Ft.*	No.	Lin. Ft. *	No.	Lin. Ft. *	No.	Lin. Ft.*	No.	Lin. Ft.*		No.	Lin. Ft.*	No.	Lin. Ft.*	No.
DI-2D	4'-8"	4.52	1	5'-8"	5	5'-8"	7	3'-2"	-	-	13	6'-8"	13	5'-8"	-	-	-	-	12	5'-8"	13	1'-0"	328
DI-2E	6'-0"	4.73	1	5'-8"	5	7'-0"	7	3'-2"	3	4'-3" to 4'-6"	13	6'-8"	13	5'-8"	3	1'-0"	3	1'-6"	12	5'-8"	13	1'-0"	350
	8'-0"	5.05	1	5'-8"	5	9'-0"	7	3'-2"	7	4'-3" to 4'-6"	13	6'-8"	13	5'-8"	3	3'-0"	3	1'-6"	12	5'-8"	13	1'-0"	371
	10'-0"	5.36	1	5'-8"	5	11'-0"	7	3'-2"	10	4'-3" to 4'-6"	13	6'-8"	13	5'-8"	3	5'-0"	3	1'-6"	12	5'-8"	13	1'-0"	406
	12'-0"	5.68	1	5'-8"	5	13'-0"	7	3'-2"	15	4'-3" to 4'-6"	13	6'-8"	13	5'-8"	3	7'-0"	3	1'-6"	12	5'-8"	13	1'-0"	441
	14'-0"	6.00	1	5'-8"	5	15'-0"	7	3'-2"	19	4'-3" to 4'-6"	13	6'-8"	13	5'-8"	3	9'-0"	3	1'-6"	12	5'-8"	13	1'-0"	476
	16'-0"	6.31	1	5'-8"	5	17'-0"	7	3'-2"	23	4'-3" to 4'-6"	13	6'-8"	13	5'-8"	3	11'-0"	3	1'-6"	12	5'-8"	13	1'-0"	511
	18'-0"	6.62	1	5'-8"	5	19'-0"	7	3'-2"	27	4'-3" to 4'-6"	13	6'-8"	13	5'-8"	3	13'-0"	3	1'-6"	12	5'-8"	13	1'-0"	546
	20'-0"	6.94	1	5'-8"	5	21'-0"	7	3'-2"	31	4'-3" to 4'-6"	13	6'-8"	13	5'-8"	3	15'-0"	3	1'-6"	12	5'-8"	13	1'-0"	581
	DI-2F	6'-0"	4.73	1	5'-8"	5	7'-0"	7	3'-2"	2	4'-3" to 4'-6"	13	6'-8"	13	5'-8"	6	1'-0"	6	1'-6"	12	5'-8"	13	1'-0"
8'-0"		5.05	1	5'-8"	5	9'-0"	7	3'-2"	6	4'-3" to 4'-6"	13	6'-8"	13	5'-8"	6	2'-0"	6	1'-6"	12	5'-8"	13	1'-0"	388
10'-0"		5.36	1	5'-8"	5	11'-0"	7	3'-2"	10	4'-3" to 4'-6"	13	6'-8"	13	5'-8"	6	3'-0"	6	1'-6"	12	5'-8"	13	1'-0"	423
12'-0"		5.68	1	5'-8"	5	13'-0"	7	3'-2"	14	4'-3" to 4'-6"	13	6'-8"	13	5'-8"	6	4'-0"	6	1'-6"	12	5'-8"	13	1'-0"	458
14'-0"		6.00	1	5'-8"	5	15'-0"	7	3'-2"	18	4'-3" to 4'-6"	13	6'-8"	13	5'-8"	6	5'-0"	6	1'-6"	12	5'-8"	13	1'-0"	493
16'-0"		6.31	1	5'-8"	5	17'-0"	7	3'-2"	22	4'-3" to 4'-6"	13	6'-8"	13	5'-8"	6	6'-0"	6	1'-6"	12	5'-8"	13	1'-0"	528
18'-0"		6.62	1	5'-8"	5	19'-0"	7	3'-2"	26	4'-3" to 4'-6"	13	6'-8"	13	5'-8"	6	7'-0"	6	1'-6"	12	5'-8"	13	1'-0"	563
20'-0"		6.94	1	5'-8"	5	21'-0"	7	3'-2"	30	4'-3" to 4'-6"	13	6'-8"	13	5'-8"	6	8'-0"	6	1'-6"	12	5'-8"	13	1'-0"	598

NOTES

- DEPTH OF INLET (H) TO BE SHOWN ON PLANS.
- THE "H" DIMENSION SHOWN ON THE STANDARDS AND SPECIFIED ON THE PLANS WILL BE MEASURED FROM THE INVERT OF THE OUTFALL PIPE TO THE TOP OF THE STRUCTURE. PLAN "H" DIMENSIONS ARE APPROXIMATE ONLY FOR ESTIMATING PURPOSES AND THE ACTUAL DIMENSIONS SHALL BE DETERMINED BY THE CONTRACTOR FROM FIELD CONDITIONS.
- WHEN SPECIFIED ON THE PLANS THE INVERT IS TO BE SHAPED IN ACCORDANCE WITH STANDARD IS-1. THE COST OF FURNISHING AND PLACING ALL MATERIALS INCIDENTAL TO THE SHAPING IS TO BE INCLUDED IN THE BID PRICE FOR THE STRUCTURE.
- IN THE EVENT THE INVERT OF THE OUTFALL PIPE IS HIGHER THAN THE BOTTOM OF THE STRUCTURE, THE INVERT OF THE STRUCTURE SHALL BE SHAPED WITH CEMENT MORTAR TO PREVENT STANDING OR PONDING OF WATER IN THE STRUCTURE. THE COST OF FURNISHING AND PLACING ALL MATERIALS INCIDENTAL TO THE SHAPING IS TO BE INCLUDED IN THE BID PRICE FOR THE STRUCTURE.
- STEPS ARE TO BE PROVIDED WHEN H IS 4'-0" OR GREATER. FOR DETAILS SEE STANDARD ST-1.
- THIS ITEM MAY BE PRECAST OR CAST-IN-PLACE.
- #4 X 8" SMOOTH DOWELS AT APPROXIMATELY 12" C-C TO BE PLACED IN ALL AREAS ADJACENT TO ABUTTING CONCRETE TO PREVENT SETTLEMENT. IN LIEU OF DOWELS A 2" X 4" NOTCH MAY BE PROVIDED. SEE STANDARD T-DI-3, 4 FOR ALTERNATE DESIGN.
- 3" DIAMETER WEEP HOLE TO BE LOCATED TO DRAIN SUBBASE MATERIAL. WEEP HOLE WITH 12"X12" PLASTIC HARDWARE CLOTH 1/4" MESH OR GALVANIZED STEEL WIRE, MINIMUM WIRE DIAMETER 0.03", NUMBER 4 MESH HARDWARE CLOTH ANCHORED FIRMLY TO THE OUTSIDE OF THE STRUCTURE.
- ALL REINFORCING STEEL SHALL HAVE A MIN. COVER OF 2".
- ALL REINFORCING STEEL TO BE CUT CLEAR OF ALL OPENINGS BY 2".
- CAST-IN PLACE CONCRETE IS TO BE CLASS A3 (3000 PSI). PRECAST CONCRETE IS TO BE 4000 PSI.
- LENGTH OF SLOT (L) WILL, IN EVERY CASE, BE SHOWN ON PLANS.
- THIS STANDARD IS INTENDED FOR USE IN CURB AND GUTTER SITUATIONS ONLY.
- STANDARD INLETS MAY BE CONSTRUCTED WITH CONCRETE BLOCKS IN ACCORDANCE WITH THE DETAILS SHOWN ON STANDARD DRAWING DI-MB.
- THIS AREA MAY BE EARTHEN, IN WHICH CASE THE EXPANSION JOINTS WILL APPLY ONLY TO CURB AND GUTTER.
- CONCRETE QUANTITIES SHOWN ARE FOR DEPTH (H) OF 5'-0" WITHOUT PIPES. THE AMOUNT DISPLACED BY PIPES MUST BE DEDUCTED TO OBTAIN TRUE QUANTITIES. FOR INLETS OF DIFFERENT DEPTHS ADD OR SUBTRACT 0.63 CUBIC YARDS OF CONCRETE FOR EACH FOOT OF DEPTH.
- LENGTH OF ANGLE IRON AS SHOWN ON SHEET 1 OF 2 IS TO BE L + 16" AT 4.10 LBS./FT..
- *DENOTES LENGTH OF ONE (1) BAR.
- ALL REINFORCING BARS TO BE #5.
- GRATE TO BE INSTALLED SO SLOTS WILL DIRECT WATER TOWARD THE INLET THROAT. GRATE MUST BE REVERSIBLE (RIGHT HAND GRATE IS SHOWN).
- MINIMUM HEIGHT WHEN PIPES ARE LOCATED UNDER EXTENDED SLOT OF INLET.
- INLET MAY BE USED WITH LARGER LONGITUDINAL PIPES (72" MAXIMUM) PROVIDED HORIZONTAL CLEARANCE BETWEEN ADJACENT PIPES IS ADEQUATE AND MINIMUM HEIGHT (H) EQUALS PIPE DIAMETER PLUS 2'-10".



ROAD AND BRIDGE STANDARDS

SHEET 2 OF 2

REVISION DATE

104.07

STANDARD CURB DROP INLET

30" - 48" PIPE: MAXIMUM DEPTH (H) - 9'

VIRGINIA DEPARTMENT OF TRANSPORTATION

SPECIFICATION
REFERENCE233
302

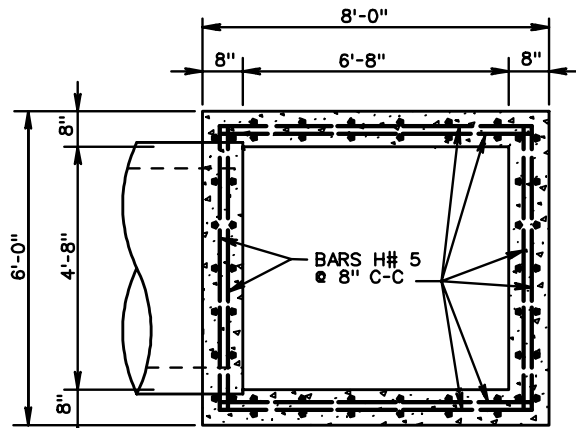

SECTION A-A

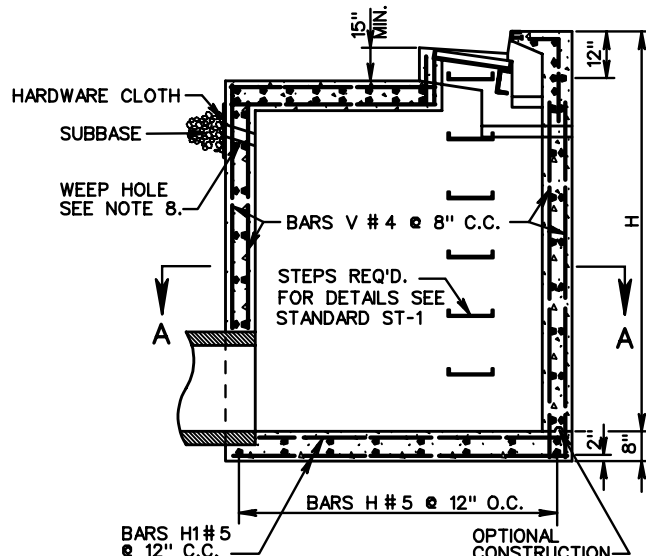

SECTION THROUGH ELEVATION

SCHEDULE OF REINFORCING STEEL		
BARS MARK	NO. REQUIRED	LENGTH
H	4(1.5H+1)+16	5'-8"
H1	4(1.5H+1)+12	7'-8"
V	76	H-1'-2"

- NOTES**
- DEPTH OF INLET (H) TO BE SHOWN ON PLANS.
 - THE "H" DIMENSION SHOWN ON THE STANDARDS AND SPECIFIED ON THE PLANS WILL BE MEASURED FROM THE INVERT OF THE OUTFALL PIPE TO THE TOP OF THE STRUCTURE. PLAN "H" DIMENSIONS ARE APPROXIMATE ONLY FOR ESTIMATING PURPOSES AND THE ACTUAL DIMENSIONS SHALL BE DETERMINED BY THE CONTRACTOR FROM FIELD CONDITIONS.
 - WHEN SPECIFIED ON THE PLANS THE INVERT IS TO BE SHAPED IN ACCORDANCE WITH STANDARD IS-1. THE COST OF FURNISHING AND PLACING ALL MATERIALS INCIDENTAL TO THE SHAPING IS TO BE INCLUDED IN THE BID PRICE FOR THE STRUCTURE.
 - IN THE EVENT THE INVERT OF THE OUTFALL PIPE IS HIGHER THAN THE BOTTOM OF THE STRUCTURE, THE INVERT OF THE STRUCTURE SHALL BE SHAPED WITH CEMENT MORTAR TO PREVENT STANDING OR PONDING OF WATER IN THE STRUCTURE. THE COST OF FURNISHING AND PLACING ALL MATERIALS INCIDENTAL TO THE SHAPING IS TO BE INCLUDED IN THE BID PRICE FOR THE STRUCTURE.
 - STEPS ARE TO BE PROVIDED WHEN H IS 4'-0" OR GREATER. FOR DETAILS SEE STANDARD ST-1.
 - THIS ITEM MAY BE PRECAST OR CAST-IN-PLACE.
 - # 4 X 8" SMOOTH DOWELS AT APPROXIMATELY 12" C-C TO BE PLACED IN ALL AREAS ADJACENT TO ABUTTING CONCRETE TO PREVENT SETTLEMENT. IN LIEU OF DOWELS A 2" X 4" NOTCH MAY BE PROVIDED. SEE STANDARD T-DI-3, 4 FOR ALTERNATE DESIGN.
 - 3" DIAMETER WEEP HOLE TO BE LOCATED TO DRAIN SUBBASE MATERIAL. WEEP HOLE WITH 12"X12" PLASTIC HARDWARE CLOTH 1/4" MESH OR GALVANIZED STEEL WIRE, MINIMUM WIRE DIAMETER 0.03", NUMBER 4 MESH HARDWARE CLOTH ANCHORED FIRMLY TO THE OUTSIDE OF THE STRUCTURE.
 - ALL REINFORCING STEEL SHALL HAVE A MIN. COVER OF 2".
 - ALL REINFORCING STEEL TO BE CUT CLEAR OF ALL OPENINGS BY 2".
 - CAST-IN PLACE CONCRETE IS TO BE CLASS A3 (3000 PSI). PRECAST CONCRETE IS TO BE 4000 PSI.
 - LENGTH OF SLOT (L) WILL, IN EVERY CASE, BE SHOWN ON PLANS.
 - THIS STANDARD IS INTENDED FOR USE IN CURB AND GUTTER SITUATIONS ONLY.
 - IF OPTIONAL CONSTRUCTION JOINT IS USED IT IS TO BE KEYS. ALL SPLICES IN BARS V TO BE A MINIMUM OF 40D (20").
 - FOR PLAN VIEW OF INLET SEE STANDARD DI-2D, 2E, 2F.
 - PROVIDE SAFETY SLABS WHEN SPECIFIED ON THE PLANS.
 - FOR DESCRIPTION AND LOCATION OF DIMENSION L SEE SHEET 104.06.
 - FOR NUMBER OF BARS A-M REQUIRED AND LENGTHS SEE SHEET 104.07.
 - QUANTITIES SHOWN ARE FOR MIN. INLETS OF EACH TYPE. FOR INLETS OF GREATER DEPTH (H) OR LARGER SLOTS (L), INCREMENTS SHOWN PER FOOT MUST BE ADDED. THE AMOUNT OF CONCRETE AND STEEL DISPLACED MUST BE DEDUCTED TO OBTAIN TRUE QUANTITIES.
 - FOR DETAILS AND DIMENSIONS OF CURB, SLOT, BEAM, COLLAR AND GRATE, DROPPED GUTTER LINE, AND REINFORCING AND STRUCTURAL STEEL NOT DETAILED SEE STANDARD DI-2D.
 - INLET MAY BE USED WITH LARGER LONGITUDINAL PIPE (72" MAXIMUM) PROVIDED HORIZONTAL CLEARANCE BETWEEN ADJACENT PIPES IS ADEQUATE.

APPROXIMATE QUANTITIES FOR MINIMUM 9' DEPTH INLET			
DI-TYPE	DIMENSION L SEE NOTE 17 Lin. Ft.	REINFORCING STEEL Lbs.	CONCRETE Cu. Yds.
2DD	4'-8"	1,683	6.93
2EE	6'-0"	1,714	7.20
2FF	6'-0"	1,733	7.25

INCREMENTS TO BE ADDED FOR EACH ADDITIONAL FOOT OF DEPTH (H) AND OR SLOT LENGTH (L)				
DI-TYPE	H		L	
	CONCRETE	STEEL	CONCRETE	STEEL
	Cu. Yds.	Lbs.	Cu. Yds.	Lbs.
2DD	0.63	191	—	—
2EE	0.63	191	0.16	17
2FF	0.63	191	0.16	17

SPECIFICATION REFERENCE
233
302

STANDARD CURB DROP INLET
 30" - 48" PIPE: DEPTH (H) = 9' TO 20'
 VIRGINIA DEPARTMENT OF TRANSPORTATION

VDOT ROAD AND BRIDGE STANDARDS	
REVISION DATE	SHEET 1 OF 1
104.08	

DI-3A, 3B, 3C

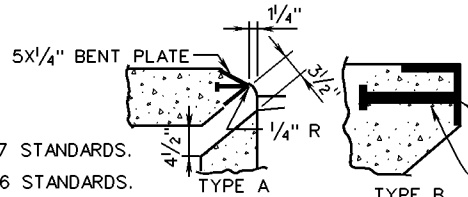
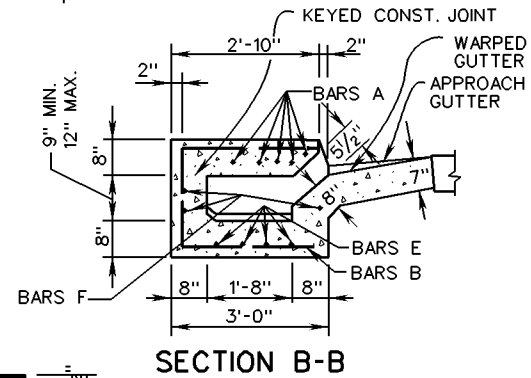
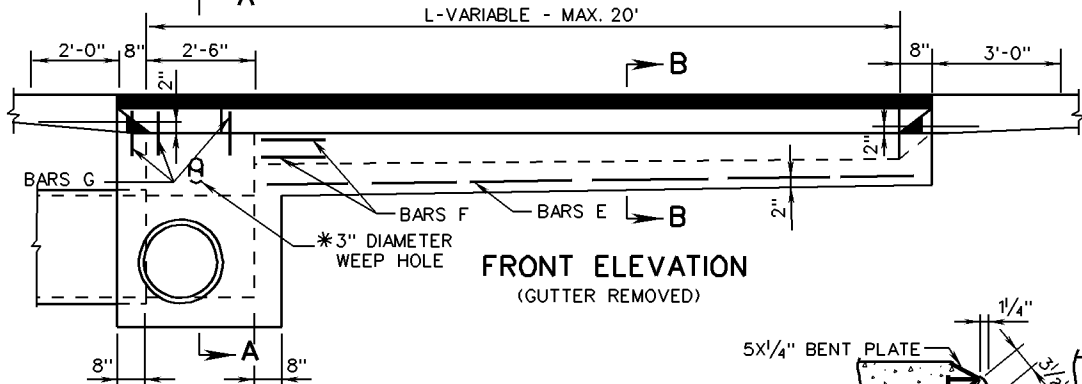
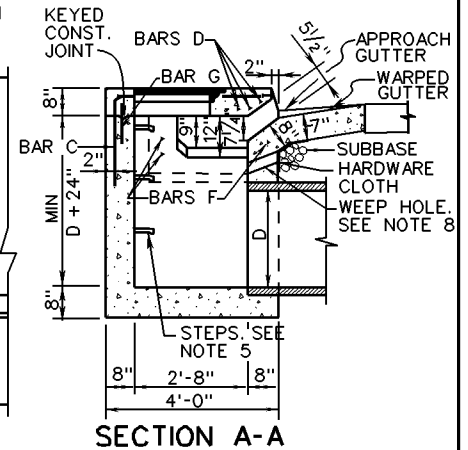
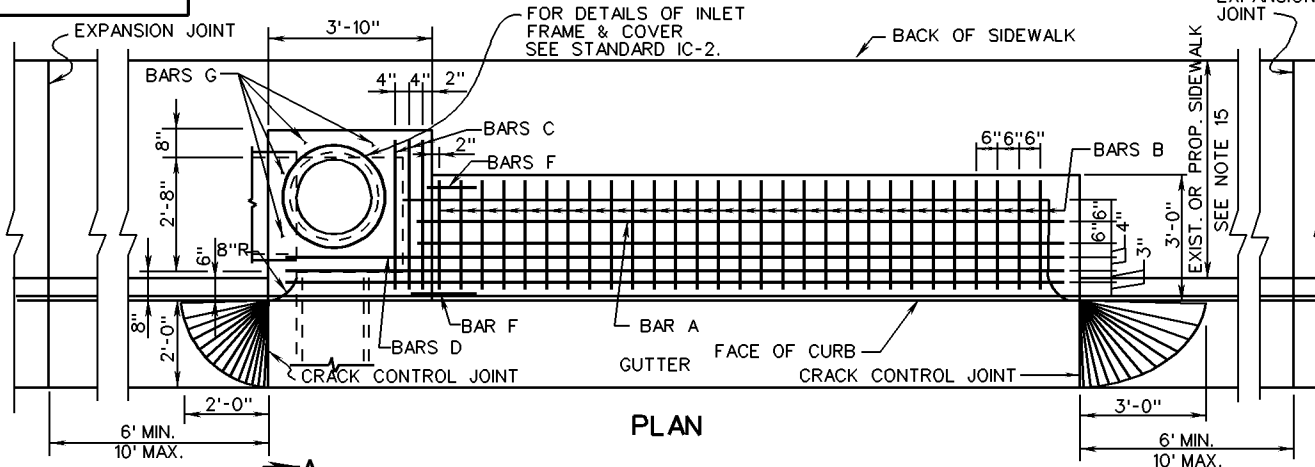

TYPE A NOSE DETAIL SHALL BE USED WITH CG-3 & CG-7 STANDARDS.
 TYPE B NOSE DETAIL SHALL BE USED WITH CG-2 & CG-6 STANDARDS.
 GALVANIZED PLATE FOR TYPE A TO BE BENT ON AN ANGLE OF 68° 30' CONNECTORS AND IS TO BE ANCHORED WITH 1/2" X 4" STUD SHEAR WELDED TO BENT PLATE AT 2' C-C.

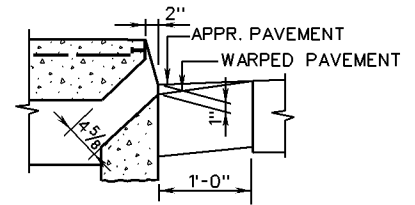
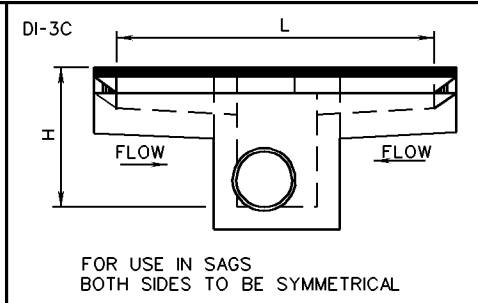
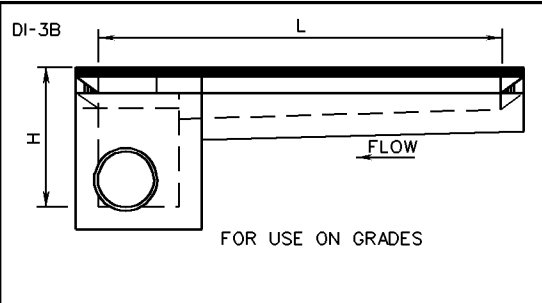
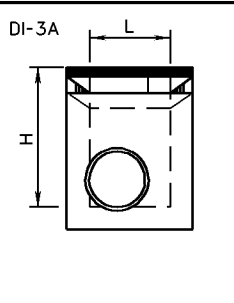

VDOT	
ROAD AND BRIDGE STANDARDS	
SHEET 1 OF 2	REVISION DATE
104.09	08/10

STANDARD CURB DROP INLET
 12" - 30" PIPE: MAXIMUM DEPTH (H) - 8'
 VIRGINIA DEPARTMENT OF TRANSPORTATION

SPECIFICATION REFERENCE
233 302

TABLE OF QUANTITIES

DI-3A, 3B, 3C

TYPE	L	AREA OF SLOT		REINFORCING STEEL														WEIGHT
				Concrete		BARS A		BARS B		BARS C		BARS D		BARS E		BARS F		
		Ft.	Sq. Ft.	Cu. Yds.	No.	Lin. Ft. *	No.	Lin. Ft. *	No.	Lin. Ft. *	No.	Lin. Ft.*	No.	Lin. Ft.*	No.	Lin. Ft.*	No.	
DI-3A	2'-6"	1.15	2.26	-	-	-	-	1	5'-7"	3	3'-2"	-	-	-	-	6	1'-0"	22
DI-3B	4'	1.83	2.59	5	1'-6"	2	6'-7" to 6'-10"	3	5'-7"	3	3'-2"	4	1'-6"	3	1'-6"	4	1'-0"	64
	6'	2.75	3.02	5	3'-6"	6	6'-7" to 6'-10"	3	5'-7"	3	3'-2"	4	3'-6"	3	1'-6"	4	1'-0"	111
	8'	3.67	3.46	5	5'-6"	10	6'-7" to 6'-10"	3	5'-7"	3	3'-2"	4	5'-6"	3	1'-6"	4	1'-0"	158
	10'	4.58	3.90	5	7'-6"	14	6'-7" to 6'-10"	3	5'-7"	3	3'-2"	4	7'-6"	3	1'-6"	4	1'-0"	204
	12'	5.50	4.34	5	9'-6"	18	6'-7" to 6'-10"	3	5'-7"	3	3'-2"	4	9'-6"	3	1'-6"	4	1'-0"	251
	14'	6.42	4.78	5	11'-6"	22	6'-7" to 6'-10"	3	5'-7"	3	3'-2"	4	11'-6"	3	1'-6"	4	1'-0"	298
	16'	7.33	5.22	5	13'-6"	26	6'-7" to 6'-10"	3	5'-7"	3	3'-2"	4	13'-6"	3	1'-6"	4	1'-0"	345
	18'	8.25	5.66	5	15'-6"	30	6'-7" to 6'-10"	3	5'-7"	3	3'-2"	4	15'-6"	3	1'-6"	4	1'-0"	391
	20'	9.17	6.09	5	17'-6"	34	6'-7" to 6'-10"	3	5'-7"	3	3'-2"	4	17'-6"	3	1'-6"	4	1'-0"	438
	DI-3C	6'	2.75	3.01	10	1'-9"	4	6'-7" to 6'-10"	5	5'-7"	3	3'-2"	8	1'-9"	6	1'-6"	2	1'-0"
8'		3.67	3.45	10	2'-9"	8	6'-7" to 6'-10"	5	5'-7"	3	3'-2"	8	2'-9"	6	1'-6"	2	1'-0"	158
10'		4.58	3.89	10	3'-9"	12	6'-7" to 6'-10"	5	5'-7"	3	3'-2"	8	3'-9"	6	1'-6"	2	1'-0"	205
12'		5.50	4.33	10	4'-9"	16	6'-7" to 6'-10"	5	5'-7"	3	3'-2"	8	4'-9"	6	1'-6"	2	1'-0"	252
14'		6.42	4.77	10	5'-9"	20	6'-7" to 6'-10"	5	5'-7"	3	3'-2"	8	5'-9"	6	1'-6"	2	1'-0"	298
16'		7.33	5.21	10	6'-9"	24	6'-7" to 6'-10"	5	5'-7"	3	3'-2"	8	6'-9"	6	1'-6"	2	1'-0"	345
18'		8.25	5.65	10	7'-9"	28	6'-7" to 6'-10"	5	5'-7"	3	3'-2"	8	7'-9"	6	1'-6"	2	1'-0"	392
20'		9.17	6.09	10	8'-9"	32	6'-7" to 6'-10"	5	5'-7"	3	3'-2"	8	8'-9"	6	1'-6"	2	1'-0"	439

NOTES

1. DEPTH OF INLET (H) TO BE SHOWN ON PLANS.
2. THE "H" DIMENSION SHOWN ON THE STANDARDS AND SPECIFIED ON THE PLANS WILL BE MEASURED FROM THE INVERT OF THE OUTFALL PIPE TO THE TOP OF THE STRUCTURE. PLAN "H" DIMENSIONS ARE APPROXIMATE ONLY FOR ESTIMATING PURPOSES AND THE ACTUAL DIMENSIONS SHALL BE DETERMINED BY THE CONTRACTOR FROM FIELD CONDITIONS.
3. WHEN SPECIFIED ON THE PLANS THE INVERT IS TO BE SHAPED IN ACCORDANCE WITH STANDARD IS-1. THE COST OF FURNISHING AND PLACING ALL MATERIALS INCIDENTAL TO THE SHAPING IS TO BE INCLUDED IN THE BID PRICE FOR THE STRUCTURE.
4. IN THE EVENT THE INVERT OF THE OUTFALL PIPE IS HIGHER THAN THE BOTTOM OF THE STRUCTURE, THE INVERT OF THE STRUCTURE SHALL BE SHAPED WITH CEMENT MORTAR TO PREVENT STANDING OR PONDING OF WATER IN THE STRUCTURE. THE COST OF FURNISHING AND PLACING ALL MATERIALS INCIDENTAL TO THE SHAPING IS TO BE INCLUDED IN THE BID PRICE FOR THE STRUCTURE.
5. STEPS ARE TO BE PROVIDED WHEN H IS 4'-0" OR GREATER. FOR DETAILS SEE STANDARD ST-1.
6. THIS ITEM MAY BE PRECAST OR CAST-IN-PLACE.
7. #4 X 8" SMOOTH DOWELS AT APPROXIMATELY 12" C-C TO BE PLACED IN ALL AREAS ADJACENT TO ABUTTING CONCRETE TO PREVENT SETTLEMENT.
8. 3" DIAMETER WEEP HOLE TO BE LOCATED TO DRAIN SUBBASE MATERIAL. WEEP HOLE WITH 12"X12" PLASTIC HARDWARE CLOTH 1/4" MESH OR GALVANIZED STEEL WIRE, MINIMUM WIRE DIAMETER 0.03", NUMBER 4 MESH HARDWARE CLOTH ANCHORED FIRMLY TO THE OUTSIDE OF THE STRUCTURE.
9. ALL REINFORCING STEEL SHALL HAVE A MIN. COVER OF 2".
10. ALL REINFORCING STEEL TO BE CUT CLEAR OF ALL OPENINGS BY 2".
11. CAST-IN PLACE CONCRETE IS TO BE CLASS A3 (3000 PSI). PRECAST CONCRETE IS TO BE 4000 PSI.
12. LENGTH OF SLOT (L) WILL, IN EVERY CASE, BE SHOWN ON PLANS.
13. IF INLET IS CONSTRUCTED IN MEDIAN CURB OR WITH INTEGRAL CURB, GUTTER IS TO BE OMITTED (SEE DETAIL).
14. STANDARD INLETS MAY BE CONSTRUCTED WITH CONCRETE BLOCKS IN ACCORDANCE WITH THE DETAILS SHOWN ON STANDARD DRAWING DI-MB.
15. THIS AREA MAY BE EARTHEN, IN WHICH CASE THE EXPANSION JOINTS WILL APPLY ONLY TO CURB AND GUTTER.
16. CONCRETE QUANTITIES SHOWN ARE FOR DEPTH (H) OF 5'-2" WITHOUT PIPES. THE AMOUNT DISPLACED BY PIPES MUST BE DEDUCTED TO OBTAIN TRUE QUANTITIES. FOR INLETS OF DIFFERENT DEPTHS ADD OR SUBTRACT 0.32 CUBIC YARDS OF CONCRETE FOR EACH FOOT OF DEPTH.
17. LENGTH OF ANGLE IRON AS SHOWN ON SHEET 1 OF 2 IS TO BE L +16" AT 4.10 LBS./FT..
18. * DENOTES LENGTH OF ONE (1) BAR.
19. ALL REINFORCING BARS TO BE #5.
20. WHEN INLET IS USED IN 4'-0" MEDIAN, BACK OF INLET IS TO BE SHAPED TO CONFORM TO PROPOSED CURB.

SPECIFICATION REFERENCE

233
302

STANDARD CURB DROP INLET

12" - 30" PIPE: MAXIMUM DEPTH (H) = 8'

VIRGINIA DEPARTMENT OF TRANSPORTATION

VDOT

ROAD AND BRIDGE STANDARDS

REVISION DATE

SHEET 2 OF 2

104.10

NOTES

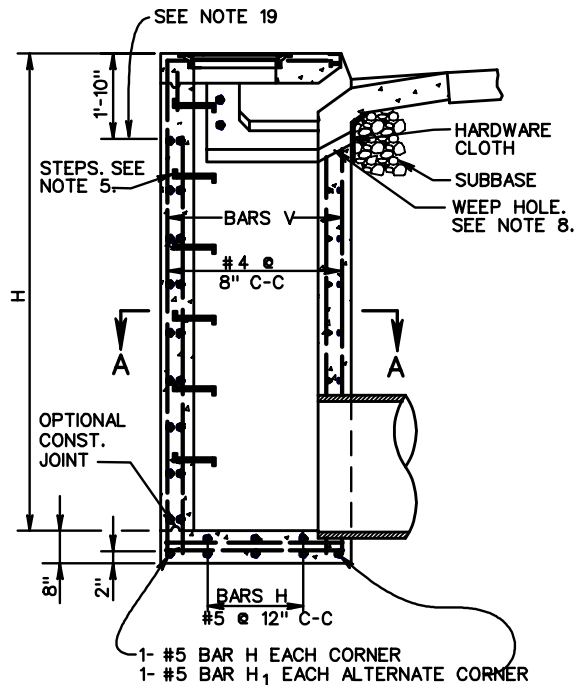
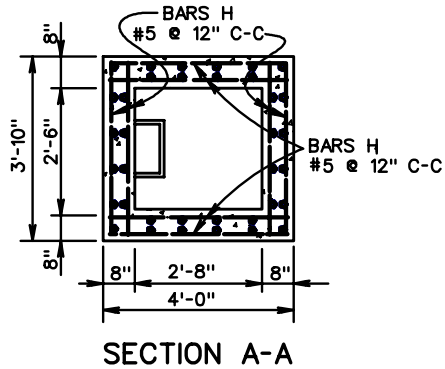

- DEPTH OF INLET (H) TO BE SHOWN ON PLANS. MINIMUM DEPTH (H) TO BE 8'-0". MAXIMUM DEPTH TO BE 20'-0". FOR INLETS LESS THAN 8' USE STANDARD DI-3A, 3B, 3C.
- THE "H" DIMENSION SHOWN ON THE STANDARDS AND SPECIFIED ON THE PLANS WILL BE MEASURED FROM THE INVERT OF THE OUTFALL PIPE TO THE TOP OF THE STRUCTURE. PLAN "H" DIMENSIONS ARE APPROXIMATE ONLY FOR ESTIMATING PURPOSES AND THE ACTUAL DIMENSIONS SHALL BE DETERMINED BY THE CONTRACTOR FROM FIELD CONDITIONS.
- WHEN SPECIFIED ON THE PLANS THE INVERT IS TO BE SHAPED IN ACCORDANCE WITH STANDARD IS-1. THE COST OF FURNISHING AND PLACING ALL MATERIALS INCIDENTAL TO THE SHAPING IS TO BE INCLUDED IN THE BID PRICE FOR THE STRUCTURE.
- IN THE EVENT THE INVERT OF THE OUTFALL PIPE IS HIGHER THAN THE BOTTOM OF THE STRUCTURE, THE INVERT OF THE STRUCTURE SHALL BE SHAPED WITH CEMENT MORTAR TO PREVENT STANDING OR PONDING OF WATER IN THE STRUCTURE. THE COST OF FURNISHING AND PLACING ALL MATERIALS INCIDENTAL TO THE SHAPING IS TO BE INCLUDED IN THE BID PRICE FOR THE STRUCTURE.
- STEPS ARE REQUIRED. FOR DETAILS SEE STANDARD ST-1.
- THIS ITEM MAY BE PRECAST OR CAST-IN-PLACE.
- # 4 X 8" SMOOTH DOWELS AT APPROXIMATELY 12" C-C TO BE PLACED IN ALL AREAS ADJACENT TO ABUTTING CONCRETE TO PREVENT SETTLEMENT. IN LIEU OF DOWELS A 2" X 4" NOTCH MAY BE PROVIDED. SEE STANDARD T-DI-3, 4 FOR ALTERNATE DESIGN.
- 3" DIAMETER WEEP HOLE TO BE LOCATED TO DRAIN SUBBASE MATERIAL. WEEP HOLE WITH 12"X12" PLASTIC HARDWARE CLOTH 1/4" MESH OR GALVANIZED STEEL WIRE, MINIMUM WIRE DIAMETER 0.03", NUMBER 4 MESH HARDWARE CLOTH ANCHORED FIRMLY TO THE OUTSIDE OF THE STRUCTURE.
- ALL REINFORCING STEEL SHALL HAVE A MIN. COVER OF 2".
- ALL REINFORCING STEEL TO BE CUT CLEAR OF ALL OPENINGS BY 2".
- CAST-IN PLACE CONCRETE IS TO BE CLASS A3 (3000 PSI). PRECAST CONCRETE IS TO BE 4000 PSI.
- LENGTH OF SLOT (L) WILL, IN EVERY CASE, BE SHOWN ON PLANS.
- WHEN INLET IS USED IN 4' MEDIAN BACK OF INLET IS TO BE SHAPED TO CONFORM WITH PROPOSED CURB.
- IF OPTIONAL CONSTRUCTION JOINT IS USED IT IS TO BE KEYS. ALL SPLICES IN BARS V TO BE A MINIMUM OF 40 DIAMETERS (20").
- FOR PLAN VIEW OF INLET SEE STANDARD DI-3A, 3B, 3C.
- QUANTITIES SHOWN ARE FOR MINIMUM INLETS OF EACH TYPE. FOR INLETS OF GREATER DEPTH (H) OR LONGER SLOT (L) INCREMENTS SHOWN PER FOOT MUST BE ADDED. THE AMOUNT OF CONCRETE AND STEEL DISPLACED BY PIPES MUST BE DEDUCTED TO OBTAIN TRUE QUANTITIES.
- FOR NUMBER OF BARS A-G REQUIRED AND LENGTHS SEE SHEET 104.10.
- FOR DESCRIPTION AND LOCATION OF DIMENSION L SEE SHEET 104.09.
- FOR ALL DETAILS, DIMENSIONS, AND REINFORCING STEEL ABOVE THIS LINE SEE STANDARD DI-3A, 3B, 3C.

SCHEDULE OF REINFORCING STEEL					
BARS H		BARS H ₁		BARS V	
NO. REQ'D.	LENGTH	NO. REQ'D.	LENGTH	NO. REQ'D.	LENGTH
4x(H+1)	3'-6"	4x(H+1)	3'-8"	36	H-1'-4"

APPROXIMATE QUANTITIES FOR MINIMUM 8' DEPTH INLET			
TYPE	DIMENSION L SEE NOTE 18	REINFORCING STEEL	CONCRETE
	Lin. Ft.	Lbs.	Cu. Yds.
3AA	2'-6"	452	3.14
3BB	4'-0"	494	3.47
3CC	6'-0"	541	3.89

INCREMENTS TO BE ADDED FOR EACH ADDITIONAL FOOT OF DEPTH (H) AND/OR SLOT LENGTH (L)			
H		L	
CONCRETE	STEEL	CONCRETE	STEEL
Cu. Yds.	Lbs.	Cu. Yds.	Lbs.
0.317	54	-	-
0.317	54	0.22	23.5
0.317	54	0.22	23.5

SECTION THROUGH ELEVATION



ROAD AND BRIDGE STANDARDS

SHEET 1 OF 1

REVISION DATE

104.11

STANDARD CURB DROP INLET

12" - 30" PIPE: DEPTH (H) 8' TO 20'

VIRGINIA DEPARTMENT OF TRANSPORTATION

SPECIFICATION REFERENCE

233
302

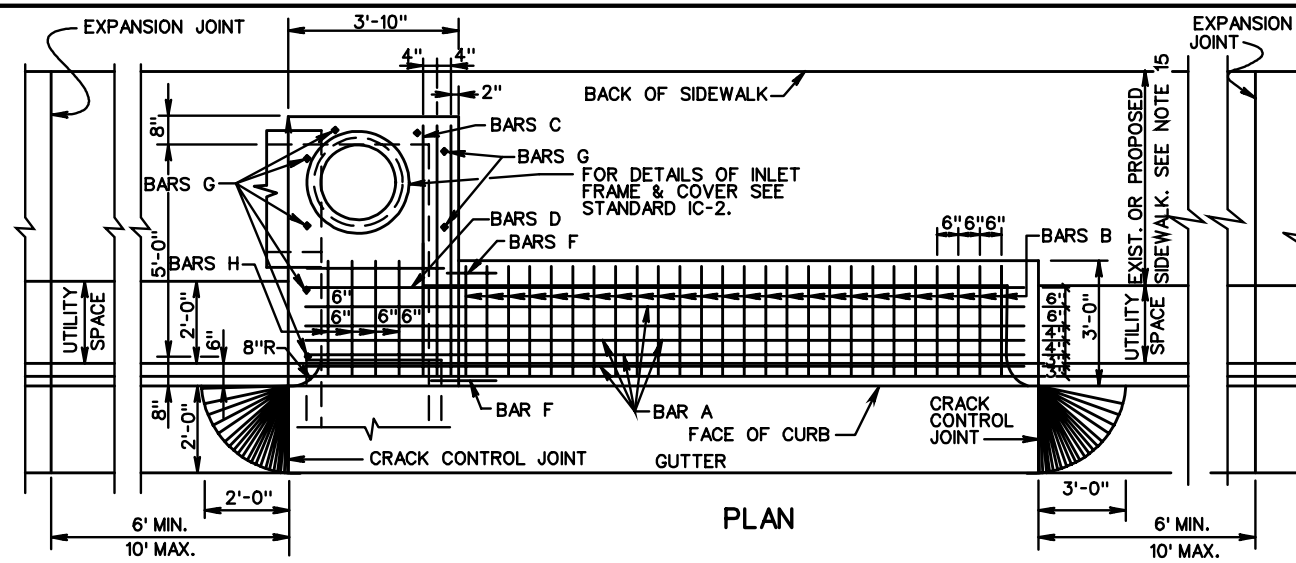

GALVANIZED PLATE FOR TYPE A TO BE BENT ON AN ANGLE OF 68° 30' AND IS TO BE ANCHORED WITH 1/2" X 4" STUD SHEAR CONNECTORS WELDED TO BENT PLATE AT 2" C-C.

TYPE A NOSE DETAIL SHALL BE USED WITH CG-3 AND CG-7 ST'D.

TYPE B NOSE DETAIL SHALL BE USED WITH CG-2 AND CG-6 ST'D.

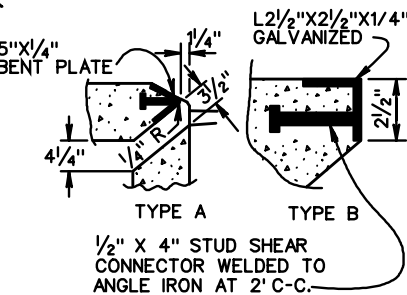

NOSE DETAILS

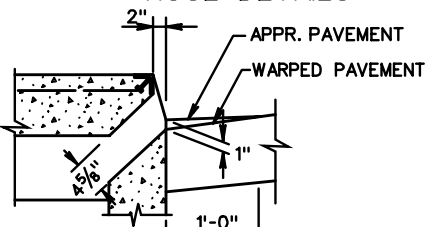

DETAIL WHEN USED ADJACENT TO CURB WITHOUT GUTTER

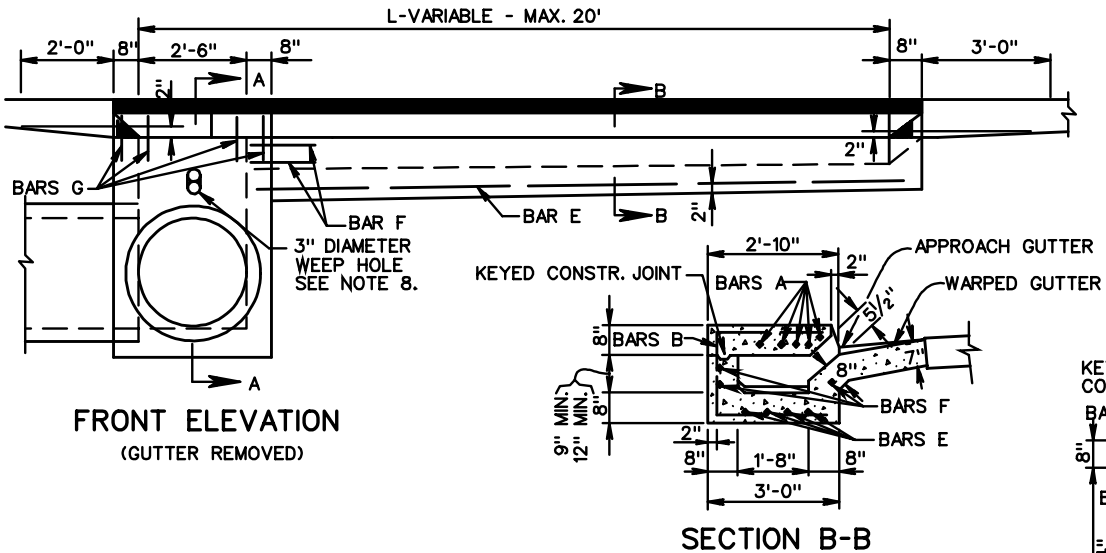

FRONT ELEVATION
(GUTTER REMOVED)

SECTION B-B

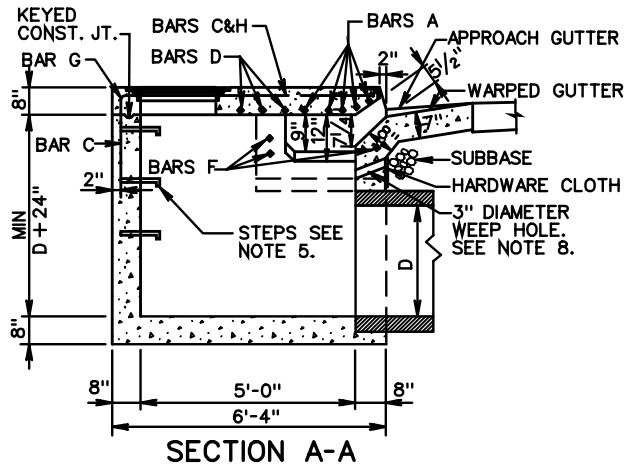

SECTION A-A

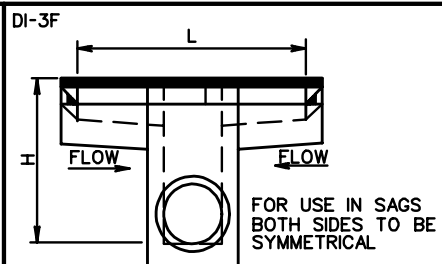
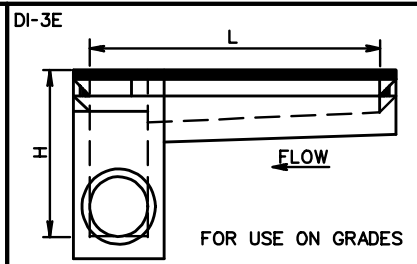
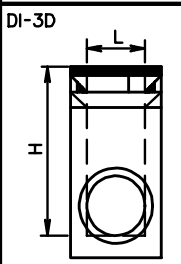

SPECIFICATION REFERENCE
233
302

STANDARD CURB DROP INLET (WITH UTILITY SPACE)

12" - 30" PIPE: MAXIMUM DEPTH (H) = 8'

VIRGINIA DEPARTMENT OF TRANSPORTATION



ROAD AND BRIDGE STANDARDS

REVISION DATE

SHEET 1 OF 2

104.12

TABLE OF QUANTITIES

TYPE	L	AREA OF SLOT	REINFORCING STEEL												WEIGHT					
			CONCRETE	BARS A		BARS B		BARS C		BARS D		BARS E		BARS F		BARS G		BARS H		
			Cu. Yds.	No.	Lin. Ft.*	No.	Lin. Ft.*	No.	Lin. Ft.*	No.	Lin. Ft.*	No.	Lin. Ft.*	No.		Lin. Ft.*	No.	Lin. Ft.*	No.	Lin. Ft.*
DI-3D	2'-6"	1.15	3.21	5	3'-2"	-	-	1	8'-0"	3	3'-2"	-	-	-	-	10	1'-0"	4	3'-1"	58
DI-3E	4'	1.83	3.54	5	4'-8"	2	6'-7" to 6'-10"	3	8'-0"	3	3'-2"	4	1'-6"	3	1'-6"	8	1'-0"	4	3'-1"	106
	6'	2.75	3.97	5	6'-8"	6	6'-7" to 6'-10"	3	8'-0"	3	3'-2"	4	3'-6"	3	1'-6"	8	1'-0"	4	3'-1"	153
	8'	3.67	4.41	5	8'-8"	10	6'-7" to 6'-10"	3	8'-0"	3	3'-2"	4	5'-6"	3	1'-6"	8	1'-0"	4	3'-1"	199
	10'	4.58	4.85	5	10'-8"	14	6'-7" to 6'-10"	3	8'-0"	3	3'-2"	4	7'-6"	3	1'-6"	8	1'-0"	4	3'-1"	246
	12'	5.50	5.29	5	12'-8"	18	6'-7" to 6'-10"	3	8'-0"	3	3'-2"	4	9'-6"	3	1'-6"	8	1'-0"	4	3'-1"	293
	14'	6.42	5.73	5	14'-8"	22	6'-7" to 6'-10"	3	8'-0"	3	3'-2"	4	11'-6"	3	1'-6"	8	1'-0"	4	3'-1"	340
	16'	7.33	6.17	5	16'-8"	26	6'-7" to 6'-10"	3	8'-0"	3	3'-2"	4	13'-6"	3	1'-6"	8	1'-0"	4	3'-1"	386
	18'	8.25	6.61	5	18'-8"	30	6'-7" to 6'-10"	3	8'-0"	3	3'-2"	4	15'-6"	3	1'-6"	8	1'-0"	4	3'-1"	433
20'	9.17	7.04	5	20'-8"	34	6'-7" to 6'-10"	3	8'-0"	3	3'-2"	4	17'-6"	3	1'-6"	8	1'-0"	4	3'-1"	480	
DI-3F	6'	2.75	3.96	5	6'-8"	4	6'-7" to 6'-10"	5	8'-0"	3	3'-2"	8	1'-9"	6	1'-6"	6	1'-0"	4	3'-1"	158
	8'	3.67	4.40	5	8'-8"	8	6'-7" to 6'-10"	5	8'-0"	3	3'-2"	8	2'-9"	6	1'-6"	6	1'-0"	4	3'-1"	205
	10'	4.58	4.84	5	10'-8"	12	6'-7" to 6'-10"	5	8'-0"	3	3'-2"	8	3'-9"	6	1'-6"	6	1'-0"	4	3'-1"	251
	12'	5.50	5.28	5	12'-8"	16	6'-7" to 6'-10"	5	8'-0"	3	3'-2"	8	4'-9"	6	1'-6"	6	1'-0"	4	3'-1"	298
	14'	6.42	5.72	5	14'-8"	20	6'-7" to 6'-10"	5	8'-0"	3	3'-2"	8	5'-9"	6	1'-6"	6	1'-0"	4	3'-1"	345
	16'	7.33	6.16	5	16'-8"	24	6'-7" to 6'-10"	5	8'-0"	3	3'-2"	8	6'-9"	6	1'-6"	6	1'-0"	4	3'-1"	392
	18'	8.25	6.60	5	18'-8"	28	6'-7" to 6'-10"	5	8'-0"	3	3'-2"	8	7'-9"	6	1'-6"	6	1'-0"	4	3'-1"	438
	20'	9.17	7.04	5	20'-8"	32	6'-7" to 6'-10"	5	8'-0"	3	3'-2"	8	8'-9"	6	1'-6"	6	1'-0"	4	3'-1"	485

NOTES

1. DEPTH OF INLET (H) TO BE SHOWN ON PLANS.
2. THE "H" DIMENSION SHOWN ON THE STANDARDS AND SPECIFIED ON THE PLANS WILL BE MEASURED FROM THE INVERT OF THE OUTFALL PIPE TO THE TOP OF THE STRUCTURE. PLAN "H" DIMENSIONS ARE APPROXIMATE ONLY FOR ESTIMATING PURPOSES AND THE ACTUAL DIMENSIONS SHALL BE DETERMINED BY THE CONTRACTOR FROM FIELD CONDITIONS.
3. WHEN SPECIFIED ON THE PLANS THE INVERT IS TO BE SHAPED IN ACCORDANCE WITH STANDARD IS-1. THE COST OF FURNISHING AND PLACING ALL MATERIALS INCIDENTAL TO THE SHAPING IS TO BE INCLUDED IN THE BID PRICE FOR THE STRUCTURE.
4. IN THE EVENT THE INVERT OF THE OUTFALL PIPE IS HIGHER THAN THE BOTTOM OF THE STRUCTURE, THE INVERT OF THE STRUCTURE SHALL BE SHAPED WITH CEMENT MORTAR TO PREVENT STANDING OR PONDING OF WATER IN THE STRUCTURE. THE COST OF FURNISHING AND PLACING ALL MATERIALS INCIDENTAL TO THE SHAPING IS TO BE INCLUDED IN THE BID PRICE FOR THE STRUCTURE.
5. STEPS ARE TO BE PROVIDED WHEN H IS 4'-0" OR GREATER. FOR DETAILS SEE STANDARD ST-1.
6. THIS ITEM MAY BE PRECAST OR CAST-IN-PLACE.
7. # 4 X 8" SMOOTH DOWELS AT APPROXIMATELY 12" C-C TO BE PLACED IN ALL AREAS ADJACENT TO ABUTTING CONCRETE TO PREVENT SETTLEMENT.
8. 3" DIAMETER WEEP HOLE TO BE LOCATED TO DRAIN SUBBASE MATERIAL. WEEP HOLE WITH 12"X12" PLASTIC HARDWARE CLOTH 1/4" MESH OR GALVANIZED STEEL WIRE, MINIMUM WIRE DIAMETER 0.03", NUMBER 4 MESH HARDWARE CLOTH ANCHORED FIRMLY TO THE OUTSIDE OF THE STRUCTURE.
9. ALL REINFORCING STEEL SHALL HAVE A MIN. COVER OF 2".
10. ALL REINFORCING STEEL TO BE CUT CLEAR OF ALL OPENINGS BY 2".
11. CAST-IN PLACE CONCRETE IS TO BE CLASS A3 (3000 PSI). PRECAST CONCRETE IS TO BE 4000 PSI.
12. LENGTH OF SLOT (L) WILL, IN EVERY CASE, BE SHOWN ON PLANS.
13. IF INLET IS CONSTRUCTED IN MEDIAN CURB OR WITH INTEGRAL CURB, GUTTER IS TO BE OMITTED (SEE DETAIL).
14. STANDARD INLETS MAY BE CONSTRUCTED WITH CONCRETE BLOCKS IN ACCORDANCE WITH THE DETAILS SHOWN ON STANDARD DRAWING DI-MB.
15. THIS AREA MAY BE EARTHEN, IN WHICH CASE THE EXPANSION JOINTS WILL APPLY ONLY TO CURB AND GUTTER.
16. CONCRETE QUANTITIES SHOWN ARE FOR DEPTH (H) OF 5'-2" WITHOUT PIPES. THE AMOUNT DISPLACED BY PIPES MUST BE DEDUCTED TO OBTAIN TRUE QUANTITIES. FOR INLETS OF DIFFERENT DEPTHS ADD OR SUBTRACT 0.44 CUBIC YARDS OF CONCRETE FOR EACH FOOT OF DEPTH.
17. LENGTH OF ANGLE IRON AS SHOWN ON SHEET 1 OF 2 IS TO BE L+16" AT 4.10 LBS./FT..
18. * DENOTES LENGTH OF ONE (1) BAR.
19. ALL REINFORCING BARS TO BE #5.



ROAD AND BRIDGE STANDARDS

STANDARD CURB DROP INLET (WITH UTILITY SPACE)

SPECIFICATION REFERENCE

SHEET 2 OF 2

REVISION DATE

12" - 30" PIPE: MAXIMUM DEPTH (H) - 8'

233
302

104.13

VIRGINIA DEPARTMENT OF TRANSPORTATION

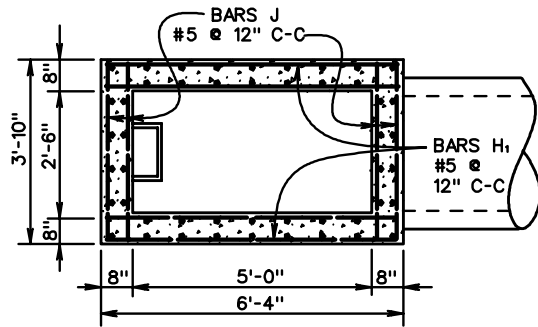

SECTION A-A

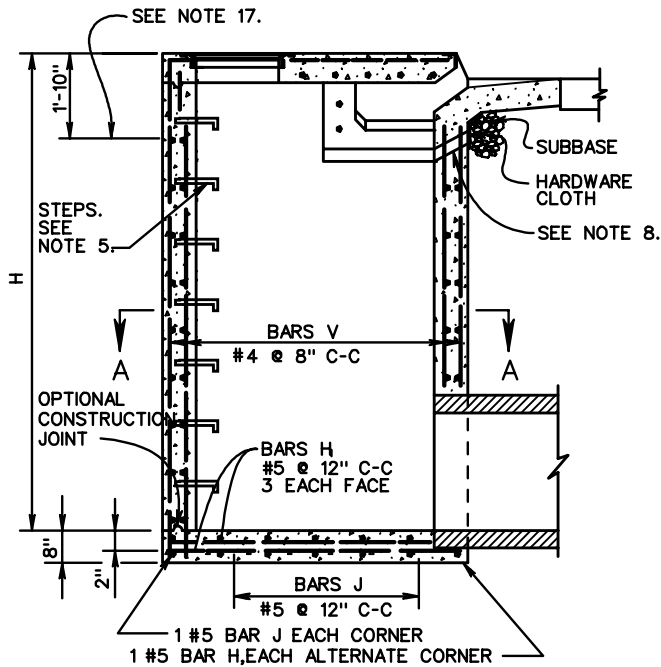

SECTION THROUGH ELEVATION

SCHEDULE OF REINFORCING STEEL					
BARS J		BARS H ₁		BARS V	
NO. REQ'D.	LENGTH	NO. REQ'D.	LENGTH	NO. REQ'D.	LENGTH
4X(H + 2)	3'-6"	4X(H + 1)	6'-0"	52	H - 1'-4"

- ### NOTES
- DEPTH OF INLET (H) TO BE SHOWN ON PLANS. MINIMUM DEPTH (H) TO BE 8'-0", MAXIMUM DEPTH TO BE 20'-0". FOR INLETS LESS THAN 8' USE STANDARD DI-3D, 3E, 3F.
 - THE "H" DIMENSION SHOWN ON THE STANDARDS AND SPECIFIED ON THE PLANS WILL BE MEASURED FROM THE INVERT OF THE OUTFALL PIPE TO THE TOP OF THE STRUCTURE. PLAN "H" DIMENSIONS ARE APPROXIMATE ONLY FOR ESTIMATING PURPOSES AND THE ACTUAL DIMENSIONS SHALL BE DETERMINED BY THE CONTRACTOR FROM FIELD CONDITIONS.
 - WHEN SPECIFIED ON THE PLANS THE INVERT IS TO BE SHAPED IN ACCORDANCE WITH STANDARD IS-1. THE COST OF FURNISHING AND PLACING ALL MATERIALS INCIDENTAL TO THE SHAPING IS TO BE INCLUDED IN THE BID PRICE FOR THE STRUCTURE.
 - IN THE EVENT THE INVERT OF THE OUTFALL PIPE IS HIGHER THAN THE BOTTOM OF THE STRUCTURE, THE INVERT OF THE STRUCTURE SHALL BE SHAPED WITH CEMENT MORTAR TO PREVENT STANDING OR PONDING OF WATER IN THE STRUCTURE. THE COST OF FURNISHING AND PLACING ALL MATERIALS INCIDENTAL TO THE SHAPING IS TO BE INCLUDED IN THE BID PRICE FOR THE STRUCTURE.
 - STEPS ARE REQUIRED. FOR DETAILS SEE STANDARD ST-1.
 - THIS ITEM MAY BE PRECAST OR CAST-IN-PLACE.
 - # 4 X 8" SMOOTH DOWELS AT APPROXIMATELY 12" C-C TO BE PLACED IN ALL AREAS ADJACENT TO ABUTTING CONCRETE TO PREVENT SETTLEMENT. IN LIEU OF DOWELS A 2" X 4" NOTCH MAY BE PROVIDED. SEE STANDARD T-DI-3, 4 FOR ALTERNATE DESIGN.
 - 3" DIAMETER WEEP HOLE TO BE LOCATED TO DRAIN SUBBASE MATERIAL. WEEP HOLE WITH 12"X12" PLASTIC HARDWARE CLOTH 1/4" MESH OR GALVANIZED STEEL WIRE, MINIMUM WIRE DIAMETER 0.03", NUMBER 4 MESH HARDWARE CLOTH ANCHORED FIRMLY TO THE OUTSIDE OF THE STRUCTURE.
 - ALL REINFORCING STEEL SHALL HAVE A MIN. COVER OF 2".
 - ALL REINFORCING STEEL TO BE CUT CLEAR OF ALL OPENINGS BY 2".
 - CAST-IN PLACE CONCRETE IS TO BE CLASS A3 (3000 PSI). PRECAST CONCRETE IS TO BE 4000 PSI.
 - LENGTH OF SLOT (L) WILL, IN EVERY CASE, BE SHOWN ON PLANS.
 - THIS STANDARD IS INTENDED FOR USE IN CURB AND GUTTER SITUATIONS ONLY.
 - IF OPTIONAL CONSTRUCTION JOINT IS USED IT IS TO BE KEYED. ALL SPLICES IN BARS V TO BE A MINIMUM OF 40 DIAMETER (20").
 - FOR PLAN VIEW OF INLET SEE STANDARD DI-3D, 3E, 3F.
 - CONCRETE QUANTITIES SHOWN ARE FOR MINIMUM INLETS OF EACH TYPE. FOR INLETS OF GREATER DEPTH (H) OR LONGER SLOTS (L) INCREMENTS SHOWN PER FOOT MUST BE ADDED. THE AMOUNT DISPLACED BY PIPES MUST BE DEDUCTED TO OBTAIN TRUE QUANTITIES.
 - FOR ALL DETAILS, DIMENSIONS, AND REINFORCING STEEL ABOVE THIS LINE SEE STANDARD DI-3D, 3E, 3F.
 - PROVIDE SAFETY SLABS WHEN SPECIFIED ON THE PLANS.
 - FOR DESCRIPTION AND LOCATION OF DIMENSION L SEE SHEET 104.12.
 - FOR NUMBER OF BARS A-H REQUIRED AND LENGTHS SEE SHEET 104.13.

APPROXIMATE QUANTITIES FOR MINIMUM 8' DEPTH INLET			
TYPE	DIMENSION L SEE NOTE 19	REINFORCING STEEL	CONCRETE
	LIN. FT.	LBS.	CU. YDS.
3DD	2'-6"	661	4.38
3EE	4'-0"	709	4.71
3FF	6'-0"	761	5.13

INCREMENTS TO BE ADDED FOR EACH ADDITIONAL FOOT OF DEPTH (H) AND/OR SLOT LENGTH (L)			
H		L	
CU. YDS. CONCRETE	LBS. STEEL	CU. YDS. CONCRETE	LBS. STEEL
0.431	75	-	-
0.431	75	0.22	23.5
0.431	75	0.22	23.5

SPECIFICATION REFERENCE
233
302

STANDARD CURB DROP INLET (WITH UTILITY SPACE)

12" - 30" PIPE: DEPTH (H) = 8' TO 20'

VIRGINIA DEPARTMENT OF TRANSPORTATION

VDOT ROAD AND BRIDGE STANDARDS	
REVISION DATE	SHEET 1 OF 1
104.14	

DI-4A, 4B, 4C

FOR DETAILS OF INLET FRAME & COVER SEE STANDARD IC-2.

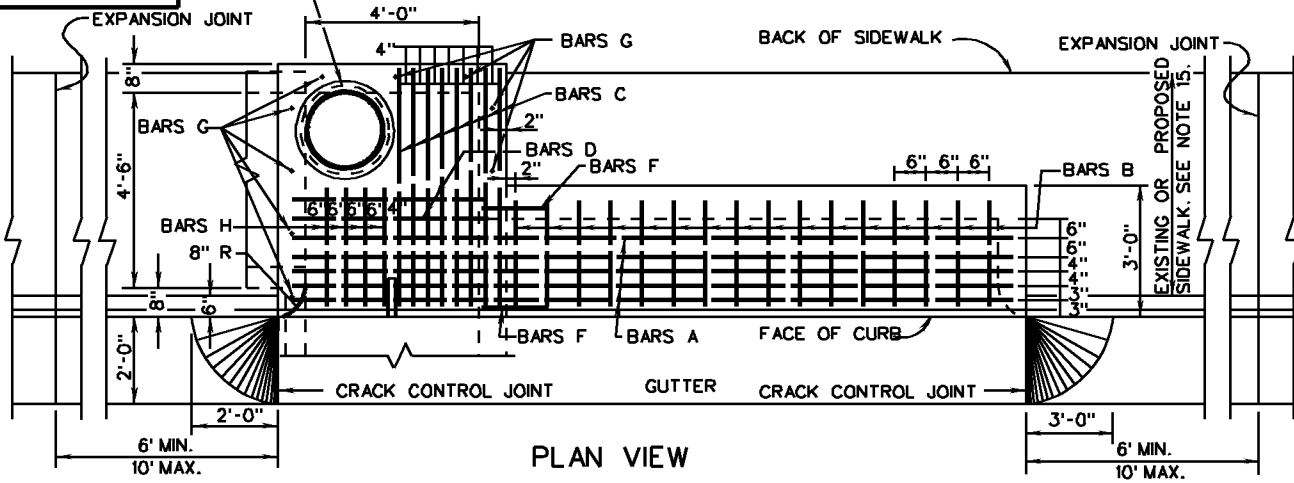

PLAN VIEW

GALVANIZED PLATE TO BE BENT ON AN ANGLE OF 68° 30' AND IS TO BE ANCHORED WITH 1/2" X 4" STUD SHEAR CONNECTORS WELDED TO BENT PLATE AT 2'-0" C-C.

TYPE A NOSE DETAIL SHALL BE USED WITH CG-3 AND CG-7 STANDARDS. TYPE B NOSE DETAIL SHALL BE USED WITH CG-2 AND CG-6 STANDARDS.

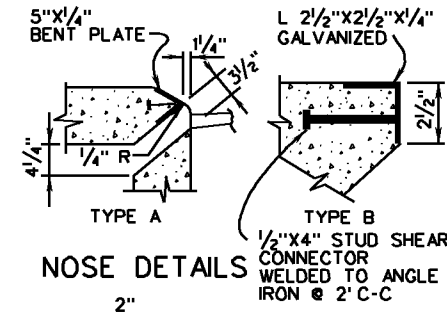

NOSE DETAILS

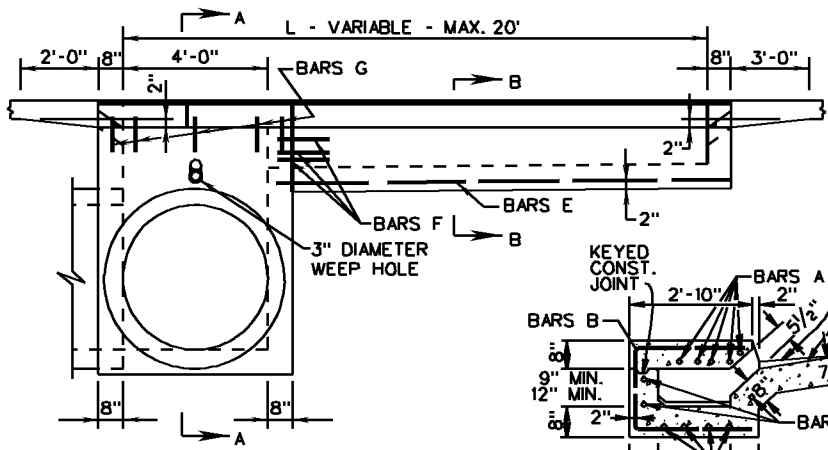

FRONT ELEVATION VIEW
(GUTTER REMOVED)

SECTION B-B

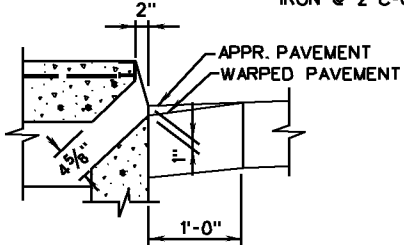

DETAIL WHEN USED
ADJACENT TO CURB
WITHOUT GUTTER

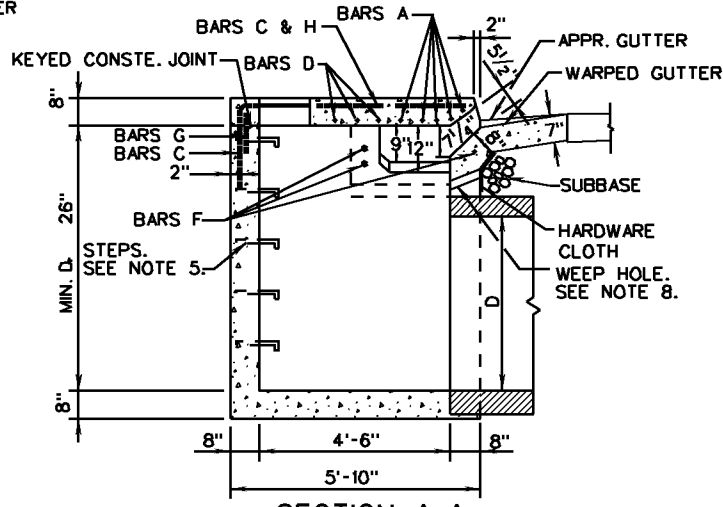

SECTION A-A

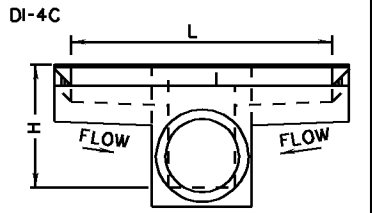
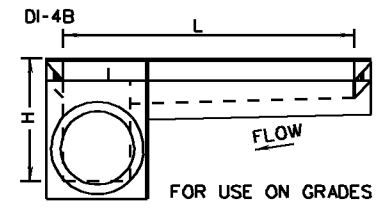
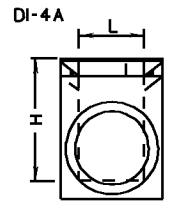

ROAD AND BRIDGE STANDARDS

STANDARD CURB DROP INLET

36" - 48" PIPE: MAXIMUM DEPTH (H) = 8'

VIRGINIA DEPARTMENT OF TRANSPORTATION

SPECIFICATION REFERENCE

SHEET 1 OF 2

REVISION DATE

233

104.15

10/09

302

TABLE OF QUANTITIES

DI-4A, 4B, 4C

TYPE	L Ft.	AREA OF SLOT Sq. Ft.	Concrete Cu. Yds.	REINFORCING STEEL												WEIGHT Lbs.				
				BARS A		BARS B		BARS C		BARS D		BARS E		BARS F			BARS G		BARS H	
				No.	Lin. Ft. *	No.	Lin. Ft. *	No.	Lin. Ft. *	No.	Lin. Ft. *	No.	Lin. Ft. *	No.	Lin. Ft. *		No.	Lin. Ft. *	No.	Lin. Ft. *
DI-4A	4'	1.83	4.65	5	4'-8"	-	-	6	7'-6"	2	4'-8"	-	-	-	-	11	1'-0"	4	2'-8"	104
DI-4B	6'	2.75	5.07	5	6'-8"	3	6'-7" to 6'-10"	8	7'-6"	2	4'-8"	4	2'-0"	3	1'-6"	9	1'-0"	4	2'-8"	162
	8'	3.67	5.51	5	8'-8"	7	6'-7" to 6'-10"	8	7'-6"	2	4'-8"	4	4'-0"	3	1'-6"	9	1'-0"	4	2'-8"	209
	10'	4.58	5.96	5	10'-8"	11	6'-7" to 6'-10"	8	7'-6"	2	4'-8"	4	6'-0"	3	1'-6"	9	1'-0"	4	2'-8"	256
	12'	5.50	6.40	5	12'-8"	15	6'-7" to 6'-10"	8	7'-6"	2	4'-8"	4	8'-0"	3	1'-6"	9	1'-0"	4	2'-8"	302
	14'	6.42	6.85	5	14'-8"	19	6'-7" to 6'-10"	8	7'-6"	2	4'-8"	4	10'-0"	3	1'-6"	9	1'-0"	4	2'-8"	349
	16'	7.33	7.30	5	16'-8"	23	6'-7" to 6'-10"	8	7'-6"	2	4'-8"	4	12'-0"	3	1'-6"	9	1'-0"	4	2'-8"	396
	18'	8.25	7.74	5	18'-8"	27	6'-7" to 6'-10"	8	7'-6"	2	4'-8"	4	14'-0"	3	1'-6"	9	1'-0"	4	2'-8"	443
DI-4C	20'	9.17	8.19	5	20'-8"	31	6'-7" to 6'-10"	8	7'-6"	2	4'-8"	4	16'-0"	3	1'-6"	9	1'-0"	4	2'-8"	489
	8'	3.67	5.48	5	8'-8"	6	6'-7" to 6'-10"	10	7'-6"	2	4'-8"	8	2'-0"	6	1'-6"	7	1'-0"	4	2'-8"	220
	10'	4.58	5.92	5	10'-8"	10	6'-7" to 6'-10"	10	7'-6"	2	4'-8"	8	3'-0"	6	1'-6"	7	1'-0"	4	2'-8"	267
	12'	5.50	6.37	5	12'-8"	14	6'-7" to 6'-10"	10	7'-6"	2	4'-8"	8	4'-0"	6	1'-6"	7	1'-0"	4	2'-8"	314
	14'	6.42	6.81	5	14'-8"	18	6'-7" to 6'-10"	10	7'-6"	2	4'-8"	8	5'-0"	6	1'-6"	7	1'-0"	4	2'-8"	360
	16'	7.33	7.26	5	16'-8"	22	6'-7" to 6'-10"	10	7'-6"	2	4'-8"	8	6'-0"	6	1'-6"	7	1'-0"	4	2'-8"	407
	18'	8.25	7.70	5	18'-8"	26	6'-7" to 6'-10"	10	7'-6"	2	4'-8"	8	7'-0"	6	1'-6"	7	1'-0"	4	2'-8"	454
	20'	9.17	8.15	5	20'-8"	30	6'-7" to 6'-10"	10	7'-6"	2	4'-8"	8	8'-0"	6	1'-6"	7	1'-0"	4	2'-8"	501

NOTES

1. DEPTH OF INLET (H) TO BE SHOWN ON PLANS.
2. THE "H" DIMENSION SHOWN ON THE STANDARDS AND SPECIFIED ON THE PLANS WILL BE MEASURED FROM THE INVERT OF THE OUTFALL PIPE TO THE TOP OF THE STRUCTURE. PLAN "H" DIMENSIONS ARE APPROXIMATE ONLY FOR ESTIMATING PURPOSES AND THE ACTUAL DIMENSIONS SHALL BE DETERMINED BY THE CONTRACTOR FROM FIELD CONDITIONS.
3. WHEN SPECIFIED ON THE PLANS THE INVERT IS TO BE SHAPED IN ACCORDANCE WITH STANDARD IS-1. THE COST OF FURNISHING AND PLACING ALL MATERIALS INCIDENTAL TO THE SHAPING IS TO BE INCLUDED IN THE BID PRICE FOR THE STRUCTURE.
4. IN THE EVENT THE INVERT OF THE OUTFALL PIPE IS HIGHER THAN THE BOTTOM OF THE STRUCTURE, THE INVERT OF THE STRUCTURE SHALL BE SHAPED WITH CEMENT MORTAR TO PREVENT STANDING OR PONDING OF WATER IN THE STRUCTURE. THE COST OF FURNISHING AND PLACING ALL MATERIALS INCIDENTAL TO THE SHAPING IS TO BE INCLUDED IN THE BID PRICE FOR THE STRUCTURE.
5. STEPS ARE TO BE PROVIDED WHEN H IS 4'-0" OR GREATER. FOR DETAILS SEE STANDARD ST-1.
6. THIS ITEM MAY BE PRECAST OR CAST-IN-PLACE.
7. # 4 X 8" SMOOTH DOWELS AT APPROXIMATELY 12" C-C TO BE PLACED IN ALL AREAS ADJACENT TO ABUTTING CONCRETE TO PREVENT SETTLEMENT.
8. 3" DIAMETER WEEP HOLE TO BE LOCATED TO DRAIN SUBBASE MATERIAL. WEEP HOLE WITH 12"X12" PLASTIC HARDWARE CLOTH 1/4" MESH OR GALVANIZED STEEL WIRE, MINIMUM WIRE DIAMETER 0.03", NUMBER 4 MESH HARDWARE CLOTH ANCHORED FIRMLY TO THE OUTSIDE OF THE STRUCTURE.
9. ALL REINFORCING STEEL SHALL HAVE A MIN. COVER OF 2".
10. ALL REINFORCING STEEL TO BE CUT CLEAR OF ALL OPENINGS BY 2".
11. CAST-IN PLACE CONCRETE IS TO BE CLASS A3 (3000 PSI). PRECAST CONCRETE IS TO BE 4000 PSI.
12. LENGTH OF SLOT (L) WILL IN EVERY CASE, BE SHOWN ON PLANS.
13. IF INLET IS CONSTRUCTED IN MEDIAN CURB OR WITH INTEGRAL CURB, GUTTER IS TO BE OMITTED (SEE DETAIL).
14. STANDARD INLETS MAY BE CONSTRUCTED WITH CONCRETE BLOCKS IN ACCORDANCE WITH THE DETAILS SHOWN ON STANDARD DRAWING DI-MB.
15. THIS AREA MAY BE EARTHEN, IN WHICH CASE THE EXPANSION JOINTS WILL APPLY ONLY TO CURB AND GUTTER.
16. CONCRETE QUANTITIES SHOWN ARE FOR DEPTH (H) OF 6'-10" WITHOUT PIPES. THE AMOUNT DISPLACED BY PIPES MUST BE DEDUCTED TO OBTAIN TRUE QUANTITIES. FOR INLETS OF DIFFERENT DEPTHS ADD OR SUBTRACT 0.49 CUBIC YARDS OF CONCRETE FOR EACH FOOT OF DEPTH.
17. LENGTH OF ANGLE IRON AS SHOWN ON SHEET 1 OF 2 IS TO BE L +16" AT 4.10 LBS./FT..
18. * DENOTES LENGTH OF ONE (1) BAR.
19. ALL REINFORCING BARS TO BE #5.

SPECIFICATION
REFERENCE

233
302

STANDARD CURB DROP INLET

36" - 48" PIPE: MAXIMUM DEPTH (H) - 8'

VIRGINIA DEPARTMENT OF TRANSPORTATION

VDOT

ROAD AND BRIDGE STANDARDS

REVISION DATE

SHEET 2 OF 2

104.16

DI-4AA, 4BB, 4CC

NOTES

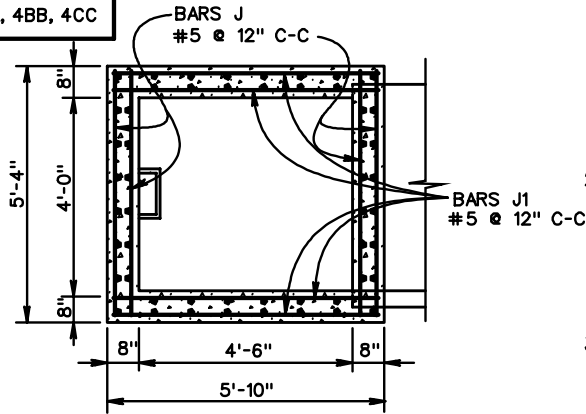

SECTION A-A

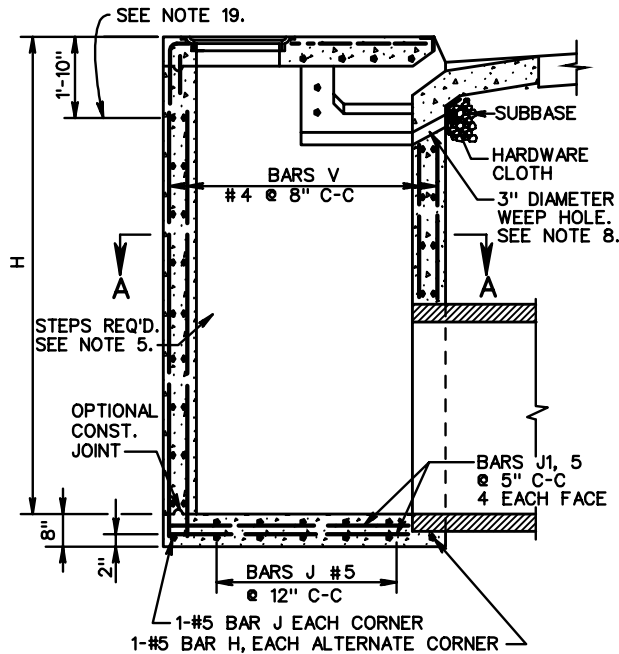

SECTION THROUGH ELEVATION

- DEPTH OF INLET (H) TO BE SHOWN ON PLANS. MINIMUM DEPTH (H) TO BE 8'-0". MAXIMUM DEPTH TO BE 20'-0". FOR INLETS LESS THAN 8' USE STANDARD DI-4A, 4B, AND 4C.
- THE "H" DIMENSION SHOWN ON THE STANDARDS AND SPECIFIED ON THE PLANS WILL BE MEASURED FROM THE INVERT OF THE OUTFALL PIPE TO THE TOP OF THE STRUCTURE. PLAN "H" DIMENSIONS ARE APPROXIMATE ONLY FOR ESTIMATING PURPOSES AND THE ACTUAL DIMENSIONS SHALL BE DETERMINED BY THE CONTRACTOR FROM FIELD CONDITIONS.
- WHEN SPECIFIED ON THE PLANS THE INVERT IS TO BE SHAPED IN ACCORDANCE WITH STANDARD IS-1. THE COST OF FURNISHING AND PLACING ALL MATERIALS INCIDENTAL TO THE SHAPING IS TO BE INCLUDED IN THE BID PRICE FOR THE STRUCTURE.
- IN THE EVENT THE INVERT OF THE OUTFALL PIPE IS HIGHER THAN THE BOTTOM OF THE STRUCTURE, THE INVERT OF THE STRUCTURE SHALL BE SHAPED WITH CEMENT MORTAR TO PREVENT STANDING OR PONDING OF WATER IN THE STRUCTURE. THE COST OF FURNISHING AND PLACING ALL MATERIALS INCIDENTAL TO THE SHAPING IS TO BE INCLUDED IN THE BID PRICE FOR THE STRUCTURE.
- STEPS ARE TO BE PROVIDED. FOR DETAILS SEE STANDARD ST-1.
- THIS ITEM MAY BE PRECAST OR CAST-IN-PLACE.
- #4 X 8" SMOOTH DOWELS AT APPROXIMATELY 12" C-C TO BE PLACED IN ALL AREAS ADJACENT TO ABUTTING CONCRETE TO PREVENT SETTLEMENT. IN LIEU OF DOWELS A 2" X 4" NOTCH MAY BE PROVIDED. SEE STANDARD T-DI-3, 4 FOR ALTERNATE DESIGN.
- 3" DIAMETER WEEP HOLE TO BE LOCATED TO DRAIN SUBBASE MATERIAL. WEEP HOLE WITH 12"X12" PLASTIC HARDWARE CLOTH 1/4" MESH OR GALVANIZED STEEL WIRE, MINIMUM WIRE DIAMETER 0.03", NUMBER 4 MESH HARDWARE CLOTH ANCHORED FIRMLY TO THE OUTSIDE OF THE STRUCTURE.
- ALL REINFORCING STEEL SHALL HAVE A MIN. COVER OF 2".
- ALL REINFORCING STEEL TO BE CUT CLEAR OF ALL OPENINGS BY 2".
- CAST-IN PLACE CONCRETE IS TO BE CLASS A3 (3000 PSI). PRECAST CONCRETE IS TO BE 4000 PSI.
- LENGTH OF SLOT (L) WILL, IN EVERY CASE, BE SHOWN ON PLANS.
- IF INLET IS CONSTRUCTED IN MEDIAN CURB OR WITH INTEGRAL CURB, GUTTER IS TO BE OMITTED (SEE DETAIL WITH STANDARD DI-4A, 4B, 4C).
- IF OPTIONAL CONSTRUCTION JOINT IS USED IT IS TO BE KEYPED. ALL SPLICES IN BARS V TO BE A MINIMUM OF 40 DIAMETERS (20").
- FOR PLAN VIEW OF INLET SEE STANDARD DI-4A, 4B, 4C.
- QUANTITIES SHOWN ARE FOR MINIMUM INLETS OF EACH TYPE. FOR INLETS OF GREATER DEPTH (H) OR LONGER SLOT (L) INCREMENTS SHOWN PER FOOT MUST BE ADDED. THE AMOUNT OF CONCRETE AND STEEL DISPLACED BY PIPES MUST BE DEDUCTED TO OBTAIN TRUE QUANTITIES.
- FOR NUMBER OF BARS A-H REQUIRED AND LENGTH SEE TABLE OF QUANTITIES FOR STANDARD DI-4A, 4B, 4C.
- FOR DESCRIPTION AND LOCATION OF DIMENSION L SEE SHEET STANDARD DI-4A, 4B, 4C.
- FOR ALL DETAILS, DIMENSIONS AND REINFORCING STEEL ABOVE THIS LINE, SEE STANDARD DI-4A, 4B, AND 4C.
- PROVIDE SAFETY SLABS WHEN SPECIFIED ON THE PLANS.

APPROXIMATE QUANTITIES FOR MINIMUM 8' DEPTH INLET

TYPE	DIMENSION L SEE NOTE 18	REINFORCING STEEL	CONCRETE
	LIN. FT.	LBS.	CU. YDS.
4AA	4'-0"	798	5.14
4BB	6'-0"	856	5.56
4CC	8'-0"	914	5.97

INCREMENTS TO BE ADDED FOR EACH ADDITIONAL FOOT OF DEPTH (H) AND/OR SLOT LENGTH (L)

H		L	
CONCRETE CU. YDS.	STEEL LBS.	CONCRETE CU. YDS.	STEEL LBS.
0.479	84	-	-
0.479	84	0.22	23.5
0.479	84	0.22	23.5

SCHEDULE OF REINFORCING STEEL
SEE NOTE 17.

BARS J		BARS J1		BARS V	
NO. REQUIRED	LENGTH	NO. REQUIRED	LENGTH	NO. REQUIRED	LENGTH
4X(H + 2)	5'-0"	4H+6	5'-6"	60	H-1'-4"



ROAD AND BRIDGE STANDARDS

SHEET 1 OF 1

REVISION DATE

104.17

STANDARD CURB DROP INLET

36" - 48" PIPE: DEPTH (H) 8' TO 20'

VIRGINIA DEPARTMENT OF TRANSPORTATION

SPECIFICATION REFERENCE

233
302

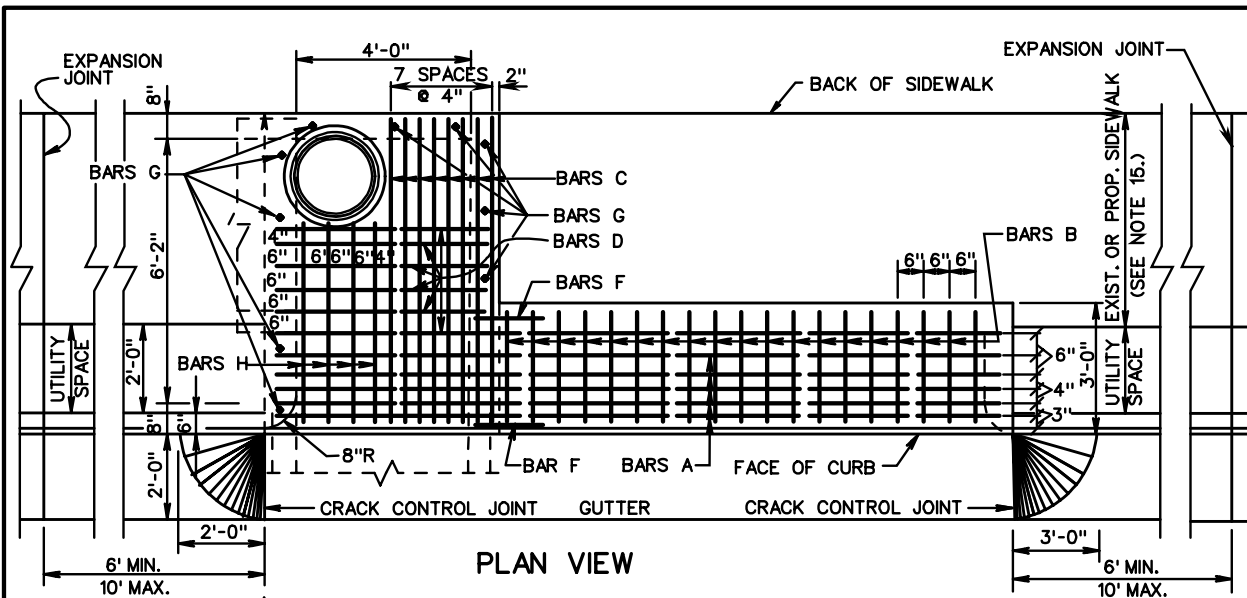

PLAN VIEW

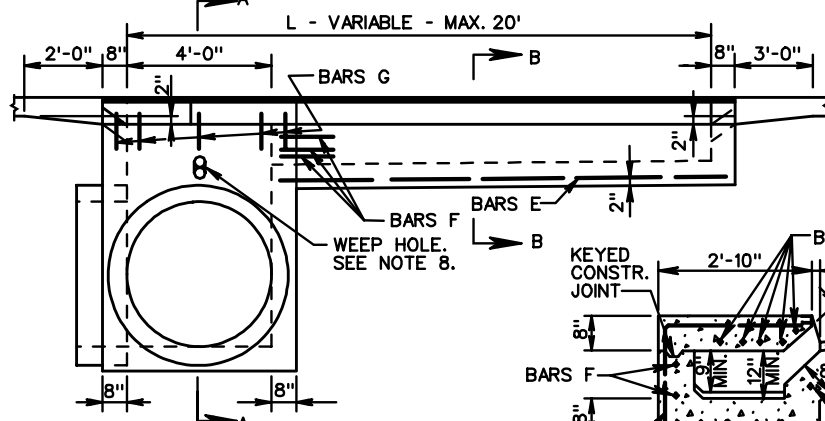

FRONT ELEVATION VIEW
(GUTTER REMOVED)

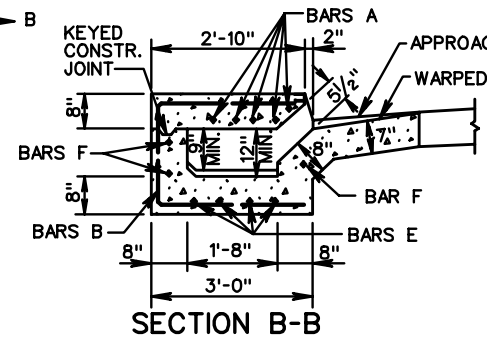

SECTION B-B

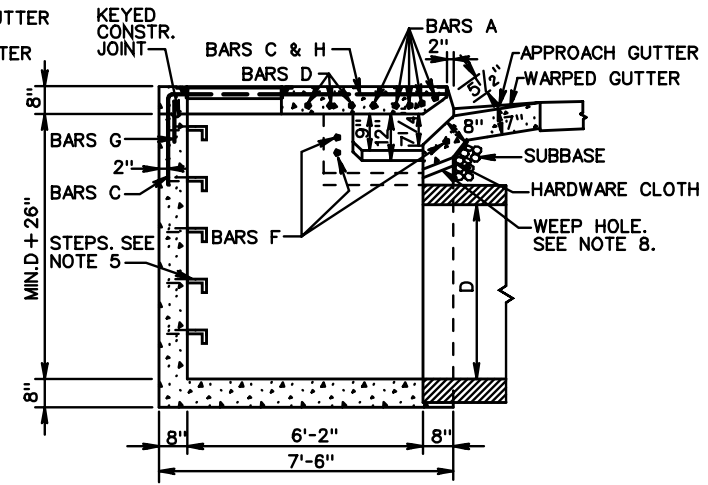

SECTION A-A

GALVANIZED PLATE TO BE BENT ON AN ANGLE OF 68° 30' & IS TO BE ANCHORED WITH 1/2" X 4" STUD SHEAR CONN. WELDED TO BENT PLATE AT 2' C-C.

TYPE A NOSE DETAIL SHALL BE USED WITH CG-3 AND CG-7 STANDARDS. TYPE B NOSE DETAIL SHALL BE USED WITH CG-2 AND CG-6 STANDARDS.

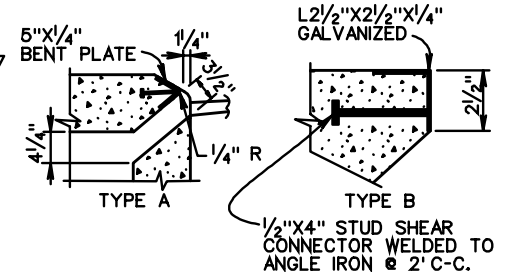

NOSE DETAILS

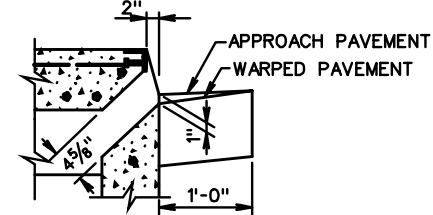

DETAIL WHEN USED
ADJACENT TO CURB
WITHOUT GUTTER

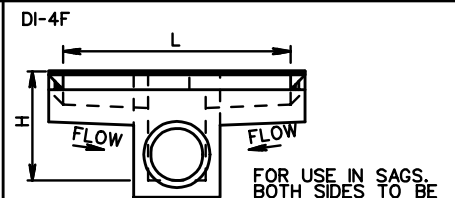
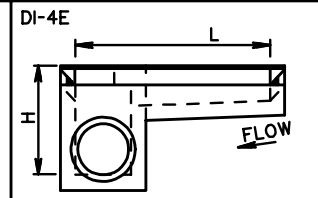
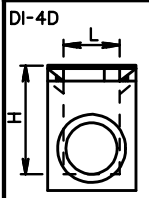

SPECIFICATION REFERENCE
233 302

STANDARD CURB DROP INLET

36" - 48" PIPE: MAXIMUM DEPTH (H) = 8' (WITH UTILITY SPACE)
54" - 60" MAX. PIPE: MAX. (H) = 8' (WITHOUT UTILITY SPACE)

VIRGINIA DEPARTMENT OF TRANSPORTATION

VDOT	
ROAD AND BRIDGE STANDARDS	
REVISION DATE	SHEET 1 OF 2
	104.18

TABLE OF QUANTITIES

TYPE	L	AREA OF SLOT	Concrete	REINFORCING STEEL												WEIGHT				
				BARS A		BARS B		BARS C		BARS D		BARS E		BARS F			BARS G		BARS H	
				No.	Lin. Ft. *	No.	Lin. Ft. *	No.	Lin. Ft. *	No.	Lin. Ft. *	No.	Lin. Ft. *	No.	Lin. Ft. *		No.	Lin. Ft. *	No.	Lin. Ft. *
DI-4D	4'	1.83	5.60	5	4'-8"	-	-	6	9'-2"	6	4'-8"	-	-	-	-	13	1'-0"	4	4'-6"	144
DI-4E	6'	2.75	6.02	5	6'-8"	3	6'-7" to 6'-10"	8	9'-2"	6	4'-8"	4	2'-0"	3	1'-6"	11	1'-0"	4	4'-6"	205
	8'	3.67	6.46	5	8'-8"	7	6'-7" to 6'-10"	8	9'-2"	6	4'-8"	4	4'-0"	3	1'-6"	11	1'-0"	4	4'-6"	252
	10'	4.58	6.91	5	10'-8"	11	6'-7" to 6'-10"	8	9'-2"	6	4'-8"	4	6'-0"	3	1'-6"	11	1'-0"	4	4'-6"	299
	12'	5.50	7.35	5	12'-8"	15	6'-7" to 6'-10"	8	9'-2"	6	4'-8"	4	8'-0"	3	1'-6"	11	1'-0"	4	4'-6"	345
	14'	6.42	7.80	5	14'-8"	19	6'-7" to 6'-10"	8	9'-2"	6	4'-8"	4	12'-0"	3	1'-6"	11	1'-0"	4	4'-6"	392
	16'	7.33	8.25	5	16'-8"	23	6'-7" to 6'-10"	8	9'-2"	6	4'-8"	4	10'-0"	3	1'-6"	11	1'-0"	4	4'-6"	439
	18'	8.25	8.69	5	18'-8"	27	6'-7" to 6'-10"	8	9'-2"	6	4'-8"	4	14'-0"	3	1'-6"	11	1'-0"	4	4'-6"	486
	20'	9.17	9.14	5	20'-8"	31	6'-7" to 6'-10"	8	9'-2"	6	4'-8"	4	16'-0"	3	1'-6"	11	1'-0"	4	4'-6"	532
DI-4F	8'	3.67	6.43	5	8'-8"	6	6'-7" to 6'-10"	10	9'-2"	6	4'-8"	8	2'-0"	6	1'-6"	9	1'-0"	4	4'-6"	267
	10'	4.58	6.87	5	10'-8"	10	6'-7" to 6'-10"	10	9'-2"	6	4'-8"	8	3'-0"	6	1'-6"	9	1'-0"	4	4'-6"	313
	12'	5.50	7.32	5	12'-8"	14	6'-7" to 6'-10"	10	9'-2"	6	4'-8"	8	4'-0"	6	1'-6"	9	1'-0"	4	4'-6"	360
	14'	6.42	7.76	5	14'-8"	18	6'-7" to 6'-10"	10	9'-2"	6	4'-8"	8	5'-0"	6	1'-6"	9	1'-0"	4	4'-6"	407
	16'	7.33	8.21	5	16'-8"	22	6'-7" to 6'-10"	10	9'-2"	6	4'-8"	8	6'-0"	6	1'-6"	9	1'-0"	4	4'-6"	454
	18'	8.25	8.65	5	18'-8"	26	6'-7" to 6'-10"	10	9'-2"	6	4'-8"	8	7'-0"	6	1'-6"	9	1'-0"	4	4'-6"	500
	20'	9.17	9.10	5	20'-8"	30	6'-7" to 6'-10"	10	9'-2"	6	4'-8"	8	8'-0"	6	1'-6"	9	1'-0"	4	4'-6"	547

NOTES

- DEPTH OF INLET (H) TO BE SHOWN ON PLANS.
- THE "H" DIMENSION SHOWN ON THE STANDARDS AND SPECIFIED ON THE PLANS WILL BE MEASURED FROM THE INVERT OF THE OUTFALL PIPE TO THE TOP OF THE STRUCTURE. PLAN "H" DIMENSIONS ARE APPROXIMATE ONLY FOR ESTIMATING PURPOSES AND THE ACTUAL DIMENSIONS SHALL BE DETERMINED BY THE CONTRACTOR FROM FIELD CONDITIONS.
- WHEN SPECIFIED ON THE PLANS THE INVERT IS TO BE SHAPED IN ACCORDANCE WITH STANDARD IS-1. THE COST OF FURNISHING AND PLACING ALL BE MATERIALS INCIDENTAL TO THE SHAPING IS TO INCLUDED IN THE BID PRICE FOR THE STRUCTURE.
- IN THE EVENT THE INVERT OF THE OUTFALL PIPE IS HIGHER THAN THE BOTTOM OF THE STRUCTURE, THE INVERT OF THE STRUCTURE SHALL BE SHAPED WITH CEMENT MORTAR TO PREVENT STANDING OR PONDING OF WATER IN THE STRUCTURE. THE COST OF FURNISHING AND PLACING ALL MATERIALS INCIDENTAL TO THE SHAPING IS TO BE INCLUDED IN THE BID PRICE FOR THE STRUCTURE.
- STEPS ARE TO BE PROVIDED WHEN H IS 4'-0" OR GREATER. FOR DETAILS SEE STANDARD ST-1.
- THIS ITEM MAY BE PRECAST OR CAST-IN-PLACE.
- # 4 X 8" SMOOTH DOWELS AT APPROXIMATELY 12" C-C TO BE PLACED IN ALL AREAS ADJACENT TO ABUTTING CONCRETE TO PREVENT SETTLEMENT. IN LIEU OF DOWELS A 2" X 4" NOTCH MAY BE PROVIDED. SEE STANDARD T-DI-3, 4 FOR ALTERNATE DESIGN.
- 3" DIAMETER WEEP HOLE TO BE LOCATED TO DRAIN SUBBASE MATERIAL. WEEP HOLE WITH 12"X12" PLASTIC HARDWARE CLOTH 1/4" MESH OR GALVANIZED STEEL WIRE, MINIMUM WIRE DIAMETER 0.03", NUMBER 4 MESH HARDWARE CLOTH ANCHORED FIRMLY TO THE OUTSIDE OF THE STRUCTURE.
- ALL REINFORCING STEEL SHALL HAVE A MIN. COVER OF 2".
- ALL REINFORCING STEEL TO BE CUT CLEAR OF ALL OPENINGS BY 2".
- CAST-IN PLACE CONCRETE IS TO BE CLASS A3 (3000 PSI). PRECAST CONCRETE IS TO BE 4000 PSI.
- THIS STANDARD IS INTENDED FOR USE IN CURB AND GUTTER SITUATIONS ONLY.
- IF INLET IS CONSTRUCTED IN MEDIAN CURB OR WITH INTEGRAL CURB, GUTTER IS TO BE OMITTED (SEE DETAIL).
- STANDARD INLETS MAY BE CONSTRUCTED WITH CONCRETE BLOCKS IN ACCORDANCE WITH THE DETAILS SHOWN ON STANDARD DRAWING DI-MB.
- THIS AREA MAY BE EARTHEN, IN WHICH CASE THE EXPANSION JOINTS WILL APPLY ONLY TO CURB AND GUTTER.
- CONCRETE QUANTITIES SHOWN ARE FOR DEPTH (H) OF 5'-2" WITHOUT PIPES. THE AMOUNT DISPLACED BY PIPES MUST BE DEDUCTED TO OBTAIN TRUE QUANTITIES. FOR INLETS OF DIFFERENT DEPTHS ADD OR SUBTRACT 0.28 CUBIC YARDS OF CONCRETE FOR EACH FOOT OF DEPTH.
- LENGTH OF ANGLE IRON AS SHOWN ON SHEET 1 OF 2 IS TO BE L+16" AT 4.10 LBS./FT..
- X DENOTES LENGTH OF ONE (1) BAR.
- ALL REINFORCING BARS TO BE #5.
- INLET MAY BE USED WITH LARGER LONGITUDINAL PIPES (60" MAXIMUM) PROVIDED UTILITY SPACE CLEARANCE IS NOT NEEDED, HORIZONTAL CLEARANCE BETWEEN ADJACENT PIPES IS ADEQUATE AND MINIMUM HEIGHT (H) EQUALS PIPE DIAMETER PLUS 3 FEET.



ROAD AND BRIDGE STANDARDS

STANDARD CURB DROP INLET (WITH UTILITY SPACE)

SPECIFICATION REFERENCE

SHEET 2 OF 2

REVISION DATE

36" - 48" PIPE: MAXIMUM DEPTH (H) - 8'

233
302

104.19

VIRGINIA DEPARTMENT OF TRANSPORTATION

NOTES

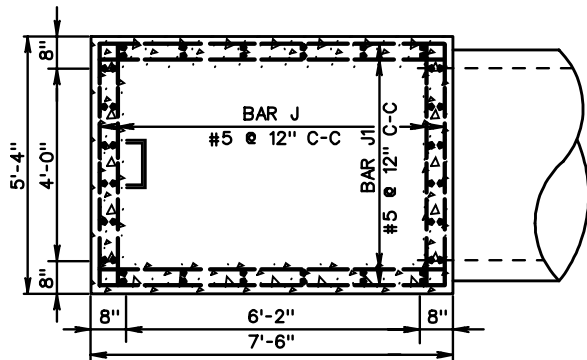

SECTION A-A

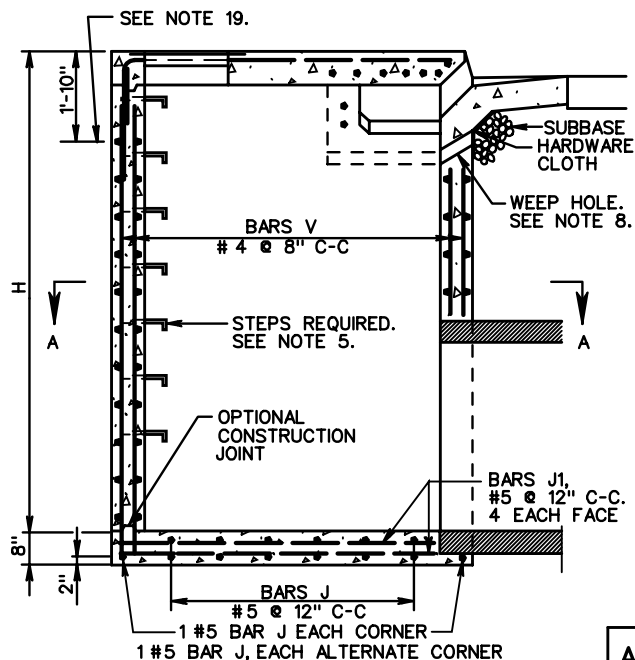

SECTION THROUGH ELEVATION

SCHEDULE OF REINFORCING STEEL (SEE NOTE 17)					
BARS J		BARS J1		BARS V	
NO. REQ'D.	LENGTH	NO. REQ'D.	LENGTH	NO. REQ'D.	LENGTH
4H + 10	5'-0"	4H + 6	7'-2"	72	H-1'-4"

APPROXIMATE QUANTITIES FOR MINIMUM 8' DEPTH INLET			
TYPE	DIMENSION L SEE NOTE 18	REINFORCING STEEL	CONC.
DI-	LIN. FT.	LBS.	CU. YDS.
4DD	4'-0"	968	6.19
4EE	6'-0"	1029	6.61
4FF	8'-0"	1091	7.02

INCREMENTS TO BE ADDED FOR EACH ADDITIONAL FOOT OF DEPTH (H) AND/OR SLOT LENGTH (L)			
H		L	
CONC. CU. YDS.	STEEL LBS.	CONC. CU. YDS.	STEEL LBS.
0.560	99	—	—
0.560	99	0.22	23.5
0.560	99	0.22	23.5

- DEPTH OF INLET (H) TO BE SHOWN ON PLANS. MINIMUM DEPTH (H) TO BE 8'-0". MAXIMUM DEPTH TO BE 16'-0". FOR INLETS LESS THAN 8' USE STANDARD DI-4D, 4E, AND 4F.
- THE "H" DIMENSION SHOWN ON THE STANDARDS AND SPECIFIED ON THE PLANS WILL BE MEASURED FROM THE INVERT OF THE OUTFALL PIPE TO THE TOP OF THE STRUCTURE. PLAN "H" DIMENSIONS ARE APPROXIMATE ONLY FOR ESTIMATING PURPOSES AND THE ACTUAL DIMENSIONS SHALL BE DETERMINED BY THE CONTRACTOR FROM FIELD CONDITIONS.
- WHEN SPECIFIED ON THE PLANS THE INVERT IS TO BE SHAPED IN ACCORDANCE WITH STANDARD IS-1. THE COST OF FURNISHING AND PLACING ALL MATERIALS INCIDENTAL TO THE SHAPING IS TO BE INCLUDED IN THE BID PRICE FOR THE STRUCTURE.
- IN THE EVENT THE INVERT OF THE OUTFALL PIPE IS HIGHER THAN THE BOTTOM OF THE STRUCTURE, THE INVERT OF THE STRUCTURE SHALL BE SHAPED WITH CEMENT MORTAR TO PREVENT STANDING OR PONDING OF WATER IN THE STRUCTURE. THE COST OF FURNISHING AND PLACING ALL MATERIALS INCIDENTAL TO THE SHAPING IS TO BE INCLUDED IN THE BID PRICE FOR THE STRUCTURE.
- STEPS ARE TO BE PROVIDED. FOR DETAILS SEE STANDARD ST-1.
- THIS ITEM MAY BE PRECAST OR CAST-IN-PLACE.
- #4 X 8" SMOOTH DOWELS AT APPROXIMATELY 12" C-C TO BE PLACED IN ALL AREAS ADJACENT TO ABUTTING CONCRETE TO PREVENT SETTLEMENT. IN LIEU OF DOWELS A 2" X 4" NOTCH MAY BE PROVIDED. SEE STANDARD T-DI-3, 4 FOR ALTERNATE DESIGN.
- 3" DIAMETER WEEP HOLE TO BE LOCATED TO DRAIN SUBBASE MATERIAL. WEEP HOLE WITH 12"X12" PLASTIC HARDWARE CLOTH 1/4" MESH OR GALVANIZED STEEL WIRE, MINIMUM WIRE DIAMETER 0.03", NUMBER 4 MESH HARDWARE CLOTH ANCHORED FIRMLY TO THE OUTSIDE OF THE STRUCTURE.
- ALL REINFORCING STEEL SHALL HAVE A MIN. COVER OF 2".
- ALL REINFORCING STEEL TO BE CUT CLEAR OF ALL OPENINGS BY 2".
- CAST-IN PLACE CONCRETE IS TO BE CLASS A3 (3000 PSI). PRECAST CONCRETE IS TO BE 4000 PSI.
- LENGTH OF SLOT (L) WILL, IN EVERY CASE, BE SHOWN ON PLANS.
- IF INLET IS CONSTRUCTED IN MEDIAN CURB OR WITH INTEGRAL CURB, GUTTER IS TO BE OMITTED (SEE DETAIL WITH STANDARD DI-4D, 4E, 4F).
- IF OPTIONAL CONSTRUCTION JOINT IS USED IT IS TO BE KEED. ALL SPLICES IN BARS V TO BE A MINIMUM OF 40 DIAMETER (20").
- FOR PLAN VIEW OF INLET SEE STANDARD DI-4D, 4E, 4F.
- CONCRETE QUANTITIES SHOWN ARE FOR DEPTH (H) OF 5'-2" WITHOUT PIPES. THE AMOUNT DISPLACED BY PIPES MUST BE DEDUCTED TO OBTAIN TRUE QUANTITIES. FOR INLETS OF DIFFERENT DEPTHS ADD OR SUBTRACT 0.28 CUBIC YARDS OF CONCRETE FOR EACH FOOT OF DEPTH.
- FOR NUMBER OF BARS A-H REQUIRED AND LENGTH SEE TABLE OF QUANTITIES FOR STANDARD DI-4D, 4E, 4F.
- FOR DESCRIPTION AND LOCATION OF DIMENSION L SEE SHEET STANDARD DI-4D, 4E, 4F.
- FOR ALL DETAILS, DIMENSIONS AND REINFORCING STEEL ABOVE THIS LINE, SEE STANDARD DI-4D, 4E, AND 4F.
- INLET MAY BE USED WITH LARGER LONGITUDINAL PIPE (72" MAXIMUM), PROVIDED UTILITY SPACE CLEARANCE IS NOT NEEDED, HORIZONTAL CLEARANCE BETWEEN ADJACENT PIPES IS ADEQUATE AND MINIMUM HEIGHT (H) EQUALS PIPE DIAMETER PLUS 3 FEET.
- PROVIDE SAFETY SLABS WHEN SPECIFIED ON THE PLANS.

SPECIFICATION REFERENCE

233
302

STANDARD CURB DROP INLET (WITH UTILITY SPACE)

36" - 48" PIPE: DEPTH (H) 8' TO 16'

VIRGINIA DEPARTMENT OF TRANSPORTATION



ROAD AND BRIDGE STANDARDS

REVISION DATE

SHEET 1 OF 1

104.20

DI-5

NOTES

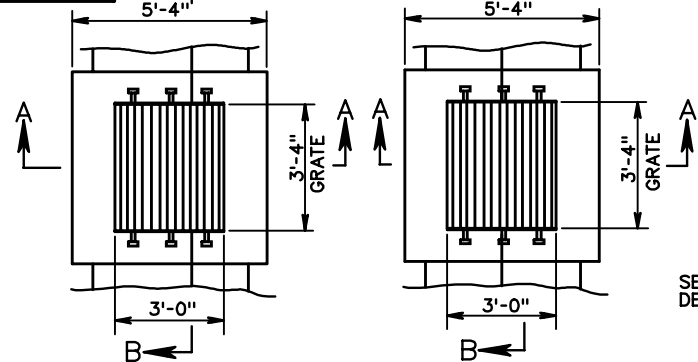

DITCH PLAN

MEDIAN PLAN

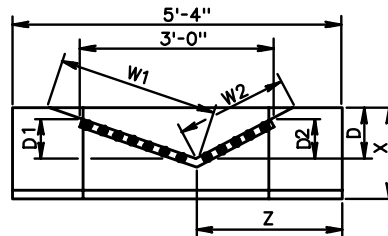

SECTION A-A

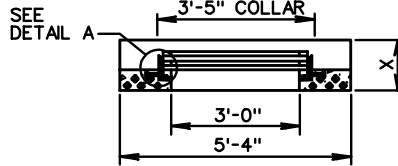

SECTION B-B

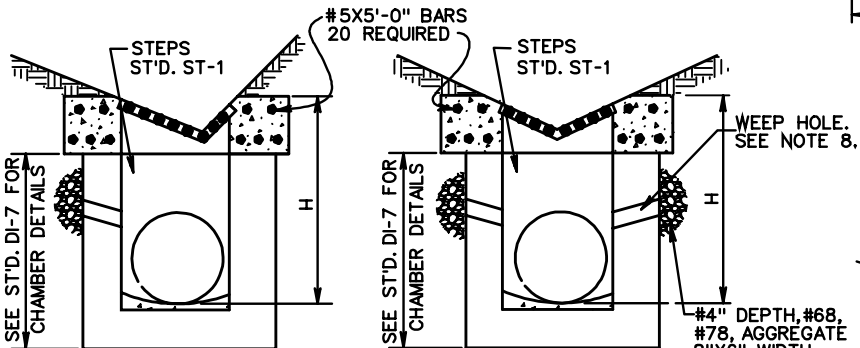

DITCH LINE SECTION

MEDIAN DITCH SECTION

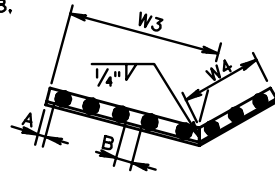

GRATE (GALVANIZED)

COLLAR DIMENSIONS TO BE 1/4" LARGER THAN GRATE DIMENSIONS W3 AND W4.

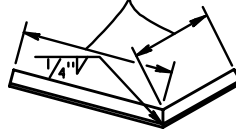

COLLAR (GALVANIZED)

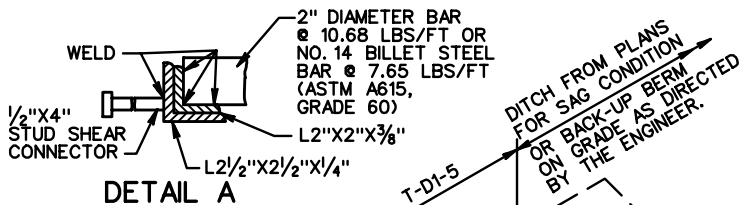

DETAIL A

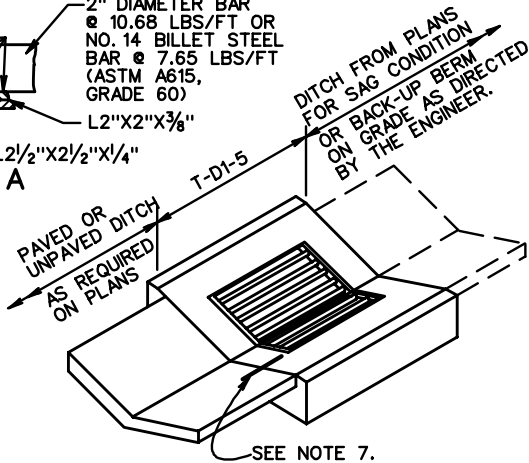

SEE NOTE 7.

1. DEPTH OF INLET (H) TO BE SHOWN ON PLANS.
2. THE "H" DIMENSION SHOWN ON THE STANDARDS AND SPECIFIED ON THE PLANS WILL BE MEASURED FROM THE INVERT OF THE OUTFALL PIPE TO THE TOP OF THE STRUCTURE. PLAN "H" DIMENSIONS ARE APPROX. ONLY FOR ESTIMATING PURPOSES AND THE ACTUAL DIMENSIONS SHALL BE DETERMINED BY THE CONTRACTOR FROM FIELD CONDITIONS.
3. WHEN SPECIFIED ON THE PLANS THE INVERT IS TO BE SHAPED IN ACCORDANCE WITH STANDARD IS-1. THE COST OF FURNISHING AND PLACING ALL MATERIALS INCIDENTAL TO THE SHAPING IS TO BE INCLUDED IN THE BID PRICE FOR THE STRUCTURE.
4. IN THE EVENT THE INVERT OF THE OUTFALL PIPE IS HIGHER THAN THE BOTTOM OF THE STRUCTURE, THE INVERT OF THE STRUCTURE SHALL BE SHAPED WITH CEMENT MORTAR TO PREVENT STANDING OR PONDING OF WATER IN THE STRUCTURE. THE COST OF FURNISHING AND PLACING ALL MATERIALS INCIDENTAL TO THE SHAPING IS TO BE INCLUDED IN THE BID PRICE FOR THE STRUCTURE.
5. STEPS ARE TO BE PROVIDED WHEN H IS 4'-0" OR GREATER. FOR DETAILS SEE STANDARD ST-1.
6. CHAMBER MAY BE CAST IN PLACE, PRECAST, BRICK OR CONCRETE BLOCK. SEE DI-7 FOR DETAILS.
7. WHERE PAVED DITCHES ARE REQUIRED, JOINTS ARE TO BE DOWELED WITH #4 X 8" SMOOTH RODS AT APPROXIMATELY 12" C-C IN ALL AREAS ADJACENT TO ABUTTING CONCRETE TO PREVENT SETTLEMENT. IN LIEU OF DOWELS A 2" X 4" NOTCH MAY BE PROVIDED. SEE ST'D T-DI-3, 4 FOR ALTERNATE DESIGN.
8. 3" DIAMETER WEEP HOLE TO BE LOCATED TO DRAIN SUBBASE MATERIAL. WEEP HOLE WITH 12"X12" PLASTIC HARDWARE CLOTH 1/4" MESH OR GALVANIZED STEEL WIRE, MINIMUM WIRE DIAMETER 0.03", NUMBER 4 MESH HARDWARE CLOTH ANCHORED FIRMLY TO THE OUTSIDE OF THE STRUCTURE.
9. ALL REINFORCING STEEL SHALL HAVE A MINIMUM COVER OF 2" AND BE CUT CLEAR OF ALL OPENINGS BY 2".
10. CAST-IN PLACE CONCRETE IS TO BE CLASS A3 (3000 PSI). PRECAST CONCRETE IS TO BE 4000 PSI.
11. PROVIDED SAFETY SLABS WHEN SPECIFIED ON THE PLANS.
12. DI-5 IS TO BE UTILIZED IN LOCATIONS NOT NORMALLY SUBJECT TO TRAFFIC.

MINIMUM H	
PIPE SIZE	H
12"	2'-9"
15"	3'-0"
18"	3'-4"
24"	3'-10"
30"	4'-5"
36"	5'-0"
42"	5'-6"

GRATE BAR SPACING CHART		
GRATE TYPE	MAXIMUM DIMENSION	
	A	B
A I	1 1/2"	3"
A III	1"	1"

ST'D PG-2A TYPE	COVER DIMENSIONS AND QUANTITIES								
	W1	W2	W3	W4	*D	D1	D2	X	Z
A1,A2,A3	3'-0 1/2"	2'-0 3/4"	2'-0 5/8"	1'-0 3/8"	6"	4"	3"	14"	2'-2"
B1,B2,B3,B4 C1,C2,C3	2'-9"	2'-9"	1'-6 9/16"	1'-6 9/16"	8"	4 1/2"	4 1/2"	16"	2'-8"
E	2'-3"	2'-3"	1'-8 1/16"	1'-8 1/16"	12"	9"	9"	19"	2'-8"

* TOLERANCE ± 1/2"



ROAD AND BRIDGE STANDARDS

SHEET 1 OF 1

REVISION DATE

104.21

STANDARD DITCH DROP INLET

VIRGINIA DEPARTMENT OF TRANSPORTATION

SPECIFICATION REFERENCE

233
302

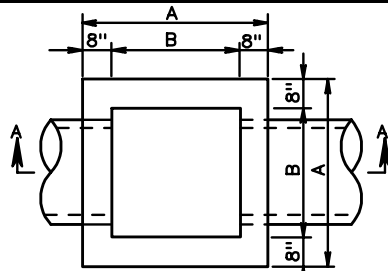

PLAN
(COVER REMOVED)
A-4'-4" (12" - 36" PIPE)
B-3'-0" (12" - 36" PIPE)
A-4'-10" (42" PIPE)
B-3'-6" (42" PIPE)

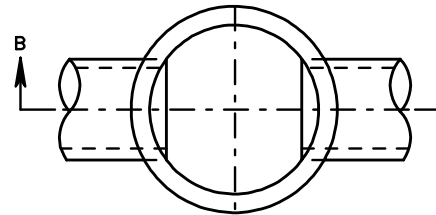

PLAN
(COVER REMOVED)

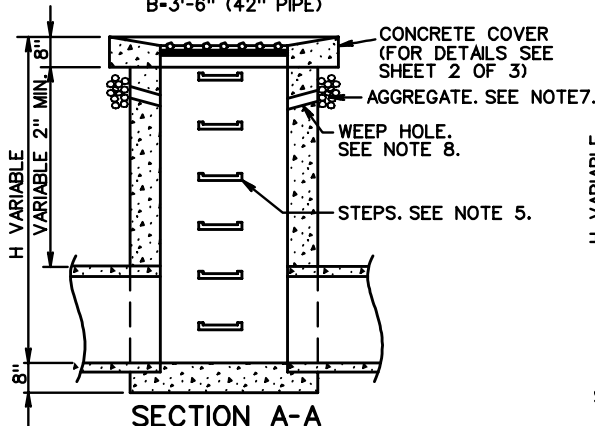

SECTION A-A
CAST IN PLACE
FOR USE WITH 12" TO 42" PIPES

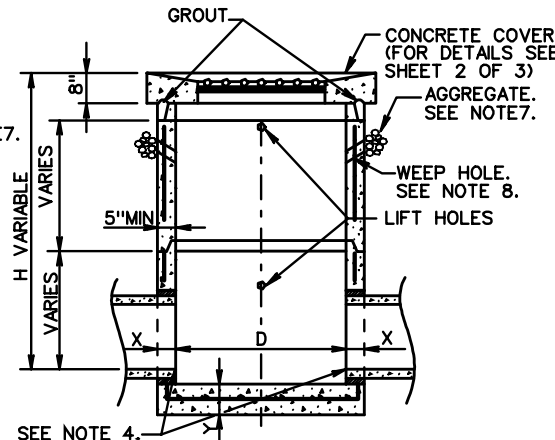

SECTION B-B
PRECAST

1. DEPTH OF INLET (H) TO BE SHOWN ON PLANS.
2. THE "H" DIMENSION SHOWN ON THE STANDARDS AND SPECIFIED ON THE PLANS WILL BE MEASURED FROM THE INVERT OF THE OUTFALL PIPE TO THE TOP OF THE STRUCTURE. PLAN "H" DIMENSIONS ARE APPROXIMATE ONLY FOR ESTIMATING PURPOSES AND THE ACTUAL DIMENSIONS SHALL BE DETERMINED BY THE CONTRACTOR FROM FIELD CONDITIONS. MAXIMUM DEPTH (H) TO BE 12'-8."
3. WHEN SPECIFIED ON THE PLANS THE INVERT IS TO BE SHAPED IN ACCORDANCE WITH STANDARD IS-1. THE COST OF FURNISHING AND PLACING ALL MATERIALS INCIDENTAL TO THE SHAPING IS TO BE INCLUDED IN THE BID PRICEN FOR THE STRUCTURE.
4. IN THE EVENT THE INVERT OF THE OUTFALL PIPE IS HIGHER THAN THE BOTTOM OF THE STRUCTURE, THE INVERT OF THE STRUCTURE SHALL BE SHAPED WITH CEMENT MORTAR TO PREVENT STANDING OR PONDING OF WATER IN THE STRUCTURE. THE COST OF FURNISHING AND PLACING ALL MATERIALS INCIDENTAL TO THE SHAPING IS TO BE INCLUDED IN THE BID PRICE FOR THE STRUCTURE.
5. STEPS ARE TO BE PROVIDED WHEN H IS 4'-0" OR GREATER. FOR DETAILS SEE STANDARD ST-1.
6. REINFORCED CONCRETE FOOTING MAY BE PRECAST OR CAST-IN-PLACE. TWO LIFTING HOOKS OF FABRICATORS DESIGN TO BE PROVIDED IN PRECAST FOOTING
7. 4" DEPTH AGGREGATE #68, #78, OR #8 X 6" WIDTH.
8. 3" DIAMETER WEEP HOLE WITH 12"X12" PLASTIC HARDWARE CLOTH 1/4" MESH OR GALVANIZED STEEL WIRE, MINIMUM WIRE DIAMETER 0.03" NUMBER 4 MESH HARDWARE CLOTH ANCHORED FIRMLY TO THE OUTSIDE OF THE STRUCTURE.

NOTES (CONT.)

15. DI-7-----NO GUTTER
DI-7A-----SINGLE GUTTER WHEN DROP INLET IS ON A GRADE.
DI-7B----- DOUBLE GUTTER WHEN DROP INLET IS IN A SAG BETWEEN TWO GRADES.
16. FOR DETAILS OF PRECAST DI-7 NOT SHOWN HEREON SEE PRECAST UNIT ASSEMBLY DIAGRAM, PAGE 103.01, FOR PRECAST GENERAL NOTES, PAGE 103.02 AND FOR APPLICABLE PRECAST BASE, RISER AND TOP DETAILS, PAGES 103.07 THRU 103.12.
17. GRATE BARS TO BE PARALLEL TO DITCH FLOW.

PIPE SIZE	12"	15"	18"	24"	30"	36"	42"
MINIMUM DEPTH H	2'-0"	2'-3/4"	2'-6/2"	3'-1"	3'-7/2"	4'-2"	4'-8/2"
CONCRETE CUBIC YARDS	.947	1.045	1.143	1.339	1.535	1.731	1.927

INCREMENT PER FOOT OF ADDITIONAL DEPTH (H) { = 0.362 CU. YDS. (12" - 36" PIPE)
= 0.410 CU. YDS. (42" PIPE)

9. THE TYPE OF INLET (PRECAST OR CAST IN PLACE), DETAILED HEREON, TO BE CONSTRUCTED, WILL BE AT THE OPTION OF THE CONTRACTOR.
10. FOR DETAILS OF CONCRETE COVER, COLLAR AND GRATE AND THE METHOD OF PLACING APPROACH GUTTER SEE SHEET 2 OF 3.
11. CAST-IN PLACE CONCRETE IS TO BE CLASS A3 (3000 PSI). PRECAST CONCRETE IS TO BE 4000 PSI.
12. CONCRETE QUANTITIES SHOWN ARE FOR INDICATED DEPTH (H) WITHOUT PIPES. THE AMOUNT DISPLACED BY PIPES MUST BE DEDUCTED TO OBTAIN TRUE QUANTITIES. FOR INLETS OF DIFFERENT DEPTHS ADD OR SUBTRACT THE APPROPRIATE CUBIC YARDS OF CONCRETE FOR EACH FOOT OF DEPTH.
13. PAVED DITCHES ARE TO BE TRANSITIONED TO MEET INLET GUTTER AS SHOWN IN STANDARD PG-2A.
14. PROVIDE SAFETY SLABS WHEN SPECIFIED ON THE PLANS.

RECOMMENDED MINIMUM HEIGHT CHART		
PIPE SIZE	H DIMENSION	
	CONC.	CORR. METAL
12"	2'-6"	2'-5"
15"	2'-9/4"	2'-8"
18"	3'-0/2"	2'-11"
21"	3'-3/4"	3'-2"
24"	3'-7"	3'-5"
27"	3'-10/4"	3'-8"
30"	4'-1/2"	3'-11"
33"	4'-4/4"	4'-2"
36"	4'-8"	4'-5"
42"	5'-2/2"	4'-11"

SPECIFICATION REFERENCE

241
503

STANDARD MEDIAN DROP INLET

12" TO 42" PIPE

VIRGINIA DEPARTMENT OF TRANSPORTATION

VDOT

ROAD AND BRIDGE STANDARDS

REVISION DATE

SHEET 1 OF 3

104.22

DETAILS OF CONCRETE COVER AND GRATE

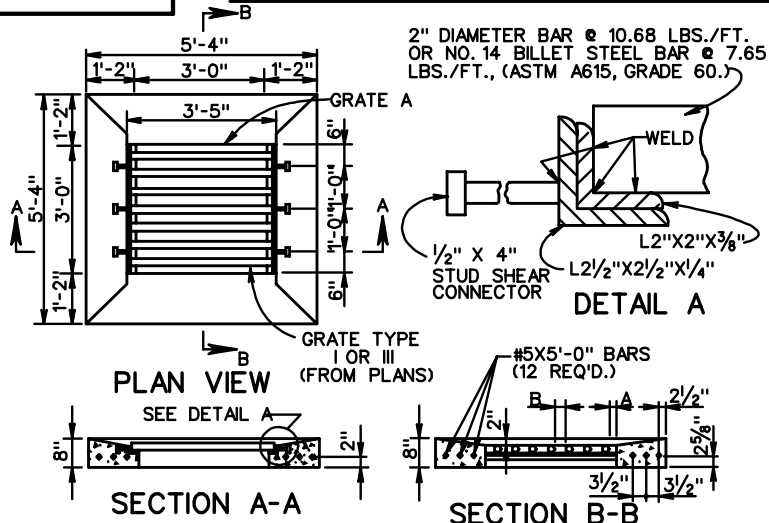

GRATE A:

BAR SPACING CHART		
GRATE TYPE	MAXIMUM DIMENSION	
I	1 1/2"	3"
III	1"	1"

APPROXIMATE QUANTITIES	
CONCRETE CLASS A3	REINFORCING STEEL
0.423 C. Y.	63 LBS.

NOTES

- GRATE A IS TO BE UTILIZED IN LOCATIONS NOT NORMALLY SUBJECT TO TRAFFIC.
- GRATE B IS TO BE UTILIZED IN LOCATIONS NORMALLY SUBJECT TO TRAFFIC.
- FOR DETAILS OF LOAD CARRYING GRATE (GRATE B), SEE T-DI-7, SHEET 103.0B.
- CONCRETE COVER AND GRATE ARE TO BE FURNISHED AS A SINGLE UNIT. OUTSIDE DIMENSIONS OF GRATE TO BE 3'-4" X 2'-11 1/2" (GRATE A) OR 3'-4" X 2'-11 1/2" (GRATE B).
- ALTERNATE METHODS OF ANCHORING ANGLE IRON WILL BE ACCEPTABLE IF APPROVED BY THE ENGINEER.
- GRATE AND COLLAR ARE TO BE GALVANIZED.
- CONCRETE COVER MAY BE PRECAST OR CAST IN PLACE.
- CONCRETE TO BE CLASS A3 IF CAST IN PLACE. 4000 PSI IF PRECAST.
- GRATE BARS TO BE PARALLEL TO DITCH FLOW.

DETAILS OF GUTTER AND METHOD OF PLACEMENT

NOTES

- DI-7 NO GUTTERS.
DI-7A NO GUTTER IN ONE DIRECTION.
DI-7B GUTTER IN BOTH DIRECTIONS.
- JOINTS BETWEEN GUTTERS AND CONCRETE COVER ARE TO BE DOWELED WITH #4 X 8" SMOOTH RODS @ APPROX. 12" C-C TO PREVENT SETTLEMENT. IN LIEU OF DOWELS A 2" X 4" NOTCH MAY BE PROVIDED. SEE STANDARD T-DI-3, 4 ALTERNATE DESIGN.
- VARIABLE 2:1 OR FLATTER.
- DITCH GRADE MUST BE ADJUSTED TO MEET DIFFERENCE IN ELEVATION. SEE LONGITUDINAL SECTION.
- IF DEPTH (D) BECOMES LESS THEN 4", LENGTH OF WINGS ARE TO BE EXTENDED AS DIRECTED BY THE ENGINEER.
- CURTAIN WALL TO BE LOCATED AT THE END OF THE PAVED DITCH SECTIONS OF THE DI-7A & DI-7B THAT ARE NOT ABUTTED BY OTHER DRAINAGE.
- IF NORMAL DITCH GRADE IS TOO FLAT TO ALLOW FOR ADJUSTED GRADE TO INLET, A SPECIAL GUTTER DETAIL WILL BE REQUIRED ON PLANS.

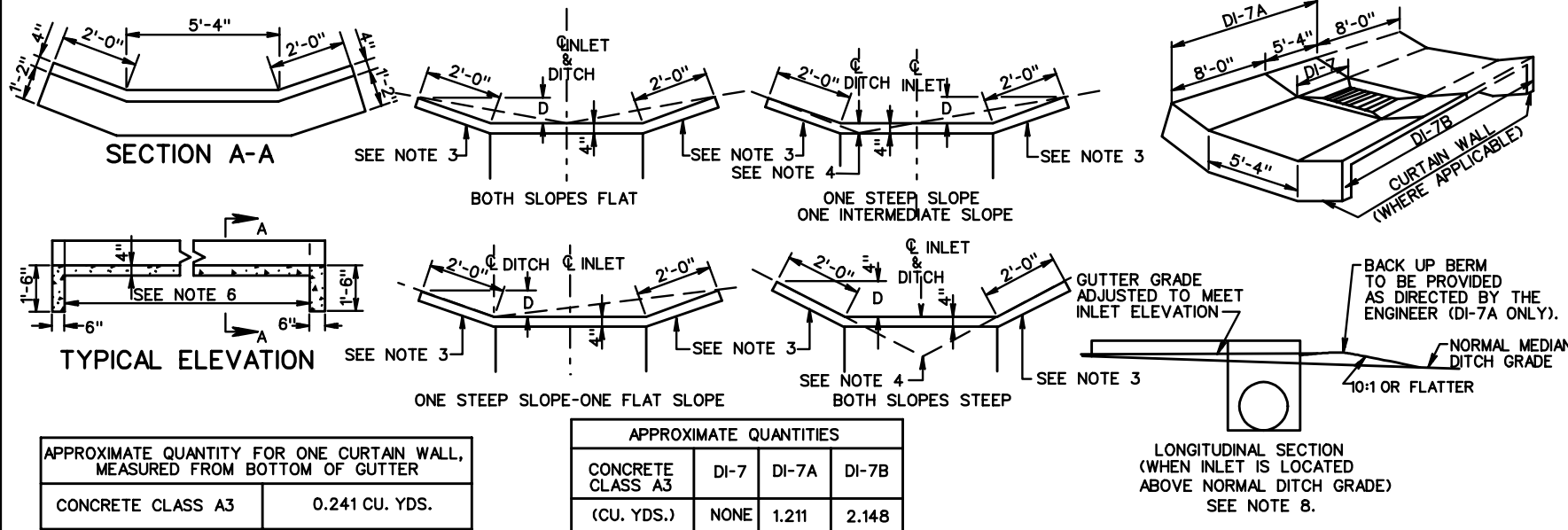

APPROXIMATE QUANTITY FOR ONE CURTAIN WALL, MEASURED FROM BOTTOM OF GUTTER	
CONCRETE CLASS A3	0.241 CU. YDS.

APPROXIMATE QUANTITIES			
CONCRETE CLASS A3 (CU. YDS.)	DI-7	DI-7A	DI-7B
	NONE	1.211	2.148



ROAD AND BRIDGE STANDARDS

SHEET 2 OF 3

REVISION DATE

104.23

STANDARD MEDIAN DROP INLET

12" TO 42" PIPE

VIRGINIA DEPARTMENT OF TRANSPORTATION

SPECIFICATION REFERENCE

241
503

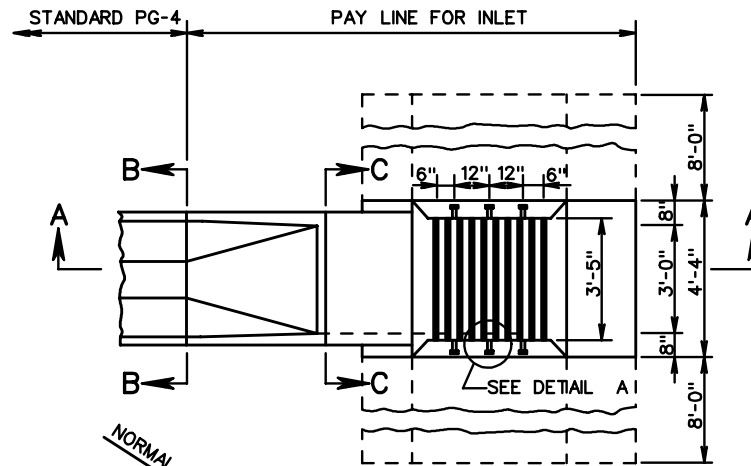

NOTES

1. APRON IS TO BE CONSTRUCTED TO A DEPTH OF 1'-0" ON BACK SLOPE SIDE OF INLET (DI-7). ON ROADWAY SIDE, THE DEPTH IS TO BE 1'-0" OR TO THE SHOULDER ELEVATION, WHICHEVER IS LESSER.
2. ALTERNATE METHODS OF ANCHORING ANGLE IRON WILL BE ACCEPTABLE IF APPROVED BY THE ENGINEER.
3. COLLAR AND GRATE ARE TO BE GALVANIZED IN ACCORDANCE WITH THE SPECIFICATIONS.
4. OUTSIDE DIMENSIONS OF GRATE ARE TO BE 3'-4" X 2'-11 3/4".
5. ALL CONCRETE IS TO BE CLASS A3.
6. NORMAL DITCH IS TO BE TRANSITIONED TO TIE SMOOTHLY INTO GUTTER. DITCH GRADE IS TO BE ADJUSTED AS NECESSARY TO MEET GRADE ELEVATION.
7. QUANTITIES SHOWN ARE BASED ON DEPTH H = 5'-0".
8. THE AMOUNT OF CONCRETE DISPLACED BY PIPES MUST BE DEDUCTED TO OBTAIN TRUE QUANTITIES. FOR EACH FOOT OF DIFFERENCE IN DEPTH H ADD OR SUBTRACT INCREMENT AS SHOWN.
9. SEE STANDARD DI-7, DI-7A AND DI-7B FOR DETAILS AND DIMENSIONS NOT SHOWN HEREON.
10. GRATE BARS ARE TO BE INSTALLED SO THEY WILL BE ALIGNED PARALLEL TO THE DITCH FLOW.

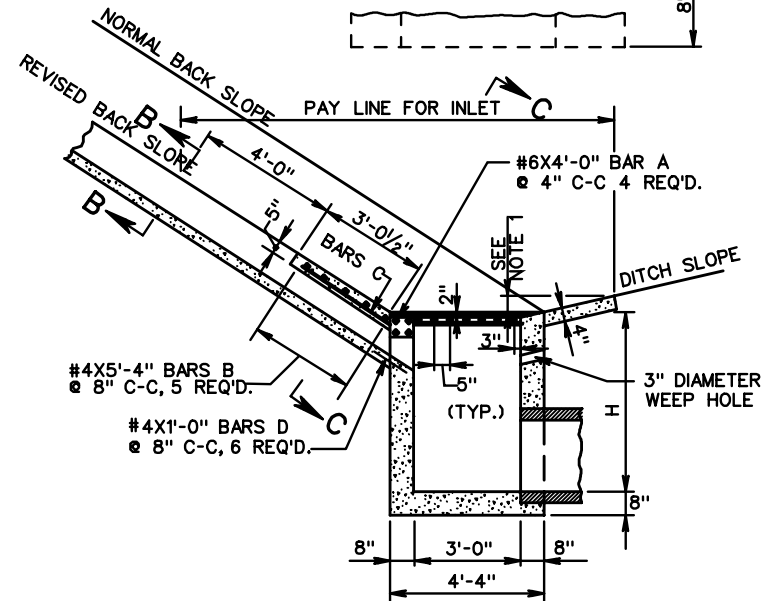

APPROXIMATE QUANTITIES	
CLASS A3 CONCRETE	REINFORCING STEEL
CU. YDS.	LBS.
4.091	60

INCREMENT PER FOOT OF DEPTH (H) = 0.362 CU. YDS.
 CONCRETE TO BE ADDED WHEN DOUBLE GUTTER IS REQ'D. = 1.112 CU. YDS.

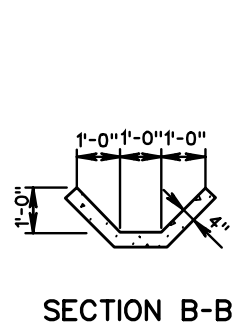

SECTION B-B

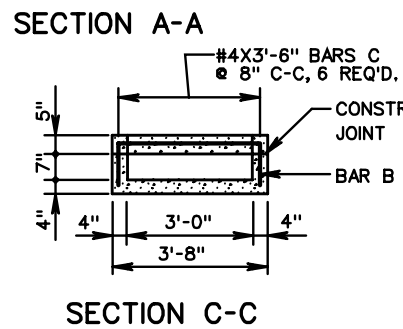

SECTION C-C

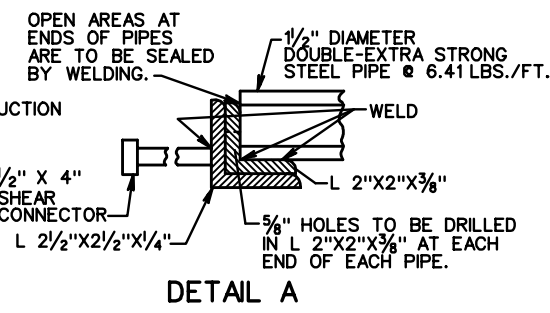

DETAIL A

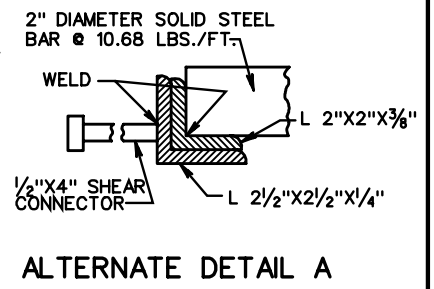

ALTERNATE DETAIL A

SPECIFICATION REFERENCE
502

STANDARD DI-7, 7A OR 7B WITH FLUME CONNECTION
 12" TO 36" PIPE
 VIRGINIA DEPARTMENT OF TRANSPORTATION

VDOT	
ROAD AND BRIDGE STANDARDS	
REVISION DATE	SHEET 3 OF 3
104.24	

NOTES

1. PRECAST PIPE PLUG SHALL BE SET IN FRESH MORTAR.
2. PRECAST PLUG SHALL COMFORM TO PIPE MANUFACTURER'S JOINT DESIGN AND SHALL HAVE A MINIMUM THICKNESS NOT LESS THAN PIPE WALL THICKNESS.
3. THIS INLET IS TO BE USED ONLY IN LOCATIONS NOT SUBJECT TO TRAFFIC.
4. FRAME IS TO BE SECURELY MORTARED TO TEE SECTION.
5. FRAME AND GRATE SHALL BE GRAY IRON, ASTM A48, CLASS 30S.
6. THE PRECAST TEE UNIT IS TO COMFORM TO THE REQUIREMENTS OF AASHTO M170 FOR 15" CLASS III REINFORCED CONCRETE PIPE.
7. IF A PRECAST PLUG IS NEEDED, THE COST OF THE PRECAST PLUG SHALL BE INCLUDED IN THE PRICE BID FOR DI-9.

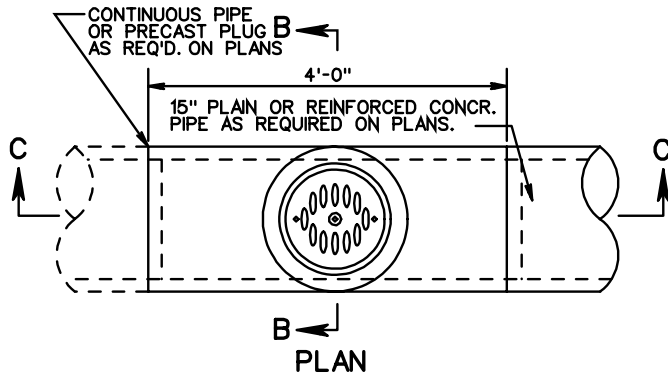

SECTION B-B

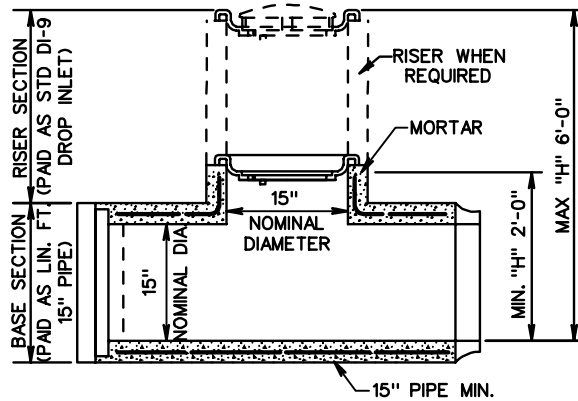
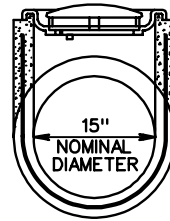

SECTION C-C

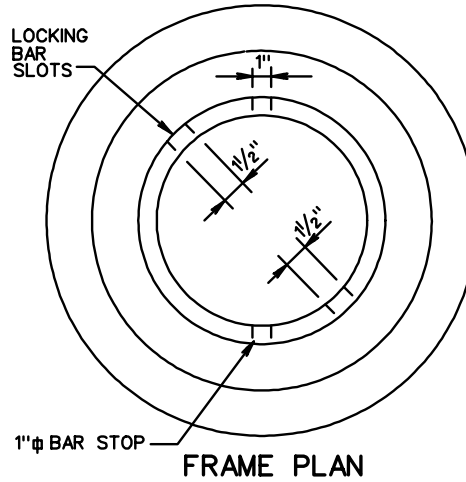

FRAME PLAN

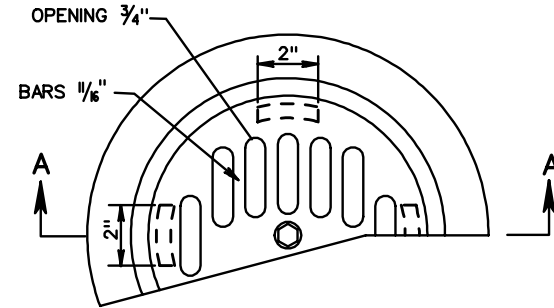

PART PLAN FRAME & GRATE

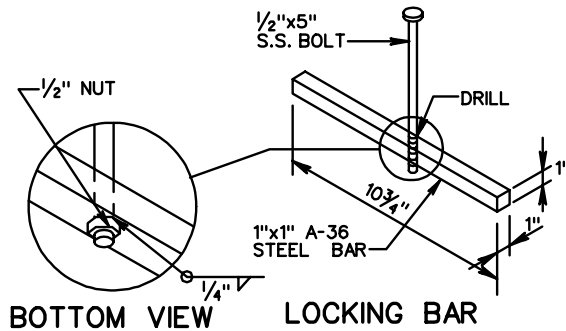

BOTTOM VIEW LOCKING BAR

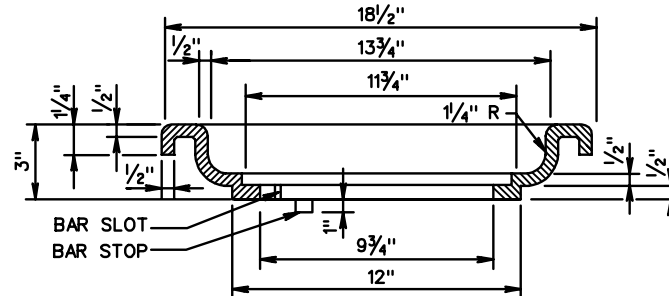

SECTION A-A FRAME

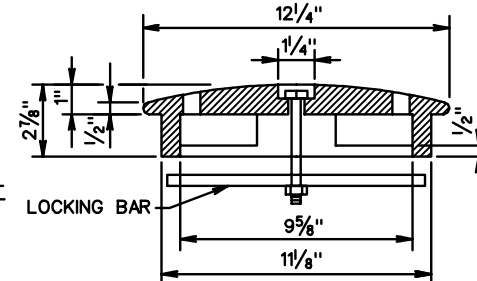

SECTION A-A GRATE



ROAD AND BRIDGE STANDARDS

SHEET 1 OF 1

REVISION DATE

104.25

15" PIPE TEE SECTION DROP INLET

VIRGINIA DEPARTMENT OF TRANSPORTATION

SPECIFICATION REFERENCE

233
302

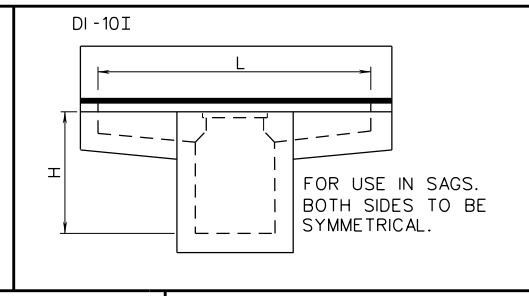
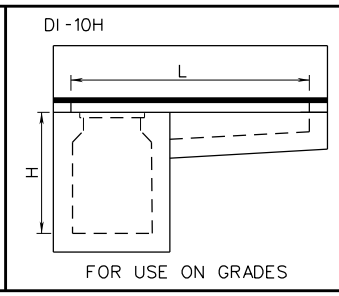
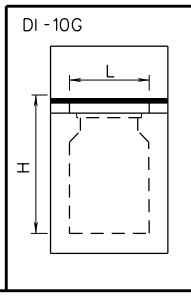
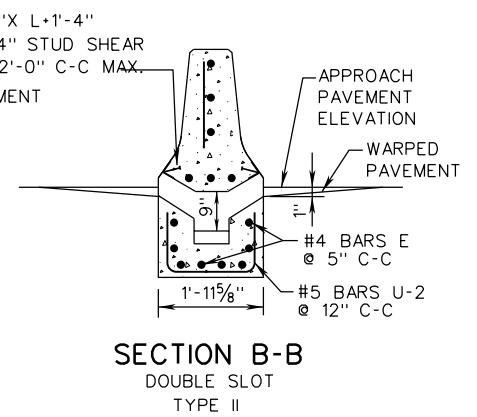
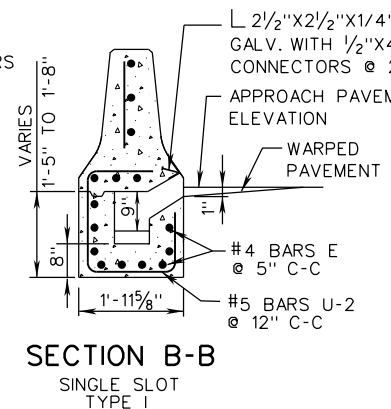
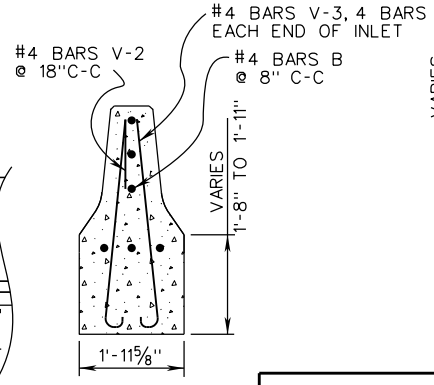
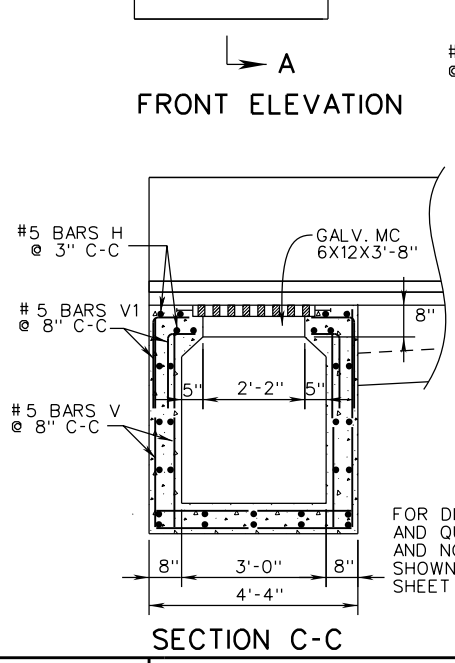
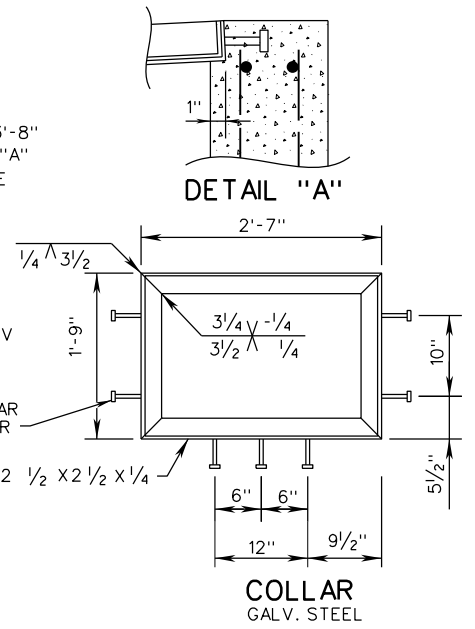
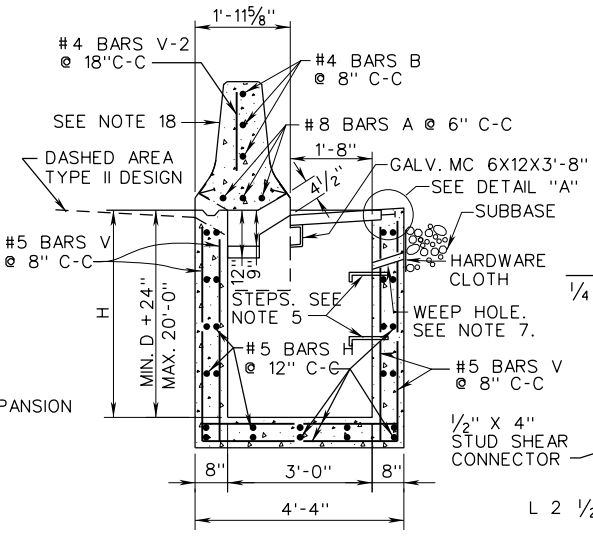
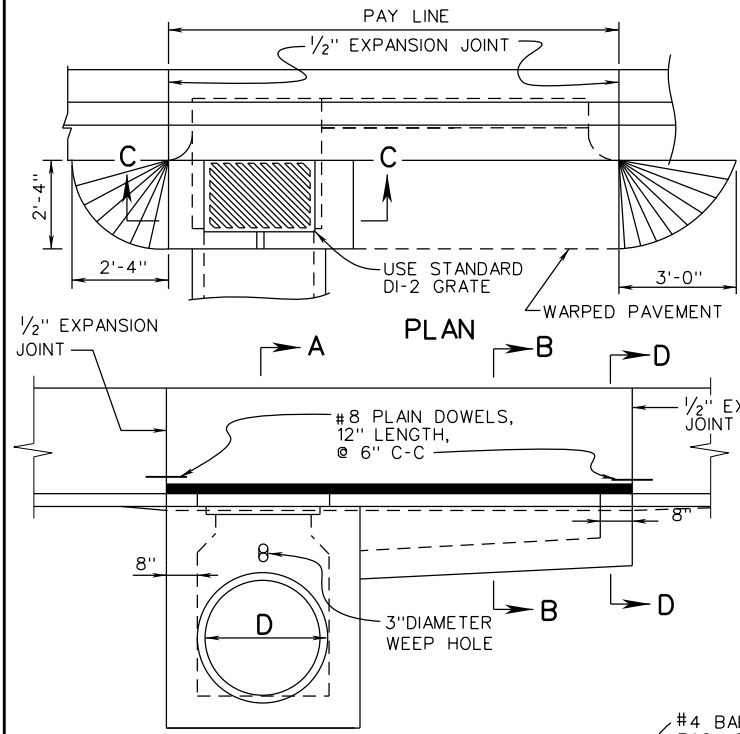

SPECIFICATION REFERENCE
233 302

CONCRETE MEDIAN BARRIER DROP INLET (WITH MB-7D)
 12" - 36" PIPE: DEPTH (H)=20'-0" MAX.
 VIRGINIA DEPARTMENT OF TRANSPORTATION

VDOT ROAD AND BRIDGE STANDARDS	
REVISION DATE 01/13	SHEET 1 OF 2 104.26

TABLE OF QUANTITIES

REINFORCING STEEL

TYPE	L	CONCRETE		BARS A	BARS B	BARS E	BARS H	BARS U-1	BARS U-2	BARS V	BARS V-1	BARS V-2	BARS V-3	TYPE I	TYPE II										
		TYPE I	TYPE II																						
		Ft.	Cu. Yd.													Cu. Yd.	No.	Ln.*Ft.	No.	Ln.*Ft.	No.	Ln.*Ft.	No.	Ln.*Ft.	No.
DI-10G	3'	2.08	2.05	3	4'-0"	3	4'-0"	-	-	38	4'-0"	-	-	-	-	48	3'-4"	12	2'-6"	3	2'-4"	8	4'-5"	426	426
	4'	2.26	2.25	3	5'-0"	3	5'-0"	8	1'-4"	38	4'-0"	2	5'-2" to 5'-8"	2	3'-1" to 3'-7"	48	3'-4"	12	2'-6"	4	2'-4"	8	4'-5"	456	451
	6'	2.65	2.63	3	7'-0"	3	7'-0"	8	3'-4"	38	4'-0"	4	5'-2" to 5'-8"	4	3'-1" to 3'-7"	48	3'-4"	12	2'-6"	5	2'-4"	8	4'-5"	499	490
	8'	3.04	3.02	3	9'-0"	3	9'-0"	8	5'-4"	38	4'-0"	6	5'-2" to 5'-8"	6	3'-1" to 3'-7"	48	3'-4"	12	2'-6"	7	2'-4"	8	4'-5"	544	531
	10'	3.43	3.40	3	11'-0"	3	11'-0"	8	7'-4"	38	4'-0"	8	5'-2" to 5'-8"	8	3'-1" to 3'-7"	48	3'-4"	12	2'-6"	8	2'-4"	8	4'-5"	588	571
DI-10H	12'	3.82	3.78	3	13'-0"	3	13'-0"	8	9'-4"	38	4'-0"	10	5'-2" to 5'-8"	10	3'-1" to 3'-7"	48	3'-4"	12	2'-6"	9	2'-4"	8	4'-5"	631	610
	14'	4.21	4.16	3	15'-0"	3	15'-0"	8	11'-4"	38	4'-0"	12	5'-2" to 5'-8"	12	3'-1" to 3'-7"	48	3'-4"	12	2'-6"	11	2'-4"	8	4'-5"	677	650
	16'	4.60	4.54	3	17'-0"	3	17'-0"	8	13'-4"	38	4'-0"	14	5'-2" to 5'-8"	14	3'-1" to 3'-7"	48	3'-4"	12	2'-6"	12	2'-4"	8	4'-5"	720	690
	18'	5.00	4.94	3	19'-0"	3	19'-0"	8	15'-4"	38	4'-0"	16	5'-2" to 5'-8"	16	3'-1" to 3'-7"	48	3'-4"	12	2'-6"	13	2'-4"	8	4'-5"	764	729
	20'	5.39	5.32	3	21'-0"	3	21'-0"	8	17'-4"	38	4'-0"	18	5'-2" to 5'-8"	18	3'-1" to 3'-7"	48	3'-4"	12	2'-6"	15	2'-4"	8	4'-5"	809	770
	6'	2.65	2.63	3	7'-0"	3	7'-0"	16	2'-0"	38	4'-0"	6	5'-2" to 5'-8"	6	3'-1" to 3'-7"	48	3'-4"	12	2'-6"	5	2'-4"	8	4'-5"	514	501
	8'	3.04	3.02	3	9'-0"	3	9'-0"	16	3'-0"	38	4'-0"	8	5'-2" to 5'-8"	8	3'-1" to 3'-7"	48	3'-4"	12	2'-6"	7	2'-4"	8	4'-5"	559	542
DI-10 I	10'	3.43	3.40	3	11'-0"	3	11'-0"	16	4'-0"	38	4'-0"	10	5'-2" to 5'-8"	10	3'-1" to 3'-7"	48	3'-4"	12	2'-6"	8	2'-4"	8	4'-5"	603	581
	12'	3.82	3.78	3	13'-0"	3	13'-0"	16	5'-0"	38	4'-0"	12	5'-2" to 5'-8"	12	3'-1" to 3'-7"	48	3'-4"	12	2'-6"	9	2'-4"	8	4'-5"	646	620
	14'	4.21	4.16	3	15'-0"	3	15'-0"	16	6'-0"	38	4'-0"	14	5'-2" to 5'-8"	14	3'-1" to 3'-7"	48	3'-4"	12	2'-6"	11	2'-4"	8	4'-5"	691	661
	16'	4.60	4.54	3	17'-0"	3	17'-0"	16	7'-0"	38	4'-0"	16	5'-2" to 5'-8"	16	3'-1" to 3'-7"	48	3'-4"	12	2'-6"	12	2'-4"	8	4'-5"	735	700
	18'	5.00	4.94	3	19'-0"	3	19'-0"	16	8'-0"	38	4'-0"	18	5'-2" to 5'-8"	18	3'-1" to 3'-7"	48	3'-4"	12	2'-6"	13	2'-4"	8	4'-5"	778	739
	20'	5.39	5.32	3	21'-0"	3	21'-0"	16	9'-0"	38	4'-0"	20	5'-2" to 5'-8"	20	3'-1" to 3'-7"	48	3'-4"	12	2'-6"	15	2'-4"	8	4'-5"	824	780

NOTES

1. DEPTH OF INLET (H) TO BE SHOWN ON PLANS.
2. THE "H" DIMENSION SHOWN ON THE STANDARDS AND SPECIFIED ON THE PLANS WILL BE MEASURED FROM THE INVERT OF THE OUTFALL PIPE TO THE TOP OF THE STRUCTURE. PLAN "H" DIMENSIONS ARE APPROXIMATE ONLY FOR ESTIMATING PURPOSES AND THE ACTUAL DIMENSIONS SHALL BE DETERMINED BY THE CONTRACTOR FROM FIELD CONDITIONS.
3. WHEN SPECIFIED ON THE PLANS THE INVERT IS TO BE SHAPED IN ACCORDANCE WITH STANDARD IS-1. THE COST OF FURNISHING AND PLACING ALL MATERIALS INCIDENTAL TO THE SHAPING IS TO BE INCLUDED IN THE BID PRICE FOR STRUCTURE.
4. IN THE EVENT THE INVERT OF THE OUTFALL PIPE IS HIGHER THAN THE BOTTOM OF THE STRUCTURE, THE INVERT OF THE STRUCTURE SHALL BE SHAPED WITH CEMENT MORTAR TO PREVENT STANDING OR PONDING OF WATER IN THE STRUCTURE. THE COST OF FURNISHING AND PLACING ALL MATERIALS INCIDENTAL TO THE SHAPING IS TO BE INCLUDED IN THE BID PRICE FOR THE STRUCTURE.
5. STEPS ARE TO BE PROVIDED WHEN H IS 4'-0" OR GREATER. FOR DETAILS SEE STANDARD ST-1.
6. THIS ITEM MAY BE PRECAST OR CAST-IN-PLACE.
7. 3" DIAMETER WEEP HOLE TO BE LOCATED TO DRAIN SUBBASE MATERIAL. WEEP HOLE WITH 12"X12" PLASTIC HARDWARE CLOTH 1/4" MESH OR GALVANIZED STEEL WIRE, MINIMUM WIRE DIAMETER 0.03", NUMBER 4 MESH HARDWARE CLOTH ANCHORED FIRMLY TO THE OUTSIDE OF THE STRUCTURE.
8. ALL REINFORCING STEEL SHALL HAVE A MIN. COVER OF 2".
9. ALL REINFORCING STEEL TO BE CUT CLEAR OF ALL OPENINGS BY 2".
10. CAST-IN PLACE CONCRETE IS TO BE CLASS A3 (3000 PSI). PRECAST CONCRETE IS TO BE 4000 PSI.
11. LENGTH OF SLOT (L) WILL, IN EVERY CASE, BE SHOWN ON PLANS.
12. CONCRETE QUANTITIES SHOWN ARE FOR DEPTH (H) OF 3'-0" WITHOUT PIPES. THE AMOUNT DISPLACED BY PIPES MUST BE DEDUCTED TO OBTAIN TRUE QUANTITIES. FOR INLETS OF DIFFERENT DEPTHS ADD OR SUBTRACT 0.36 CUBIC YARDS OF CONCRETE FOR EACH FOOT OF DEPTH. AND 84 LBS. OF REINFORCING STEEL.
13. LENGTH OF ANGLE IRON AS SHOWN ON SHEET 1 OF 2 IS TO BE L +16" AT 4.10 LBS./FT..
14. * DENOTES LENGTH OF ONE (1) BAR.
15. GRATE TO BE INSTALLED SO SLOTS WILL DIRECT WATER TOWARD THE INLET THROAT. GRATE MUST BE REVERSIBLE (RIGHT HAND GRATE IS SHOWN).
16. PROVIDE SAFETY SLABS WHEN SPECIFIED ON PLANS.
17. FOR DETAILS AND DIMENSIONS NOT SHOWN FOR MEDIAN BARRIER SEE STANDARD MB-7D.
18. QUANTITIES INCLUDE MB-7D.



ROAD AND BRIDGE STANDARDS

CONCRETE MEDIAN BARRIER DROP INLET (WITH MB-7D)

SPECIFICATION
REFERENCE

SHEET 2 OF 2

REVISION DATE

12" - 36" PIPE: DEPTH (H)-20'-0" MAX.

233
302

104.27

VIRGINIA DEPARTMENT OF TRANSPORTATION

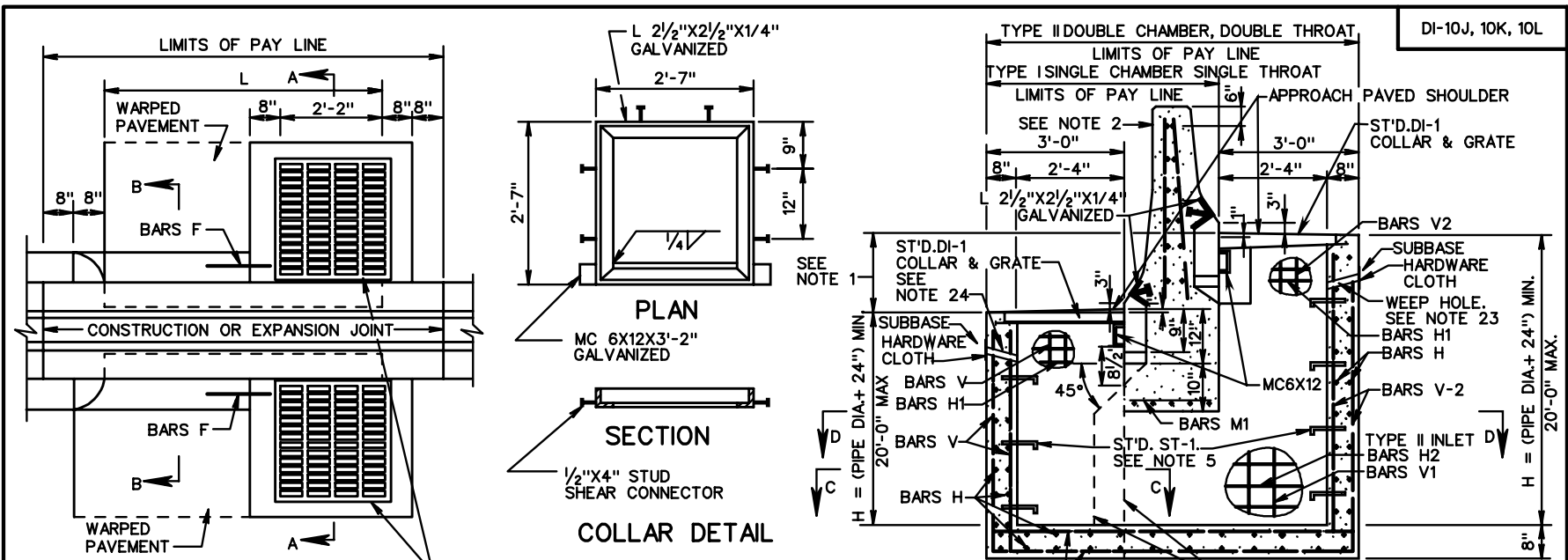

PLAN VIEW
 COLLAR DETAIL
 SECTION A-A

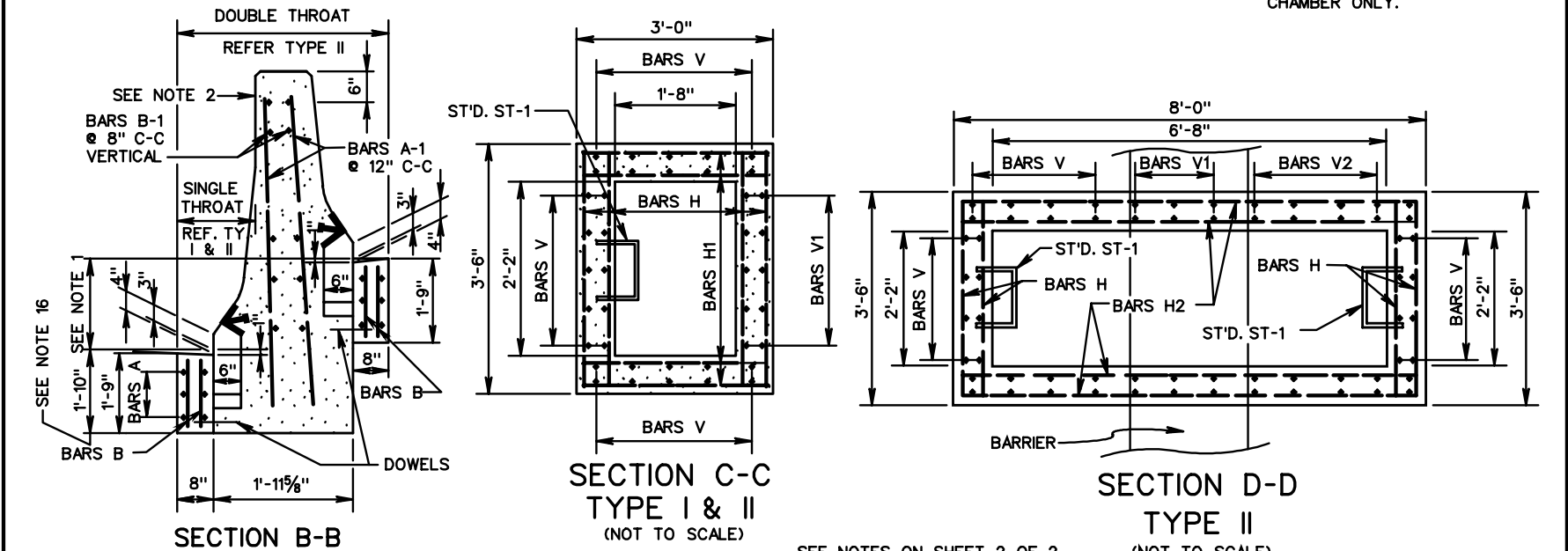

SPECIFICATION REFERENCE 233 302	CONCRETE MEDIAN BARRIER DROP INLET (WITH MB-8A) 12" - 24" PIPE: DEPTH (H) - 20' MAX VIRGINIA DEPARTMENT OF TRANSPORTATION	VDOT ROAD AND BRIDGE STANDARDS REVISION DATE SHEET 1 OF 2 104.28
---	--	--

SEE NOTES ON SHEET 2 OF 2 (NOT TO SCALE)

TYPE I & III INLET

REINFORCING STEEL				
MARK	SIZE	NO.	LENGTH	SPACE
A SEE NOTE 9	#4	6 SEE NOTE 7	L - 2'-6" SEE NOTE 8	AS SHOWN
A-1 SEE NOTE 11	#4	(2xL)+2	4'-0"	12
B SEE NOTE 9	#3	2x(L-4)	1'-1"	12
B-1 SEE NOTE 11	#4	9	L + (2'-4")	8
DOWELS	#4	SEE NOTE 6	1'-0"	6
F SEE NOTE 9	#5	3 SEE NOTE 10	1'-6"	6
H	#5	(4xH) + 10	3'-2"	12
H1	#5	(4xH) + 8	2'-8"	10

TYPE - II INLET

REINFORCING STEEL				
MARK	SIZE	NO.	LENGTH	SPA.
A-1	#4	(2xL) 2	4'-0"	12"
B-1	#4	9	L+(2'-4")	8"
H-2	#5	16 SEE NOTE 12	7'-8"	10"
V-1	#4	12	H - (1'-2")	8"
V-2	#4	30	LENGTH = H	8"
A SEE NOTE 15	#4	12 SEE NOTE 14	L - (2'-6") SEE NOTE 8	AS SHOWN
B SEE NOTE 15	#3	4(L-4)	1'-1"	12"
DOWELS	#4	DOUBLE NO. SHOWN FOR TYPE I	1'-0"	6"
F SEE NOTE 15	#5	6 SEE NOTE 13	1-6"	6"
H	#5	(4 + H) + 8	3'-2"	12"
H-1	#5	(4 + H) + 16	2'-8"	10"
V	#4	30	LENGTH = H	8"
M-1	#5	5	3'-2"	5"
M	#4	4	1'-8"	12"

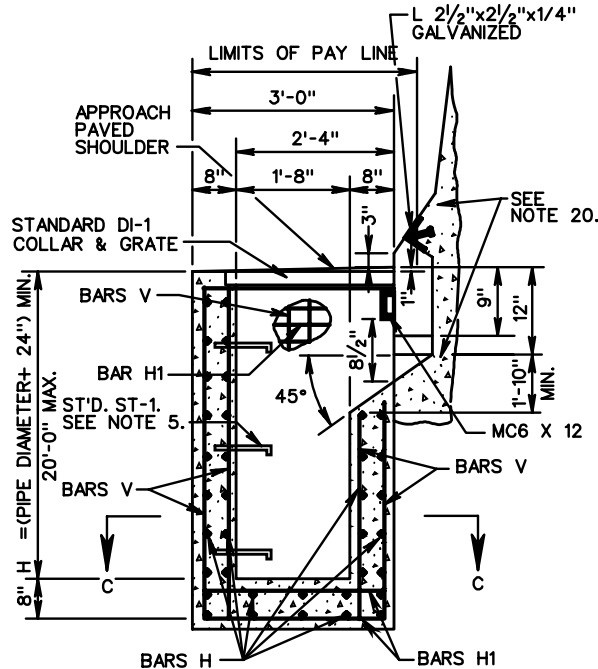

FOR USE ADJACENT TO WALL OR BARRIER WITH SAFETY SHAPE (TYPE III)

- TYPE I DENOTES INLET WITH SINGLE THROAT AND CHAMBER
TYPE II DENOTES INLET WITH DOUBLE THROAT AND CHAMBER.
TYPE III DENOTES INLET WITH SINGLE THROAT AND CHAMBER ADJACENT TO WALL OR BARRIER.
- MAXIMUM PIPE SIZE IS 24" DIAMETER.
- 3" DIAMETER WEEP HOLE TO BE LOCATED TO DRAIN SUBBASE MATERIAL. WEEP HOLE WITH 12" X 12" PLASTIC HARDWARE CLOTH 1/4" MESH OR GALV. STEEL WIRE, MIN. WIRE DIAMETER 0.03", #4 MESH HARDWARE CLOTH ANCHORED FIRMLY TO OUTSIDE OF THE STRUCTURE.
- PROVIDE SAFETY SLABS WHEN SPECIFIED ON THE PLANS.
- WHEN SPECIFIED ON THE PLANS, THE INVERT IS TO BE SHAPED IN ACCORDANCE WITH THE STANDARD IS-1. THE COST OF FURNISHING AND PLACING ALL MATERIALS INCIDENTAL TO THE SHAPING IS TO BE INCLUDED IN THE BID PRICE FOR THE STRUCTURE.

NOTES

- VARIABLES GREATER THAN:
0' TO 18" MAX. TYPE II CHAMBER.
4" TO 3' MAX. TYPE I CHAMBER.
- FOR DETAILS AND DIMENSIONS NOT SHOWN FOR MEDIAN BARRIER, SEE STANDARD MB-8A.
- GALVANIZED MC-6 X 12 IS TO BE WELDED UNDER THE COLLAR AND EXTENDED INTO SIDEWALLS TO WITHIN 2" OF OUTSIDE FACE.
- ALL REINFORCING BARS ARE TO BE GRADE 60 STEEL WITH MIN. OF 1/2" CONCRETE COVER. ANY BAR IN CONFLICT WITH PIPE SHELL AND/OR TOP SLAB OPENING ARE TO BE FIELD CUT TO PROVIDE THE REQUIRED COVER.
- DO NOT LOCATE STANDARD ST-1 STEPS ON CHAMBER WALLS THAT HAVE PIPES WHEN POSSIBLE.
- 8 DOWELS REQUIRED FOR DI-10L, MIN. L = 7'-0". ADD 2 DOWELS FOR EACH ADDITIONAL FOOT.
4 DOWELS REQUIRED FOR DI-10K, MIN. L = 4'-0". ADD 2 DOWELS FOR EACH ADDITIONAL FOOT.
- 12 BARS A REQUIRED FOR DI-10L.
- LENGTH OF BARS A, DI-10L = $\frac{L - (2'-6")}{2}$
- DO NOT USE WITH DI-10J.
- USE 6 BARS F FOR DI-10L TYPE I
- DO NOT USE WITH TYPE III.
- ADD 4 ADDITIONAL BARS FOR EACH EXTRA FOOT OF DEPTH.
- USE 12 BARS F FOR DI-10L TYPE II.
- 24 BARS A ARE REQUIRED FOR DI-10L.
- DO NOT USE WITH DI-10J.
- A MINIMUM 22" FOOTING DEPTH IS REQUIRED FOR FORMING THE INLET SLOT. SEE PLANS FOR LENGTH "L".
- REFER TO PLANS FOR STRUCTURE LOCATIONS, DATA AND DIMENSIONS.
- REFER TO PLANS FOR LOCATIONS OF PIPES AND INVERTS.
- FOR TYPE III, COST OF ACCOMMODATION OF INLET THROAT IS TO BE INCLUDED IN COST OF WALL BARRIER.
- FOR TYPE III, SEE WALL PLANS FOR WALL FOOTING DETAILS.

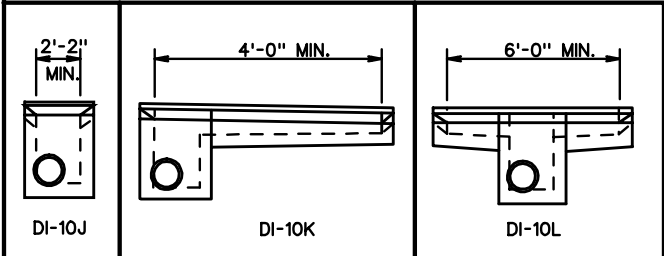

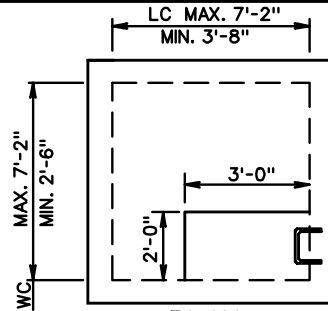

PLAN
(SLOT REMOVED)

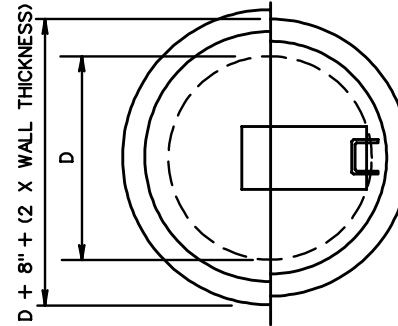

PLAN
(SLOT REMOVED)

X DIM.	DEPTH
8"	0' TO 10'
12"	10' TO 16'
16"	16' TO 25'

Y DIM.	DEPTH
5"	0' TO 12'
10"	12' TO 25'

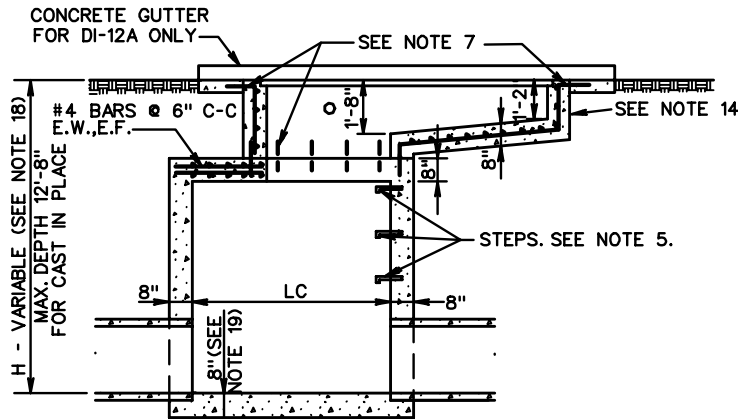

SECTION
(CAST IN PLACE)

MAXIMUM DEPTH: UNLIMITED, 60" MINIMUM DIAMETER.

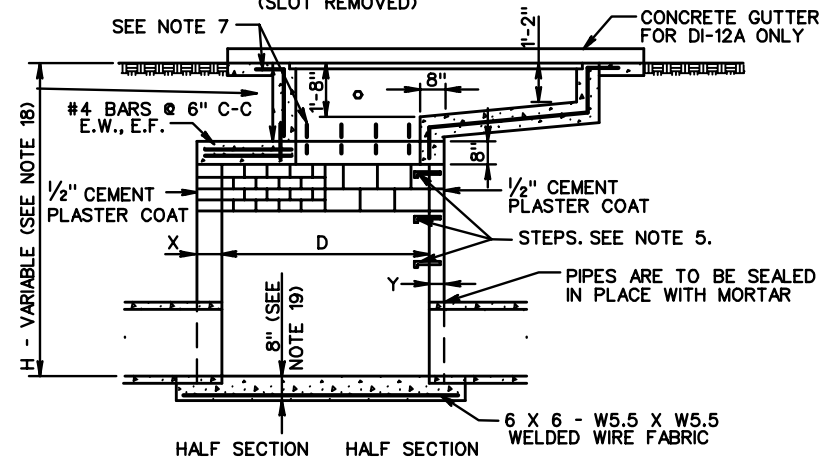

BRICK CONCRETE BLOCK

NOTES

- USE OF INLET RESTRICTED TO NON-VEHICULAR LOCATIONS.
- DEPTH OF INLET (H) AND LENGTH (L) TO BE SHOWN ON PLANS.
- THE "H" DIMENSION SHOWN ON THE STANDARDS AND SPECIFIED ON THE PLANS WILL BE MEASURED FROM THE INVERT OF THE OUTFALL PIPE TO THE TOP OF THE STRUCTURE.
- WHEN SPECIFIED ON THE PLANS THE INVERT IS TO BE SHAPED IN ACCORDANCE WITH STANDARD IS-1. THE COST OF FURNISHING AND PLACING ALL MATERIALS INCIDENTAL TO THE SHAPING IS TO BE INCLUDED IN THE BID PRICE FOR THE STRUCTURE.
- IN THE EVENT THE INVERT OF THE OUTFALL PIPE IS HIGHER THAN THE BOTTOM OF THE STRUCTURE, THE INVERT OF THE STRUCTURE SHALL BE SHAPED WITH CEMENT MORTAR TO PREVENT STANDING OR PONDING OF WATER IN THE STRUCTURE. THE COST OF FURNISHING AND PLACING ALL MATERIALS INCIDENTAL TO THE SHAPING IS TO BE INCLUDED IN THE BID PRICE FOR THE STRUCTURE.
- STEPS ARE TO BE PROVIDED WHEN H IS 4'-0" OR GREATER. FOR DETAILS SEE STANDARD ST-1.
- CHAMBER MAY BE PRECAST. SEE STANDARD 103.10 FOR DETAILS.
- # 4 DOWELS 12" LONG SPACED AT 12" C-C ALL SIDES.
- FOOTING MAY BE ROUND OR SQUARE IN SHAPE. KEY IS TO BE 1" DEEP X WALL THICKNESS + 1".
- ALL REINFORCING STEEL SHALL HAVE A MIN. COVER OF 2".
- ALL REINFORCING STEEL TO BE CUT CLEAR OF ALL OPENINGS BY 2".
- CAST-IN PLACE CONCRETE IS TO BE CLASS A3 (3000 PSI). PRECAST CONCRETE IS TO BE 4000 PSI.
- ALL REINFORCING BARS TO BE #4.
- GRATE BARS TO BE INSTALLED SO THEY WILL BE ALIGNED PARALLEL TO DITCH FLOW.
- FOR DETAILS OF CONCRETE SLOT, COLLAR AND GRATE, AND METHOD OF PLACING APPROACH GUTTER SEE SHEET 2 OF 3.
- PAVED DITCHES ARE TO BE TRANSITIONED TO MEET INLET GUTTER AS SHOWN IN ST'D. PG-2A.
- QUANTITIES SHOWN ARE FOR INLETS WITHOUT PIPES. PIPE DISPLACEMENTS MUST BE DEDUCTED TO OBTAIN TRUE QUANTITIES. SEE SHEET 3 OF 3 FOR QUANTITIES.
- PROVIDE SAFETY SLABS WHEN SPECIFIED ON THE PLANS.
- SEE TABULATION CHART ON SHEET 3 OF 3 FOR MINIMUM DEPTH (H).
- 10" THICK SLAB FOR PIPE SIZES 60" TO 72" IN DIAMETER.
- THE TYPE OF INLET DETAILED HEREON TO BE CONSTRUCTED WILL BE AT THE OPTION OF THE CONTRACTOR.
- DI-12 NO GUTTER.
DI-12A PERIPHERAL GUTTER.

SPECIFICATION REFERENCE

233
302

**MULTIGRATE DROP INLET
FOR PIPE SIZES 12" TO 72"**

VIRGINIA DEPARTMENT OF TRANSPORTATION



ROAD AND BRIDGE STANDARDS

REVISION DATE SHEET 1 OF 3

104.30

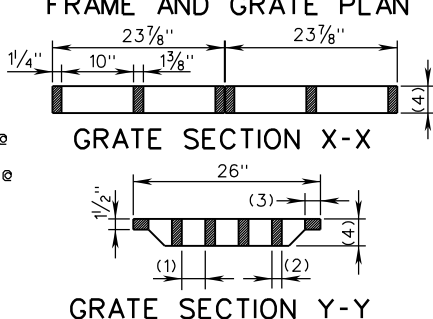
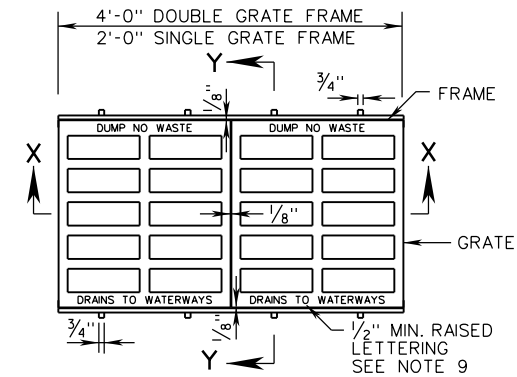
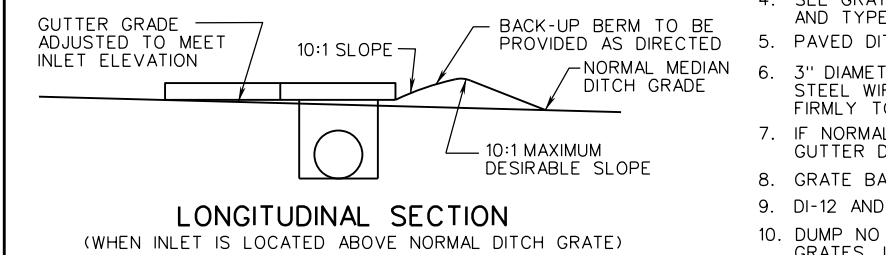
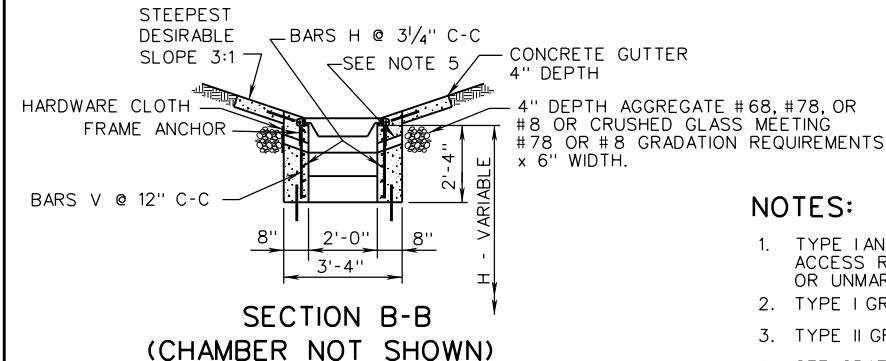
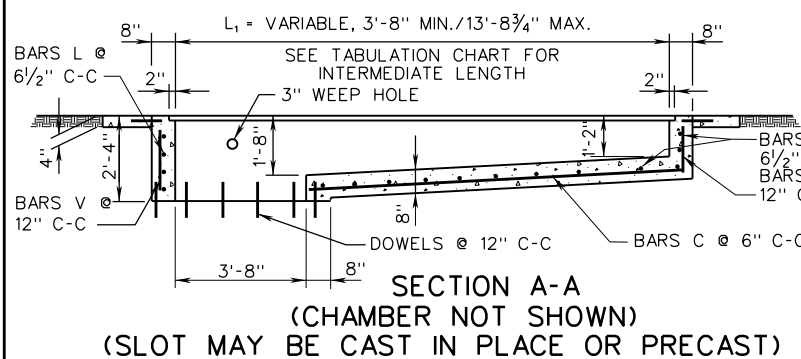
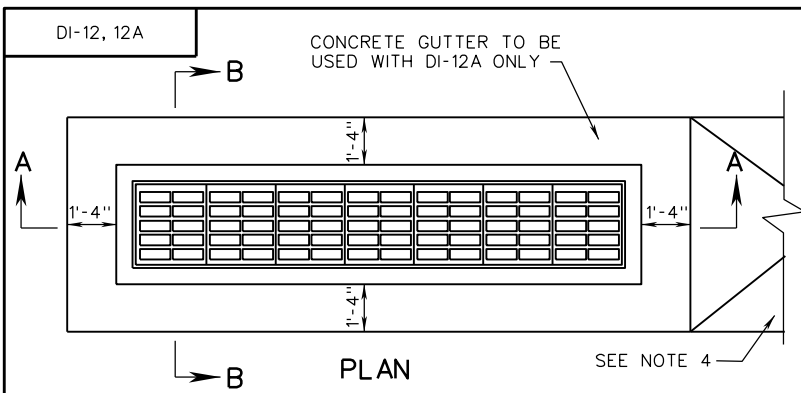

NOTE: SEE GRATE DIMENSION TABLE FOR GRATE TYPE I & II DIMENSIONS

GRATE TYPE	GRATE DIMENSIONS			
	OPENING WIDTH (1)	BAR THICKNESS (2)	END SECTION WIDTH (3)	GRATE THICKNESS (4)
TYPE I	3 1/4" 5 OPENINGS	1 3/8" 4 BARS	2 1/8"	3 3/4"
TYPE II	1 1/2" 8 OPENINGS	1 3/8" 7 BARS	2 3/16"	3 3/4"

NOTES:

- TYPE I AND TYPE II GRATES SHALL NOT BE LOCATED WITHIN THE LIMITS OF ANY PEDESTRIAN ACCESS ROUTE, SUCH AS A SIDEWALK, SHARED USE PATH, OR PEDESTRIAN CROSSING (MARKED OR UNMARKED).
- TYPE I GRATE: LIMITED ACCESS AND RURAL UNLIMITED ACCESS
- TYPE II GRATE: URBAN AREAS
- SEE GRATE DIMENSION TABLE FOR SIZE AND NUMBER OF GRATE OPENINGS REQUIRED FOR TYPE I AND TYPE II GRATE.
- PAVED DITCHES ARE TO BE TRANSITIONED TO MEET INLET GUTTER AS SHOWN IN STANDARD PG-2A.
- 3" DIAMETER WEEP HOLE WITH 12" X 12" PLASTIC HARDWARE CLOTH 1/4" MESH OR GALVANIZED STEEL WIRE, MINIMUM WIRE DIAMETER 0.03", NUMBER 4 MESH HARDWARE CLOTH ANCHORED FIRMLY TO OUTSIDE OF STRUCTURE.
- IF NORMAL DITCH GRADE IS TOO FLAT TO ALLOW FOR ADJUSTED GRADE TO INLET, A SPECIAL GUTTER DETAIL WILL BE REQUIRED ON PLANS.
- GRATE BARS TO BE PARALLEL TO DITCH FLOW.
- DI-12 AND DI-12A ARE NOT TO BE UTILIZED IN LOCATIONS NORMALLY SUBJECT TO TRAFFIC.
- DUMP NO WASTE DRAINS TO WATERWAYS LETTERING IS REQUIRED ON ALL DI-12 GRATES. LOCATION OF LETTERING MAY VARY BY MANUFACTURER.

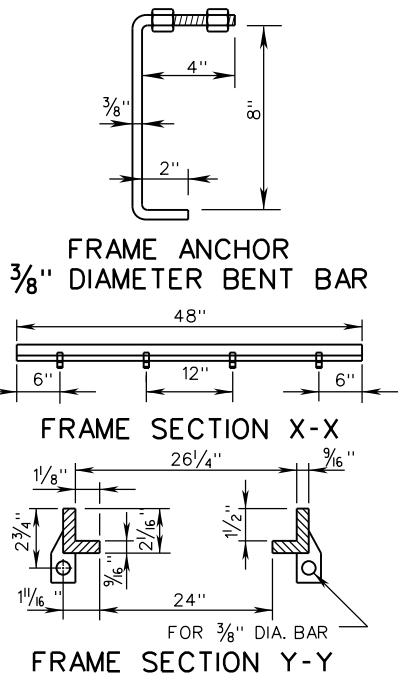

TABULATION CHARTS

APPROXIMATE QUANTITIES (SEE NOTE 2)						
CAST IN PLACE CHAMBER						
PIPE SIZES	MINIMUM DEPTH H (SEE NOTE 3)	REINFORCING STEEL LBS.	CONCRETE CU. YDS.	CHAMBER DIMENSIONS		CONCRETE CHAMBER INCREMENTS PER FOOT (SEE NOTE 1)
				W _C	L _C	CU. YDS.
12" TO 24"	4'-2"	20.5	1.20	2'-6"	3'-8"	.37
27" TO 36"	5'-6 1/4 "	30.33	2.14	3'-8"	3'-8"	.43
42" TO 54"	6'-10 1/2 "	129.80	4.39	5'-5"	5'-5"	.53
60" TO 72"	8'-6"	277.32	7.65	7'-2"	7'-2"	.69

NOTES

1. FOR EACH ADDITIONAL FOOT IN DEPTH THE INCREMENT SHOWN MUST BE MULTIPLIED BY THE ADDITIONAL DEPTH IN FEET AND ADDED TO THE CONCRETE TOTAL.
2. APPROXIMATE QUANTITIES ARE SHOWN FOR BIDDING PURPOSES ONLY: ITEMS ARE NOT TO BE BID SEPARATELY. TO OBTAIN THE TOTAL APPROXIMATE CONCRETE QUANTITIES FOR EACH INLET, THE CHAMBER, SLOT AND GUTTER (GUTTER TO BE USED WITH DI-12A ONLY) QUANTITIES MUST BE ADDED TOGETHER.
3. MINIMUM DEPTHS SHOWN ARE FOR THE SMALLEST PIPE SIZE IN EACH SERIES. MINIMUM DEPTH H = PIPE DIAMETER + PIPE WALL THICKNESS + 3'.
4. FOR APPROXIMATE QUANTITIES FOR DI-12A ADD 0.36 CU. YDS. OF CLASS A3 CONCRETE TO DI-12 QUANTITIES FOR CONCRETE GUTTER. QUANTITY SHOWN IS FOR A MINIMUM SLOT LENGTH OF 3'-8". FOR OTHER CONCRETE LENGTHS SEE CONCRETE GUTTER INCREMENTS IN THIS TABLE.
5. DI-12A CONCRETE GUTTER INCREMENT: ADD 0.07 CU. YDS. CLASS A3 CONCRETE FOR EACH ADDITIONAL FOOT OF SLOT LENGTH GREATER THAN MINIMUM 3'-8".
6. DOWELS ARE TO BE PROVIDED FOR THE JOINT BETWEEN THE CONCRETE GUTTER AND SLOT. THE COST OF DOWELS ARE TO BE INCLUDED IN THE CUBIC YARD COST FOR CONCRETE.
7. SLOT MAY BE PRECAST OR CAST IN PLACE.
8. L = LENGTH ROUNDED FOR PLAN USE.

APPROXIMATE QUANTITIES						
BRICK AND BLOCK CHAMBER						
PIPE SIZES	CHAMBER DIMENSIONS "D"	REINFORCING STEEL LBS.	CONCRETE CU. YDS.	BRICK		BLOCK
				MIN. DEPTH H	NO.	NO.
12" TO 24"	4'-0"	102.68	1.25	4'-2"	688	42
27" TO 36"	4'-0"	102.68	1.25	5'-6 1/4"	911	55
42" TO 54"	5'-6"	200.81	2.01	7'-10 1/2"	1300	111
60" TO 72"	8'-0"	404.74	3.65	9'-6"	1568	190

BRICK CHAMBER INCREMENTS PER FT.

X DIM.	DEPTH	4' DIAMETER APPROX. NO. BRICKS/FT.	5'-6" DIAMETER APPROX. NO. BRICKS/FT.	8'-0" DIAMETER APPROX. NO. BRICKS/FT.
8"	0' - 10'	165	227	330
12"	10' - 16'	250	341	495
16"	16' - 25'	330	454	660

BLOCK CHAMBER INCREMENTS PER FT.

Y DIM.	DEPTH	4' DIAMETER APPROX. NO. BRICKS/FT.	5'-6" DIAMETER APPROX. NO. BRICKS/FT.	8'-0" DIAMETER APPROX. NO. BRICKS/FT.
5"	0' - 12'	10	14	20
10"	12' - 25'	20	28	40

APPROXIMATE QUANTITIES - DI - 12 ONLY

(SEE NOTE 4)

SLOT 4' TO 14'

(SEE NOTE 8)

L (SEE NOTE 8)	L ₁	CONCRETE CU. YDS.	REINFORCING STEEL LBS.	GRATES NO.
4	3'-8"	0.81	81.27	2
6	5'-8 3/4"	1.10	122.81	3
8	7'-8"	1.30	161.90	4
10	9'-8 3/4"	1.61	203.37	5
12	11'-8"	1.91	242.45	6
14	13'-8 3/4"	2.22	283.93	7

SPECIFICATION REFERENCE

233
302

MULTIGRATE DROP INLET

FOR PIPE SIZES 12" TO 72"

VIRGINIA DEPARTMENT OF TRANSPORTATION



ROAD AND BRIDGE STANDARDS

REVISION DATE

SHEET 3 OF 3

104.32

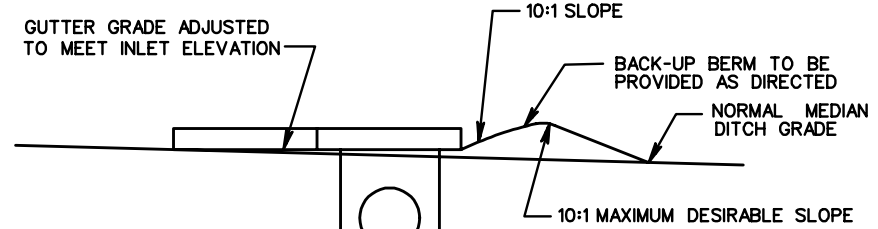
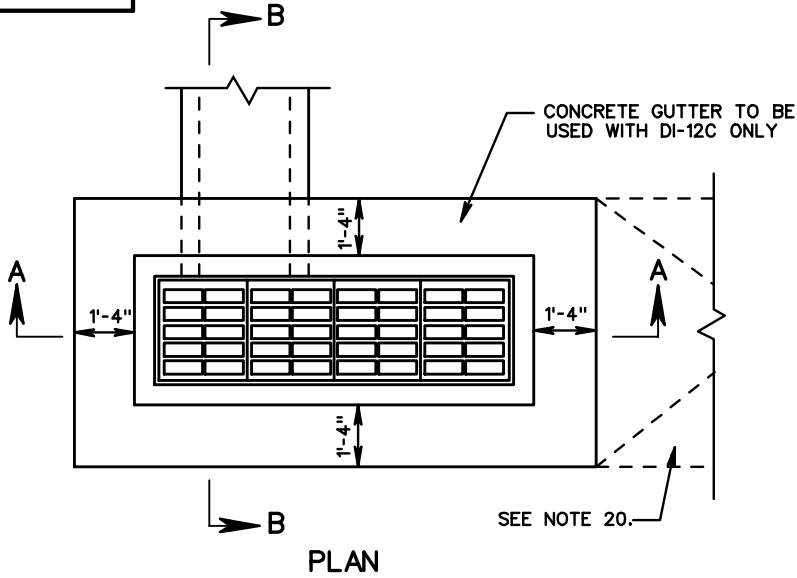

LONGITUDINAL SECTION
(WHEN INLET IS LOCATED ABOVE NORMAL DITCH GRADE)
SEE NOTE 16.

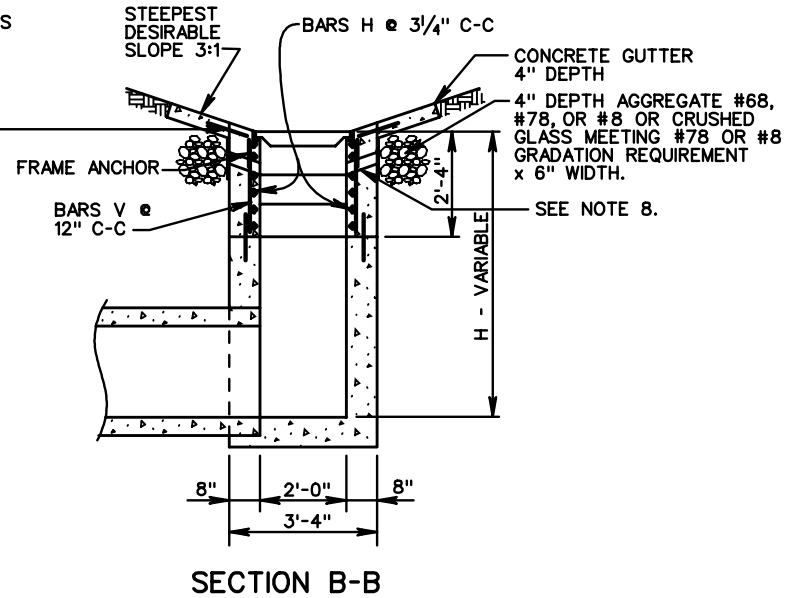
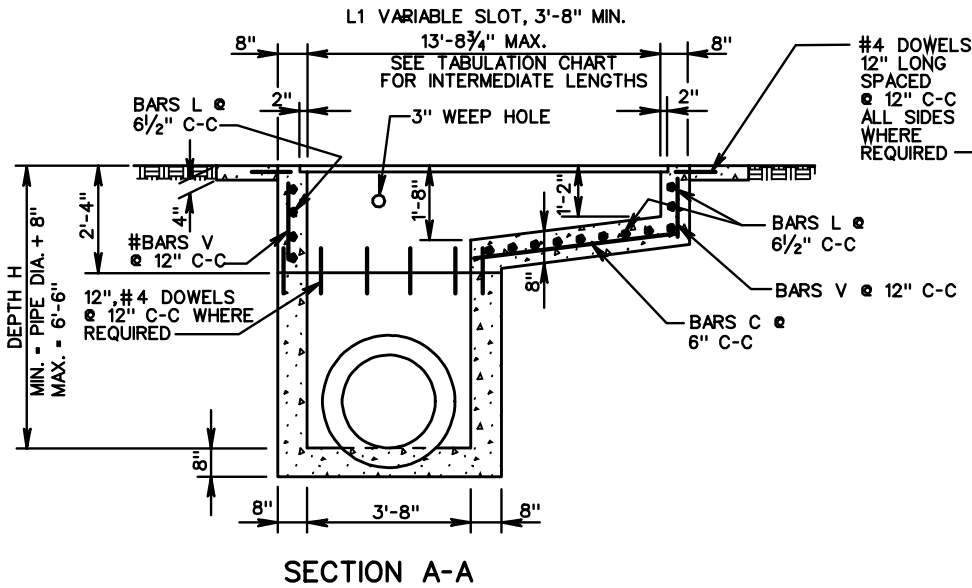

ROAD AND BRIDGE STANDARDS

SHEET 1 OF 2

REVISION DATE

104.33

MULTIGRATE DROP INLET
FOR PIPE SIZES 12" TO 36"
VIRGINIA DEPARTMENT OF TRANSPORTATION

SPECIFICATION REFERENCE

241
503

NOTES

- DEPTH OF INLET (H) TO BE SHOWN ON PLANS. FOR DEPTH GREATER THAN 6'-6", USE ST'D. DI-12, DI-12A.
- LENGTH OF SLOT (L) WILL IN EVERY CASE, BE SHOWN ON PLANS.
- ALL REINFORCING BARS TO BE #4
- DI-12C CONCRETE GUTTER INCREMENT: ADD 0.07 CU. YDS CLASS A3 CONCRETE FOR EACH ADDITIONAL FOOT OF SLOT LENGTH GREATER THAN MINIMUM 3'-8".
- GRATE BARS TO BE INSTALLED SO THEY WILL BE ALIGNED PARALLEL TO THE DITCH FLOW.
- IF NORMAL DITCH GRADE IS TOO FLAT TO ALLOW FOR ADJUSTED GRADE TO INLET A SPECIAL GUTTER DETAIL WILL BE REQUIRED ON PLANS.
- DI-12B-----NO GUTTER
DI-12C-----PERIPHERAL GUTTER
- PAVED DITCHES ARE TO BE TRANSITIONED TO MEET INLET GUTTER AS SHOWN IN STANDARD PG-2A.
- QUANTITIES SHOWN ARE FOR INLETS WITHOUT PIPES. PIPE DISPLACEMENTS MUST BE DEDUCTED TO OBTAIN TRUE QUANTITIES.
- PAVED TRANSITION WHERE REQUIRED ON PLANS. TRANSITION IS TO BE SHAPED TO CONFORM TO ROUNDED CONCRETE GUTTER OF DI-12C.
- TYPE I GRATE: LIMITED ACCESS AND RURAL UNLIMITED ACCESS
- TYPE II GRATE: URBAN AREAS
- L = LENGTH ROUNDED FOR PLAN USE.
- DI-12C: FOR APPROX. QUANTITIES FOR DI-12C, ADD 0.36 CU. YDS. OF CLASS A3 CONCRETE TO DI-12B QUANTITIES FOR CONCRETE GUTTER. QUANTITY SHOWN IS FOR A MINIMUM SLOT LENGTH OF 3'-8". FOR OTHER LENGTHS SEE CONCRETE GUTTER INCREMENT BELOW.
- DI-12B AND DI-12C ARE NOT TO BE UTILIZED IN LOCATIONS NORMALLY SUBJECT TO TRAFFIC.
- DUMP NO WASTE DRAINS TO WATERWAYS LETTERING IS REQUIRED ON ALL DI-12 GRATES. LOCATION OF LETTERING MAY VARY BY MANUFACTURER.
- TYPE I AND TYPE II GRATES SHALL NOT BE LOCATED WITHIN THE LIMITS OF ANY PEDESTRIAN ACCESS ROUTE, SUCH AS A SIDEWALK, SHARED USE PATH, OR PEDESTRIAN CROSSING (MARKED OR UNMARKED).

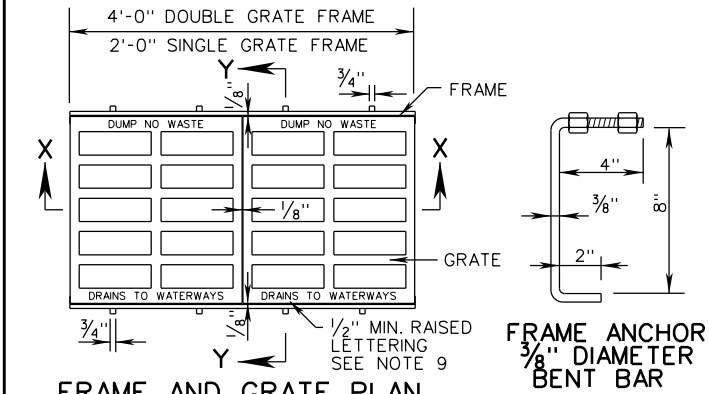

FRAME AND GRATE PLAN

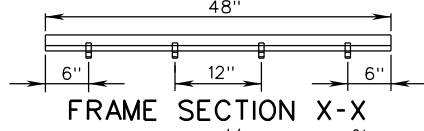

FRAME SECTION X-X

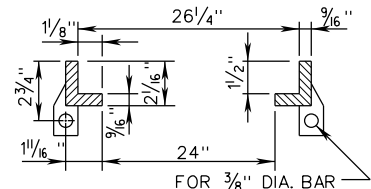

FRAME SECTION Y-Y

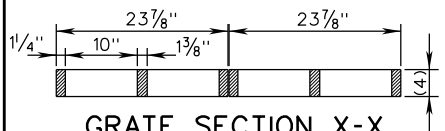

GRATE SECTION X-X

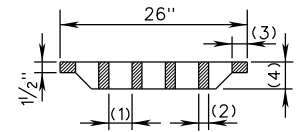

GRATE SECTION Y-Y

NOTE: SEE GRATE DIMENSION TABLE FOR GRATE TYPE I & II DIMENSIONS

GRATE DIMENSIONS				
GRATE TYPE	OPENING WIDTH (1)	BAR THICKNESS (2)	END SECTION WIDTH (3)	GRATE THICKNESS (4)
TYPE I	3 1/4"	1 3/8"	2 1/8"	3 3/4"
	5 OPENINGS	4 BARS		
TYPE II	1 1/2"	1 3/8"	2 3/16"	3 3/4"
	8 OPENINGS	7 BARS		

TABULATION CHARTS

APPROXIMATE QUANTITIES DI-12B ONLY (SEE NOTES 19 & 24)					
(MINIMUM HEIGHT) SLOT 4' TO 14' (SEE NOTE 23)					
L (SEE NOTE 23)	L1	CONCRETE CU. YDS.	REINFORCING STEEL LBS.	NUMBER GRATES	CONCRETE CHAMBER INCREMENTS PER FOOT CU. YDS.
4	3'-8"	0.99	81.27	2	.35
6	5'-8 3/4"	1.28	122.81	3	
8	7'-8"	1.48	161.90	4	
10	9'-8 3/4"	1.79	203.37	5	
12	11'-8"	2.09	242.45	6	
14	13'-8 3/4"	2.40	283.93	7	

SPECIFICATION REFERENCE
241 503

MULTIGRATE DROP INLET
FOR PIPE SIZES 12" TO 36"
VIRGINIA DEPARTMENT OF TRANSPORTATION

VDOT ROAD AND BRIDGE STANDARDS	
REVISION DATE 08/14	SHEET 2 OF 2 104.34

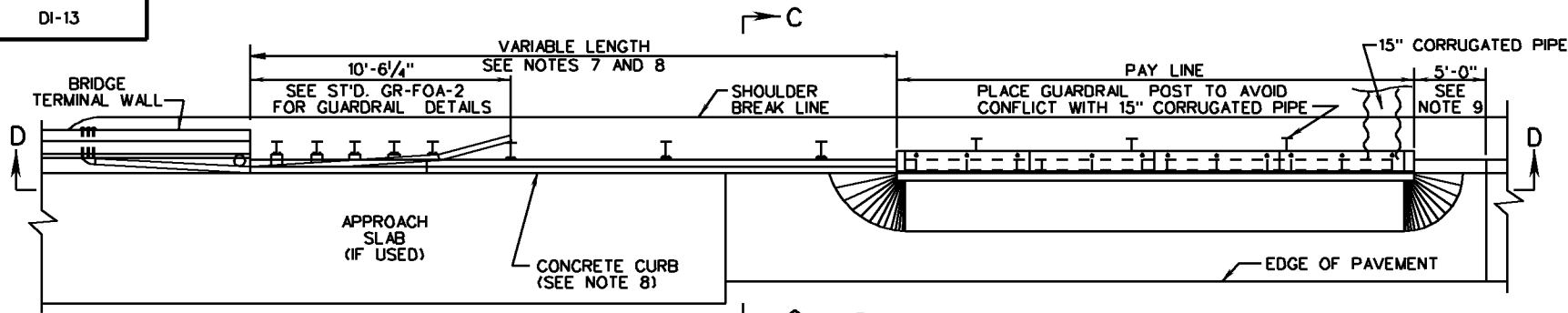

PLAN
(BRIDGE RUN ON & RUN OFF LOCATION)

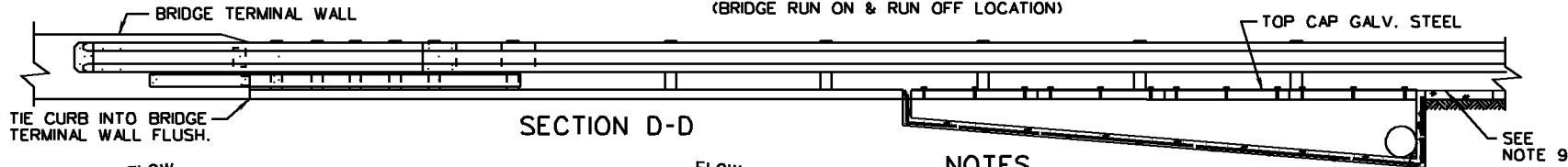

SECTION D-D

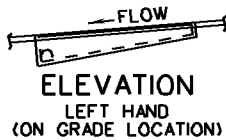

ELEVATION
LEFT HAND
(ON GRADE LOCATION)

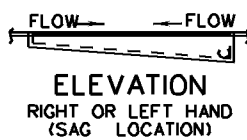

ELEVATION
RIGHT OR LEFT HAND
(SAG LOCATION)

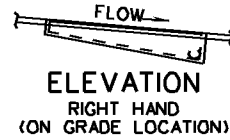

ELEVATION
RIGHT HAND
(ON GRADE LOCATION)

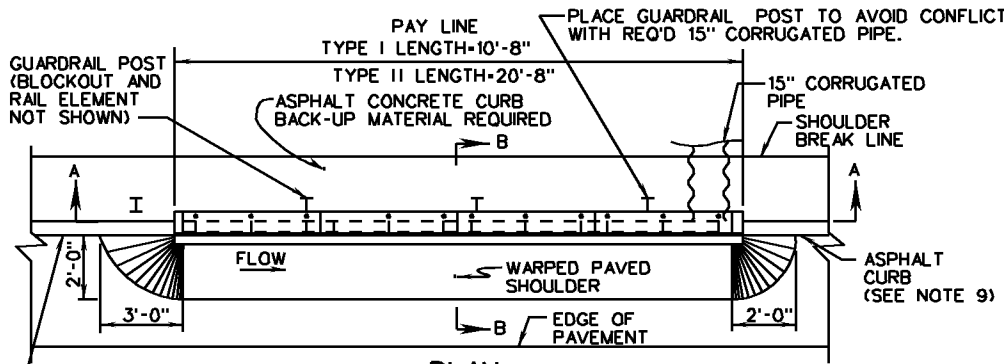

PLAN
(ROADWAY LOCATION)

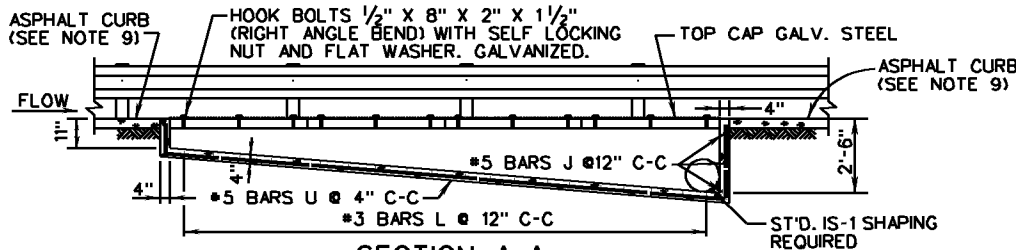

SECTION A-A

NOTES

1. THIS UNIT MAY BE PRECAST OR CAST IN PLACE. CAST IN PLACE CONCRETE IS TO BE CLASS A3 (3000 PSI). PRECAST CONCRETE IS TO BE 4000 PSI.
2. ALL REINFORCING STEEL IS TO BE GRADE 60.
3. PIPES ARE TO BE PLACED ON THE DOWN GRADE OR LOWER END OF INLET.
4. PRECAST UNITS MUST BE FURNISHED WITH PIPES PLACED TO THE RIGHT OR LEFT ACCORDING TO THE FLOW DOWN GRADE, WHEN FACING THE INLET FROM THE CENTER OF THE ROAD.
5. WHEN THIS INLET IS USED IN A SAG LOCATION EITHER A RIGHT HAND OR A LEFT HAND UNIT MAY BE USED.
6. BACKFILL TO BE PLACED AND COMPACTED IN ACCORDANCE WITH SECTION 303.09 OF THE ROAD AND BRIDGE SPECIFICATIONS.
7. DI-13 STRUCTURE SHALL BE LOCATED A MINIMUM OF 11 FEET FROM THE END OF THE BRIDGE TERMINAL WALL. IN LOCATIONS THAT INCLUDE AN APPROACH SLAB EXTENDING BEYOND THE END OF THE BRIDGE TERMINAL WALL, THE DI13 STRUCTURE SHALL BE PLACED A MINIMUM OF 5 FEET BEYOND THE END OF THE APPROACH SLAB.
8. STANDARD CG-3 CONCRETE CURB SHALL BE PLACED FROM THE END OF THE INLET TO THE BEGINNING OF THE BRIDGE TERMINAL WALL. ASPHALT CONCRETE CURB BACK UP MATERIAL SHALL BE PLACED BEHIND CG-3 AS SHOWN IN SECTION C-C. THE COST OF CG-3 CURB AND ASPHALT CONCRETE CURB BACK UP MATERIAL SHALL BE PAID FOR SEPERATELY FROM THE DI-13 STRUCTURE.
9. STANDARD MC-3B ASPHALT CURB SHALL BE EXTENDED 5 FEET PAST THE END OF THE INLET AND TRANSITION DOWN TO GRADE LEVEL. LONGER LENGTHS OF CURB MAY BE NEEDED BEYOND THIS LIMIT AND THEN TRANSITIONED DOWN IN 5 FEET. SEE THE ROADWAY PLANS FOR THE REQUIRED LENGTH OF CURB. THE COST OF MC-3B CURB AND ASPHALT CONCRETE CURB BACKUP MATERIAL SHALL BE PAID FOR SEPERATELY FROM THE DI-13 STRUCTURE.
10. FOR DETAILS OF SLOT INLET AND PIPE INSTALLATION, SEE SECTION B-B ON SHEET 2 OF 2.



ROAD AND BRIDGE STANDARDS

SHOULDER SLOT INLET

SPECIFICATION
REFERENCE

SHEET 1 OF 2

REVISION DATE

VIRGINIA DEPARTMENT OF TRANSPORTATION

233
302

104.35

10/09

NOTES

1. SEE SHEET 1 OF 2 (104.35) OF ROAD AND BRIDGE STANDARDS FOR ADDITIONAL DESIGN AND PLACING INFORMATION.
2. TOP CAP IS TO BE FABRICATED FROM A-36 STEEL PLATE 1/4" THICK. ALL JOINTS ARE TO BE WELDED USING 1/4" FILLET WELDS AND THE COMPLETE UNIT IS TO BE GALVANIZED.
3. GUARDRAIL MUST BE FLUSH WITH THE FACE OF CURB.

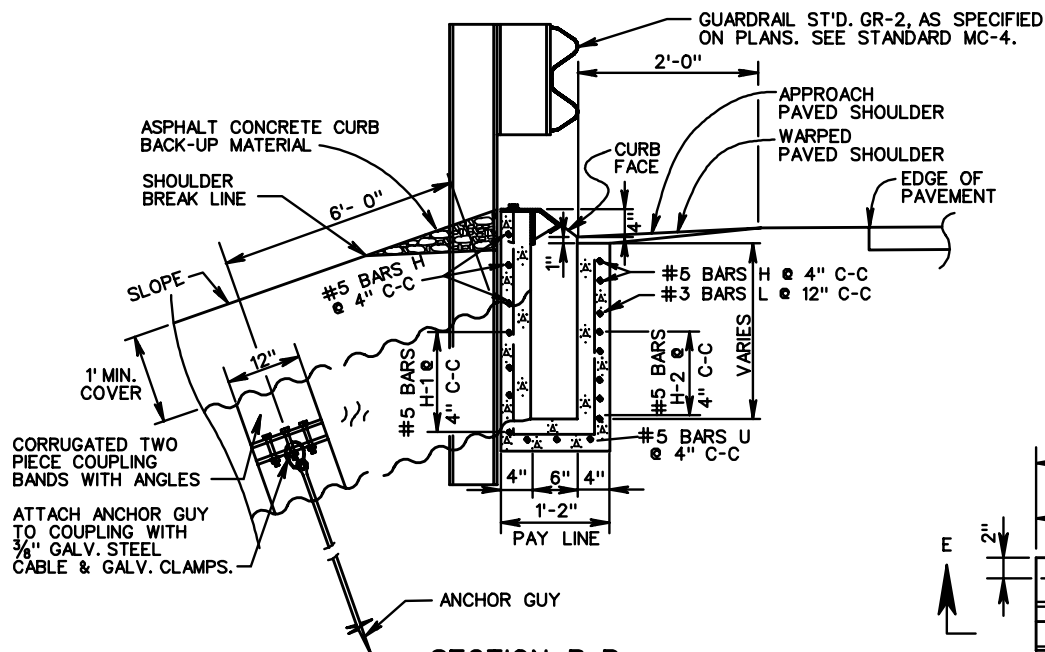

SECTION B-B

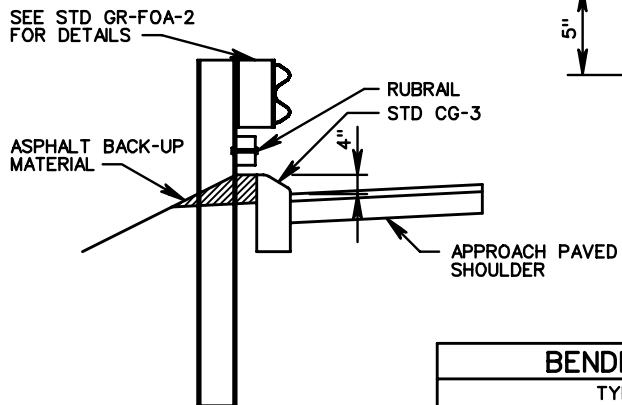

SECTION C-C

TYPE I		TYPE II	
MARK	X	MARK	X
U	10'-5 1/2"	U	20'-4 3/4"

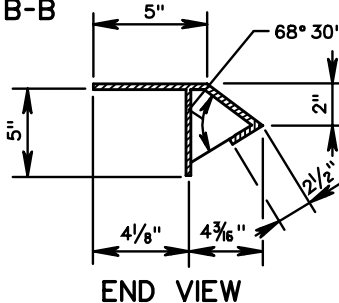

END VIEW

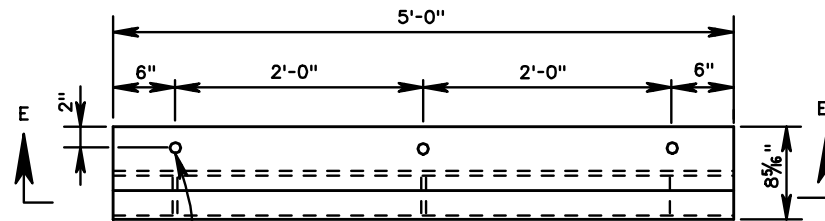

PLAN

TOP CAP WEIGHT 56 LBS.
PER EACH 5'-0" SECTION

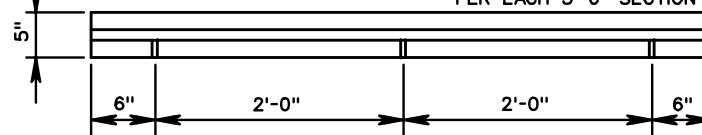

**SECTION E-E
TOP CAP DETAIL**

**TYPICAL METHOD OF INSTALLATION
FOR PIPE ON FILL SLOPE**

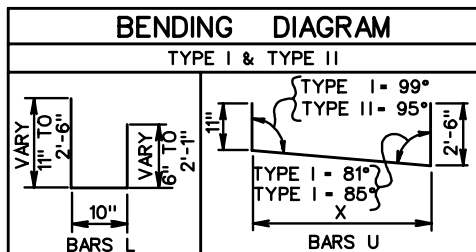

BENDING DIAGRAM

TYPE I & TYPE II

REINFORCING STEEL SCHEDULE									
TYPE I					TYPE II				
MARK	SIZE	NO.	SPA.	LENGTH	MARK	SIZE	NO.	SPA.	LENGTH
H	#5	6	4"	10'-4"	H	#5	6	4"	20'-4"
H-1	#5	4	4"	8'-11" TO 2'-8"	H-1	#5	4	4"	12'-8" TO 2'-8"
H-2	#5	4	4"	8'-11" TO 2'-8"	H-2	#5	4	4"	12'-8" TO 2'-8"
J	#5	5	12"	0'-10"	J	#5	5	12"	0'-10"
L	#5	11	12"	5'-5" TO 2'-3"	L	#5	21	12"	5'-5" TO 2'-3"
U	#5	3	4"	13'-10"	U	#5	3	4"	23'-10"

SPECIFICATION REFERENCE

233
302

SHOULDER SLOT INLET

VIRGINIA DEPARTMENT OF TRANSPORTATION



ROAD AND BRIDGE STANDARDS

REVISION DATE

SHEET 2 OF 2

104.36

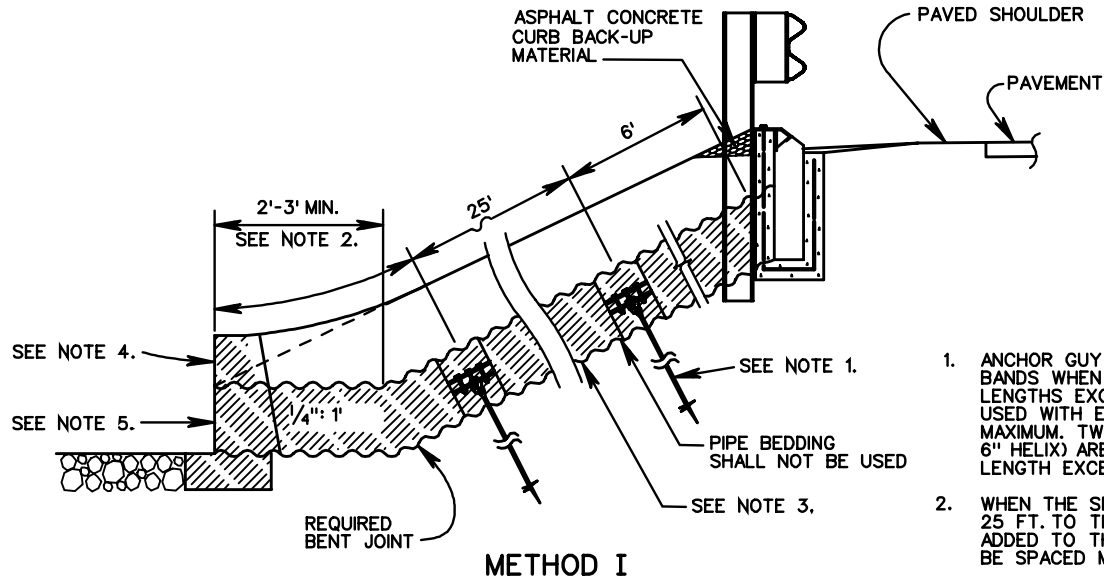

METHOD I

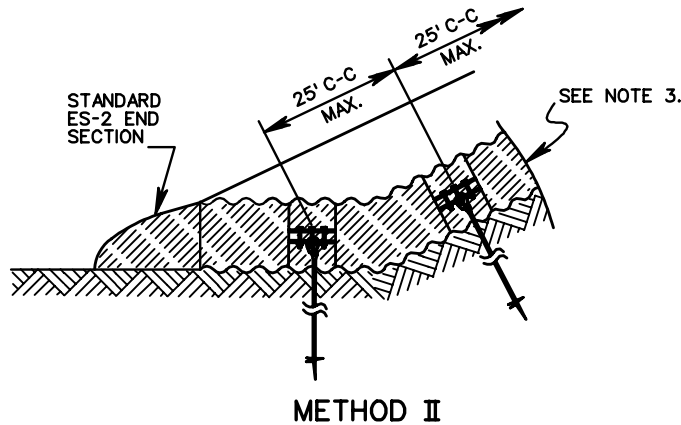

METHOD II

NOTES

1. ANCHOR GUY SCREWS ARE NOT TO BE USED WITH THE COUPLING BANDS WHEN THE PIPE LENGTHS ARE LESS THAN 50 FT. WHEN PIPE LENGTHS EXCEED 50 FT. TWO (2) ANCHOR GUY SCREWS ARE TO BE USED WITH EACH COUPLING BAND SPACED AT 25 FT. C-C MAXIMUM. TWO (2) ANCHOR GUY SCREWS, (1/2" DIAMETER X 5'-6", 6" HELIX) ARE TO BE USED WITH EACH COUPLING BAND, WHEN PIPE LENGTH EXCEEDS 50 FT.
2. WHEN THE SPACING OF THE LOWER COUPLING FALLS CLOSER THAN 25 FT. TO THE STORM SYSTEM STRUCTURE THE DISTANCE IS TO BE ADDED TO THE LAST FULL 12'-6" SPACE AND THE COUPLING IS TO BE SPACED MID-WAY OF THE TOTAL DISTANCE.
3. REQUIRED 15" CORRUGATED PIPE. SEE PLAN FOR LIN. FT. QUANTITIES. THE LIN. FT. COST FOR THE PIPE IS TO INCLUDE FURNISHING AND PLACING COUPLINGS AND ANCHOR GUYS. CORRUGATED POLY-ETHYLENE PIPE LENGTHS GREATER THAN 50 FT. MAY BE USED AS AN ALTERNATE PROVIDED THE COUPLING BAND ANCHORAGE DESIGN IS SUBMITTED BY THE MANUFACTURER FOR THE ENGINEER'S REVIEW AND APPROVAL.
4. REQUIRED 15" CORRUGATED PIPE MUST BE TERMINATED AT THE TOE OF FILL SLOPE WITH AN APPROPRIATE END TREATMENT. FOR 3:1 SLOPES AND FLATTER THE PIPE MAY BE TERMINATED WITH A STANDARD ES-2 END SECTION OR TIED INTO ANOTHER DRAINAGE STRUCTURE. FOR SLOPES 3:1 AND STEEPER (MAX. 1/2:1) THE 15" PIPE MUST HAVE ONE OF THE FOLLOWING END TREATMENTS (SEE PLANS FOR REQUIRED TYPE OF STRUCTURE):
 - METHOD I: TERMINATE PIPE WITH A STANDARD END WALL OR OTHER DRAINAGE STRUCTURE, TO BE APPROVED BY THE ENGINEER. FOR PIPE LENGTHS LONGER THAN 50 FT., COUPLING BANDS WITH ANCHOR GUYS ARE TO BE USED AT 12'-6" C-C MAXIMUM SPACING.
 - METHOD II: TERMINATE PIPE WITH A STANDARD ES-2 END SECTION ANCHORED WITH COUPLING BAND AND ANCHOR GUYS. ADDITIONAL COUPLING BANDS AND ANCHOR GUYS ARE TO BE PLACED AT 12'-6" C-C MAXIMUM FOR THE REMAINING LENGTH OF PIPE.
5. MORTAR REQUIRED CORRUGATED PIPE INTO THE WALL IF PRECAST STRUCTURE IS USED.



ROAD AND BRIDGE STANDARDS

METHOD OF OUTLET PIPE INSTALLATION FOR DI-13

SPECIFICATION REFERENCE

SHEET 1 OF 1

REVISION DATE

VIRGINIA DEPARTMENT OF TRANSPORTATION

104.37

232
302

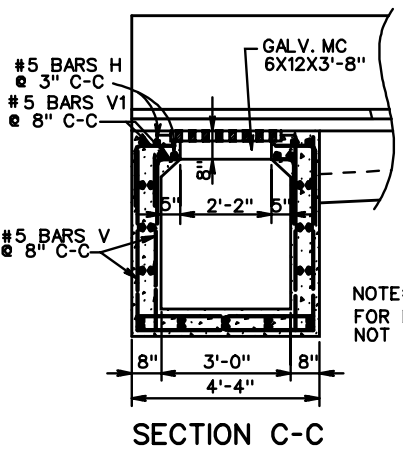
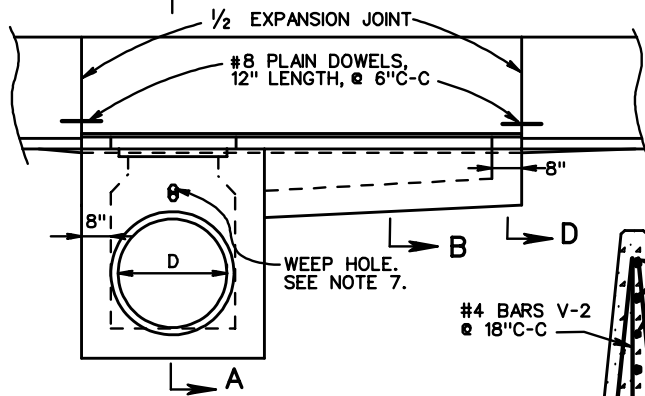
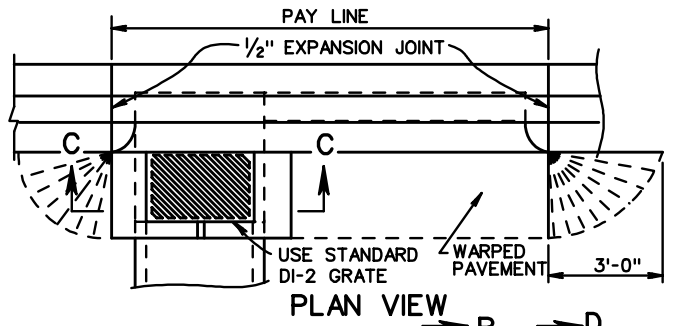

NOTE:
FOR DIMENSIONS, QUANTITIES AND NOTES NOT SHOWN SEE SHEET 2 OF 2.

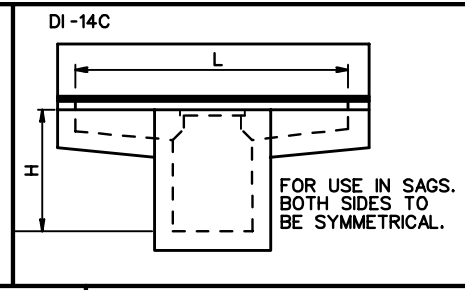
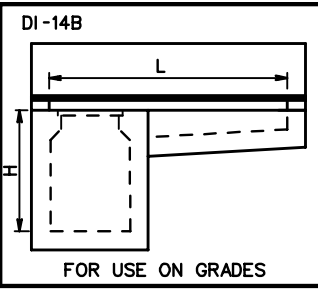
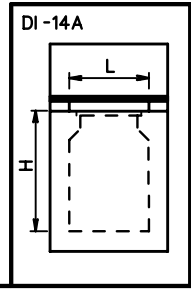
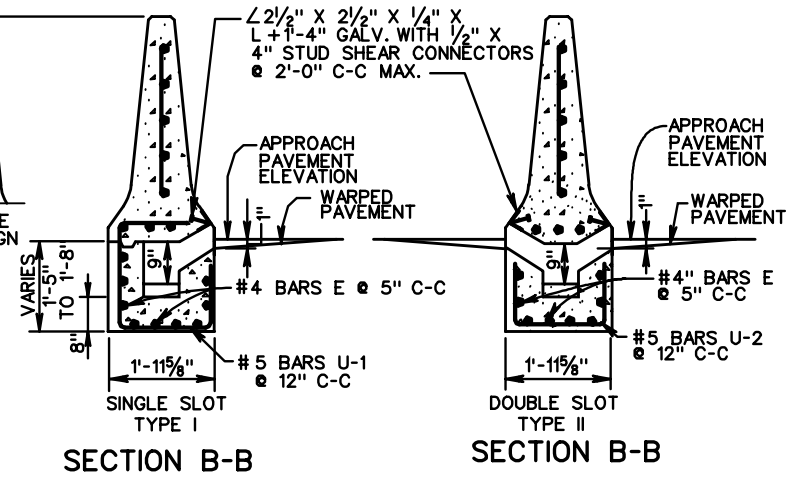
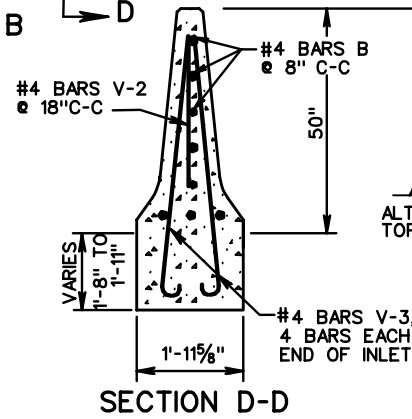
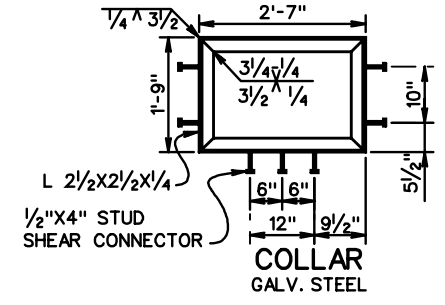
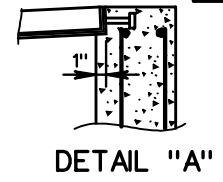
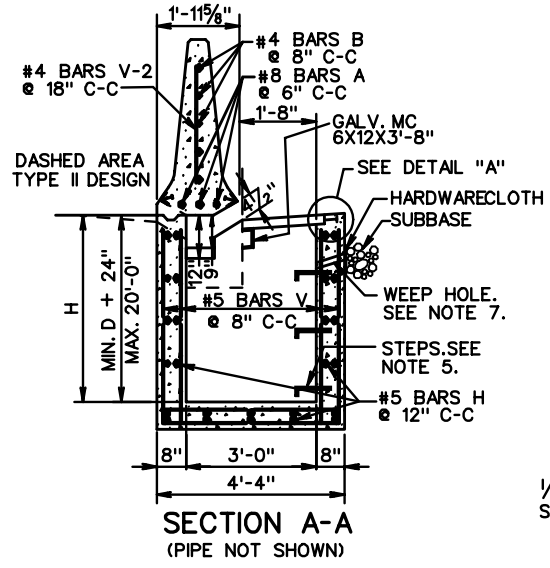

FOR USE ON GRADES

SPECIFICATION REFERENCE
233
302

CONCRETE MEDIAN BARRIER DROP INLET
12"-36" PIPE: DEPTH (H)-20'-0" MAX.
VIRGINIA DEPARTMENT OF TRANSPORTATION

VDOT	
ROAD AND BRIDGE STANDARDS	
REVISION DATE	SHEET 1 OF 2
104.38	

TABLE OF QUANTITIES

TYPE	L	CONCRETE				REINFORCING STEEL																						
		TYPE I		TYPE II		BARS A		BARS B		BARS E		BARS H		BARS U-1		BARS U-2		BARS V		BARS V-1		BARS V-2		BARS V-3		TYPE I	TYPE II	
		FT.	CU. YD.	CU. YD.	NO.	LN.*FT.	NO.	LN.*FT.	NO.	LN.*FT.	NO.	LN.*FT.	NO.	LN.*FT.	NO.	LN.*FT.	NO.	LN.*FT.	NO.	LN.*FT.	NO.	LN.*FT.	NO.	LN.*FT.	NO.	LN.*FT.	Lbs.	Lbs.
DI-14A	3'	2.23	2.20	3	4'-0"	5	4'-0"	-	-	38	4'-0"	-	-	-	-	48	3'-4"	12	2'-6"	3	3'-8"	8	5'-9"	455	455			
	4'	2.45	2.44	3	5'-0"	5	5'-0"	8	1'-4"	38	4'-0"	2	5'-2" TO 5'-8"	2	3'-1" TO 3'-7"	48	3'-4"	12	2'-6"	4	3'-8"	8	5'-9"	485	480			
DI-14B	6'	2.91	2.89	3	7'-0"	5	7'-0"	8	3'-4"	38	4'-0"	4	5'-2" TO 5'-8"	4	3'-1" TO 3'-7"	48	3'-4"	12	2'-6"	5	3'-8"	8	5'-9"	528	519			
	8'	3.36	3.34	3	9'-0"	5	9'-0"	8	5'-4"	38	4'-0"	6	5'-2" TO 5'-8"	6	3'-1" TO 3'-7"	48	3'-4"	12	2'-6"	7	3'-8"	8	5'-9"	573	560			
	10'	3.82	3.78	3	11'-0"	5	11'-0"	8	7'-4"	38	4'-0"	8	5'-2" TO 5'-8"	8	3'-1" TO 3'-7"	48	3'-4"	12	2'-6"	8	3'-8"	8	5'-9"	617	600			
	12'	4.28	4.24	3	13'-0"	5	13'-0"	8	9'-4"	38	4'-0"	10	5'-2" TO 5'-8"	10	3'-1" TO 3'-7"	48	3'-4"	12	2'-6"	9	3'-8"	8	5'-9"	660	639			
	14'	4.74	4.69	3	15'-0"	5	15'-0"	8	11'-4"	38	4'-0"	12	5'-2" TO 5'-8"	12	3'-1" TO 3'-7"	48	3'-4"	12	2'-6"	11	3'-8"	8	5'-9"	706	679			
	16'	5.20	5.14	3	17'-0"	5	17'-0"	8	13'-4"	38	4'-0"	14	5'-2" TO 5'-8"	14	3'-1" TO 3'-7"	48	3'-4"	12	2'-6"	12	3'-8"	8	5'-9"	749	719			
	18'	5.67	5.61	3	19'-0"	5	19'-0"	8	15'-4"	38	4'-0"	16	5'-2" TO 5'-8"	16	3'-1" TO 3'-7"	48	3'-4"	12	2'-6"	13	3'-8"	8	5'-9"	793	758			
	20'	6.13	6.06	3	21'-0"	5	21'-0"	8	17'-4"	38	4'-0"	18	5'-2" TO 5'-8"	18	3'-1" TO 3'-7"	48	3'-4"	12	2'-6"	15	3'-8"	8	5'-9"	838	799			
	DI-14C	6'	2.91	2.89	3	7'-0"	5	7'-0"	16	2'-0"	38	4'-0"	6	5'-2" TO 5'-8"	6	3'-1" TO 3'-7"	48	3'-4"	12	2'-6"	5	3'-8"	8	5'-9"	543	530		
		8'	3.36	3.34	3	9'-0"	5	9'-0"	16	3'-0"	38	4'-0"	8	5'-2" TO 5'-8"	8	3'-1" TO 3'-7"	48	3'-4"	12	2'-6"	7	3'-8"	8	5'-9"	588	571		
10'		3.82	3.79	3	11'-0"	5	11'-0"	16	4'-0"	38	4'-0"	10	5'-2" TO 5'-8"	10	3'-1" TO 3'-7"	48	3'-4"	12	2'-6"	8	3'-8"	8	5'-9"	632	610			
12'		4.28	4.24	3	13'-0"	5	13'-0"	16	5'-0"	38	4'-0"	12	5'-2" TO 5'-8"	12	3'-1" TO 3'-7"	48	3'-4"	12	2'-6"	9	3'-8"	8	5'-9"	675	646			
14'		4.74	4.69	3	15'-0"	5	15'-0"	16	6'-0"	38	4'-0"	14	5'-2" TO 5'-8"	14	3'-1" TO 3'-7"	48	3'-4"	12	2'-6"	11	3'-8"	8	5'-9"	720	690			
16'		5.20	5.14	3	17'-0"	5	17'-0"	16	7'-0"	38	4'-0"	16	5'-2" TO 5'-8"	16	3'-1" TO 3'-7"	48	3'-4"	12	2'-6"	12	3'-8"	8	5'-9"	764	729			
18'		5.67	5.61	3	19'-0"	5	19'-0"	16	8'-0"	38	4'-0"	18	5'-2" TO 5'-8"	18	3'-1" TO 3'-7"	48	3'-4"	12	2'-6"	13	3'-8"	8	5'-9"	807	768			
20'		6.13	6.06	3	21'-0"	5	21'-0"	16	9'-0"	38	4'-0"	20	5'-2" TO 5'-8"	20	3'-1" TO 3'-7"	48	3'-4"	12	2'-6"	15	3'-8"	8	5'-9"	853	809			

NOTES

- DEPTH OF INLET (H) TO BE SHOWN ON PLANS.
- THE "H" DIMENSION SHOWN ON THE STANDARDS AND SPECIFIED ON THE PLANS WILL BE MEASURED FROM THE INVERT OF THE OUTFALL PIPE TO THE TOP OF THE STRUCTURE. PLAN "H" DIMENSIONS ARE APPROXIMATE ONLY FOR ESTIMATING PURPOSES AND THE ACTUAL DIMENSIONS SHALL BE DETERMINED BY THE CONTRACTOR FROM FIELD CONDITIONS.
- WHEN SPECIFIED ON THE PLANS THE INVERT IS TO BE SHAPED IN ACCORDANCE WITH STANDARD IS-1. THE COST OF FURNISHING AND PLACING ALL MATERIALS INCIDENTAL TO THE SHAPING IS TO BE INCLUDED IN THE BID PRICE FOR THE STRUCTURE.
- IN THE EVENT THE INVERT OF THE OUTFALL PIPE IS HIGHER THAN THE BOTTOM OF THE STRUCTURE, THE INVERT OF THE STRUCTURE SHALL BE SHAPED WITH CEMENT MORTAR TO PREVENT STANDING OR PONDING OF WATER IN THE STRUCTURE. THE COST OF FURNISHING AND PLACING ALL MATERIALS INCIDENTAL TO THE SHAPING IS TO BE INCLUDED IN THE BID PRICE FOR THE STRUCTURE.
- STEPS ARE TO BE PROVIDED WHEN H IS 4'-0" OR GREATER. FOR DETAILS SEE STANDARD ST-1.
- THIS ITEM MAY BE PRECAST OR CAST-IN-PLACE.
- 3" DIAMETER WEEP HOLE TO BE LOCATED TO DRAIN SUBBASE MATERIAL. WEEP HOLE WITH 12"X12" PLASTIC HARDWARE CLOTH 1/4" MESH OR GALVANIZED STEEL WIRE, MINIMUM WIRE DIAMETER 0.03", NUMBER 4 MESH HARDWARE CLOTH ANCHORED FIRMLY TO THE OUTSIDE OF THE STRUCTURE.
- ALL REINFORCING STEEL SHALL HAVE A MIN. COVER OF 2".
- ALL REINFORCING STEEL TO BE CUT CLEAR OF ALL OPENINGS BY 2".
- CAST-IN PLACE CONCRETE IS TO BE CLASS A3 (3000 PSI). PRECAST CONCRETE IS TO BE 4000 PSI.
- LENGTH OF SLOT (L) WILL, IN EVERY CASE, BE SHOWN ON PLANS.
- CONCRETE QUANTITIES SHOWN ARE FOR DEPTH (H) OF 3'-0" WITHOUT PIPES. THE AMOUNT DISPLACED BY PIPES MUST BE DEDUCTED TO OBTAIN TRUE QUANTITIES. FOR INLETS OF DIFFERENT DEPTHS ADD OR SUBTRACT 0.36 CUBIC YARDS OF CONCRETE FOR EACH FOOT OF DEPTH. AND 84 LBS. OF REINFORCING STEEL.
- LENGTH OF ANGLE IRON AS SHOWN ON SHEET 1 OF 2 IS TO BE L + 16" AT 4.10 LBS./FT..
- * DENOTES LENGTH OF ONE (1) BAR.
- GRATE TO BE INSTALLED SO SLOTS WILL DIRECT WATER TOWARD THE INLET THROAT. GRATE MUST BE REVERSIBLE (RIGHT HAND GRATE IS SHOWN).
- PROVIDE SAFETY SLABS WHEN SPECIFIED ON THE PLANS.
- FOR DETAILS AND DIMENSIONS NOT SHOWN FOR MEDIAN BARRIER SEE STANDARD MB-12.
- QUANTITIES INCLUDE MB-12.



ROAD AND BRIDGE STANDARDS

SHEET 2 OF 2

REVISION DATE

104.39

CONCRETE MEDIAN BARRIER DROP INLET

12"-36" PIPE: DEPTH (H) = 20'-0" MAX.

VIRGINIA DEPARTMENT OF TRANSPORTATION

SPECIFICATION REFERENCE

233
302

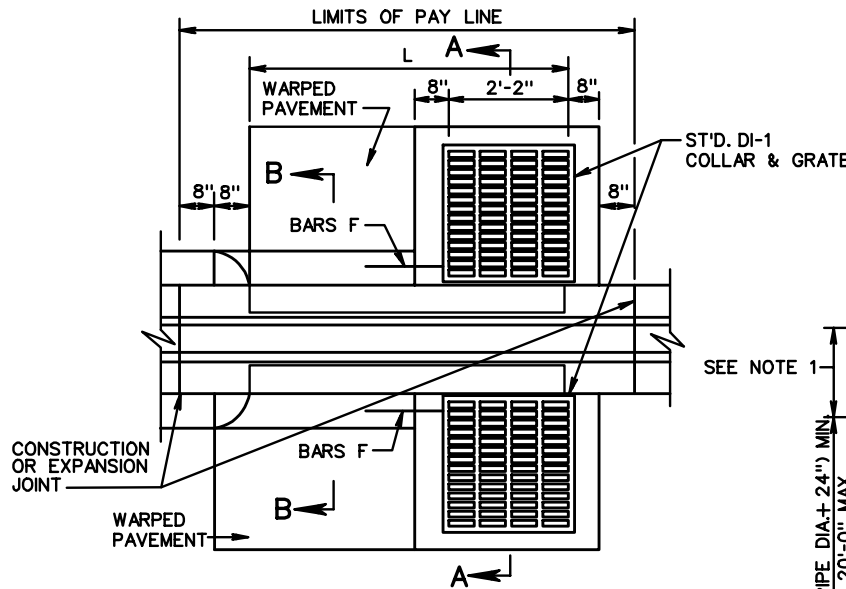

PLAN VIEW

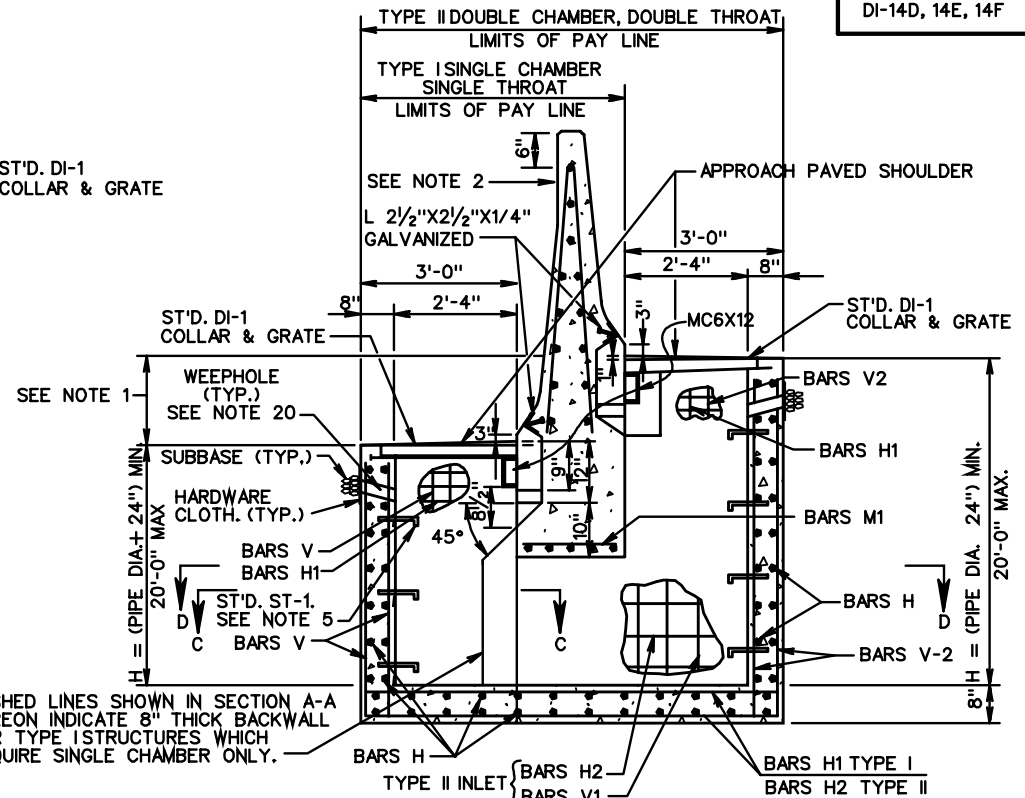

SECTION A-A

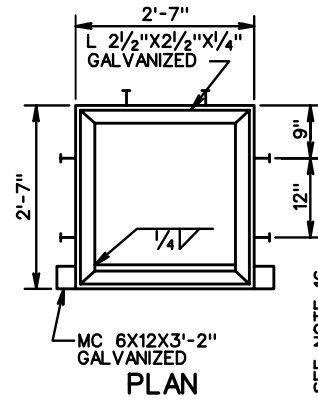

PLAN

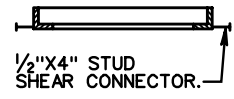

SECTION COLLAR DETAIL

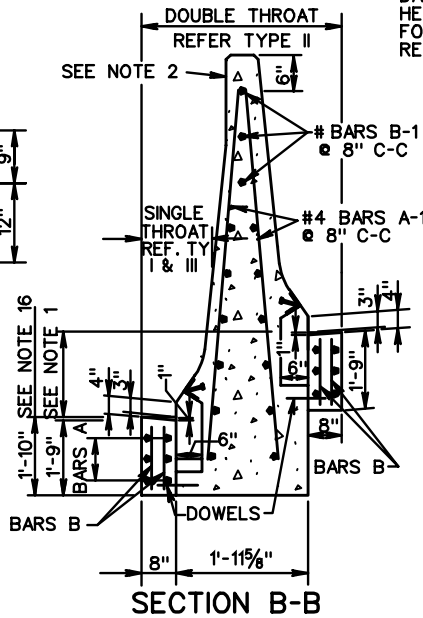

SECTION B-B

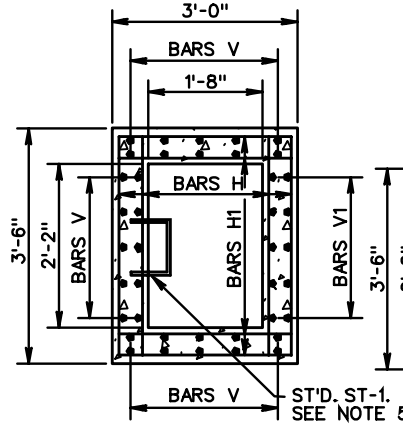

SECTION C-C TYPE I & III

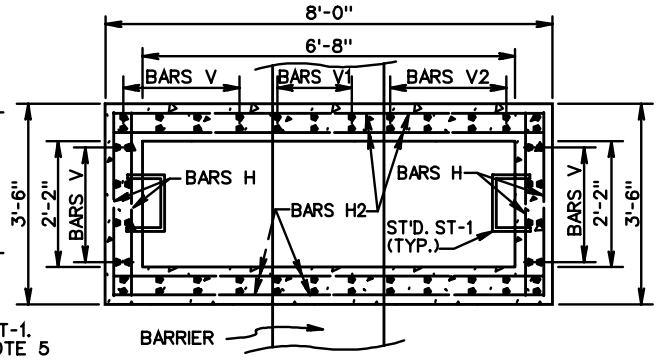

SECTION D-D TYPE II (NOT TO SCALE)

SEE NOTES ON SHEET 2 OF 2.

SPECIFICATION REFERENCE
233 302

CONCRETE MEDIAN BARRIER DROP INLET

12"-24" PIPE: DEPTH (H) - 20' MAX.
VIRGINIA DEPARTMENT OF TRANSPORTATION

VDOT	
ROAD AND BRIDGE STANDARDS	
REVISION DATE	SHEET 1 OF 2
104.40	

NOTES

- VARIES GREATER THAN: 0' TO 18" MAX. TYPE I CHAMBER 4" TO 3' MAX. TYPE I CHAMBER.
- FOR DETAILS AND DIMENSIONS NOT SHOWN FOR MEDIAN BARRIER, SEE STANDARD MB-13.
- GALVANIZED MC-6 X 12 IS TO BE WELDED UNDER THE COLLAR AND EXTENDED INTO SIDEWALLS TO WITHIN 2" OF OUTSIDE FACE.
- ALL REINFORCING BARS ARE TO BE GRADE 60 STEEL WITH MIN. OF 1/2" CONCRETE COVER. ANY BARS IN CONFLICT WITH PIPE SHELL AND/OR TOP SLAB OPENING ARE TO BE FIELD CUT TO PROVIDE THE REQUIRED COVER.
- DO NOT LOCATE STANDARD ST-1 STEPS ON CHAMBER WALLS THAT HAVE PIPES WHEN POSSIBLE.
- 8 DOWELS REQUIRED FOR DI-14F, MIN. L = 7'-0". ADD 2 DOWELS FOR EACH ADDITIONAL FOOT. 4 DOWELS REQUIRED FOR DI-14E, MIN. L = 4'-0". ADD 2 DOWELS FOR EACH ADDITIONAL FOOT.
- 12 BARS A REQUIRED FOR DI-14F.
- LENGTH OF BARS A, DI-14F = $\frac{L - (2' - 6")}{2}$
- DO NOT USE WITH DI-14D.
- USE 6 BARS F FOR DI-14F TYPE I.
- DO NOT USE WITH TYPE III
- ADD 4 ADDITIONAL BARS FOR EACH EXTRA FOOT OF DEPTH.
- USE 12 BARS F FOR DI-14F TYPE II
- 24 BARS A ARE REQUIRED FOR DI-14F.
- A MINIMUM 22" FOOTING DEPTH IS REQUIRED FOR FORMING THE INLET SLOT. SEE PLANS FOR LENGTH "L".
- REFER TO PLANS FOR STRUCTURE LOCATIONS, DATA AND DIMENSIONS.
- REFER TO PLANS FOR LOCATIONS OF PIPES AND INVERTS.
- FOR TYPE III, COST OF ACCOMMODATION OF INLET THROAT IS TO BE INCLUDED IN COST OF WALL BARRIER.
- FOR TYPE III, SEE WALL PLANS FOR WALL FOOTING DETAILS.
- 3" DIAMETER WEEP HOLE WITH 12"X12" PLASTIC HARDWARE CLOTH, 1/4" MESH OR GALV. STEEL WIRE, MIN. WIRE DIA. 0.03", NO. 4 MESH HARDWARE CLOTH ANCHORED FIRMLY TO THE OUTSIDE OF THE STRUCTURE.
- TYPE I DENOTES INLET WITH SINGLE THROAT AND CHAMBER. TYPE II DENOTES INLET WITH DOUBLE THROAT AND CHAMBER. TYPE III DENOTES INLET WITH SINGLE THROAT AND CHAMBER ADJACENT TO WALL OR BARRIER.
- MAXIMUM PIPE SIZE IS 24" DIAMETER.
- CONCRETE MEDIAN BARRIER (TALL WALL) SHALL HAVE DELINEATORS INSTALLED ON BARRIER WALL ORIENTED TOWARDS ONCOMING TRAFFIC AT APPROXIMATELY 25" ABOVE THE ROADWAY.
- PROVIDE SAFETY SLABS WHEN SPECIFIED ON THE PLANS.
- WHEN SPECIFIED ON THE PLANS, THE INVERT IS TO BE SHAPED IN ACCORDANCE WITH STANDARD IS-1. THE COST OF FURNISHING AND PLACING ALL MATERIALS INCIDENTAL TO THE SHAPING IS TO BE INCLUDED IN THE BID PRICE FOR THE STRUCTURE.

TYPE I & III INLET

REINFORCING STEEL

MARK	SIZE	NO.	LENGTH	SPACE
A SEE NOTE 9	#4	6 SEE NOTE 7	L - 2'-6" SEE NOTE 8	AS SHOWN
A-1 SEE NOTE 11	#4	(2XL)+2	5'-6"	12"
B SEE NOTE 9	#3	2X(L-4)	1'-1"	12"
B-1 SEE NOTE 11	#4	11	L + (2'-4")	8"
DOWELS	#4	SEE NOTE 6	1'-0"	6"
F SEE NOTE 9	#5	3 SEE NOTE 10	1'-6"	6"
H	#5	(4XH)+10	3'-2"	12"
H1	#5	(4XH)+8	2'-8"	10"

TYPE - II INLET

A-1	#4	(2XL)+2	5'-6"	12"
B-1	#4	11	L + (2'-4")	8"
H-2	#3	16 SEE NOTE 12	7'-8"	10"
V-1	#5	12	H - (1'-2")	8"
V-2	#4	30	LENGTH = H	8"
A SEE NOTE 15	#4	12 SEE NOTE 14	L - (2'-6") SEE NOTE 8	AS SHOWN
B SEE NOTE 15	#4	4(L-4)	1'-1"	12"
DOWELS	#3	DOUBLE NO. SHOWN FOR TYPE I	1'-0"	6"
F SEE NOTE 15	#5	6 SEE NOTE 13	1'-6"	6"
H	#5	(4 + H)+8	3'-2"	12"
H-1	#5	(4 + H)+16	2'-8"	10"
V	#4	30	LENGTH = H	8"
M-1	#5	5	3'-2"	5"
M	#4	4	1'-8"	12"

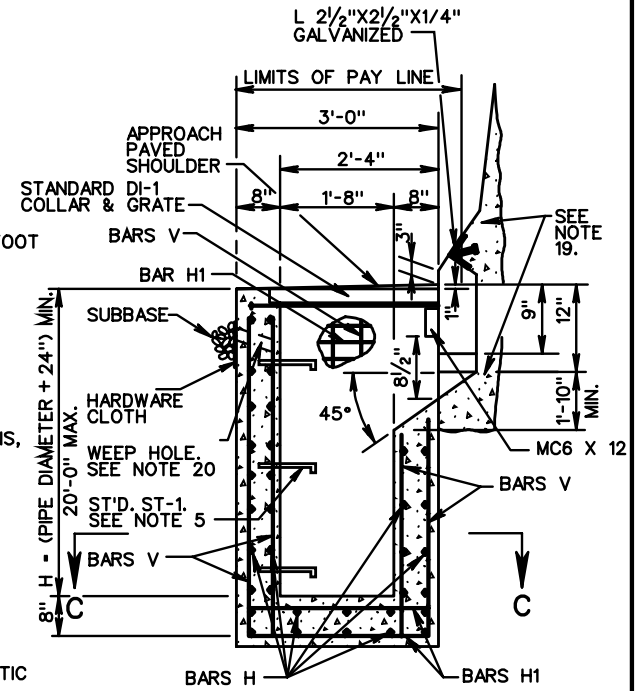
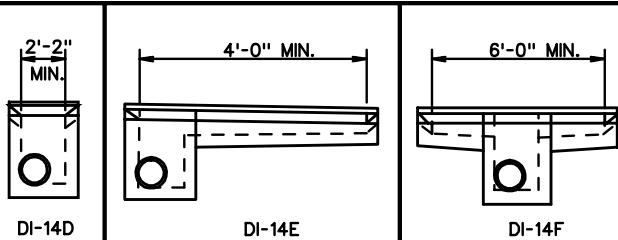

FOR USE ADJACENT TO WALL OR BARRIER WITH SAFETY SHAPE (TYPE III)



ROAD AND BRIDGE STANDARDS

SHEET 2 OF 2

REVISION DATE

104.41

CONCRETE MEDIAN BARRIER DROP INLET

12"-24" PIPE: DEPTH (H)=20' MAX.

VIRGINIA DEPARTMENT OF TRANSPORTATION

SPECIFICATION REFERENCE

233
302

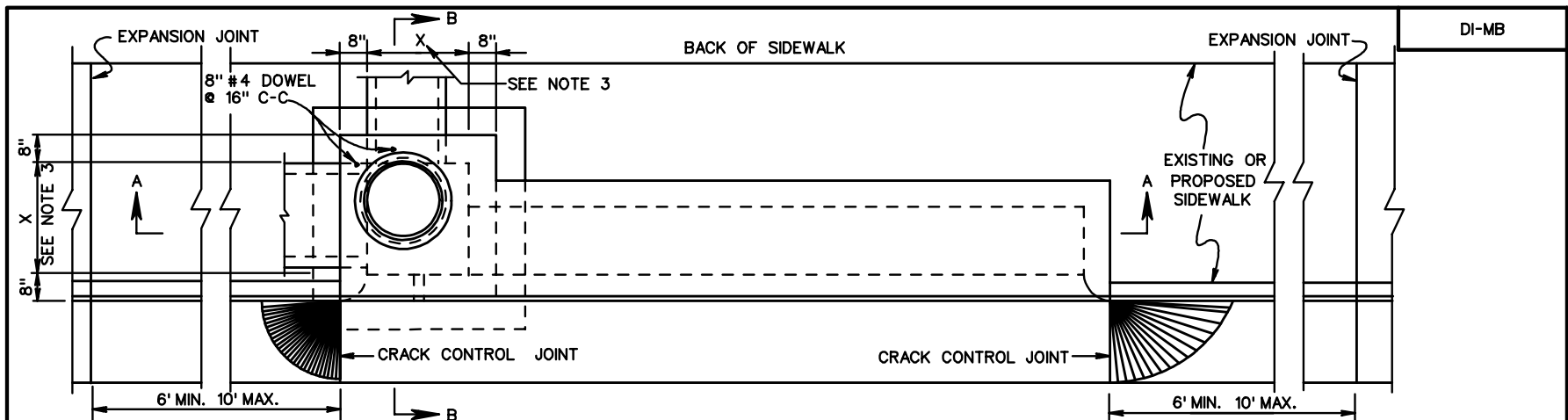

PLAN

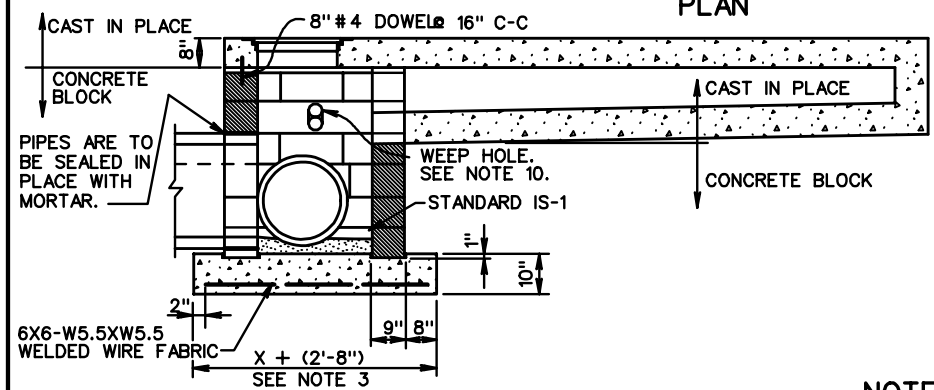

SECTION A-A

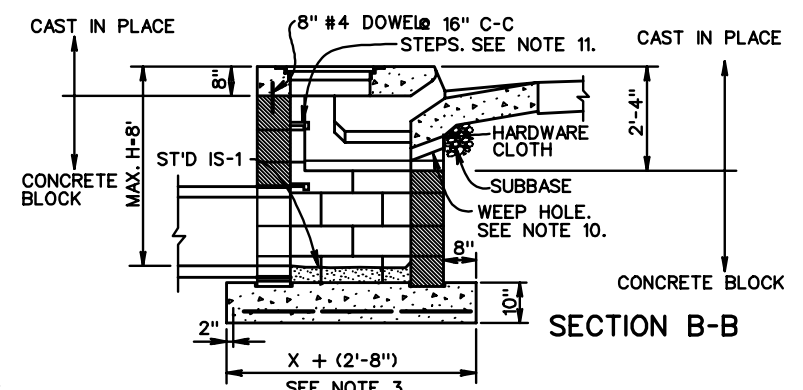

SECTION B-B

NOTES

1. CONCRETE BLOCK IS TO BE EITHER 8" X 8" X 16" OR 8" X 8" X 12" (NOMINAL DIMENSION) SOLID CONCRETE MASONRY BLOCK MEETING THE REQUIREMENTS OF ASTM C-139.
2. DETAILS ABOVE APPLY TO STANDARD DRAWINGS 3A THROUGH 3F AND 4A THROUGH 4F.
3. X EQUALS INTERIOR DIMENSION OF STANDARD DROP INLET SPECIFIED ON PLANS.
4. PARTIAL BLOCK, BRICK OR MORTAR MAY BE USED TO ADJUST TOP TO CURB ELEVATION.
5. REINFORCED CONCRETE FOOTING MAY BE PRECAST OR CAST IN PLACE. LIFTING HOOKS OF FABRICATORS DESIGN ARE TO BE PROVIDED IN PRECAST FOOTING.
6. MAXIMUM DEPTH ALLOWABLE FOR CONCRETE BLOCK CONSTRUCTION IS TO BE 8 FEET.
7. MORTAR JOINTS ON INTERIOR SURFACES ARE TO BE FINISHED FLUSH AND MAY BE LEFT EXTRUDED ON EXTERIOR FACES.
8. THE "H" DIMENSION SHOWN ON THE ST'D'S AND SPECIFIED ON THE PLANS WILL MEASURED FROM THE INVERT OF THE OUTFALL PIPE TO THE TOP OF THE STRUCTURE. PLAN "H" DIMENSIONS ARE APPROXIMATE ONLY FOR ESTIMATING PURPOSES AND THE ACTUAL DIMENSIONS SHALL BE DETERMINED BY THE CONTRACTOR BY FIELD CONDITIONS.
9. WHEN SPECIFIED ON THE PLANS THE INVERT IS TO BE SHAPED IN ACCORDANCE WITH STANDARD PLAN IS-1. THE COST OF FURNISHING AND PLACING ALL MATERIALS INCIDENTAL TO THE SHAPING IS TO BE INCLUDED IN THE BID PRICE FOR THE STRUCTURE.
10. 3" DIAMETER WEEP HOLE SHALL BE LOCATED TO DRAIN SUBBASE MATERIAL. WEEP HOLE WITH 12" X 12" PLASTIC HARDWARE CLOTH 1/4" MESH OR GALVANIZED STEEL WIRE, MINIMUM WIRE DIAMETER 0.03", NUMBER 4 MESH HARDWARE CLOTH ANCHORED FIRMLY TO THE OUTSIDE OF THE STRUCTURE.
11. ALL DETAILS AND DIMENSIONS OF THE PORTION OF THE INLET DESIGNATED "CAST-IN-PLACE" ARE TO BE IN STRICT ACCORDANCE WITH THE ST'D. DRAWING SPECIFIED ON THE PLANS. THIS WILL INCLUDE ALL NOTES, DETAILS OF FRAME AND COVER, GUTTER, AND ANGLE IRON. ALL REINF. STEEL WILL REMAIN AS DETAILED WITH THE FOLLOWING EXCEPTIONS:
 - A) THE VERTICAL LEG OF BARS C WILL BE ELIMINATED.
 - B) BARS G WILL BE ELIMINATED AND REPLACED WITH DOWELS SHOWN HEREON.
12. IN THE EVENT THE INVERT OF THE OUTFALL PIPE IS HIGHER THAN THE BOTTOM OF THE STRUCTURE, THE INVERT OF THE STRUCTURE SHALL BE SHAPED WITH CEMENT MORTAR TO PREVENT STANDING OR PONDING OF WATER IN THE STRUCTURE. THE COST OF FURNISHING AND PLACING ALL MATERIALS INCIDENTALS TO THE SHAPING IS TO BE INCLUDED IN THE BID PRICE FOR THE STRUCTURE.
13. STEPS ARE TO BE PROVIDED WHEN H IS 4'-0" OR GREATER. FOR DETAILS SEE STANDARD ST-1.

SPECIFICATION REFERENCE
302

CONSTRUCTION METHOD FOR CONCRETE MASONRY BLOCK CURB DROP INLET

VIRGINIA DEPARTMENT OF TRANSPORTATION

VDOT	
ROAD AND BRIDGE STANDARDS	
REVISION DATE	SHEET 1 OF 1
104.42	

THIS PAGE INTENTIONALLY LEFT BLANK



ROAD AND BRIDGE STANDARDS

SHEET 1 OF 1

REVISION DATE

104.43

VIRGINIA DEPARTMENT OF TRANSPORTATION

SPECIFICATION
REFERENCE

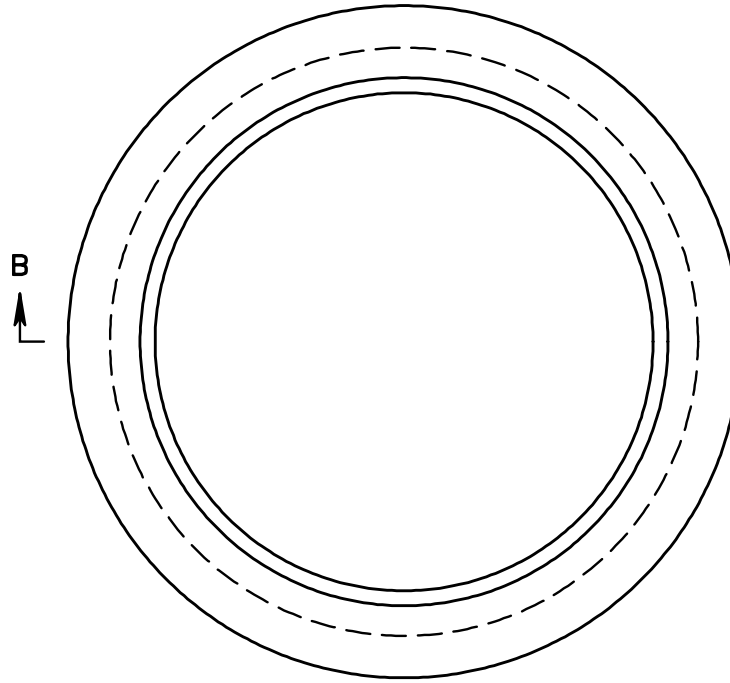

FRAME

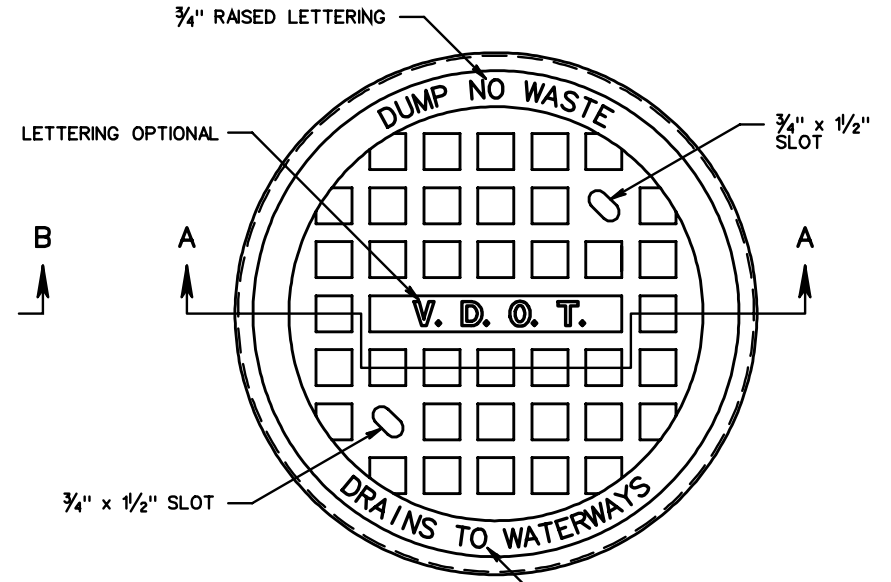

COVER

APPROXIMATE WEIGHT
CAST IRON
FRAME 86 ± 4 LBS.
COVER 83 ± 4 LBS.

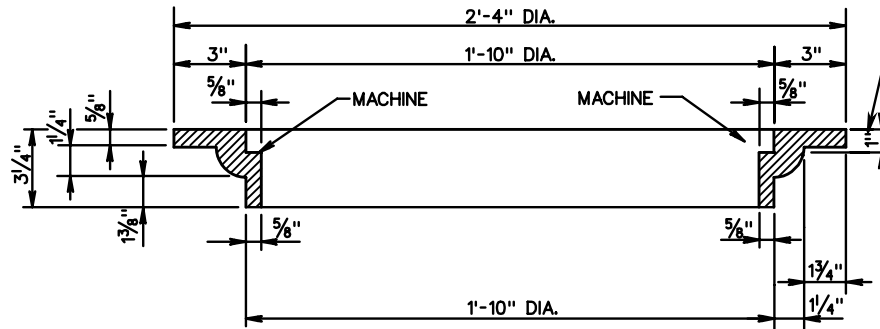

SECTION B-B

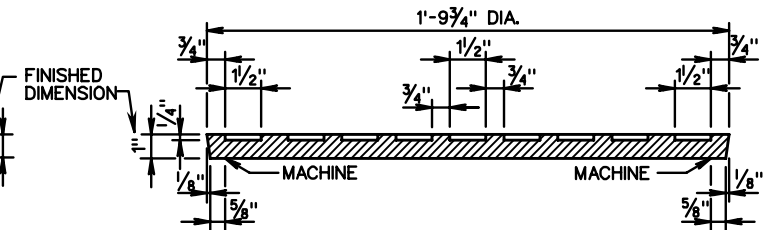

SECTION A-A

NOTES

1. THE LETTERS V.D.O.T. ARE OPTIONAL, IF USED THE LETTERS ARE TO BE CAST IN THE DEPRESSION IN TOP OF THE COVER 1" WIDE AND RAISED 1/4" HIGH AS SHOWN.
2. THE DUMP NO WASTE DRAINS TO WATERWAYS LETTERING IS REQUIRED ON ALL IC-2 COVERS. LOCATION OF LETTERING MAY VARY BY MANUFACTURER.

SPECIFICATION
REFERENCE

224
302

STANDARD INLET AND FRAME COVER

VIRGINIA DEPARTMENT OF TRANSPORTATION

VDOT

ROAD AND BRIDGE STANDARDS

REVISION DATE

SHEET 1 OF 3

105.01

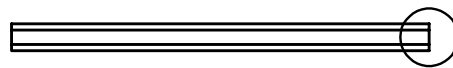
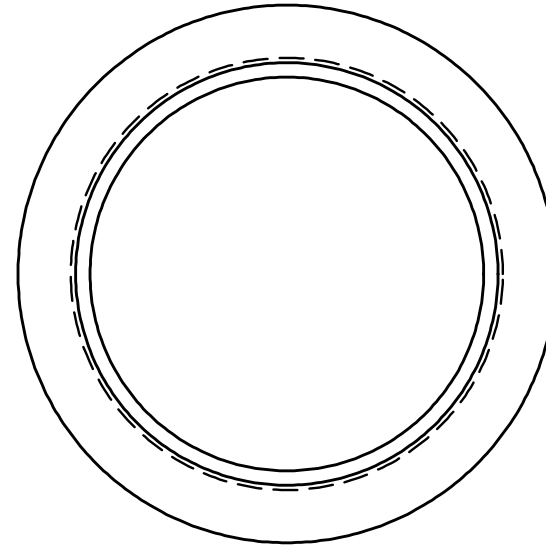
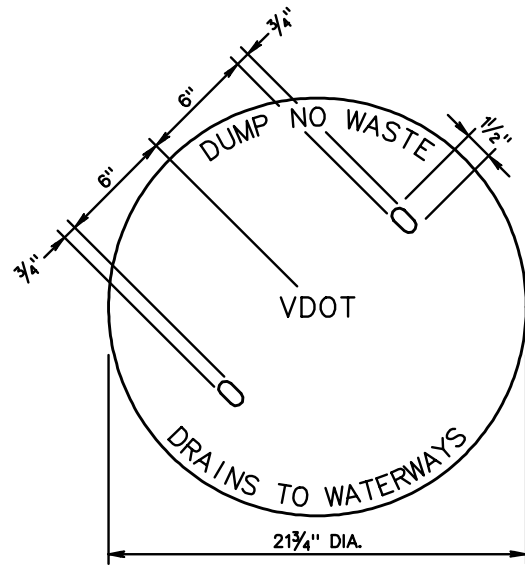

INLET COVER

SEE
DETAIL A

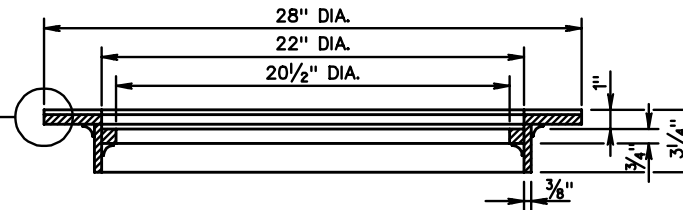

SECTION ϕ
INLET FRAME

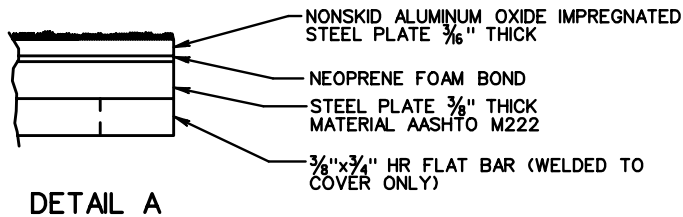

DETAIL A

NOTES

1. STRUCTURAL COMPONENTS SHALL CONFORM TO AASHTO M222.
2. FRAME AND COVER SHALL HAVE A CONTINUOUS FLASH FIT.
3. DUMP NO WASTE DRAINS TO WATERWAYS LETTERING IS REQUIRED ON ALL IC-2 COVERS. LOCATION OF LETTERING MAY VARY BY MANUFACTURER.



ROAD AND BRIDGE STANDARDS

SHEET 2 OF 3

REVISION DATE

105.02

STANDARD INLET FRAME AND COVER

VIRGINIA DEPARTMENT OF TRANSPORTATION

SPECIFICATION
REFERENCE

302

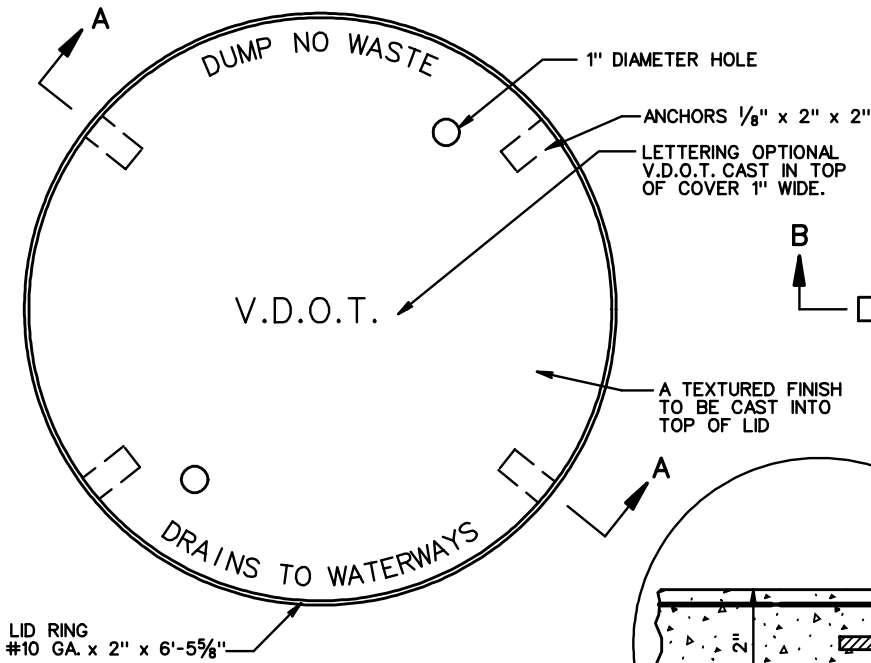

PLAN VIEW COVER

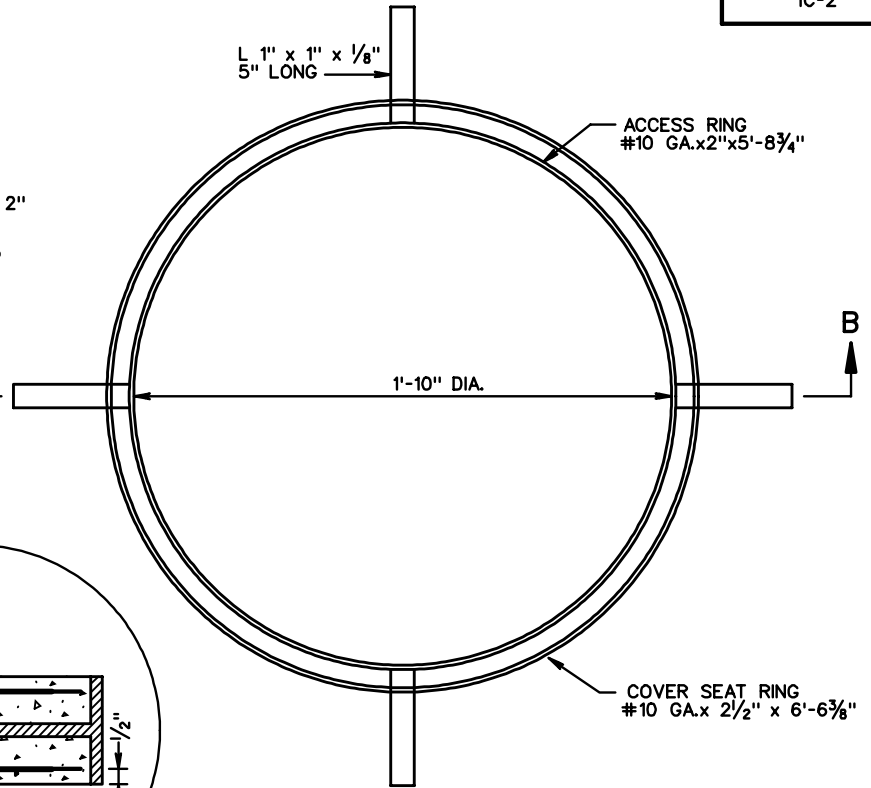

PLAN VIEW FRAME

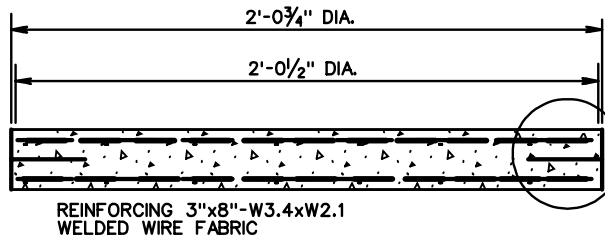

SECTION A-A

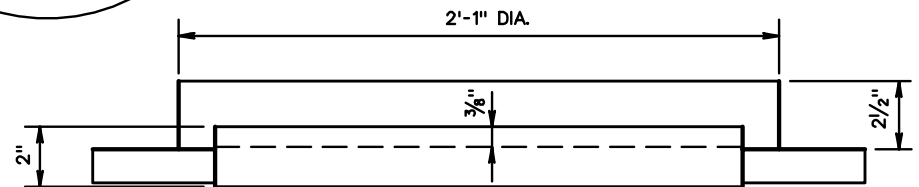

SECTION B-B

NOTES

1. CONCRETE 4000 PSI
2. SUPPLIER MAY FURNISH $\frac{1}{8}$ " STEEL FOR 10 GA.
3. ALL METAL GALVANIZED TO V.D.O.T. STANDARD AND ASTM A 123-73.
4. DUMP NO WASTE DRAINS TO WATERWAYS LETTERING IS REQUIRED ON ALL IC-2 COVERS.
LOCATION OF LETTERING MAY VARY BY MANUFACTURER.

SPECIFICATION
REFERENCE

105
302

PRECAST INLET AND FRAME COVER

VIRGINIA DEPARTMENT OF TRANSPORTATION

VDOT

ROAD AND BRIDGE STANDARDS

REVISION DATE

SHEET 3 OF 3

105.03

THIS PAGE INTENTIONALLY LEFT BLANK



ROAD AND BRIDGE STANDARDS

SHEET 1 OF 1

REVISION DATE

105.04

VIRGINIA DEPARTMENT OF TRANSPORTATION

SPECIFICATION
REFERENCE

SEE STANDARD SL-1 FOR APPLICABILITY OF SAFETY SLABS.

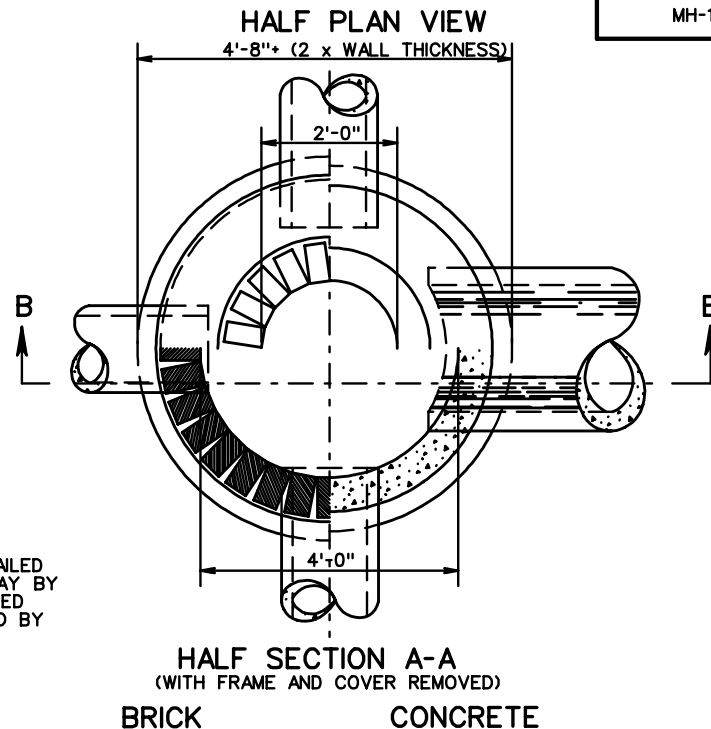
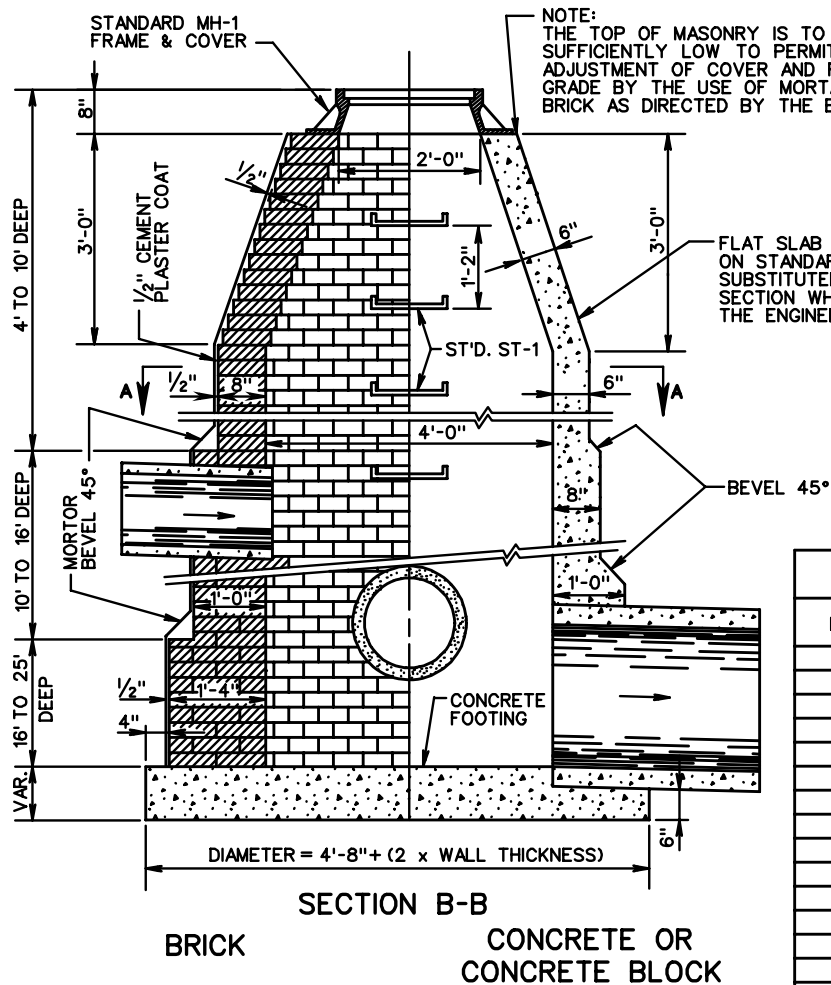

NOTE:
THE TOP OF MASONRY IS TO BE LEFT SUFFICIENTLY LOW TO PERMIT PROPER ADJUSTMENT OF COVER AND FRAME TO GRADE BY THE USE OF MORTAR OR BRICK AS DIRECTED BY THE ENGINEER.

HALF SECTION A-A
(WITH FRAME AND COVER REMOVED)
BRICK CONCRETE

NOTES:

1. QUANTITIES SHOWN ARE FOR MANHOLE WITHOUT PIPES. THE AMOUNT DISPLACED BY PIPES MUST BE DEDUCTED TO OBTAIN TRUE QUANTITIES.
2. A BASE THICKNESS OF 9" WAS USED IN COMPUTING CONCRETE QUANTITIES.
3. INCREMENTS TO BE ADDED FOR EACH ADDITIONAL FOOT OF DEPTH.
4. MATERIALS MAY BE BRICK, CONCRETE OR APPROVED CONCRETE MANHOLE BLOCK.
5. IF BLOCKS ARE USED THE MINIMUM THICKNESS OF SAME IS TO BE 5". OTHER THICKNESSES ARE TO CONFORM TO WALL THICKNESS SHOWN FOR CONCRETE.
6. ALL CONCRETE TO BE CLASS A3.
7. WHEN SPECIFIED ON PLANS THE INVERT IS TO BE SHAPED IN ACCORDANCE WITH STANDARD IS-1. THE COST OF FURNISHING AND PLACING ALL MATERIALS INCIDENTAL TO THE SHAPING IS TO BE INCLUDED IN THE BID PRICE FOR THE STRUCTURE.

DEPTH FEET	BRICK	MANHOLE CONCRETE	CONCRETE MANHOLE
	THOUSANDS	CU. YARDS	CU. YARDS
4	0.5	0.785	1.437
5	0.7	0.785	1.699
6	0.9	0.785	1.961
7	1.0	0.785	2.223
8	1.2	0.785	2.485
9	1.4	0.785	2.747
10	1.6	0.785	3.009
11	1.9	0.970	3.455
12	2.2	0.970	3.817
13	2.5	0.970	4.179
14	2.8	0.970	4.541
15	3.1	0.970	4.903
16	3.4	0.970	5.265
17	4.0	1.173	6.032
INCREMENT	0.45	-	0.582

SPECIFICATION REFERENCE
302

MANHOLE FOR 12" - 48" PIPE CULVERTS

VIRGINIA DEPARTMENT OF TRANSPORTATION



ROAD AND BRIDGE STANDARDS

REVISION DATE SHEET 1 OF 5

106.01

MH-1

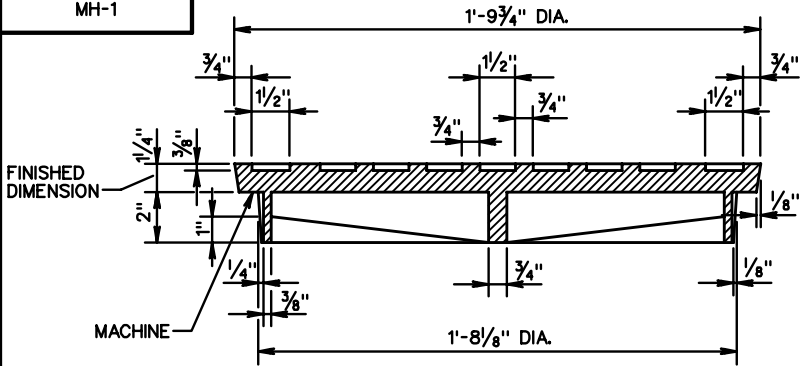

SECTION A-A

THE LETTERS V.D.O.T. ARE OPTIONAL
IF USED THE LETTERS ARE TO BE
CAST IN THE DEPRESSION IN TOP OF
COVER 1\"/>

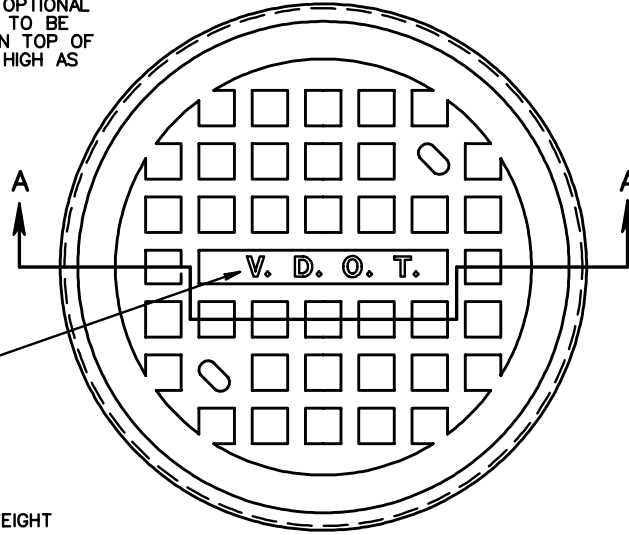

TOP

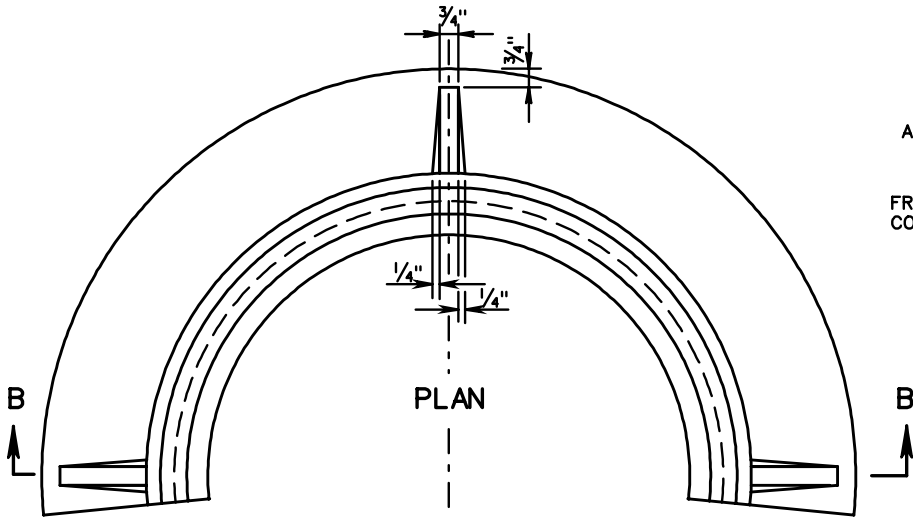

PLAN

APPROXIMATE WEIGHT
CAST IRON
FRAME 239 ± 12 LBS.
COVER 137 ± 7 LBS.

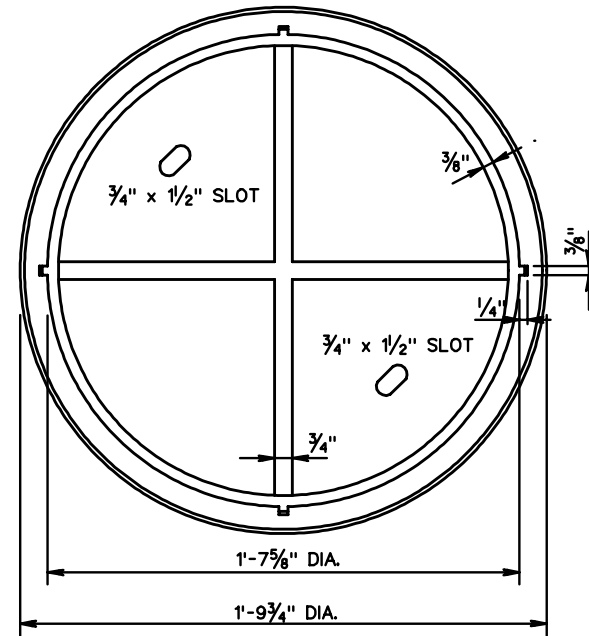

BOTTOM

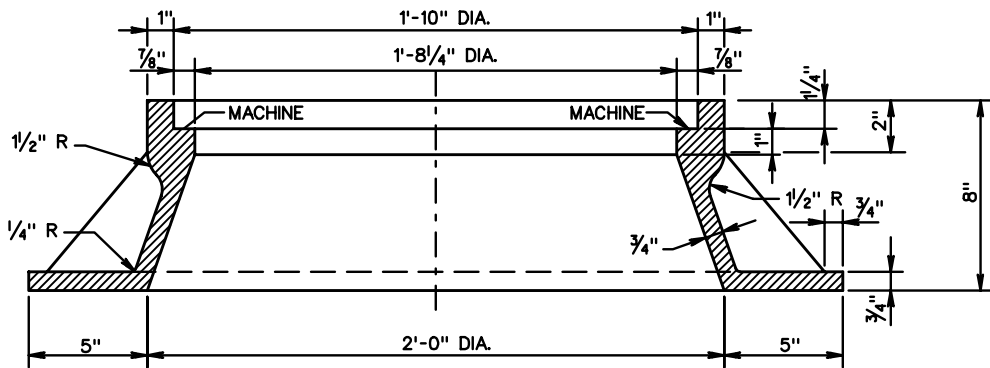

SECTION B-B



ROAD AND BRIDGE STANDARDS

SHEET 2 OF 5

REVISION DATE

106.02

STANDARD MANHOLE FRAME AND COVER

VIRGINIA DEPARTMENT OF TRANSPORTATION

SPECIFICATION
REFERENCE

224
302

NOTES:
 THE LETTERS V.D.O.T. ARE OPTIONAL,
 IF USED THE LETTERS ARE TO BE
 CAST IN THE DEPRESSION IN TOP OF
 COVER 1" WIDE AND RAISED $\frac{3}{8}$ " HIGH
 AS SHOWN.

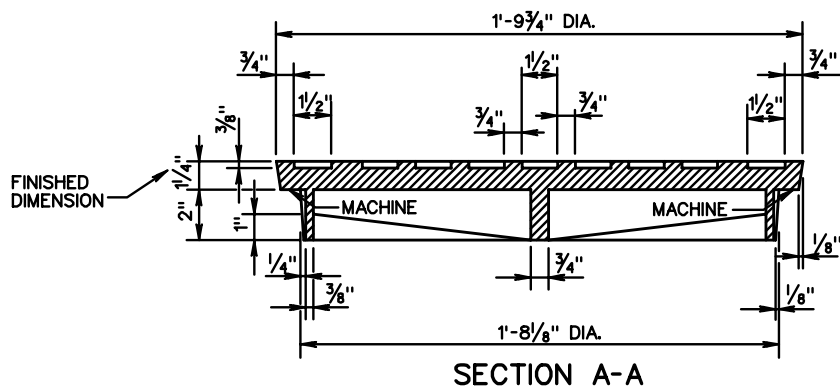

LETTERING
 OPTIONAL

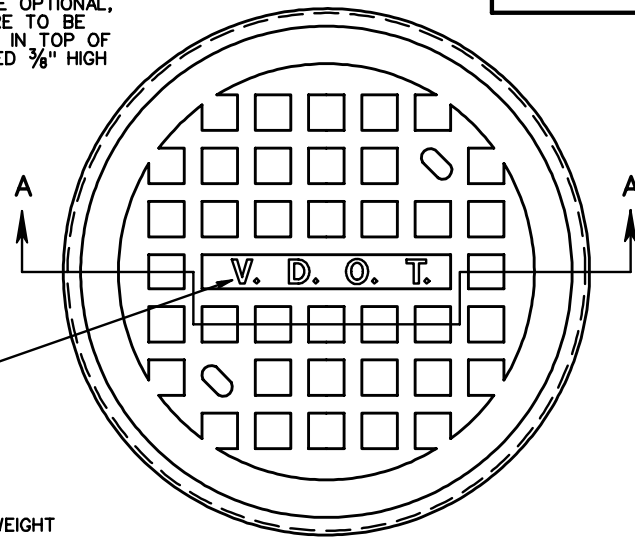

TOP

APPROXIMATE WEIGHT
 CAST IRON
 COVER 137 ± 7 LBS.
 FRAME 235 ± 12 LBS.

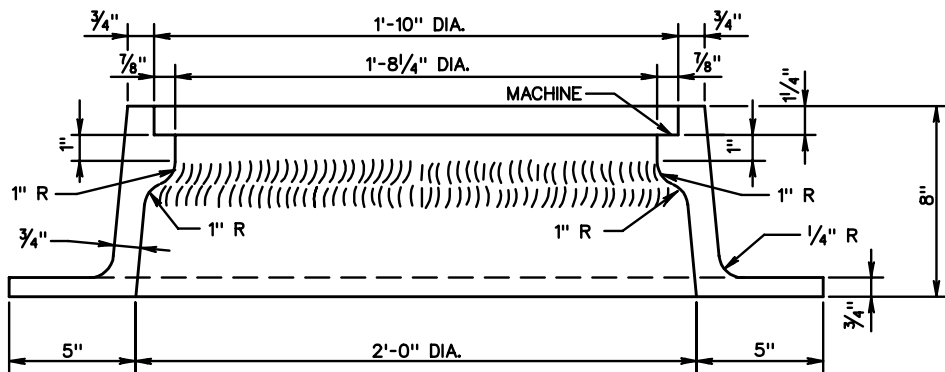

FRAME SECTION AT MID POINT

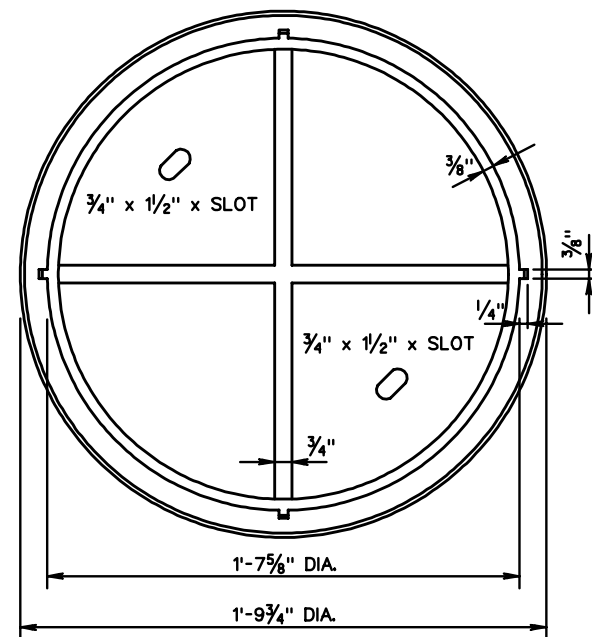

BOTTOM

SPECIFICATION
 REFERENCE

224
 302

STANDARD MANHOLE FRAME AND COVER

VIRGINIA DEPARTMENT OF TRANSPORTATION

VDOT

ROAD AND BRIDGE STANDARDS

REVISION DATE

SHEET 3 OF 5

106.03

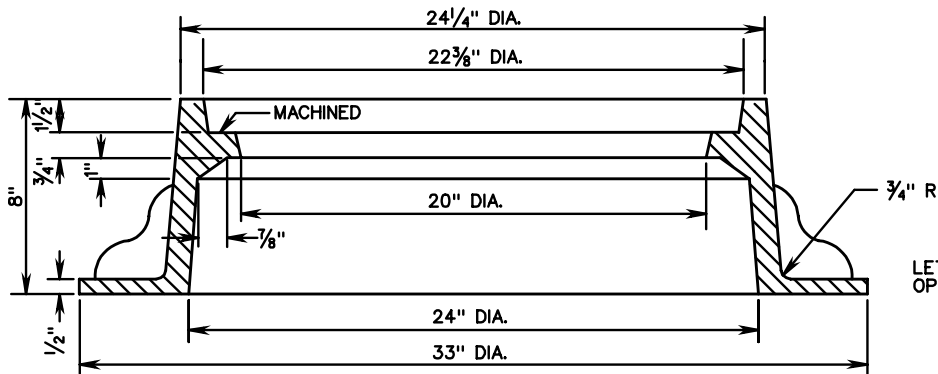
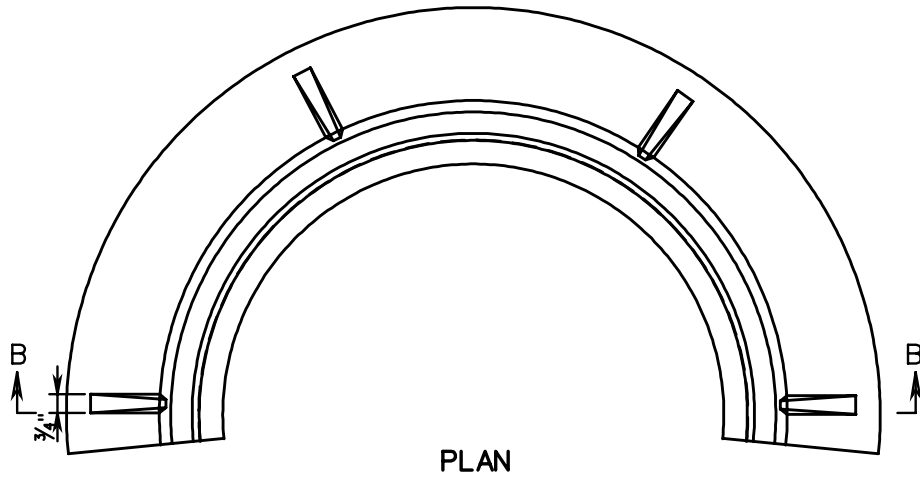

EITHER COVER A OR B MAY BE USED WITH FRAME.
 APPROX. WEIGHT COVER 170 LBS. ±

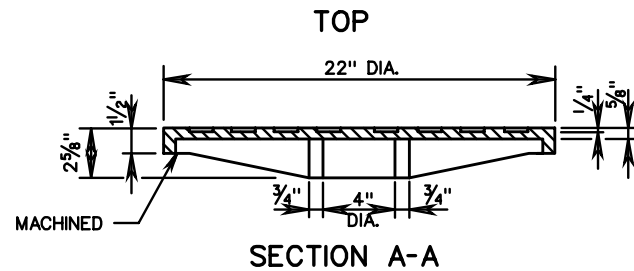
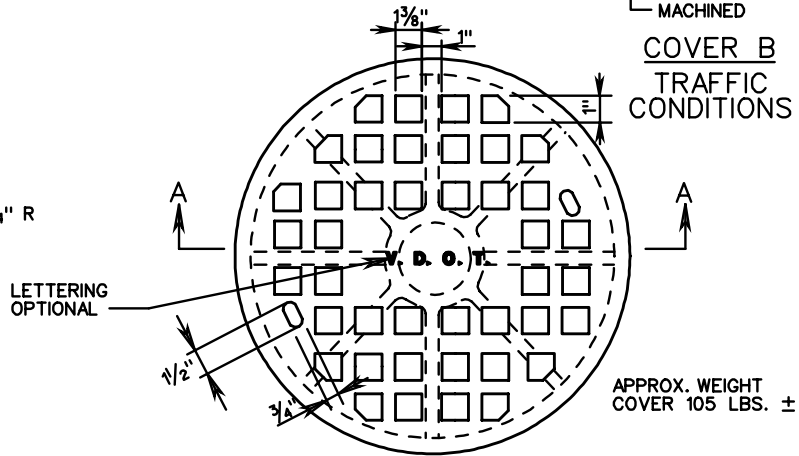
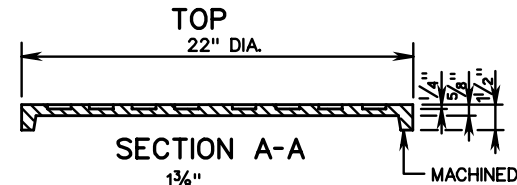
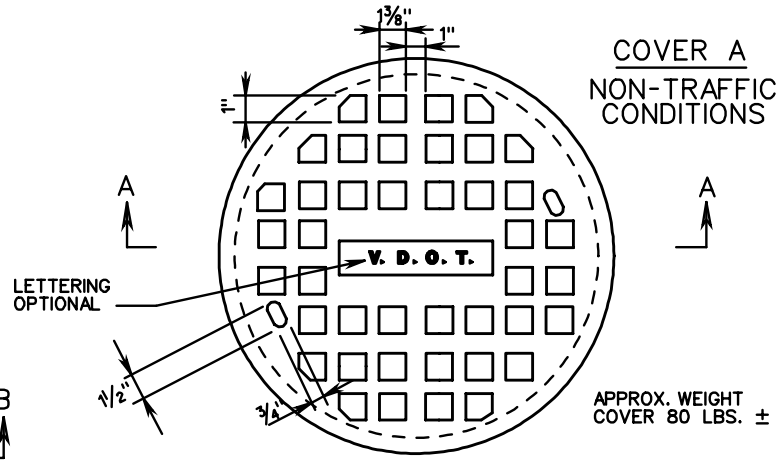

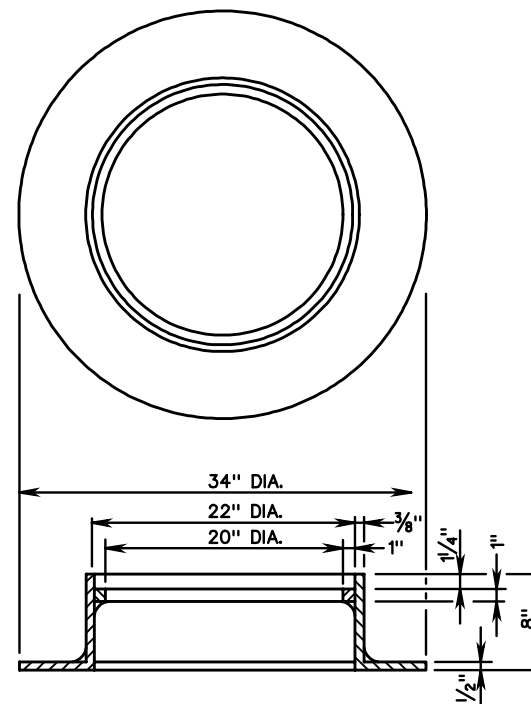
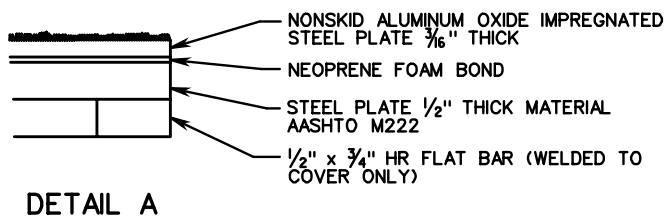
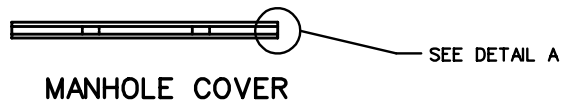
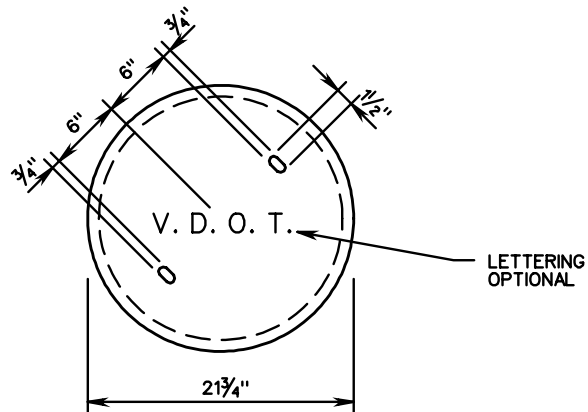

NOTES:
 STRUCTURAL COMPONENTS SHALL CONFORM TO AASHTO M222.
 FRAME AND COVER SHALL HAVE A CONTINUOUS FLUSH FIT.

SPECIFICATION REFERENCE
302

STANDARD MANHOLE AND COVER

VIRGINIA DEPARTMENT OF TRANSPORTATION

VDOT	
ROAD AND BRIDGE STANDARDS	
REVISION DATE	SHEET 5 OF 5
	106.05

NOTES:
 THE LETTERS V.D.O.T. ARE OPTIONAL,
 IF USED THE LETTERS ARE TO BE
 CAST IN THE DEPRESSION IN TOP OF
 COVER 1" WIDE AND RAISED $\frac{3}{8}$ " HIGH
 AS SHOWN.

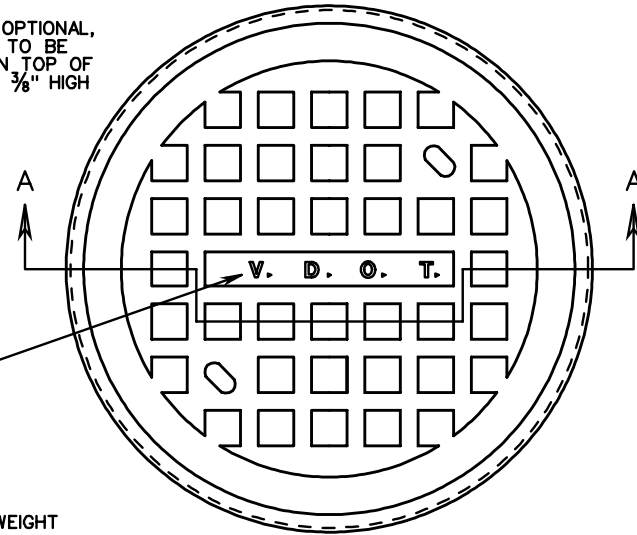
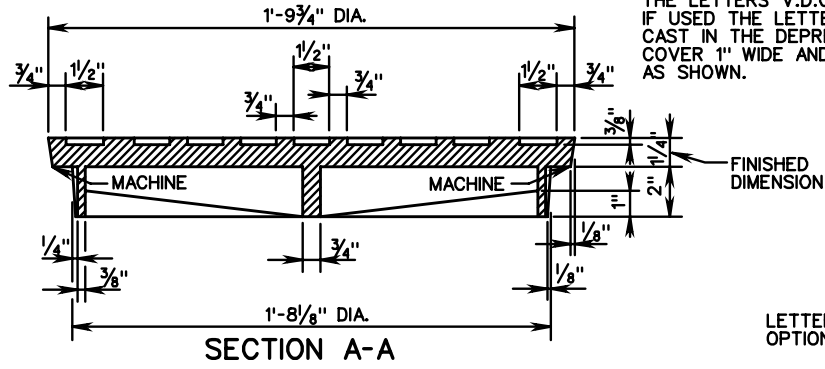

APPROXIMATE WEIGHT
 CAST IRON
 FRAME 174 ± 9 LBS.
 COVER 137 ± 7 LBS.

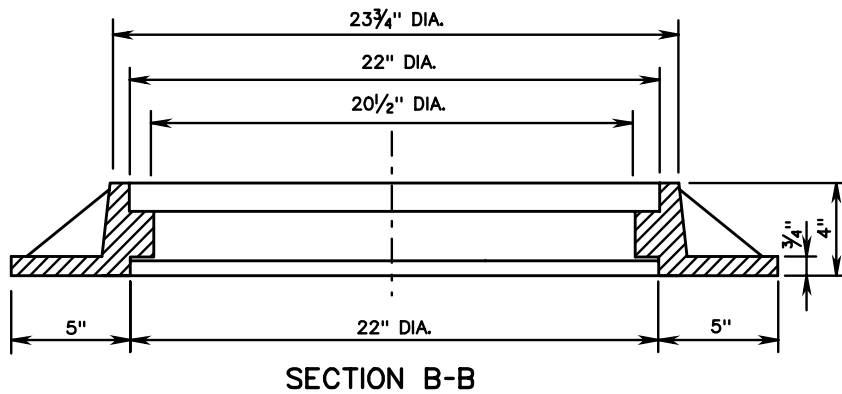
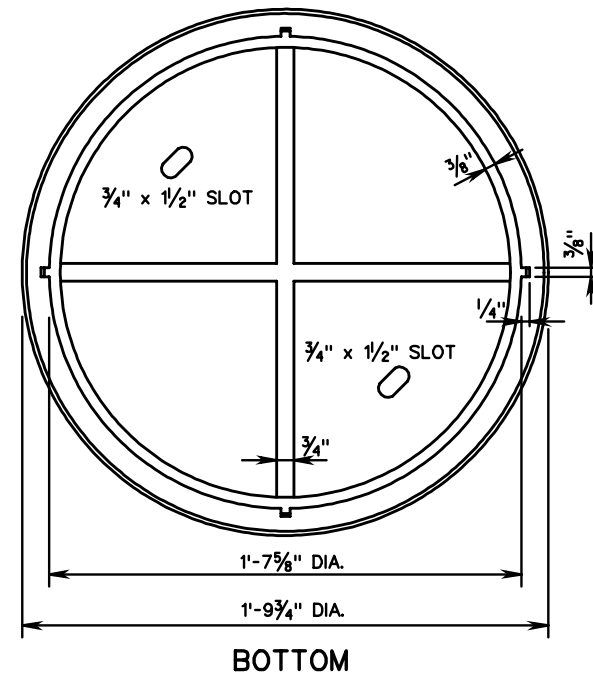
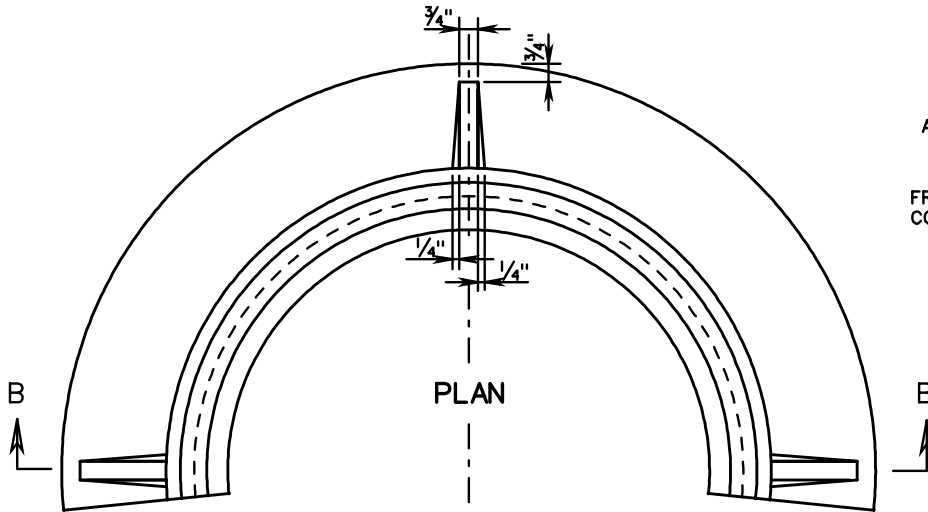

STANDARD MANHOLE FRAME AND COVER

FOR DETAILS OF ALL COMPONENT PARTS AND
 "GENERAL NOTES- PRECAST" SEE SHEETS
 103.01-103.11

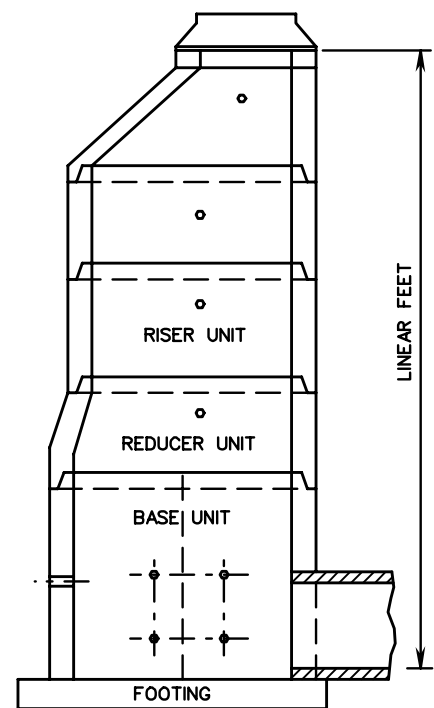
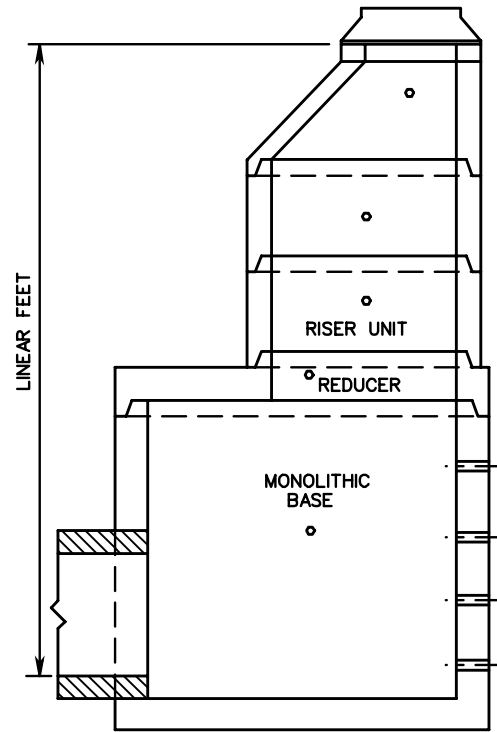
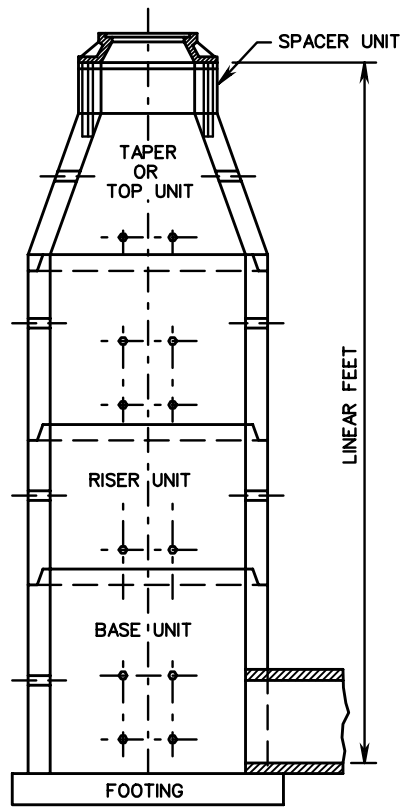

SPECIFICATION REFERENCE
105 302

PRECAST MANHOLE
 VIRGINIA DEPARTMENT OF TRANSPORTATION

VDOT	
ROAD AND BRIDGE STANDARDS	
REVISION DATE	SHEET 1 OF 1
	106.07

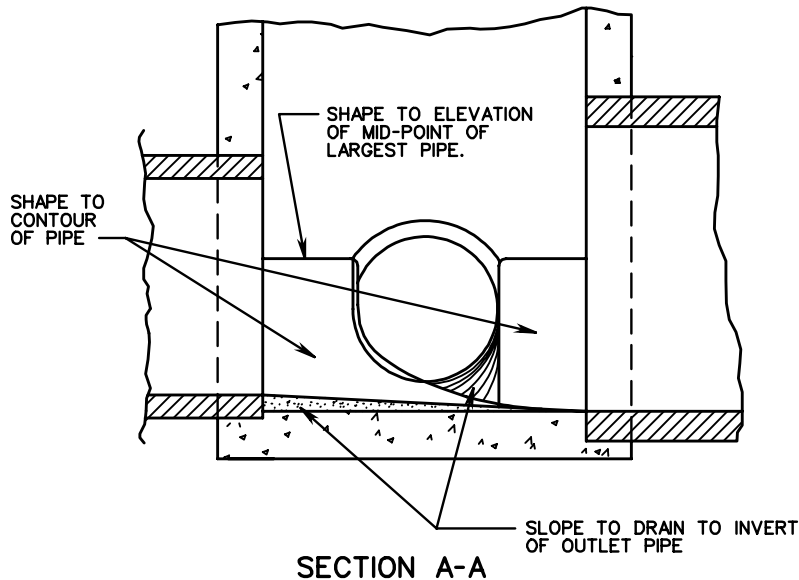
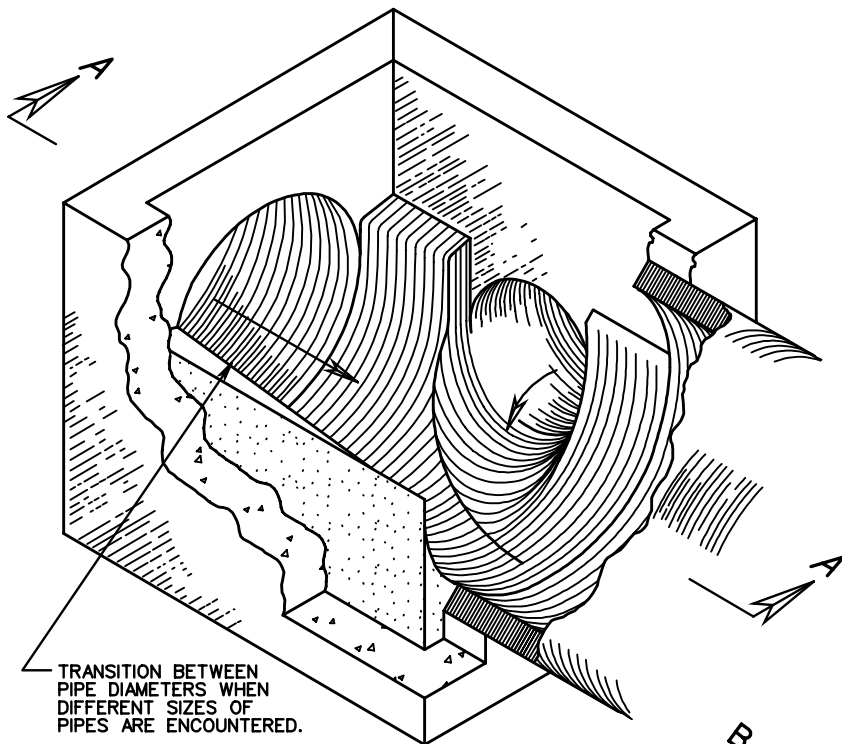

METHOD OF TREATMENT IN DROP INLETS

NOTES:
SHAPING OF MANHOLE AND INLET INVERTS IN ACCORDANCE WITH THIS DRAWING IS TO APPLY TO THOSE STRUCTURES SPECIFIED ON PLANS OR WHERE INVERT OF PIPE IS ABOVE INVERT OF STRUCTURE.

MANHOLE OR DROP INLET IS TO BE FORMED AND CONSTRUCTED IN ACCORDANCE WITH APPLICABLE STANDARD OR SPECIAL DRAWING. THE INVERT SHAPING AS DETAILED HEREON IS TO CONSIST OF A PORTLAND CEMENT CONCRETE MIX CONFORMING TO CLASS A3 OR CLASS C1, EXCEPT THAT 25% OF COARSE AGGREGATE MAY BE UP TO 4" IN DIAMETER AND CONSIST OF STONE, BROKEN BRICK, BROKEN CONCRETE OR BROKEN CONCRETE BLOCK. THE SURFACE SHALL BE LEFT SMOOTH BY MEANS OF HAND TROWELLING. NONE OF THE COARSE AGGREGATE SHALL REMAIN EXPOSED.

DETAILS OF INVERT SHAPING AS SHOWN HEREON ARE FOR EXAMPLE PURPOSES ONLY. EACH MANHOLE OR DROP INLET IS TO BE SHAPED INDIVIDUALLY TO BEST FIT THE PARTICULAR INLET AND OUTLET CONFIGURATION AND FLOW LINES.

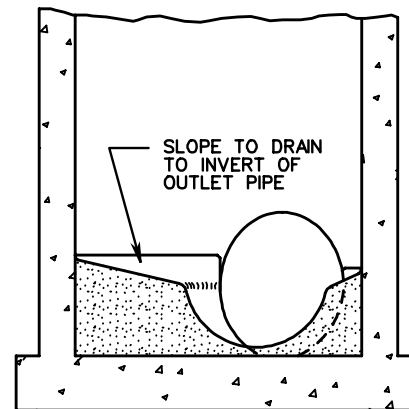
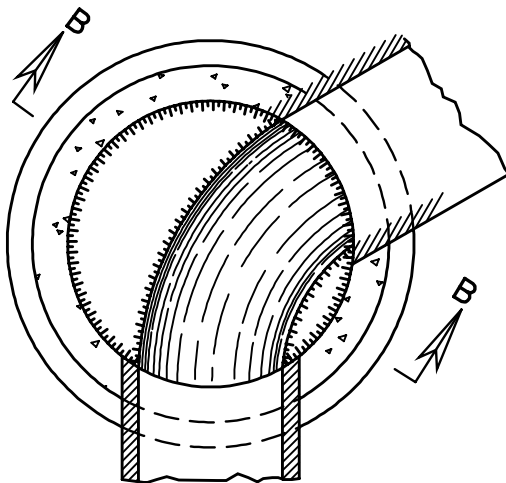

METHOD OF TREATMENT IN MANHOLES

STANDARD METHOD OF SHAPING MANHOLE & INLET INVERTS

VIRGINIA DEPARTMENT OF TRANSPORTATION

SPECIFICATION
REFERENCE

302



ROAD AND BRIDGE STANDARDS

SHEET 1 OF 1

REVISION DATE

106.08

NO. 6 GALVANIZED STEEL STEP

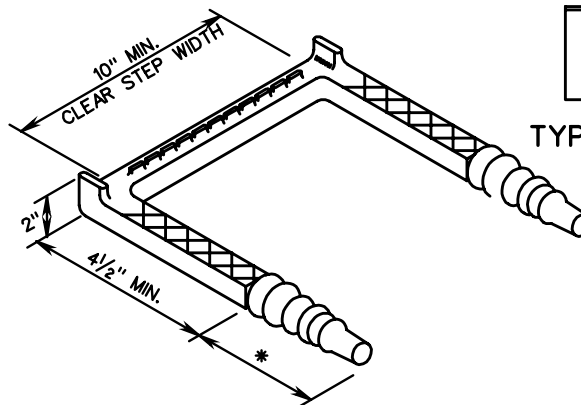
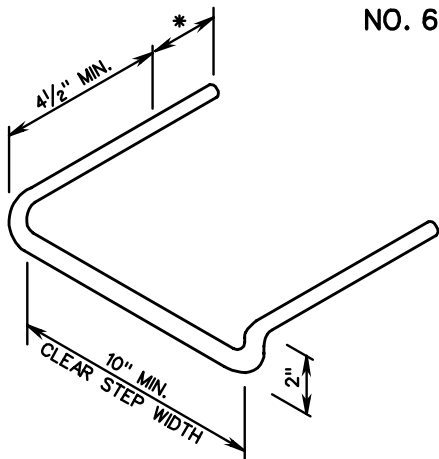

#4, GRADE 60, REINFORCING ROD ENCASED IN A CORROSION RESISTANT RUBBER OR OTHER MATERIAL APPROVED BY THE ENGINEER. (DIMENSION MAY VARY WITH MANUFACTURER'S DESIGN)

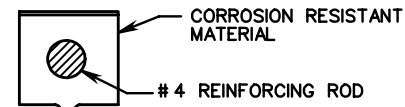

TYPICAL SECTION

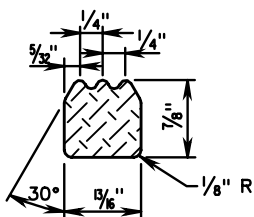

TYPICAL SECTION
(DIMENSIONS MAY VARY WITH MANUFACTURER'S DESIGN)

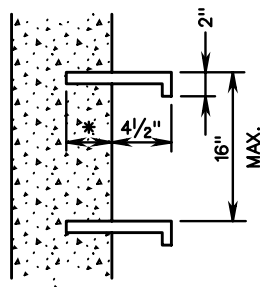

* MINIMUM OF 3" EMBEDMENT

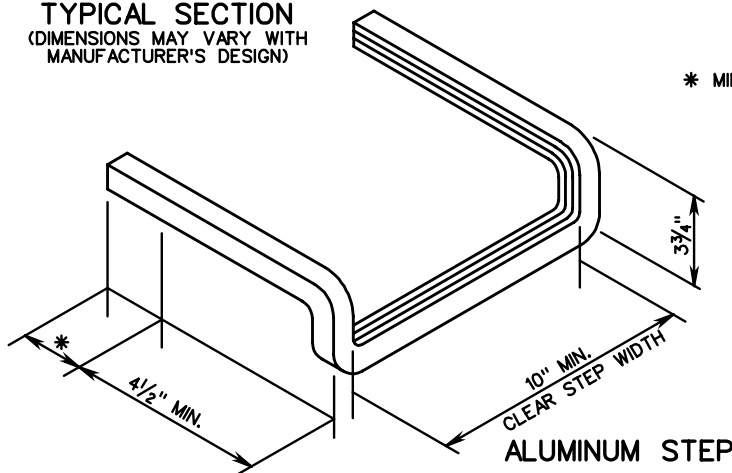

ALUMINUM STEP

NOTES:
STEPS WILL BE REQUIRED IN ALL STRUCTURES WITH A DEPTH OF 4'-0" OR GREATER UNLESS OTHERWISE NOTED ON THE PLANS.

ALL STEPS SHALL PROTRUDE 4 1/2" FROM INSIDE FACE OF STRUCTURE WALL.

MAXIMUM STEP SPACING TO BE 16" C-C.

STEPS SHALL WITHSTAND A MINIMUM FORCE OF 300 POUNDS WHEN EXTENDED 4 1/2" FROM THE FACE OF THE SUPPORT.

STEPS ARE TO BE VERTICALLY ALIGNED AND UNIFORMALLY SPACED FOR THE ENTIRE DEPTH OF ANY STRUCTURE.

IN PRECAST UNITS STEPS MAY BE CAST IN PLACE, MORTARED INTO HOLES PROVIDED BY THE FABRICATOR, OR DRIVEN.

STEPS DIFFERING IN DIMENSIONS, CONFIGURATION, OR MATERIALS FROM THOSE SHOWN MAY ALSO BE USED PROVIDED THEY MEET THE MINIMUM REQUIREMENTS SHOWN HEREON AND THE CONTRACTOR HAS FURNISHED THE ENGINEER WITH DETAILS AND CERTIFIED TEST REPORTS OF THE PROPOSED SUBSTITUTE AND HAS RECEIVED WRITTEN APPROVAL FROM THE ENGINEER FOR THE USE OF SUCH STEPS.

ALL STEPS INSTALLED SHALL BE PROVIDED WITH SLIP-RESISTANT SURFACES SUCH AS BUT NOT LIMITED TO, CORRUGATED KNURLED, OR DIMPLED SURFACES.

ALUMINUM STEPS SHALL BE FABRICATED IN ACCORDANCE WITH ASTM B221, ALLOY 6005-T5. THAT PORTION OF THE STEP ENCASED IN MASONRY SHALL BE UNIFORMLY COATED WITH A BITUMINOUS, SOLVENT TYPE, ASBESTOS FILLED ALUMINUM PIGMENTED COATING CONFORMING TO FEDERAL SPECIFICATION TC-C-00498A.

SPECIFICATION REFERENCE

STANDARD STEP

VIRGINIA DEPARTMENT OF TRANSPORTATION

VDOT

ROAD AND BRIDGE STANDARDS

REVISION DATE

SHEET 1 OF 1

106.09

JB-1

B

OPENING IN TOP SLAB OF CHAMBER TO BE CIRCULAR WHEN USED WITH TYPE A OR C TOWERS

TWO BARS K TO BE USED IN EACH CORNER WITH CIRCULAR OPENING IN TOP.
1 BAR F E.F.-E.S.

GALVANIZED S5X10 TO BE PLACED UNDER TOP SLAB AND EXTENDED INTO SIDE WALLS TO WITHIN 2" OF OUTSIDE FACE.

(BARS A @ 8" C-C N.F.
BARS G @ 8" C-C F.F.)

BARS J @ 6" C-C E.F.

"W" DENOTES BOTH THE INTERNAL CHAMBER WIDTH ALONG THE NARROW AXIS AND THE DIMENSION OF THE OPENING IN THE TOP SLAB OF CHAMBER

OPENING IN TOP SLAB OF CHAMBER TO BE SQUARE WHEN USED WITH TYPE B TOWERS

B

PLAN VIEW

(TOP SLAB REINFORCEMENT)

TYPE A, B, AND C TOWER. SEE SHEET 3 OF 4 FOR DETAILS.

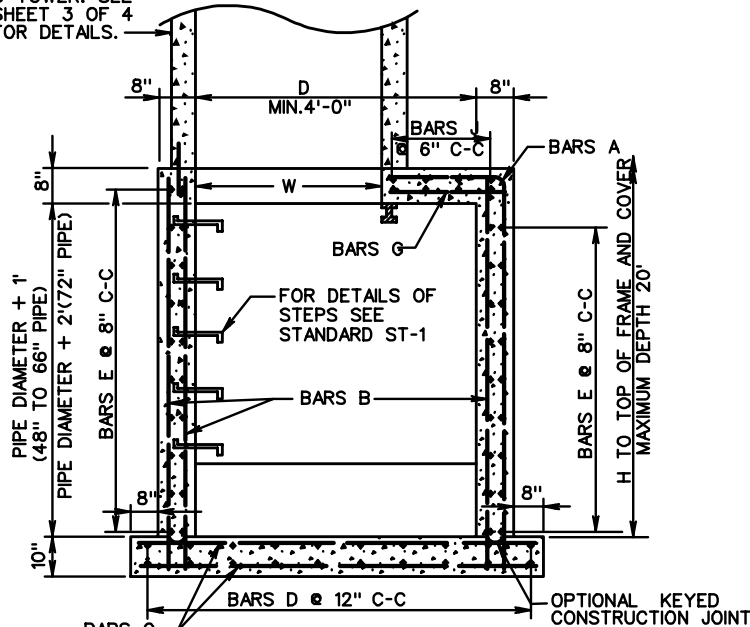

SECTION A-A

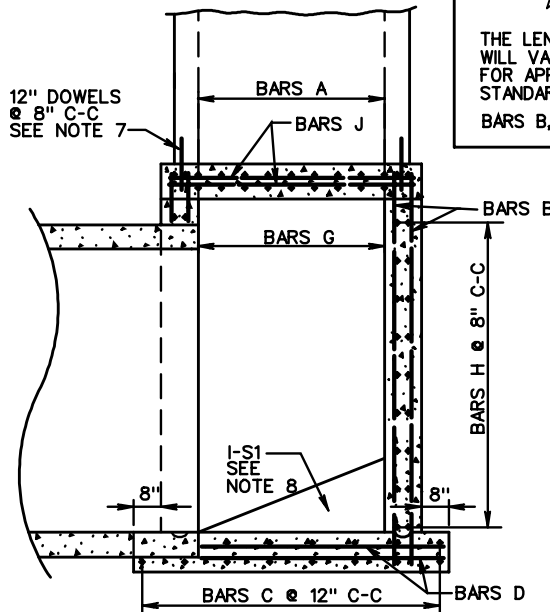

SECTION B-B

NOTES:

1. ALL REINFORCING STEEL TO BE #6 BARS WITH A MINIMUM 1/2" CONCRETE COVER.
2. ANY REINFORCING BARS IN CONFLICT WITH PIPE SHELLS ARE TO BE CUT A MINIMUM OF 1/2" FROM PIPE.
3. FOR DETAILS METHOD OF TURNING ANGLES AND APPROXIMATE QUANTITIES SEE SHEET 2 OF 4.
4. PRECAST CHAMBERS OF THE BOLT TOGETHER TYPE MAY BE SUBSTITUTED WHEN APPROVED ON AN INDIVIDUAL BASIS.
5. ALL CONCRETE TO BE CLASS A3 IF CAST IN PLACE, 4000 PSI IF PRECAST.
6. THIS ITEM MAY BE PRECAST OR CAST IN PLACE.
7. ELIMINATE DOWELS WHEN PRECAST TYPE A TOWER ARE ELECTED.
8. WHEN SPECIFIED ON PLANS INVERT IS TO BE SHAPED IN ACCORDANCE WITH STANDARD IS-1. THE MATERIALS INCIDENTAL TO THE SHAPING ARE NOT TO BE MEASURED OR PAID SEPARATELY BUT THE COST OF SAME IS TO BE INCLUDED IN THE PRICE BID PER CUBIC YARD OF JUNCTION BOX CONCRETE

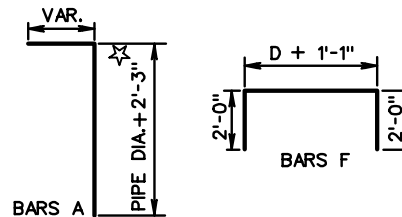

☆ INCREASE INDICATED DIMENSION BY 1' FOR USE WITH 72" PIPE.

THE LENGTH OF ALL BARS AND THE NUMBER REQUIRED WILL VARY WITH THE SIZE OF CHAMBER. FOR APPROXIMATE WEIGHT SEE SHEET 2 AND 4 OF THIS STANDARD.

BARS B, C, E, G, H, AND J ARE STRAIGHT.



ROAD AND BRIDGE STANDARDS

SHEET 1 OF 4

REVISION DATE

106.10

JUNCTION BOX CHAMBER DETAILS FOR 48" - 72" PIPE CULVERTS MAX. DEPTH (H) = 20'

VIRGINIA DEPARTMENT OF TRANSPORTATION

SPECIFICATION REFERENCE

105
233
302

LOCATION OF CHAMBER TO FIT VARIOUS FLOW LINE ANGLES

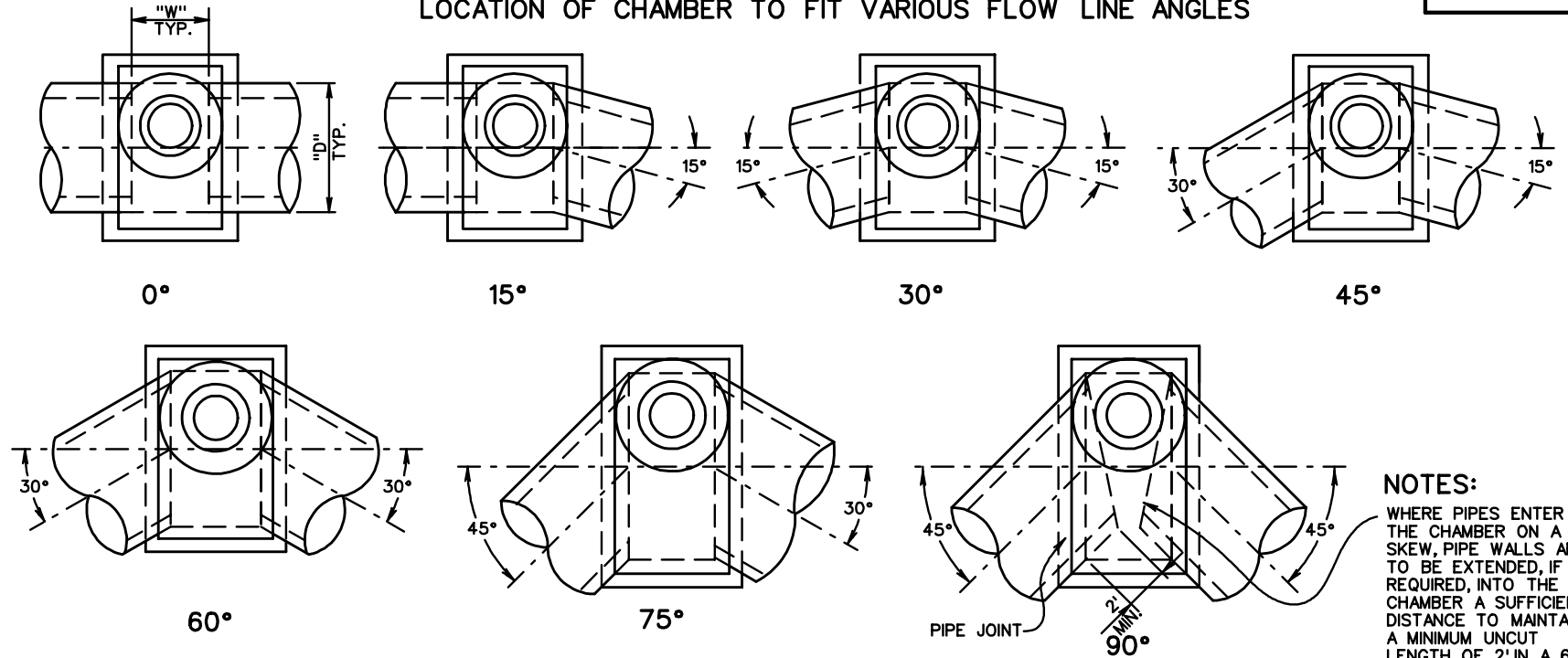

NOTES:
 WHERE PIPES ENTER THE CHAMBER ON A SKEW, PIPE WALLS ARE TO BE EXTENDED, IF REQUIRED, INTO THE CHAMBER A SUFFICIENT DISTANCE TO MAINTAIN A MINIMUM UN CUT LENGTH OF 2' IN A 6' PIPE SECTION.

QUANTITIES FOR CHAMBER *

PIPE SIZE	ANGLE OF TURN												
	0°			1° - 30°			31° - 60°			61° - 90°			
	DIM. D	CU. YDS. CONC.	LBS. REINF. STEEL	DIM. D	CU. YDS. CONC.	LBS. REINF. STEEL	DIM. D	CU. YDS. CONC.	LBS. REINF. STEEL	DIM. D	CU. YDS. CONC.	LBS. REINF. STEEL	
TYPE A "W" = 4'-0"	48"	4'-10"	4.56	1293	5'-0"	4.65	1317	5'-7"	4.99	1412	6'-10"	5.72	1602
	54"	5'-5"	5.16	1466	5'-7"	5.26	1558	6'-3"	5.10	1617	7'-8"	6.53	1798
	60"	6'-0"	5.80	1657	6'-3"	5.96	1794	6'-11"	6.38	1831	8'-6"	7.38	2064
	66"	6'-7"	6.46	2028	6'-10"	6.63	2069	7'-7"	7.12	2220	9'-4"	8.27	2510
TYPE B "W" = 3'-0"	48"	4'-10"	4.06	1149	5'-0"	4.15	1173	5'-7"	4.46	1274	6'-10"	5.12	1440
	54"	5'-5"	4.61	1308	5'-7"	4.70	1373	6'-3"	5.07	1452	7'-8"	5.85	1619
	60"	6'-0"	5.19	1487	6'-3"	5.33	1531	6'-11"	5.71	1651	8'-6"	6.63	1925
	66"	6'-7"	5.79	1815	6'-10"	5.94	1934	7'-7"	6.40	2058	9'-4"	7.45	2359
TYPE C "W" = 2'-0"	48"	4'-10"	3.53	1030	5'-0"	3.61	1052	5'-7"	3.88	1133	6'-10"	4.47	1294
	54"	5'-5"	4.02	1177	5'-7"	4.10	1236	6'-3"	4.43	1305	7'-8"	5.14	1454
	60"	6'-0"	4.54	1337	6'-3"	4.67	1381	6'-11"	5.02	1484	8'-6"	5.85	1710
	66"	6'-7"	5.09	1592	6'-10"	5.22	1674	7'-7"	5.64	1789	9'-4"	6.59	2062
	72"	7'-2"	6.19	1835	7'-5"	6.34	1885	8'-3"	6.86	2050	10'-2"	8.05	2355

* QUANTITIES SHOWN ARE FOR CHAMBER WITHOUT PIPES. PIPE DISPLACEMENT OF CONCRETE AND STEEL MUST BE DEDUCTED TO OBTAIN TRUE QUANTITIES. SEE SHEET 4 OF 4.

CHAMBER AND TOWER QUANTITIES FOR CONCRETE AND REINFORCING STEEL MUST BE ADDED TO OBTAIN TOTALS.

"W"	STRUCT. STEEL
2'-0"	30 Lbs.
3'-0"	40 Lbs.
4'-0"	50 Lbs.

SPECIFICATION REFERENCE
105
233
302

JUNCTION BOX DETAILS FOR ANGULAR CONNECTIONS OF 48" - 72" PIPE CULVERTS

VIRGINIA DEPARTMENT OF TRANSPORTATION



ROAD AND BRIDGE STANDARDS

REVISION DATE SHEET 2 OF 4

106.11

DETAILS OF TOWERS

TYPE A

TO BE USED WHEN VERTICAL DISTANCE BETWEEN GRADE AND INVERT OF PIPE IS PIPE DIAMETER PLUS 5'-4" OR GREATER (SEE NOTE 3).

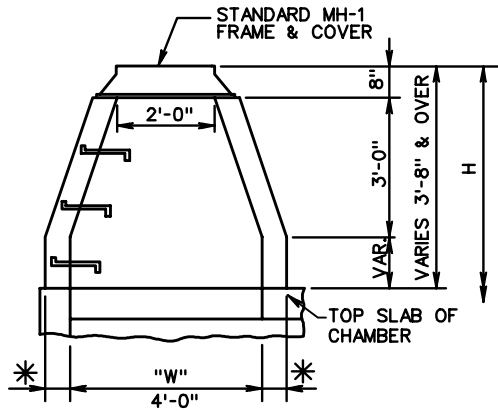

* WALL THICKNESS TO BE 6" TO A DEPTH OF 10' AND 8" OVER 10'.

SECTION A-A

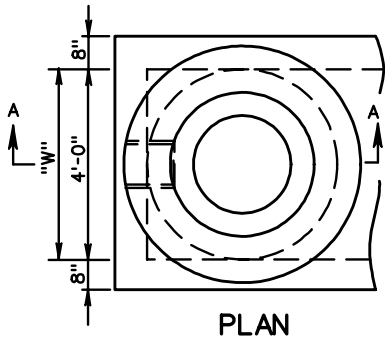

TYPE B

TO BE USED WHEN VERTICAL DISTANCE BETWEEN GRADE AND INVERT OF PIPE IS PIPE DIAMETER PLUS 3'-2" TO 5'-4" (SEE NOTE 3).

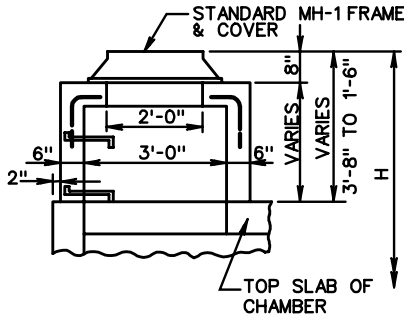

SECTION A-A

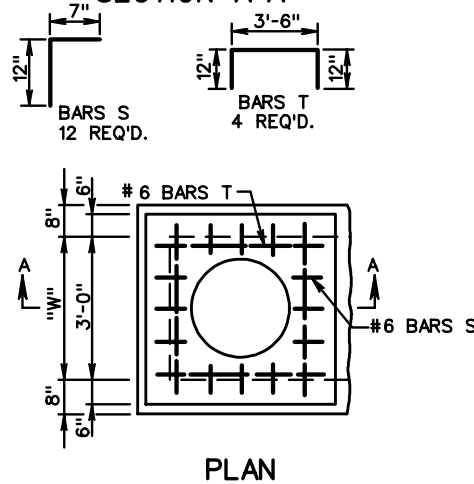

TYPE C

TO BE USED WHEN DISTANCE BETWEEN GRADE AND INVERT OF PIPE IS PIPE DIAMETER PLUS 2'-4" TO 3'-2" (SEE NOTE 3).

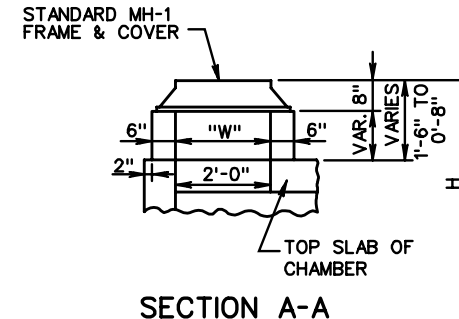

SECTION A-A

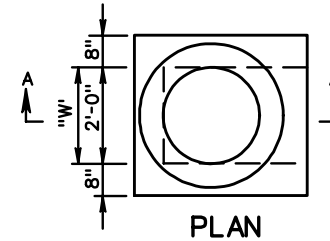

NOTES:

1. PRECAST UNITS IN ACCORDANCE WITH STANDARD MH-2 MAY BE SUBSTITUTED FOR TYPE A TOWER SHOWN. IF SUBSTITUTED, PAYMENT WILL BE MADE AT THE CONTRACT UNIT PRICE, FOR CONCRETE AND STEEL BASED ON THE THEORETICAL QUANTITIES THAT WOULD HAVE BEEN REQUIRED TO BUILD THE TYPE A TOWER.
2. SEE STANDARD SL-1 FOR APPLICABILITY OF SAFETY SLABS.
3. INCREASE INDICATED DIMENSION BY ONE FOOT FOR USE WITH 72" DIAMETER PIPE.
4. CHAMBER AND TOWER QUANTITIES FOR CONCRETE AND REINFORCING STEEL MUST BE ADDED TO OBTAIN TOTALS.

QUANTITIES FOR TOWER **

	TYPE A	TYPE B	TYPE C
CONCRETE	0.643 C.Y.	0.325 C.Y.	—
INCREMENT PER FOOT	0.262 TO 10' DEPTH 0.362 OVER 10'	0.259	0.145
REINFORCING STEEL	—	62 LBS.	—

** QUANTITIES SHOWN ARE FOR MINIMUM TOWERS OF EACH TYPE. FOR TOWERS ABOVE MINIMUM HEIGHT INCREMENTS SHOWN PER FOOT MUST BE ADDED.



ROAD AND BRIDGE STANDARDS

SHEET 3 OF 4

REVISION DATE

106.12

JUNCTION BOX TOWER DETAILS FOR 48" - 72" PIPE CULVERTS MAXIMUM DEPTH (H) = 20'

VIRGINIA DEPARTMENT OF TRANSPORTATION

SPECIFICATION REFERENCE

105
233
302

DISPLACEMENT QUANTITIES FOR PIPE OPENINGS

(TO BE USED WITH ST'D JB-I JUNCTION BOX)

PIPE SIZE	PIPE CLASS	CONCRETE				REINF. STEEL Lbs.
		0°	15°	30°	45°	
		Cu. Yards	Cu. Yards	Cu. Yards	Cu. Yards	
12"	III, IV, V	.035	.036	.040	.050	17.67
12"	CM	.019	.020	.022	.027	11.06
15"	III, IV, V	.050	.052	.058	.071	24.88
15"	CM	.030	.031	.034	.042	15.93
18"	III, IV, V	.069	.072	.080	.099	33.23
18"	CM	.043	.044	.049	.061	21.68
24"	III, IV, V	.118	.122	.137	.168	53.53
24"	CM	.076	.078	.087	.108	35.83
30"	III, IV, V	.179	.186	.208	.256	78.64
30"	CM	.118	.122	.137	.168	53.53
36"	III, IV, V	.254	.263	.294	.362	108.76
36"	CM	.170	.176	.197	.242	74.76
42"	III, IV, V	.341	.353	.395	.486	143.33
42"	CM	.231	.240	.268	.330	99.53
48"	III, IV, V	.441	.457	.511	.629	182.90
48"	CM	.302	.313	.350	.431	127.85
54"	III, IV	.554	.574	.642	.789	227.29
54"	V	.580	.600	.672	.826	237.42
54"	CM	.382	.396	.443	.545	159.70
60"	III, IV	.679	.704	.787	.965	276.49
60"	V	.708	.734	.821	1.009	287.65
60"	CM	.472	.481	.551	.673	195.09
66"	III, IV	.818	.847	.948	1.166	330.50
66"	V	.849	.880	.985	1.211	342.70
66"	CM	.571	.591	.662	.814	234.02
72"	III, IV	.969	1.004	1.123	1.382	389.34
72"	V	1.003	1.040	1.163	1.431	402.58
72"	CM	.679	.704	.787	.969	276.49

SPECIFICATION REFERENCE

105
233
302

JUNCTION BOX DISPLACEMENT QUANTITIES FOR 48" - 72" PIPE CULVERTS

VIRGINIA DEPARTMENT OF TRANSPORTATION



ROAD AND BRIDGE STANDARDS

REVISION DATE

SHEET 4 OF 4

106.13

SL-1

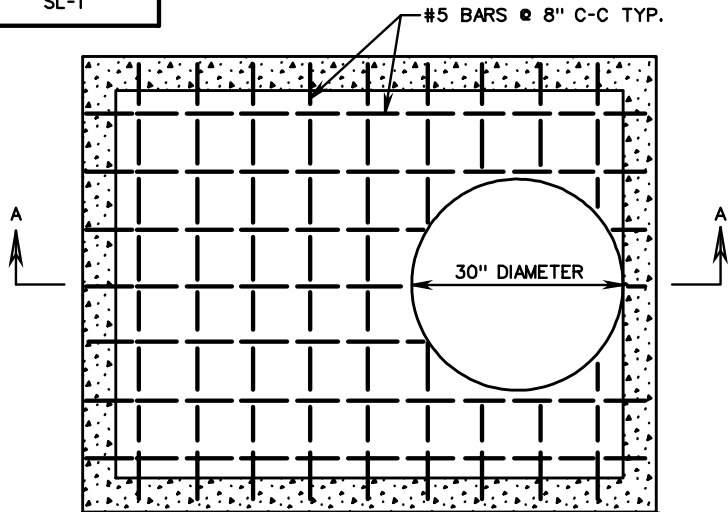

PLAN

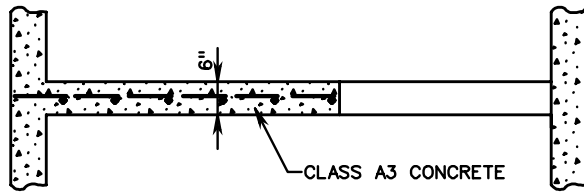

SECTION A-A

STRUCTURE SIZE AND WALL THICKNESS VARIES

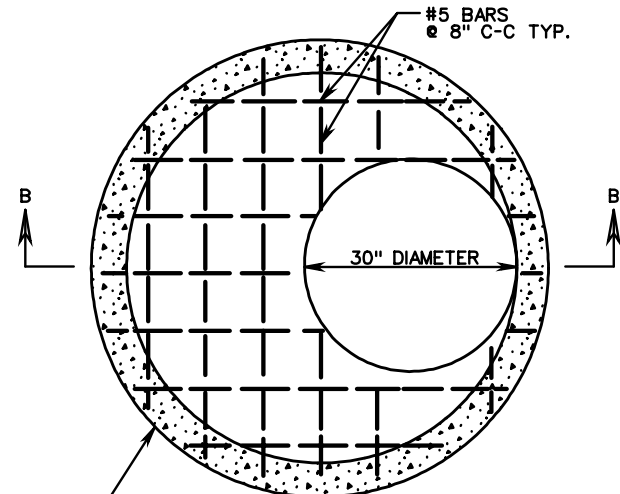

PLAN

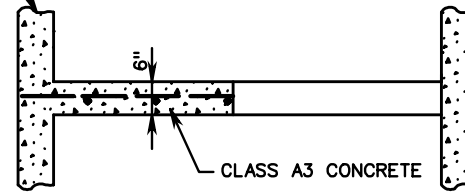

SECTION B-B

NOTES:

1. THE STANDARD SAFETY SLAB (SL-1) IS TO BE USED ONLY WHEN SPECIFIED IN THE PLANS ON THE DRAINAGE SUMMARY SHEET AND/OR THE DRAINAGE DESCRIPTION. FOR MANHOLES, JUNCTION BOXES, AND DROP INLETS WITH HEIGHTS GREATER THAN 12 FEET, THE SPACING OF ADJACENT SAFETY SLABS SHALL BE 8' TO 12' WITH NO SAFETY SLAB LOCATED WITHIN 6 FEET OF THE TOP OR BOTTOM OF THE STRUCTURE. SAFETY SLABS SHALL NOT BE LOCATED BELOW ANY INLET PIPE OF 30" DIAMETER OR GREATER.
2. THE COST OF THE SL-1 IS INCLUDED IN THE COST OF THE STRUCTURE.
3. ACCESS OPENINGS ARE TO BE STAGGERED FROM ONE SIDE OF STRUCTURE TO THE OTHER WHERE APPLICABLE. STEPS ARE TO BE STAGGERED ACCORDINGLY.
4. SAFETY SLAB MAY BE CAST-IN-PLACE OR PRECAST. CAST-IN-PLACE CONCRETE TO BE CLASS A3 (3000 PSI). PRECAST CONCRETE IS TO BE A4 (4000 PSI). REINFORCING STEEL TO BE IN ACCORDANCE WITH AASHTO M31.
5. ACCESS OPENINGS MAY BE 30" DIAMETER OR 30" SQUARE. WHEN STRUCTURE WIDTH IS LESS THAN 30" THE ACCESS OPENING SHALL BE RECTANGULAR (STRUCTURE WIDTH BY 30" LONG).

SEE CAST IN PLACE DRAWINGS FOR FURTHER DETAILS

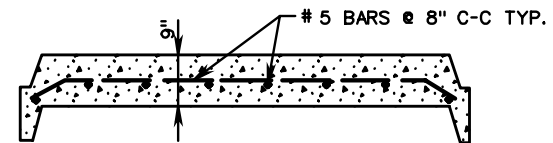

TYPICAL PRECAST UNIT



ROAD AND BRIDGE STANDARDS

SHEET 1 OF 1

REVISION DATE

106.14

TYPICAL CONCRETE SAFETY SLAB FOR DROP INLETS, MANHOLES AND JUNCTION BOXES

VIRGINIA DEPARTMENT OF TRANSPORTATION

SPECIFICATION REFERENCE

302

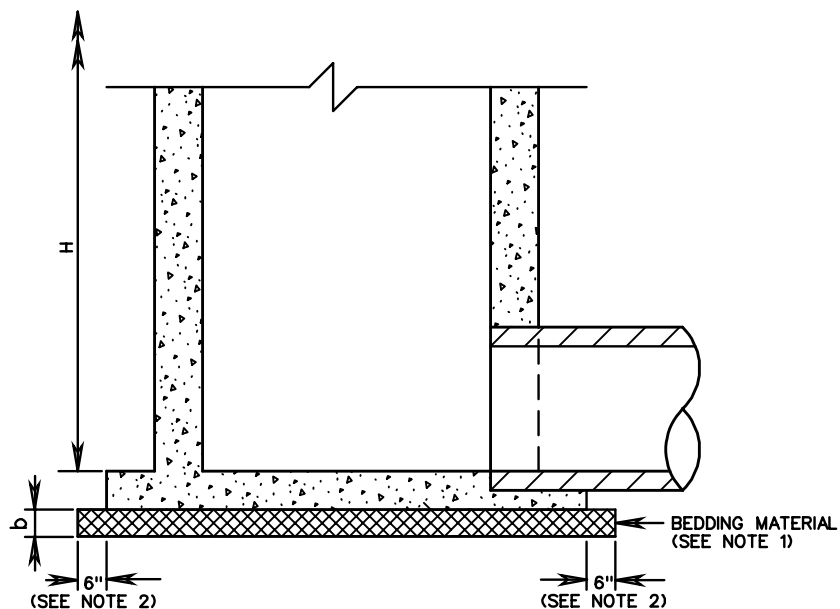

SECTIONAL ELEVATION

NOTES

1. BEDDING MATERIAL IS TO BE AGGREGATE SIZE 25 OR 26. IF FOUNDATION HAS STANDING OR RUNNING WATER PRESENT, THEN AGGREGATE NO. 57 SHALL BE USED FOR THE DEPTH SPECIFIED ON THE PLANS OR AS DIRECTED BY THE ENGINEER, CAPPED WITH 4 INCHES OF AGGREGATE NO. 25 OR 26.
2. WIDTH OF BEDDING MATERIAL SHALL EXTEND A MINIMUM OF 6" BEYOND THE BASE OF THE STRUCTURE ON ALL SIDES.
3. HEIGHT OF STRUCTURE (H) IS MEASURED FROM THE INVERT OF THE STRUCTURE TO THE TOP OF THE FRAME AND COVER OR CONCRETE DEPENDING ON STRUCTURE TYPE. SEE APPLICABLE DRAINAGE STRUCTURE STANDARD FOR DETAIL.

BEDDING THICKNESS TABLE

FOUNDATION TYPE	BEDDING THICKNESS (b)
NORMAL EARTH	4" FOR H < 10'
	6" FOR H > 10'
ROCK	1" PER FOOT OF H, MAX. 8"
SOFT & YIELDING	AS SPECIFIED ON THE PLANS OR AS DIRECTED BY THE ENGINEER

SPECIFICATION REFERENCE

302

DRAINAGE STRUCTURE BEDDING FOR DROP INLET, MANHOLE, AND JUNCTION BOX

VIRGINIA DEPARTMENT OF TRANSPORTATION

VDOT

ROAD AND BRIDGE STANDARDS

REVISION DATE

SHEET 1 OF 1

106.15

THIS PAGE INTENTIONALLY LEFT BLANK



ROAD AND BRIDGE STANDARDS

SHEET 1 OF 1

REVISION DATE

106.16

VIRGINIA DEPARTMENT OF TRANSPORTATION

SPECIFICATION
REFERENCE

GENERAL

1. METHOD "A" PIPE BEDDING SHALL BE USED FOR ALL TYPES OF PIPE CULVERTS WITHIN THE APPLICABLE HEIGHT OF COVER RANGE NOTED IN THE STANDARD PC-1 TABLES UNLESS OTHERWISE NOTED ON THE PLANS.
2. H = HEIGHT OF COVER MEASURED FROM TOP OF CULVERT TO FINISHED GRADE.
3. b = EXCAVATION DEPTH AS SHOWN ON PLANS OR TO FIRM BEARING SOIL.

CIRCULAR PIPE

1. D = OUTSIDE DIAMETER OF PIPE.
2. d = INSIDE DIAMETER OF PIPE.
3. X = WIDTH OF CLASS I BACKFILL MATERIAL BEYOND THE EXTREMITY OF THE PIPE.
 $X = 12''$ WHERE d IS LESS THAN $36''$.
 $X = 18''$ WHERE d IS $36''$ AND GREATER.
4. WHERE DIRECTED BY THE ENGINEER, BEDDING MATERIAL MAY BE ELIMINATED FOR NORMAL EARTH FOUNDATIONS UNDER ROUTINE ENTRANCE PIPE (EXCEPT PLASTIC PIPE) $30''$ AND LESS IN DIAMETER WITH HEIGHT OF COVER $15'$ OR LESS.
5. REGULAR BACKFILL MATERIAL MAY BE USED IN LIEU OF CLASS I BACKFILL MATERIAL FOR ALL FOUNDATION TYPES FOR ROUTINE ENTRANCE PIPE (EXCEPT PLASTIC PIPE) $30''$ AND LESS IN DIAMETER WITH HEIGHT OF COVER $15'$ OR LESS.
6. BEDDING MATERIAL AND CLASS I BACKFILL MATERIAL MAY BE ELIMINATED FOR SHOULDER SLOT INLET (DI-13) OUTLET PIPES INSTALLATIONS.

ELLIPTICAL PIPE

1. S_1 = OUTSIDE SPAN DIMENSION OF PIPE.
2. S_2 = INSIDE SPAN DIMENSION OF PIPE.
3. R = OUTSIDE RISE DIMENSION OF PIPE.
4. X = WIDTH OF CLASS I BACKFILL MATERIAL BEYOND THE EXTREMITY OF THE PIPE.
 $X = 12''$ WHERE S_2 IS LESS THAN $36''$.
 $X = 18''$ WHERE S_2 IS $36''$ AND GREATER
5. WHERE DIRECTED BY THE ENGINEER, BEDDING MATERIAL MAY BE ELIMINATED FOR NORMAL EARTH FOUNDATIONS UNDER ROUTINE ENTRANCE PIPE WHERE S_2 IS $38''$ OR LESS AND HEIGHT OF COVER $15'$ OR LESS.
6. REGULAR BACKFILL MATERIAL MAY BE USED IN LIEU OF CLASS I BACKFILL MATERIAL FOR ALL FOUNDATION TYPES FOR ROUTINE ENTRANCE PIPE WHERE S_2 IS $38''$ OR LESS AND HEIGHT OF COVER $15'$ OR LESS.

PIPE ARCH

1. S = SPAN DIMENSION OF PIPE.
2. R = RISE DIMENSION OF PIPE.
3. B = SEE PC-1 TABLE FOR APPLICABLE PIPE MATERIAL
4. x = WIDTH OF CLASS I BACKFILL MATERIAL BEYOND THE EXTREMITY OF THE PIPE.
 $x = 12''$ WHERE S_2 IS LESS THAN $36''$.
 $x = 18''$ WHERE S_2 IS $36''$ AND GREATER
5. WHERE DIRECTED BY THE ENGINEER, BEDDING MATERIAL MAY BE ELIMINATED FOR NORMAL EARTH FOUNDATIONS UNDER ROUTINE ENTRANCE PIPE WHERE S_2 IS $35''$ OR LESS AND HEIGHT OF COVER $15'$ OR LESS.
6. REGULAR BACKFILL MATERIAL MAY BE USED IN LIEU OF CLASS I BACKFILL MATERIAL FOR ALL FOUNDATION TYPES FOR ROUTINE ENTRANCE PIPE WHERE S IS $35''$ OR LESS AND HEIGHT OF COVER $15'$ OR LESS.

SPECIFICATION
REFERENCE302
303**INSTALLATION OF PIPE CULVERTS & STORM SEWERS
GENERAL NOTES**

VIRGINIA DEPARTMENT OF TRANSPORTATION

VDOT

ROAD AND BRIDGE STANDARDS

REVISION DATE

SHEET 1 OF 1

107.00

NO PROJECTION OF PIPE ABOVE GROUND LINE

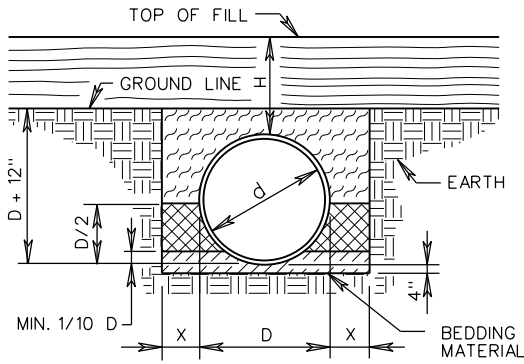

NORMAL EARTH FOUNDATION

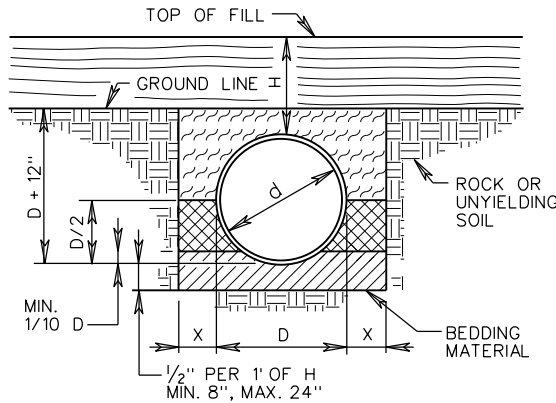

ROCK FOUNDATION

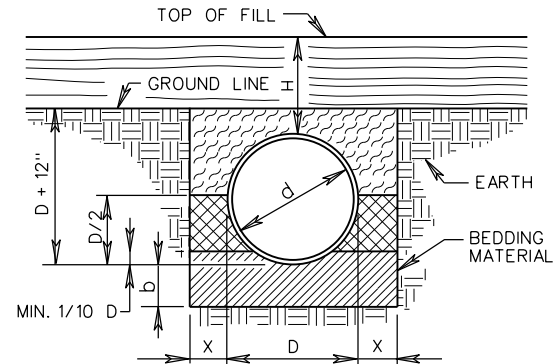

FOUNDATION SOFT, YIELDING, OR OTHERWISE UNSUITABLE MATERIAL

PIPE PROJECTION ABOVE GROUND LINE

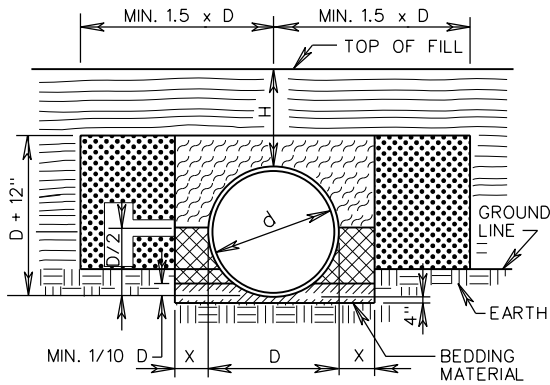

NORMAL EARTH FOUNDATION

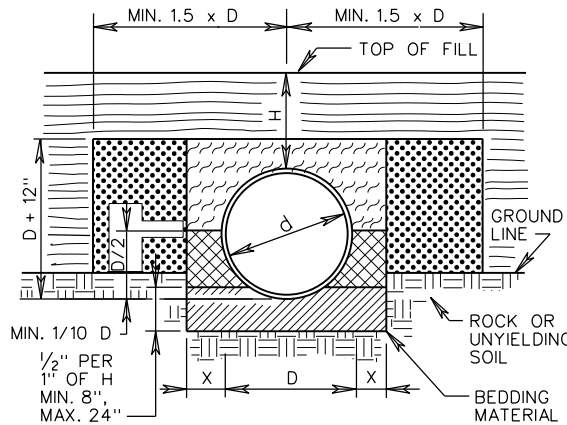

ROCK FOUNDATION

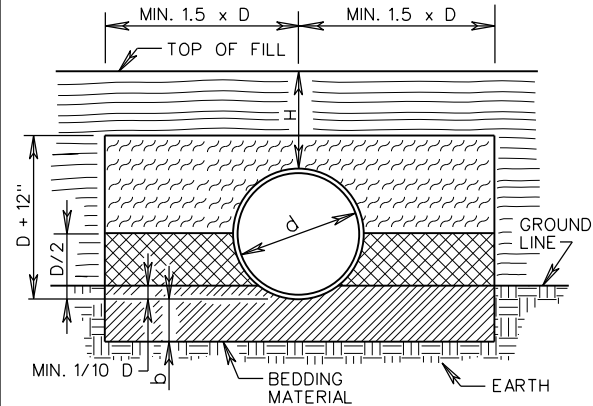

FOUNDATION SOFT, YIELDING, OR OTHERWISE UNSUITABLE MATERIAL

 BEDDING MATERIAL IN ACCORDANCE WITH SECTION 302 OF THE ROAD AND BRIDGE SPECIFICATIONS.

 CLASS I BACKFILL MATERIAL IN ACCORDANCE WITH SECTION 302 OF THE ROAD AND BRIDGE SPECIFICATIONS.

 FOR PLASTIC PIPE CLASS I BACKFILL MATERIAL IN ACCORDANCE WITH SECTION 302 OF THE ROAD AND BRIDGE SPECIFICATIONS.

 FOR ALL OTHER PIPE REGULAR BACKFILL MATERIAL IN ACCORDANCE WITH SECTION 302 OF THE ROAD AND BRIDGE SPECIFICATIONS.

 EMBANKMENT

 REGULAR BACKFILL MATERIAL IN ACCORDANCE WITH SECTION 302 OF THE ROAD AND BRIDGE SPECIFICATIONS.

NOTES:

FOR GENERAL NOTES ON PIPE BEDDING, SEE INSTALLATION OF PIPE CULVERTS AND STORM SEWERS GENERAL NOTES ON SHEET 107.00.

CRUSHED GLASS CONFORMING TO THE SIZE REQUIREMENTS FOR CRUSHER RUN AGGREGATE SIZE 25 AND 26 MAY BE USED IN PLACE OF CLASS I BACKFILL.



ROAD AND BRIDGE STANDARDS

SHEET 1 OF 4

REVISION DATE

107.01

07/12

INSTALL. OF PIPE CULVERTS AND STORM SEWERS
CIRC. PIPE BEDDING AND BACKFILL - METHOD "A"

VIRGINIA DEPARTMENT OF TRANSPORTATION

SPECIFICATION REFERENCE

302
303



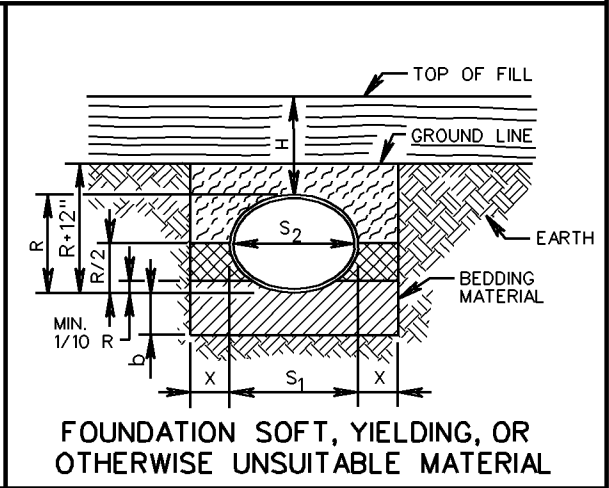
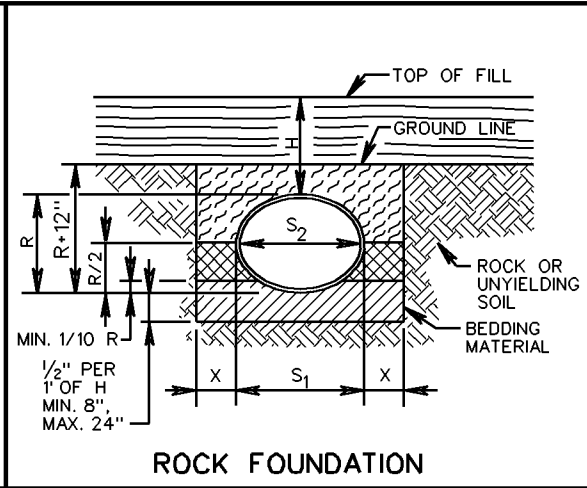
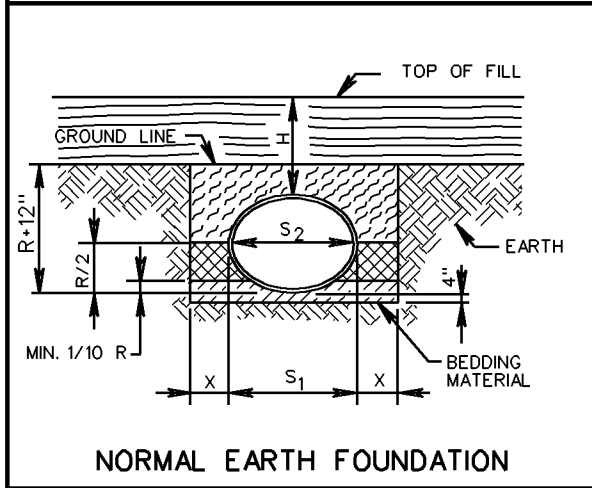

NO PROJECTION OF PIPE ABOVE GROUND LINE

PB-1

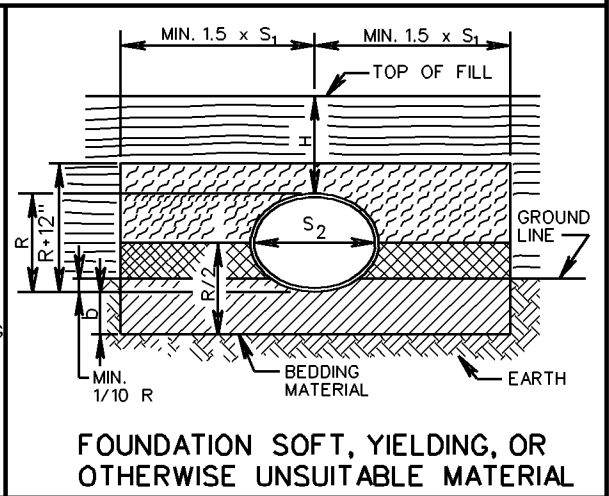
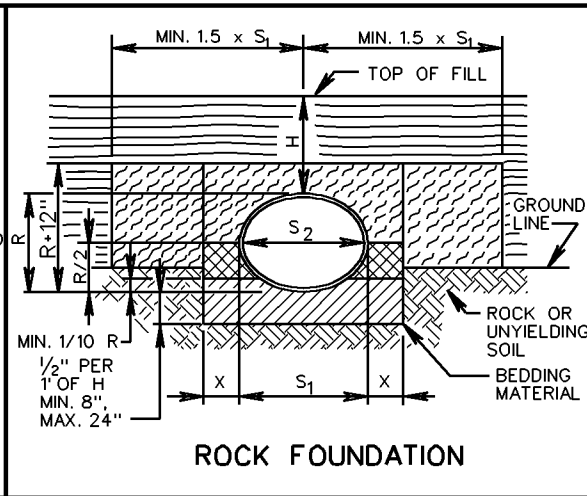
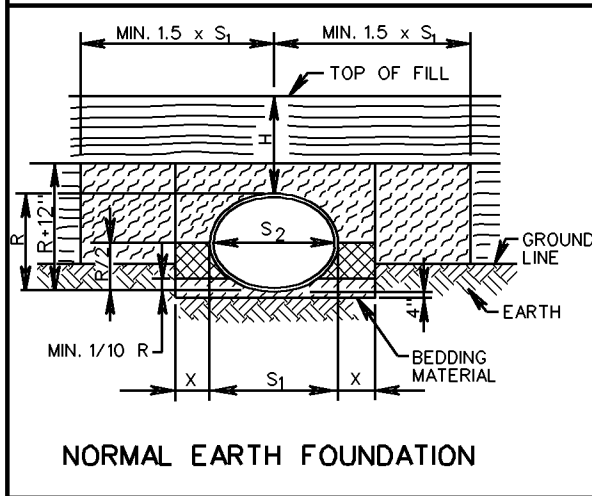

PIPE PROJECTION ABOVE GROUND LINE



-  BEDDING MATERIAL IN ACCORDANCE WITH SECTION 302 OF THE ROAD AND BRIDGE SPECIFICATIONS.
-  CLASS I BACKFILL MATERIAL IN ACCORDANCE WITH SECTION 302 OF THE ROAD AND BRIDGE SPECIFICATIONS.
-  REGULAR BACKFILL MATERIAL IN ACCORDANCE WITH SECTION 302 OF THE ROAD AND BRIDGE SPECIFICATIONS.
-  EMBANKMENT

NOTES:

FOR GENERAL NOTES ON PIPE BEDDING, SEE INSTALLATION OF PIPE CULVERTS AND STORM SEWERS GENERAL NOTES ON SHEET 107.00.
 CRUSHED GLASS CONFORMING TO THE SIZE REQUIREMENTS FOR CRUSHER RUN AGGREGATE SIZE 25 AND 26 MAY BE USED IN PLACE OF CLASS I BACKFILL.

SPECIFICATION REFERENCE
302 303

**INSTALL. OF PIPE CULVERTS AND STORM SEWERS
 ELLIP. PIPE BEDDING AND BACKFILL - METHOD "A"**

VIRGINIA DEPARTMENT OF TRANSPORTATION



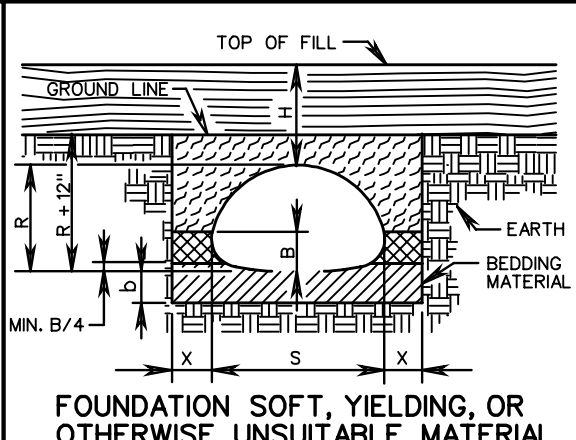
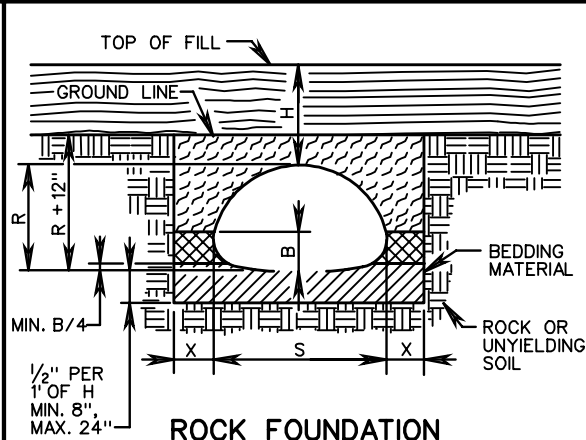
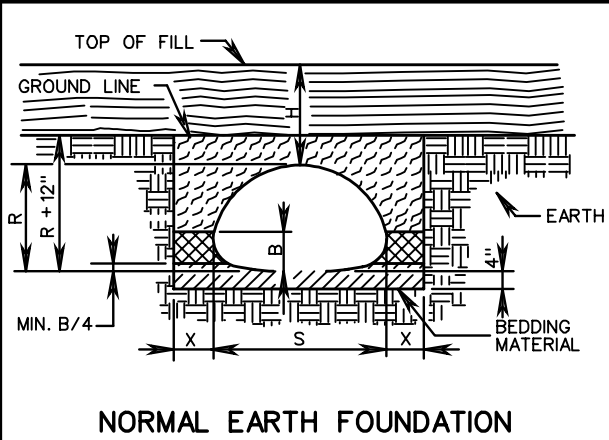

VDOT	
ROAD AND BRIDGE STANDARDS	
REVISION DATE	SHEET 2 OF 4
10/09	107.02

NO PROJECTION OF PIPE ARCH ABOVE GROUND LINE

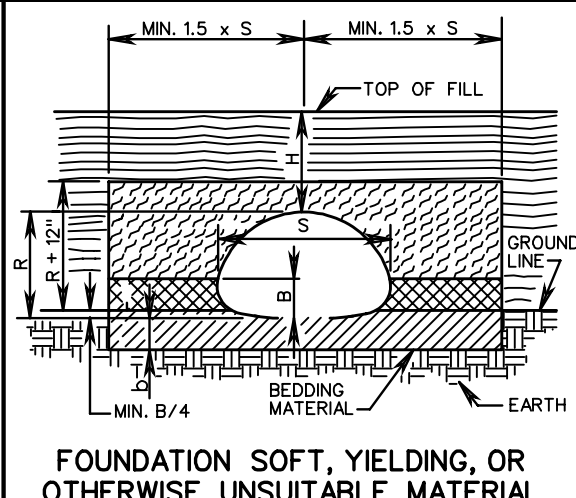
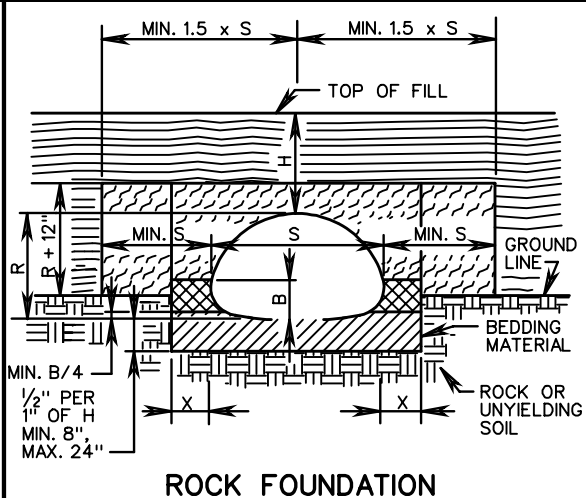
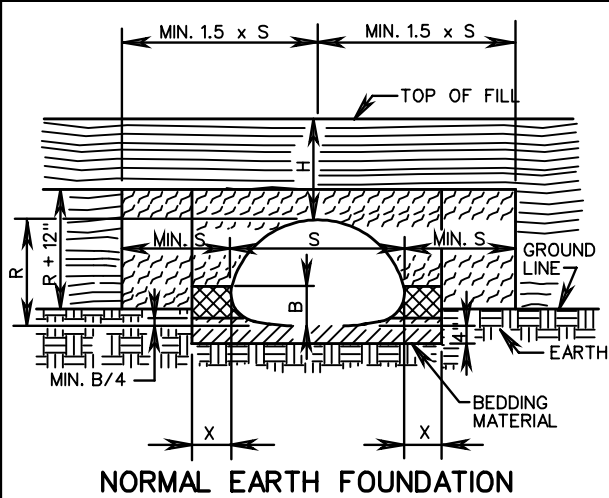

PIPE ARCH PROJECTION ABOVE GROUND LINE



-  BEDDING MATERIAL IN ACCORDANCE WITH SECTION 302 OF THE ROAD AND BRIDGE SPECIFICATIONS.
-  CLASS I BACKFILL MATERIAL IN ACCORDANCE WITH SECTION 302 OF THE ROAD AND BRIDGE SPECIFICATIONS.
-  REGULAR BACKFILL MATERIAL IN ACCORDANCE WITH SECTION 302 OF THE ROAD AND BRIDGE SPECIFICATIONS.
-  EMBANKMENT

NOTE:

FOR GENERAL NOTES ON PIPE BEDDING, SEE INSTALLATION OF PIPE CULVERTS AND STORM SEWERS GENERAL NOTES ON SHEET 107.00.

CRUSHED GLASS CONFORMING TO THE SIZE REQUIREMENTS FOR CRUSHER RUN AGGREGATE SIZE 25 AND 26 MAY BE USED IN PLACE OF CLASS I BACKFILL.



ROAD AND BRIDGE STANDARDS

SHEET 3 OF 4

REVISION DATE

107.03

INSTALLATION OF PIPE CULVERTS AND STORM SEWERS PIPE ARCH BEDDING AND BACKFILL

VIRGINIA DEPARTMENT OF TRANSPORTATION

SPECIFICATION REFERENCE

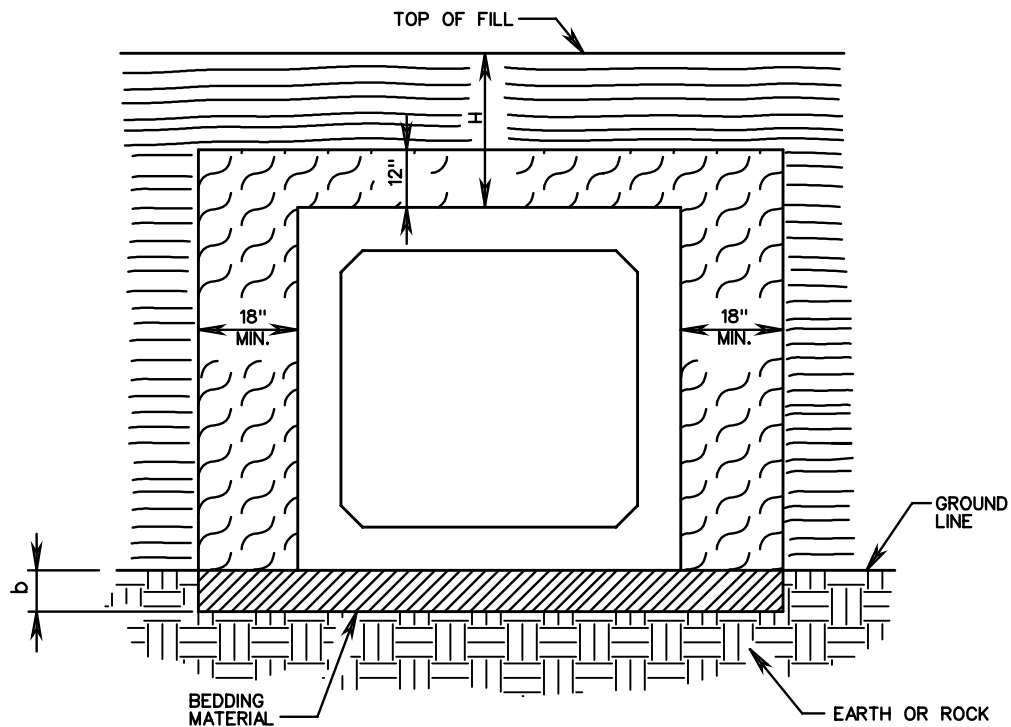

302
303



H - HEIGHT OF COVER MEASURED FROM TOP OF CULVERT TO FINISHED GRADE.

FOR NORMAL EARTH FOUNDATION:
FOR PRECAST AND CAST IN PLACE BOX CULVERT b - 6"

FOR ROCK FOUNDATION:
FOR PRECAST BOX CULVERT b = 1/4" PER 12" OF
H - 8" MIN., 24" MAX.
FOR CAST IN PLACE BOX CULVERT b-DEPTH AS SHOWN
ON PLANS OR WHERE NO BEDDING IS SPECIFIED BOTTOM
SLAB TO BE KEYED INTO EXISTING ROCK FOUNDATION.
FOR SOFT, YIELDING OR OTHERWISE UNSUITABLE FOUNDATION:
FOR PRECAST AND CAST IN PLACE BOX CULVERT
b - DEPTH AS SHOWN ON PLANS OR TO FIRM BEARING SOIL.

-  BEDDING MATERIAL IN ACCORDANCE WITH SECTION 302 OF THE ROAD AND BRIDGE SPECIFICATIONS.
-  REGULAR BACKFILL MATERIAL IN ACCORDANCE WITH SECTION 302 OF THE ROAD AND BRIDGE SPECIFICATIONS.
-  EMBANKMENT

SPECIFICATION
REFERENCE

302
303

INSTALLATION OF BOX CULVERT BEDDING AND BACKFILL - METHOD "A"

VIRGINIA DEPARTMENT OF TRANSPORTATION

VDOT

ROAD AND BRIDGE STANDARDS

REVISION DATE

SHEET 4 OF 4

107.04

DIAMETER INCHES	AREA SQ. FT.	MAXIMUM HEIGHT OF COVER IN FEET				DIAMETER INCHES
		NONREINFORCED CONCRETE (STRENGTH) (SEE NOTE 4)	REINFORCED CONCRETE CLASS			
			III	IV	V	
12	0.8	14' (1800)	14'	19'	29'	12
15	1.2	14' (2125)	14'	19'	29'	15
18	1.8	14' (2400)	14'	20'	29'	18
21	2.4	13' (2700)	14'	20'	29'	21
24	3.1	13' (3000)	14'	20'	29'	24
27	4.0		14'	20'	29'	27
30	4.9		14'	20'	29'	30
33	5.9		14'	20'	29'	33
36	7.1		14'	20'	30'	36
42	9.6		14'	21'	30'	42
48	12.6		14'	21'	30'	48
54	15.9		14'	21'	30'	54
60	19.6		14'	21'	30'	60
66	23.8		14'	21'	30'	66
72	28.3		14'	21'	30'	72
78	33.2		14'	21'	30'	78
84	38.5		14'	21'	30'	84
90	44.4		14'	21'	30'	90
96	50.3		14'	21'	30'	96
102	56.7		14'	21'	30'	102
108	63.6		14'	21'	30'	108

NOTES:

- COVER HEIGHTS INDICATED IN TABLES ARE FOR FINISHED CONSTRUCTION. THE COVER HEIGHTS WERE RETAINED TO MATCH FORMER COVER HEIGHTS BASED ON ALLOWABLE STRESS DESIGN. COVER HEIGHTS WERE NOT RE-CALCULATED USING LRFD.
- TO PROTECT PIPE DURING CONSTRUCTION, MINIMUM HEIGHTS OF COVER PRIOR TO ALLOWING CONSTRUCTION TRAFFIC TO CROSS INSTALLATION ARE TO BE 1/2 DIAMETER OR 3'0", WHICHEVER IS GREATER. THE COVER SHALL EXTEND THE FULL LENGTH OF THE PIPE. THE APPROACH FILL RAMP IS TO EXTEND A MINIMUM OF 10(DIAMETER + 36") ON EACH SIDE OF THE PIPE, OR TO THE INTERSECTION WITH A CUT.
- STANDARD MINIMUM FINISHED HEIGHT OF COVER FOR ALL PIPES, EXCEPT THOSE UNDER ENTRANCES, SHALL BE 2.0' OR 1/2 DIAMETER, WHICHEVER IS GREATER. IN CASES IN WHICH THESE COVER HEIGHTS CANNOT BE ACHIEVED, AN ABSOLUTE MINIMUM FINISHED COVER HEIGHT OF 1.0' WILL BE ALLOWED ONLY IF ALL POSSIBLE MEANS TO OBTAIN THE STANDARD VALUE HAVE BEEN EXHAUSTED. THE MINIMUM FINISHED HEIGHT OF COVER FOR PIPES UNDER ENTRANCES IS 9".
- CRUSHING STRENGTH (POUNDS PER LINEAR FOOT ULTIMATE STRENGTH) PER ASTM C76:
2000 LBS FOR CLASS III PIPE
3000 LBS FOR CLASS IV PIPE
3750 LBS FOR CLASS V PIPE
- FOR HEIGHT OF COVER GREATER THAN THAT SHOWN FOR CLASS V, A SPECIAL DESIGN CONCRETE PIPE IS REQUIRED.
- NONREINFORCED PIPE TO BE USED ONLY UNDER ENTRANCES AND LOWER FUNCTIONAL CLASSIFICATION (LFC) ROADWAYS (SEE SHEET 17 OF 18).
- SEE STANDARD PB-1 FOR PIPE BEDDING AND BACKFILL REQUIREMENTS.
- PIPE WITH LESS THAN THE STANDARD MINIMUM COVER IS TO BE MINIMUM CLASS III REINFORCED.



ROAD AND BRIDGE STANDARDS

SHEET 1 OF 18

REVISION DATE

107.05

11/15

A COPY OF THE ORIGINAL SEALED AND SIGNED DRAWING IS ON FILE IN THE CENTRAL OFFICE.

CONCRETE PIPE HEIGHT OF COVER TABLE FOR HL-93 LIVE LOAD

VIRGINIA DEPARTMENT OF TRANSPORTATION

SPECIFICATION
REFERENCE

302
232

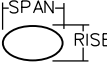
HORIZONTAL INSTALLATION 			
EQUIVALENT ROUND SIZE INCHES	SPAN X RISE INCHES	MAX. HEIGHT OF COVER IN FEET	
		CLASS	
		HE - III	HE - IV
18	23 x 14	13'	21'
24	30 x 19	13'	21'
27	34 x 22	13'	21'
30	38 x 24	13'	21'
33	42 x 27	13'	21'
36	45 x 29	13'	21'
39	49 x 32	13'	21'
42	53 x 34	13'	21'
48	60 x 38	13'	21'
54	68 x 43	13'	21'
60	76 x 48	13'	21'
66	83 x 53	13'	21'
72	91 x 58	13'	21'
78	98 x 63	13'	21'
84	106 x 68	13'	21'

VERTICAL INSTALLATION 			
SPAN X RISE INCHES	MAX. HEIGHT OF COVER IN FEET		
	CLASS		
	VE - III	VE - IV	VE - V
29 x 45	13	21	29
32 x 49	13	21	29
34 x 53	13	21	29
38 x 60	13	21	29
43 x 68	13	21	29
48 x 76	13	21	29
53 x 83	13	21	29
58 x 91	13	21	29
63 x 98	13	21	29
68 x 106	13	21	29

NOTES:

- COVER HEIGHTS INDICATED IN TABLES ARE FOR FINISHED CONSTRUCTION. THE COVER HEIGHTS WERE RETAINED TO MATCH FORMER COVER HEIGHTS BASED ON ALLOWABLE STRESS DESIGN. COVER HEIGHTS WERE NOT RE-CALCULATED USING LRFD.
- TO PROTECT PIPE DURING CONSTRUCTION, MINIMUM HEIGHTS OF COVER PRIOR TO ALLOWING CONSTRUCTION TRAFFIC TO CROSS INSTALLATION ARE TO BE 1/2 SPAN OR 3', WHICHEVER IS GREATER. THE COVER SHALL EXTEND THE FULL LENGTH OF THE PIPE. THE APPROACH FILL RAMP IS TO EXTEND A MINIMUM OF 10(SPAN + 36") ON EACH SIDE OF THE PIPE OR TO THE INTERSECTION WITH A CUT.
- STANDARD MINIMUM FINISHED HEIGHT OF COVER FOR ALL PIPES SHALL BE 2.0' OR 1/2 SPAN, WHICHEVER IS GREATER. IN CASES IN WHICH THESE COVER HEIGHTS CANNOT BE ACHIEVED, AN ABSOLUTE MINIMUM FINISHED COVER HEIGHT OF 1.0' WILL BE ALLOWED ONLY IF ALL POSSIBLE MEANS TO OBTAIN THE STANDARD VALUE HAVE BEEN EXHAUSTED. MINIMUM FINISHED HEIGHT OF COVER FOR PIPE UNDER ENTRANCES IS 9".
- SEE STANDARD PB-1 FOR PIPE BEDDING AND BACKFILL REQUIREMENTS.

SPECIFICATION REFERENCE	A COPY OF THE ORIGINAL SEALED AND SIGNED DRAWING IS ON FILE IN THE CENTRAL OFFICE. REINFORCED ELLIPTICAL CONCRETE PIPE HEIGHT OF COVER TABLES FOR HL-93 LIVE LOAD VIRGINIA DEPARTMENT OF TRANSPORTATION	 ROAD AND BRIDGE STANDARDS	

**CORRUGATED STEEL PIPE
2 2/3" x 1/2" CORRUGATIONS**

PIPE DIAMETER INCHES	AREA SQ. FT.	MAXIMUM HEIGHT OF COVER IN FEET					MINIMUM SHEET THICKNESS FOR ENTRANCE PIPES WITH LESS THAN 1 FT COVER INCHES (GAUGE)
		SHEET THICKNESS IN INCHES (GAUGE)					
		0.064 (16)	0.079 (14)	0.109 (12)	0.138 (10)	0.168 (8)	
12	0.79	233	291				0.064 (16)
15	1.23	186	233				0.064 (16)
18	1.77	155	194	272			0.064 (16)
21	2.40	132	166	233			0.064 (16)
24	3.14	116	145	203			0.064 (16)
27	3.98	102	128	180			0.064 (16)
30	4.91	92	115	162			0.064 (16)
33	5.94	83	105	147	190		0.064 (16)
36	7.1	76	96	135	174		0.064 (16)
42	9.6	65	81	115	149	182	0.064 (16)
48	12.6	56	71	100	130	159	0.064 (16)
54	16.0		63	89	115	141	0.079 (14)
60	19.6			79	103	126	0.109 (12)
66	23.8				93	114	0.138 (10)
72	28.3				85	105	0.138 (10)
78	33.2					96	0.168 (8)
84	38.5					89	0.168 (8)

NOTES:

- COVER HEIGHTS INDICATED IN TABLES ARE FOR FINISHED CONSTRUCTION, USING AASHTO LRFD BRIDGE DESIGN SPECIFICATIONS AND ASSUMING 25% METAL LOSS AT END OF DESIGN LIFE.
- TO PROTECT PIPE DURING CONSTRUCTION, MINIMUM HEIGHT OF COVER TO BE IN ACCORDANCE WITH TABLE A PRIOR TO ALLOWING CONSTRUCTION TRAFFIC TO CROSS INSTALLATION. THE COVER SHALL EXTEND THE FULL LENGTH OF THE PIPE. THE APPROACH FILL RAMP IS TO EXTEND A MINIMUM OF 15 DIAMETERS ON EACH SIDE OF THE PIPE OR THE INTERSECTION WITH A CUT.
- STANDARD MINIMUM FINISHED HEIGHT OF COVER FOR ALL PIPES, EXCEPT UNDER ENTRANCES, SHALL BE 2.0' OR 1/2 DIAMETER, WHICHEVER IS GREATER. IN CASES IN WHICH THESE COVER HEIGHTS CANNOT BE ACHIEVED, AN ABSOLUTE MINIMUM FINISHED COVER HEIGHT OF 1.0' OR 1/8 DIAMETER, WHICHEVER IS GREATER, WILL BE ALLOWED ONLY IF ALL POSSIBLE MEANS TO OBTAIN THE STANDARD VALUE HAVE BEEN EXHAUSTED. THE MINIMUM FINISHED HEIGHT OF COVER FOR PIPES UNDER ENTRANCES IS 9" FOR PIPE DIAMETERS LESS THAN OR EQUAL TO 24" AND 12" OR 1/8 DIAMETER, WHICHEVER IS GREATER, FOR PIPE DIAMETERS GREATER THAN 24". WHERE A POLYMER COATED PIPE WILL BE USED AND THE SURFACE OVER THE TOP OF THE PIPE WILL BE ASPHALT, CLASS I BACKFILL MATERIAL IS TO BE PLACED UP TO A MINIMUM OF 6" ABOVE THE TOP OF THE PIPE.
- SEE STANDARD PB-1 FOR PIPE BEDDING AND BACKFILL REQUIREMENTS.

TABLE A

PIPE DIAMETER	MINIMUM COVER HEIGHT DURING CONSTRUCTION (SEE NOTE 2)
12" TO 33"	18"
36" AND ABOVE	1/2 DIAMETER

CONCRETE- LINED CORRUGATED STEEL PIPE

MAXIMUM HEIGHT OF COVER TO BE IN ACCORDANCE WITH THE TABLES BUT SHALL NOT EXCEED 30".

**CORRUGATED STEEL PIPE
3" x 1" CORRUGATIONS**

PIPE DIAMETER INCHES	AREA SQ. FT.	MAXIMUM HEIGHT OF COVER IN FEET				
		SHEET THICKNESS IN INCHES (GAUGE)				
		0.064 (16)	0.079 (14)	0.109 (12)	0.138 (10)	0.168 (8)
36	7.1	88	110	155	200	246
42	9.6	75	94	133	171	210
48	12.6	65	82	116	149	183
54	16.0	57	72	102	132	163
60	19.6	51	65	92	119	146
66	23.8	46	58	83	108	132
72	28.3	42	53	76	98	121
78	33.2	38	49	69	90	111
84	38.5	35	45	64	83	103
90	44.2	32	41	59	77	96
96	50.3		38	55	72	89
102	56.7		36	52	68	84
108	63.6			49	64	80
114	70.9			45	60	74
120	78.5			43	56	70
132	95.0				51	63
144	113.0					57

**CORRUGATED STEEL PIPE
5" x 1" CORRUGATIONS**

PIPE DIAMETER INCHES	AREA SQ. FT.	MAXIMUM HEIGHT OF COVER IN FEET				
		SHEET THICKNESS IN INCHES (GAUGE)				
		0.064 (16)	0.079 (14)	0.109 (12)	0.138 (10)	0.168 (8)
36	7.1	78	98	138	178	218
42	9.6	66	84	118	152	187
48	12.6	58	73	103	133	163
54	16.0	51	64	91	118	144
60	19.6	45	57	81	105	130
66	23.8	41	52	74	95	117
72	28.3	37	47	67	87	107
78	33.2	34	43	61	80	99
84	38.5	31	39	57	74	91
90	44.2	28	36	53	69	85
96	50.3		34	49	64	79
102	56.7		31	46	60	74
108	63.6			43	56	69
114	70.9			40	53	65
120	78.5			38	50	62
132	95.0				44	55
144	113.0					50

A COPY OF THE ORIGINAL SEALED AND SIGNED DRAWING IS ON FILE IN THE CENTRAL OFFICE.

**CORRUGATED STEEL PIPE
HEIGHT OF COVER TABLES FOR HL-93 LIVE LOAD**

VIRGINIA DEPARTMENT OF TRANSPORTATION

SPECIFICATION REFERENCE

302
232



ROAD AND BRIDGE STANDARDS

SHEET 3 OF 18

REVISION DATE

107.07

11/15

**CORRUGATED ALUMINUM ALLOY PIPE-
2 2/3" x 1/2" CORRUGATIONS**

PIPE DIAMETER INCHES	AREA SQ. FT.	MAXIMUM HEIGHT OF COVER IN FEET					MINIMUM SHEET THICKNESS FOR ENTRANCE PIPES WITH LESS THAN 1 FT. COVER (GAUGE)
		SHEET THICKNESS IN INCHES (GAUGE)					
		0.060 (16)	0.075 (14)	0.105 (12)	0.135 (10)	0.164 (8)	
12	0.8	141	176	247	318	389	16
15	1.2	112	141	197	254	311	16
18	1.8	93	117	164	212	259	16
21	2.4	80	100	140	181	221	16
24	3.1	69	87	123	158	193	16
27	4.0		77	109	140	172	14
30	4.9		69	98	126	154	14
33	5.9		63	88	114	140	14
36	7.1		57	81	105	128	14
42	9.6			69	89	109	12
48	12.6			60	78	95	12
54	15.9			53	69	84	12
60	19.6				61	75	10
66	23.8					68	8
72	28.3					62	8

CORRUGATED ALUMINUM ALLOY PIPE- 3" x 1" CORRUGATIONS

PIPE DIAMETER INCHES	AREA SQ. FT.	MAXIMUM HEIGHT OF COVER IN FEET				
		SHEET THICKNESS IN INCHES (GAUGE)				
		0.060 (16)	0.075 (14)	0.105 (12)	0.135 (10)	0.164 (8)
36	7.1	52	66	93	126	148
42	9.6	44	56	80	107	127
48	12.6	38	49	69	93	110
54	16.0	34	43	61	83	98
60	19.6	30	38	54	74	87
66	23.8	26	34	49	67	79
72	28.3	24	31	45	61	72
78	33.2		28	41	56	66
84	38.5			37	51	61
90	44.2			34	47	57
96	50.3			32	44	53
102	56.7				41	49
108	63.6				38	46
114	70.9					43
120	78.5					41

NOTES:

- COVER HEIGHTS INDICATED IN TABLES ARE FOR FINISHED CONSTRUCTION, USING AASHTO LRFD BRIDGE DESIGN SPECIFICATIONS AND ASSUMING 25% METAL LOSS AT END OF DESIGN LIFE.
- TO PROTECT PIPE DURING CONSTRUCTION, MINIMUM HEIGHT OF COVER TO BE IN ACCORDANCE WITH TABLE A PRIOR TO ALLOWING CONSTRUCTION TRAFFIC TO CROSS INSTALLATION. THE COVER SHALL EXTEND THE FULL LENGTH OF THE PIPE. THE APPROACH FILL RAMP IS TO EXTEND A MINIMUM OF 20 DIAMETERS ON EACH SIDE OF THE PIPE OR THE INTERSECTION WITH A CUT.
- STANDARD MINIMUM FINISHED HEIGHT OF COVER FOR ALL PIPES, EXCEPT THOSE UNDER ENTRANCES, SHALL BE 2.0' OR 1/2 DIAMETER, WHICHEVER IS GREATER. IN CASES IN WHICH THESE COVER HEIGHTS CANNOT BE ACHIEVED, AN ABSOLUTE MINIMUM FINISHED COVER HEIGHT OF 1.0' OR 1/8 DIAMETER, WHICHEVER IS GREATER, WILL BE ALLOWED ONLY IF ALL POSSIBLE MEANS TO OBTAIN THE STANDARD VALUE HAVE BEEN EXHAUSTED. THE MINIMUM FINISHED HEIGHT OF COVER FOR PIPES UNDER ENTRANCES IS 9" FOR PIPE DIAMETERS EQUAL TO OR LESS THAN 18" AND 12" OR 1/8 DIAMETER, WHICHEVER IS GREATER, FOR PIPE DIAMETERS GREATER THAN 18".
- SEE STANDARD PB-1 FOR PIPE BEDDING AND BACKFILL REQUIREMENTS.

TABLE A

PIPE DIAMETER	MINIMUM COVER HEIGHT DURING CONSTRUCTION (SEE NOTE 2)
12" TO 27"	18"
30" AND OVER	EQUAL TO DIAMETER

SPECIFICATION REFERENCE

232
302

A COPY OF THE ORIGINAL SEALED AND SIGNED DRAWING IS ON FILE IN THE CENTRAL OFFICE.

**CORRUGATED ALUMINUM ALLOY PIPE
HEIGHT OF COVER TABLE FOR HL-93 LIVE LOAD**

VIRGINIA DEPARTMENT OF TRANSPORTATION



ROAD AND BRIDGE STANDARDS

REVISION DATE

11/15

SHEET 4 OF 18

107.08

MINIMUM SHEET THICKNESS AND DESIGN DATA

PIPE ARCH DIMENSION					MINIMUM SHEET THICKNESS REQUIRED INCHES (GAUGE)	MAXIMUM COVER HEIGHT IN FEET	
NOMINAL SIZE SPAN - RISE INCHES	EQUIVALENT PIPE DIAMETER INCHES	AREA SQ. FT.	MAXIMUM "B" INCHES (SEE NOTE 7)	Rc INCHES		MAXIMUM CORNER PRESSURE	
						4000 LBS./SQ. FT. (SEE NOTE 4)	6000 LBS./SQ. FT. (SEE NOTE 6)
2 2/3" x 1/2" CORRUGATIONS							
17 x 13	15	1.1	5 1/4"	3	0.064 (16)	11	17
21 x 15	18	1.6	6"	3	0.064 (16)	9	14
24 x 18	21	2.2	7 1/4"	3	0.064 (16)	8	12
28 x 20	24	2.8	8"	3	0.064 (16)	7	10
35 x 24	30	4.4	9 1/2"	3	0.064 (16)	5	8
42 x 29 ☉	36	6.4	10 1/2"	3 1/2	0.064 (16)	5	8
49 x 33 ☉	42	8.7	11 1/2"	4	0.079 (14)	5	8
57 x 38 ☉	48	11.4	13 1/2"	5	0.109 (12)	5	8
64 x 43 ☉	54	14.3	15"	6	0.109 (12)	6	9
71 x 47 ☉	60	17.6	16 1/2"	7	0.138 (10)	6	9
77 x 52 ☉	66	21.3	18"	8	0.168 (8)	6	10
83 x 57 ☉	72	25.3	20"	9	0.168 (8)	7	10
3" x 1" AND 5" x 1" CORRUGATIONS							
40 x 31 ☉	36	6.4	9 3/4"	5	0.109 (12)	8	12
46 x 36 ☉	42	8.7	11 1/2"	6	0.109 (12)	8	12
53 x 41 ☉	48	11.4	13"	7	0.109 (12)	8	13
60 x 46 ☉	54	14.3	14 3/4"	8	0.109 (12)	8	13
66 x 51 ☉	60	17.6	16 1/2"	9	0.109 (12)	9	13
73 x 55 ☉	66	22.0	21 1/2"	12	0.109 (12)	11	16
81 x 59 ☉	72	26.0	23"	14	0.109 (12)	11	17
87 x 63	78	31.0	24 1/2"	14	0.109 (12)	10	16
95 x 67	84	35.0	26 1/2"	16	0.109 (12)	11	16
103 x 71	90	40.0	27"	16	0.109 (12)	10	15
112 x 75	96	46.0	29"	18	0.109 (12)	10	16
117 x 79	102	52.0	30 3/4"	18	0.109 (12)	10	15
128 x 83	108	58.0	29 1/2"	18	0.138 (10)	9	14
137 x 87	114	64.0	30 3/4"	18	0.138 (10)	8	13
142 x 91	120	71.0	32 1/2"	18	0.168 (8)	8	12

☉ INDICATES PIPE ARCHES FOR WHICH DIMENSIONS FOR EITHER CORRUGATION MAY BE USED WITHIN HEIGHT OF COVER LIMITATIONS.

NOTES:

- COVER HEIGHTS INDICATED IN TABLES ARE FOR FINISHED CONSTRUCTION WHICH MATCH FORMER VDOT ALLOWABLE STRESS DESIGN TABLES. COVER HEIGHTS WERE NOT RE-CALCULATED USING LRFD
- TO PROTECT PIPE DURING CONSTRUCTION, MINIMUM HEIGHT OF COVER TO BE IN ACCORDANCE WITH TABLE A PRIOR TO ALLOWING CONSTRUCTION TRAFFIC TO CROSS INSTALLATION. THE COVER SHALL EXTEND THE FULL LENGTH OF THE PIPE ARCH. THE APPROACH FILL RAMP IS TO EXTEND A MINIMUM OF 10'(HEIGHT + 1/2 SPAN) ON EACH SIDE OF THE PIPE, OR TO THE INTERSECTION WITH A CUT.
- STANDARD MINIMUM FINISHED HEIGHT OF COVER FOR ALL PIPES SHALL BE 2'0" OR 1/2 SPAN, WHICHEVER IS GREATER. IN CASES IN WHICH THESE COVER HEIGHTS CANNOT BE ACHIEVED, AN ABSOLUTE MINIMUM FINISHED COVER HEIGHT OF 1.0' OR 1/8 SPAN, WHICHEVER IS GREATER, WILL BE ALLOWED ONLY IF ALL POSSIBLE MEANS TO OBTAIN THE STANDARD VALUE HAVE BEEN EXHAUSTED. WHERE POLYMER COATED PIPE WILL BE USED AND THE SURFACE OVER THE TOP OF THE PIPE WILL BE ASPHALT, CLASS I BACKFILL MATERIAL IS TO BE PLACED UP TO A MINIMUM OF 6" ABOVE THE TOP OF THE PIPE.
- SEE STANDARD PB-1 FOR PIPE BEDDING AND BACKFILL REQUIREMENTS.
- THE MAXIMUM HEIGHT OF COVER SHOWN IN THE TABLES IS BASED ON A SOIL MODULUS OF 700 PSI. ALL OTHER DESIGN CRITERIA ARE IN ACCORDANCE WITH THE AASHTO SPECIFICATIONS AND VDOT MODIFICATIONS FOR SOIL CORRUGATED METAL STRUCTURE INTERACTION SYSTEMS.
- WHEN DESIGN HEIGHT OF COVER REQUIRES THE USE OF THIS CATEGORY OF PIPE, FOUNDATION AND BACKFILL MUST BE APPROVED BY THE ENGINEER.
- SPAN OF PIPE ARCHES IS MEASURED "B" INCHES ABOVE THE INVERT. SEE DIAGRAM BELOW FOR ILLUSTRATION OF "B" DIMENSION.

PIPE ARCH SPAN	MINIMUM COVER HEIGHT DURING CONSTRUCTION (SEE NOTE 2)
17" TO 35"	18"
42" AND ABOVE	1/2 SPAN

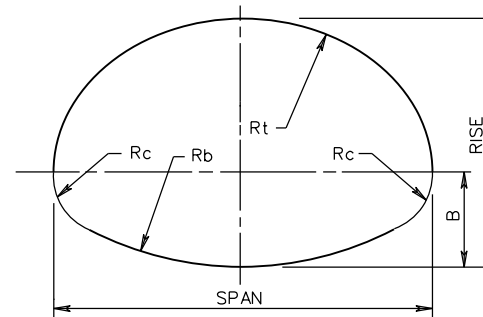

ROAD AND BRIDGE STANDARDS

A COPY OF THE ORIGINAL SEALED AND SIGNED DRAWING IS ON FILE IN THE CENTRAL OFFICE.

**CORRUGATED STEEL PIPE ARCH
HEIGHT OF COVER TABLE FOR HL-93 LIVE LOAD**

VIRGINIA DEPARTMENT OF TRANSPORTATION

SPECIFICATION REFERENCE

232
302

SHEET 5 OF 18

REVISION DATE

107.09

11/15

MINIMUM SHEET THICKNESS AND DESIGN DATA

PIPE ARCH DIMENSION				MINIMUM SHEET THICKNESS REQUIRED INCHES (GAUGE)	MAXIMUM COVER HEIGHT IN FEET	
NOMINAL SIZE SPAN-RISE INCHES	EQUIVALENT PIPE DIAMETER INCHES	AREA SQ. FT.	Rc INCHES		MAXIMUM CORNER PRESSURE	
					4000 LBS./SQ. FT. (SEE NOTE 4)	6000 LBS./SQ. FT. (SEE NOTE 6)
2 2/3" x 1/2" CORRUGATIONS						
17 x 13	15	1.1	3"	0.060 (16)	11	17
21 x 15	18	1.6	3"	0.060 (16)	9	14
24 x 18	21	2.2	3"	0.060 (16)	8	12
28 x 20	24	2.8	3"	0.075 (14)	7	10
35 x 24	30	4.4	3"	0.075 (14)	5	8
42 x 29 ⊗	36	6.4	3 1/2"	0.105 (12)	5	8
49 x 33 ⊗	42	8.7	4"	0.105 (12)	5	8
57 x 38 ⊗	48	11.4	5"	0.135 (10)	5	8
64 x 43 ⊗	54	14.3	6"	0.135 (10)	6	9
71 x 47 ⊗	60	17.6	7"	0.164 (8)	6	9
3" x 1" CORRUGATIONS						
40 x 31 ⊗	36	6.4	5"	0.060 (16)	8	12
46 x 36 ⊗	42	8.7	6"	0.060 (16)	8	12
53 x 41 ⊗	48	11.4	7"	0.060 (16)	8	13
60 x 46 ⊗	54	14.3	8"	0.075 (14)	8	13
66 x 51 ⊗	60	17.6	9"	0.075 (14)	9	13
73 x 55	66	22.0	12"	0.105 (12)	11	16
81 x 59	72	26.0	14"	0.105 (12)	11	17
87 x 63	78	31.0	14"	0.135 (10)	10	16
95 x 67	84	35.0	16"	0.135 (10)	11	16
103 x 71	90	40.0	16"	0.164 (8)	10	15
112 x 75	96	46.0	18"	0.164 (8)	10	13
117 x 79	102	52.0	18"	0.164 (8)	10	11

⊗ INDICATES PIPE ARCHES FOR WHICH DIMENSIONS FOR EITHER CORRUGATION MAY BE USED WITHIN HEIGHT OF COVER LIMITATIONS.

NOTES:

- COVER HEIGHTS INDICATED IN TABLES ARE FOR FINISHED CONSTRUCTION WHICH MATCH FORMER VDOT ALLOWABLE STRESS DESIGN TABLES. COVER HEIGHTS WERE NOT RE-CALCULATED USING LRFSD
- TO PROTECT PIPE DURING CONSTRUCTION, MINIMUM HEIGHT OF COVER TO BE IN ACCORDANCE WITH TABLE A PRIOR TO ALLOWING CONSTRUCTION TRAFFIC TO CROSS INSTALLATION. THE COVER SHALL EXTEND THE FULL LENGTH OF THE PIPE ARCH. THE APPROACH FILL RAMP IS TO EXTEND A MINIMUM OF 10(HHEIGHT + 1/2 SPAN) ON EACH SIDE OF THE STRUCTURE OR TO THE INTERSECTION WITH A CUT.
- STANDARD MINIMUM FINISHED HEIGHT OF COVER FOR ALL PIPES SHALL BE 2'0" OR 1/8 SPAN, WHICHEVER IS GREATER. IN CASES IN WHICH THESE COVER HEIGHTS CANNOT BE ACHIEVED, AN ABSOLUTE MINIMUM FINISHED COVER HEIGHT OF 1.0' OR 1/8 SPAN, WHICHEVER IS GREATER, WILL BE ALLOWED ONLY IF ALL POSSIBLE MEANS TO OBTAIN THE STANDARD VALUE HAVE BEEN EXHAUSTED.
- SEE STANDARD PB-1 FOR PIPE BEDDING AND BACKFILL REQUIREMENTS.
- THE MAXIMUM HEIGHT OF COVER SHOWN IN THE TABLES IS BASED ON A SOIL MODULUS OF 700 PSI. ALL OTHER DESIGN CRITERIA ARE IN ACCORDANCE WITH THE AASHTO SPECIFICATIONS AND VDOT MODIFICATIONS FOR SOIL CORRUGATED METAL STRUCTURE INTERACTION SYSTEMS.
- WHEN DESIGN HEIGHT OF COVER REQUIRES THE USE OF THIS CATEGORY OF PIPE BEDDING FOUNDATION AND BACKFILL MUST BE APPROVED BY THE ENGINEER.
- LAPPED LONGITUDINAL SEAMS SHALL BE STAGGERED SO AS TO ALTERNATE ON EACH SIDE OF THE CENTER OF ARCH TOP BY APPROXIMATELY 15 PERCENT OF THE PERIPHERY.
- A TOLERANCE OF PLUS, OR MINUS, 1" IS PERMISSIBLE FOR DIMENSIONS OF SPAN, RISE, AND CORNER RADIUS.

PIPE DIAMETER	MINIMUM COVER HEIGHT DURING CONSTRUCTION (SEE NOTE 2)
17" TO 35"	18"
42" AND ABOVE	1/2 SPAN

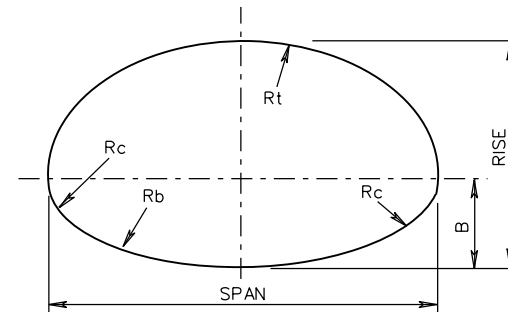

SPECIFICATION REFERENCE

232
302

A COPY OF THE ORIGINAL SEALED AND SIGNED DRAWING IS ON FILE IN THE CENTRAL OFFICE.
CORRUGATED ALUMINUM ALLOY PIPE ARCH
HEIGHT OF COVER TABLE FOR HL-93 LIVE LOAD
 VIRGINIA DEPARTMENT OF TRANSPORTATION

VDOT

ROAD AND BRIDGE STANDARDS

REVISION DATE
11/15

SHEET 6 OF 18
107.10

**STRUCTURAL PLATE STEEL PIPE-
6" x 2" CORRUGATIONS**

PIPE DIAMETER INCHES	AREA SQ. FT.	MINIMUM HEIGHT OF COVER IN FEET						
		SHEET THICKNESS IN INCHES (GAUGE)						
		0.11 (12)	0.14 (10)	0.17 (8)	0.188 (7)	0.218 (5)	0.249 (3)	0.280 (1)
60	20	91	118	145	163	191	218	246
66	24	83	107	132	148	173	198	224
72	28	75	98	120	135	158	181	205
78	33	69	90	111	124	146	167	188
84	38	64	83	103	115	135	154	175
90	44	59	77	95	107	126	144	163
96	50	55	72	89	100	117	134	152
102	57	51	67	83	94	110	126	143
108	64	48	63	78	88	104	119	134
114	71	45	60	74	83	98	112	127
120	78	43	56	70	79	92	106	120
132	95	38	50	63	71	83	96	109
144	113	34	45	57	64	76	87	99
156	133	31	41	52	58	69	80	91
168	154	28	38	47	54	63	73	83
180	177	25	34	43	49	59	68	77
192	201		31	40	45	54	63	72
204	227		29	37	42	50	58	67
216	254			34	39	47	54	62
228	284			31	36	44	51	58
240	314				34	41	48	55

NOTES:

- COVER HEIGHTS INDICATED IN TABLE ARE FOR FINISHED CONSTRUCTION, USING AASHTO LRFD BRIDGE DESIGN SPECIFICATIONS AND ASSUMING 25% METAL LOSS AT END OF DESIGN LIFE.
- TO PROTECT PIPE DURING CONSTRUCTION MINIMUM HEIGHT OF COVER PRIOR TO ALLOWING CONSTRUCTION TRAFFIC TO CROSS INSTALLATION IS TO BE 1*2 DIAMETER. THIS COVER SHALL EXTEND THE FULL LENGTH OF THE PIPE. THE APPROACH FILL RAMP IS TO EXTEND A MINIMUM OF 10(DIAMETER + 36") ON EACH SIDE OF THE PIPE OR TO THE INTERSECTION WITH A CUT.
- STANDARD MINIMUM FINISHED HEIGHT OF COVER FOR ALL PIPES SHALL BE 2.0' OR 1*2 DIAMETER, WHICHEVER IS GREATER. IN CASES IN WHICH THESE COVER HEIGHTS CANNOT BE ACHIEVED, AN ABSOLUTE MINIMUM FINISHED COVER HEIGHT OF 1.0' OR 1*8 DIAMETER WILL BE ALLOWED ONLY IF ALL POSSIBLE MEANS TO OBTAIN THE STANDARD VALUE HAVE BEEN EXHAUSTED.
- STRUCTURAL PLATE PIPE DIMENSIONS ARE TO INSIDE CREST AND ARE SUBJECT TO MANUFACTURING TOLERANCES.
- SEE STANDARD PB-1 FOR BEDDING AND BACKFILL REQUIREMENTS.



ROAD AND BRIDGE STANDARDS

A COPY OF THE ORIGINAL SEALED AND SIGNED DRAWING IS ON FILE IN THE CENTRAL OFFICE.

**STRUCTURAL PLATE STEEL PIPE
HEIGHT OF COVER TABLE FOR HL-93 LIVE LOAD**

VIRGINIA DEPARTMENT OF TRANSPORTATION

SPECIFICATION
REFERENCE

SHEET 7 OF 18

REVISION DATE

107.11

11/15

232
302

**STRUCTURAL PLATE ALUMINUM ALLOY PIPE
9" x 2¹/₂" CORRUGATIONS**

PIPE DIAMETER INCHES	AREA SQ. FT.	MAXIMUM HEIGHT OF COVER IN FEET						
		SHEET THICKNESS IN INCHES						
		0.10	0.125	0.15	0.175	0.20	0.225	0.25
60	20	59	74	90	105	120	136	151
66	24	53	67	81	95	109	123	137
72	28	48	61	74	87	100	112	125
78	33	44	56	68	80	92	103	115
84	38	41	52	63	74	85	96	107
90	44	38	48	58	68	79	89	99
96	50	35	44	54	64	73	83	93
102	57	32	41	50	60	69	78	88
108	64	30	39	47	56	64	73	82
114	71	28	36	44	53	61	69	77
120	78	26	34	42	49	57	65	73
132	95	23	30	37	44	51	58	65
144	113	20	27	33	40	46	53	59
156	133		24	30	36	42	48	54
168	154			27	33	38	44	49
180	177				30	35	40	45
192	201					32	37	42
204	227					29	34	39
216	254						31	36
228	284							33

NOTES:

- COVER HEIGHTS INDICATED IN TABLE ARE FOR FINISHED CONSTRUCTION, USING AASHTO LRFD BRIDGE DESIGN SPECIFICATIONS AND ASSUMING 25% METAL LOSS AT END OF DESIGN LIFE.
- TO PROTECT PIPE DURING CONSTRUCTION, MINIMUM HEIGHT OF COVER PRIOR TO ALLOWING CONSTRUCTION TRAFFIC TO CROSS INSTALLATION SHALL BE $\frac{1}{2}$ DIAMETER. THIS COVER SHALL EXTEND THE FULL LENGTH OF THE PIPE. THE APPROACH FILL RAMP IS TO EXTEND A MINIMUM OF 10(DIAMETER + 36") ON EACH SIDE OF THE PIPE OR TO THE INTERSECTION WITH A CUT.
- STANDARD MINIMUM FINISHED HEIGHT OF COVER FOR ALL PIPES SHALL BE 2.0' OR $\frac{1}{2}$ DIAMETER, WHICHEVER IS GREATER. IN CASES IN WHICH THESE COVER HEIGHTS CANNOT BE ACHIEVED, AND ABSOLUTE MINIMUM FINISHED COVER HEIGHT OF 1.0' OR $\frac{1}{8}$ DIAMETER, WHICHEVER IS GREATER, WILL BE ALLOWED ONLY IF ALL POSSIBLE MEANS TO OBTAIN THE STANDARD VALUE HAVE BEEN EXHAUSTED.
- SEE STANDARD PB-1 FOR PIPE BEDDING AND BACKFILL REQUIREMENTS.
- STEEL BOLTS ONLY TO BE USED. BOLTS ARE $\frac{3}{4}$ " DIAMETER HIGH STRENGTH TO MEET CURRENT AASHTO DESIGNATION M-164 AND GALVANIZED TO MEET CURRENT ASTM DESIGNATION A-394. BOLTS ARE TO BE LOCATED IN THE VALLEY AND CREST OF EACH CORRUGATION IN DOUBLE ROWS SPACED $1\frac{3}{4}$ " APART.

SPECIFICATION
REFERENCE232
302

A COPY OF THE ORIGINAL SEALED AND SIGNED DRAWING IS ON FILE IN THE CENTRAL OFFICE.
STRUCTURAL PLATE ALUMINUM ALLOY PIPE
HEIGHT OF COVER TABLE FOR HL-93 LIVE LOAD
 VIRGINIA DEPARTMENT OF TRANSPORTATION

VDOT

ROAD AND BRIDGE STANDARDS

REVISION DATE

11/15

SHEET 8 OF 18

107.12

MINIMUM THICKNESS-STRUCTURAL PLATE STEEL PIPE ARCHES 6" x 2" CORRUGATIONS

PIPE ARCH DIMENSION				MINIMUM SHEET THICKNESS REQUIRED GAUGE	MAXIMUM ALLOWABLE COVER HEIGHT IN FEET	
NOMINAL SIZE		AREA SQ. FT.	Rc INCHES		MAXIMUM CORNER PRESSURE	
SPAN	RISE				4000 LBS./SQ.FT. (SEE NOTE 4)	6000 LBS./SQ.FT. (SEE NOTE 6)
6'-1"	4'-7"	22	18	12	16	24
6'-4"	4'-9"	24	18	12	15	23
6'-9"	4'-11"	26	18	12	14	22
7'-0"	5'-1"	28	18	12	14	21
7'-3"	5'-3"	31	18	12	13	20
7'-8"	5'-5"	33	18	12	12	19
7'-11"	5'-7"	35	18	12	12	18
8'-2"	5'-9"	38	18	12	12	18
8'-7"	5'-11"	40	18	12	11	17
8'-10"	6'-1"	43	18	12	11	16
9'-4"	6'-3"	46	18	12	10	16
9'-6"	6'-5"	49	18	12	10	15
9'-9"	6'-7"	52	18	12	10	15
10'-3"	6'-9"	55	18	12	9	14
10'-8"	6'-11"	58	18	12	9	14
10'-11"	7'-1"	61	18	12	9	13
11'-5"	7'-3"	64	18	12	8	13
11'-7"	7'-5"	67	18	12	8	12
11'-10"	7'-7"	71	18	12	8	12
12'-4"	7'-9"	74	18	12	8	12
12'-6"	7'-11"	78	18	12	8	12
12'-8"	8'-1"	81	18	12	7	11
12'-10"	8'-4"	85	18	12	7	11
13'-5"	8'-5"	89	18	12	7	11
13'-11"	8'-7"	93	18	12	7	10
14'-1"	8'-9"	97	18	12	7	10
14'-3"	8'-11"	101	18	12	6	10
14'-10"	9'-1"	105	18	12	6	10
15'-4"	9'-3"	109	18	12	6	9
15'-6"	9'-5"	113	18	12	6	9
15'-8"	9'-7"	118	18	12	6	9
15'-10"	9'-10"	122	18	12	6	9
16'-5"	9'-11"	126	18	12	6	9
16'-7"	10'-1"	131	18	12	6	9

NOTES:

1. COVER HEIGHTS INDICATED IN TABLES ARE FOR FINISHED CONSTRUCTION WHICH MATCH FORMER VDOT ALLOWABLE STRESS DESIGN TABLES. COVER HEIGHTS WERE NOT RE-CALCULATED USING LRFD.
2. TO PROTECT PIPE DURING CONSTRUCTION, MINIMUM HEIGHT OF COVER PRIOR TO ALLOWING CONSTRUCTION TRAFFIC TO CROSS INSTALLATION SHALL BE 1/2 SPAN. THE COVER SHALL EXTEND THE FULL LENGTH OF THE PIPE ARCH. THE APPROACH FILL RAMP IS TO EXTEND A MINIMUM OF 10(HHEIGHT + 1/2 SPAN) ON EACH SIDE OF THE STRUCTURE, OR TO THE INTERSECTION WITH A CUT.
3. STANDARD MINIMUM FINISHED HEIGHT OF COVER FOR ALL PIPES SHALL BE 2.0' OR 1/2 SPAN, WHICHEVER IS GREATER. IN CASES IN WHICH THESE COVER HEIGHTS CANNOT BE ACHIEVED, AN ABSOLUTE MINIMUM FINISHED COVER HEIGHT OF 1.0' OR 1/8 SPAN, WHICHEVER IS GREATER, WILL BE ALLOWED ONLY IF ALL POSSIBLE MEANS TO OBTAIN THE STANDARD VALUE HAVE BEEN EXHAUSTED.
4. SEE STANDARD PB-1 FOR PIPE BEDDING AND BACKFILL REQUIREMENTS.
5. THE MAXIMUM HEIGHT OF COVER SHOWN IN THE TABLES IS BASED ON A SOIL MODULUS OF 700 PSI. ALL OTHER DESIGN CRITERIA ARE IN ACCORDANCE WITH THE AASHTO SPECIFICATIONS AND VDOT MODIFICATIONS FOR SOIL CORRUGATED METAL STRUCTURE INTERACTION SYSTEMS.
6. WHEN DESIGN HEIGHT OF COVER REQUIRES THE USE OF THIS CATEGORY OF PIPE, BEDDING AND BACKFILL MUST BE APPROVED BY THE ENGINEER.
7. STRUCTURAL PLATE PIPE-ARCH DIMENSIONS ARE TO INSIDE OF CREST AND ARE SUBJECT TO MANUFACTURING TOLERANCES.

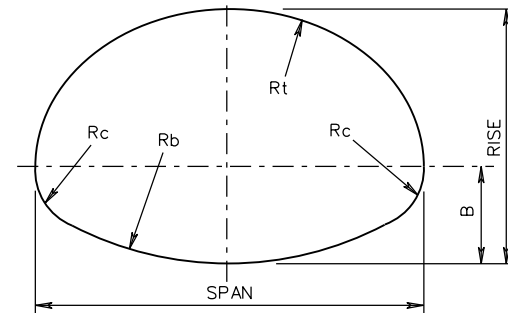

MINIMUM THICKNESS-STRUCTURAL PLATE STEEL PIPE ARCHES 6" x 2" CORRUGATIONS

PIPE ARCH DIMENSION				MINIMUM SHEET THICKNESS REQUIRED GAUGE	MAXIMUM ALLOWABLE COVER HEIGHT IN FEET	
SPAN	RISE	AREA SQ. FT.	Rc INCHES		MAXIMUM CORNER PRESSURE	
					4000 LBS./SQ. FT. (SEE NOTE 4)	6000 LBS./SQ. FT. (SEE NOTE 6)
13'-3'	9'-4"	97	31	12	12	18 ☉
13'-6'	9'-6"	102	31	12	12	17 ☉
14'-0"	9'-8"	105	31	12	12	17 ☉
14'-2"	9'-10"	109	31	12	12	16 ☉
14'-5"	10'-0"	114	31	12	11	16 ☉
14'-11"	10'-2"	118	31	12	11	16 ☉
15'-4"	10'-4"	123	31	12	11	15 ☉
15'-7"	10'-6"	127	31	12	11	15 ☉
15'-10"	10'-8"	132	31	12	10	14 ☉
16'-3"	10'-10"	137	31	12	10	14 ☉
16'-6"	11'-0"	142	31	12	10	14 ☉
17'-0"	11'-2"	146	31	12	10	14 ☉
17'-2"	11'-4"	151	31	12	10	13 ☉
17'-5"	11'-6"	157	31	12	9	13 ☉
17'-11"	11'-8"	161	31	12	9	13 ☉
18'-1"	11'-10"	167	31	12	9	13 ☉
18'-7"	12'-0"	172	31	12	9	12 ☉
18'-9"	12'-2"	177	31	12	9	12 ☉
19'-3"	12'-4"	182	31	10	8	13
19'-6"	12'-6"	188	31	10	8	13
19'-8"	12'-8"	194	31	10	8	13
19'-11"	12'-10"	200	31	10	8	12
20'-5"	13'-0"	205	31	10	8	12
20'-7"	13'-2"	211	31	10	8	12

☉ MAXIMUM COVER HEIGHTS SHOWN MAY BE INCREASED BY A MAXIMUM OF 12" IF A SHEET THICKNESS GREATER THAN 12 GAUGE IS USED.

NOTES:

1. COVER HEIGHTS INDICATED IN TABLES ARE FOR FINISHED CONSTRUCTION WHICH MATCH FORMER VDOT ALLOWABLE STRESS DESIGN TABLES. COVER HEIGHTS WERE NOT RE-CALCULATED USING LRFD.
2. TO PROTECT PIPE DURING CONSTRUCTION, MINIMUM HEIGHT OF COVER PRIOR TO ALLOWING CONSTRUCTION TRAFFIC TO CROSS INSTALLATION SHALL BE 1/2 SPAN. THE COVER SHALL EXTEND THE FULL LENGTH OF THE PIPE ARCH. THE APPROACH FILL RAMP IS TO EXTEND A MINIMUM OF 10(HHEIGHT + 1/2 SPAN) ON EACH SIDE OF THE STRUCTURE OR TO THE INTERSECTION WITH A CUT.
3. STANDARD MINIMUM FINISHED HEIGHT OF COVER FOR ALL PIPES SHALL BE 1/4 SPAN. IN CASES IN WHICH THIS COVER HEIGHT CANNOT BE ACHIEVED, AN ABSOLUTE MINIMUM FINISHED COVER HEIGHT OF 1/8 SPAN WILL BE ALLOWED ONLY IF ALL POSSIBLE MEANS TO OBTAIN THE STANDARD VALUE HAVE BEEN EXHAUSTED.
4. SEE STANDARD PB-1 FOR PIPE BEDDING AND BACKFILL REQUIREMENTS.
5. STRUCTURAL PLATE PIPE-ARCH DIMENSIONS ARE TO INSIDE OF CREST AND ARE SUBJECT TO MANUFACTURING TOLERANCES.
6. WHEN DESIGN HEIGHT OF COVER REQUIRES THE USE OF THIS CATEGORY OR PIPE, BEDDING AND BACKFILL MUST BE APPROVED BY THE ENGINEER.
7. THE MAXIMUM HEIGHT OF COVER SHOWN IN THE TABLES IS BASED ON A SOIL MODULUS OF 700 PSI. ALL OTHER DESIGN CRITERIA ARE IN ACCORDANCE WITH THE AASHTO SPECIFICATIONS AND VDOT MODIFICATIONS FOR SOIL CORRUGATED METAL STRUCTURE INTERACTION SYSTEMS.

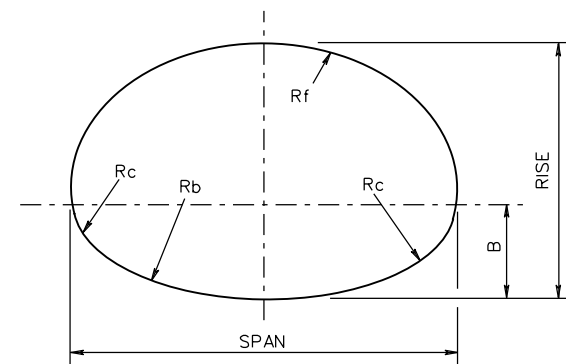

SPECIFICATION REFERENCE

232
302

A COPY OF THE ORIGINAL SEALED AND SIGNED DRAWING IS ON FILE IN THE CENTRAL OFFICE.

STRUCTURAL PLATE STEEL PIPE ARCH HEIGHT OF COVER TABLE FOR HL-93 LIVE LOAD

VIRGINIA DEPARTMENT OF TRANSPORTATION

VDOT

ROAD AND BRIDGE STANDARDS

REVISION DATE

11/15

SHEET 10 OF 5

107.14

STRUCTURAL PLATE ALUMINUM ALLOY PIPE ARCHES 9' x 2 1/2" CORRUGATIONS

SPAN	RISE	CORNER RADIUS	MAXIMUM COVER HEIGHT IN FEET								AREA SQ.FT.
			MINIMUM SHEET THICKNESS IN INCHES								
			MAXIMUM CORNER PRESSURE IN LBS./SQ. FT.								
			0.100"		0.125"		0.150"		0.175"		
			4000 (SEE NOTE 4)	4000 (SEE NOTE 4)	6000 (SEE NOTE 6)	4000 (SEE NOTE 4)	6000 (SEE NOTE 6)	4000 (SEE NOTE 6)	6000 (SEE NOTE 6)		
6'-2"	5'-0"	31.8	25	28	36	28	42	28	42	24.7	
6'-7"	4'-11"	31.8	23	26	34	26	40	26	40	26.6	
6'-7"	5'-8"	31.8	23	26	34	26	40	26	40	29.6	
6'-11"	5'-9"	31.8	22	25	32	25	38	25	38	31.9	
7'-3"	5'-11"	31.8	21	24	31	24	36	24	36	34.3	
7'-9"	6'-0"	31.8	20	22	29	22	34	22	34	36.8	
8'-1"	6'-1"	31.8	19	21	28	21	32	21	32	39.3	
8'-5"	6'-3"	31.8	18	20	27	20	31	20	31	41.9	
8'-10"	6'-4"	31.8	17	20	25	20	30	20	30	44.5	
9'-3"	6'-5"	31.8	16	19	24	19	28	19	28	45.1	
9'-7"	6'-6"	31.8	16	18	23	18	27	18	27	49.9	
9'-11"	6'-8"	31.8	15	17	22	17	26	17	26	52.7	
10'-3"	6'-9"	31.8	15	17	22	17	25	17	25	55.5	
10'-9"	6'-10"	31.8	14	16	21	16	24	16	24	58.4	
11'-1"	7'-0"	31.8	14	15	20	15	23	15	23	61.4	
11'-5"	7'-1"	31.8	13	15	19	15	23	15	23	64.4	
11'-9"	7'-2"	31.8	13	15	19	15	22	15	22	67.5	
12'-3"	7'-3"	31.8	12	14	18	14	21	14	21	70.5	
12'-7"	7'-5"	31.8	12	14	18	14	21	14	21	73.7	
12'-11"	7'-6"	31.8	12	13	17	13	20	13	20	77.0	
13'-1"	8'-2"	31.8	11	13	17	13	20	13	20	83.0	
13'-1"	8'-4"	31.8	11	13	17	13	20	13	20	86.8	
13'-11"	8'-5"	31.8	11	12	16	12	19	12	19	90.3	
14'-0"	8'-7"	31.8	11	12	16	12	18	12	18	94.2	
13'-11"	9'-5"	31.8	11	12	16	12	19	12	19	101.5	
14'-3"	9'-7"	31.8	10	12	15	12	18	12	18	105.7	
14'-8"	9'-8"	31.8		12	14	12	17	12	18	109.9	
14'-11"	9'-10"	31.8		11	13	11	16	11	17	114.2	
15'-4"	10'-0"	31.8		11	12	11	14	11	17	118.6	
15'-7"	10'-2"	31.8		11	11	11	14	11	16	123.1	
16'-1"	10'-4"	31.8		10		10	12	10	15	127.6	
16'-4"	10'-6"	31.8				10	12	10	14	132.3	
16'-9"	10'-8"	31.8				10	11	10	13	136.9	
17'-0"	10'-10"	31.8				10		10	12	141.8	
17'-3"	11'-0"	31.8				10		10	12		
18'-0"	11'-4"	31.8						9	10		

NOTES:

1. COVER HEIGHTS INDICATED IN TABLES ARE FOR FINISHED CONSTRUCTION WHICH MATCH FORMER VDOT ALLOWABLE STRESS DESIGN TABLES. COVER HEIGHTS WERE NOT RE-CALCULATED USING LRFD.
2. TO PROTECT PIPE DURING CONSTRUCTION, MINIMUM HEIGHT OF COVER PRIOR TO ALLOWING CONSTRUCTION TRAFFIC TO CROSS INSTALLATION TO BE 1/2 SPAN. THE COVER SHALL EXTEND THE FULL LENGTH OF THE PIPE ARCH. THE APPROACH FILL RAMP IS TO EXTEND A MINIMUM OF 10(RISE + 1/2 SPAN) ON EACH SIDE OF THE PIPE, OR TO THE INTERSECTION WITH A CUT.
3. STANDARD MINIMUM FINISHED HEIGHT OF COVER FOR ALL PIPES SHALL BE 2.0' OR 1/4 SPAN, WHICHEVER IS GREATER. IN CASES IN WHICH THESE COVER HEIGHTS CANNOT BE ACHIEVED, AN ABSOLUTE MINIMUM FINISHED COVER HEIGHT OF 1.0' OR 1/8 SPAN, WHICHEVER IS GREATER, WILL BE ALLOWED ONLY IF ALL POSSIBLE MEANS TO OBTAIN THE STANDARD VALUE HAVE BEEN EXHAUSTED.
4. SEE STANDARD PB-1 FOR BEDDING AND BACKFILL REQUIREMENTS.
5. THE MAXIMUM HEIGHT OF COVER SHOWN IN THE TABLES IS BASED ON A SOIL MODULUS OF 700 PSI. ALL OTHER DESIGN CRITERIA ARE IN ACCORDANCE WITH THE AASHTO SPECIFICATIONS AND VDOT MODIFICATIONS FOR SOIL CORRUGATED METAL STRUCTURE INTERACTION SYSTEMS.
6. WHEN DESIGN HEIGHT OF COVER REQUIRES THE USE OF THIS CATEGORY OF PIPE, BEDDING AND BACKFILL MUST BE APPROVED BY THE ENGINEER.
7. BOLTS ARE 3/4" DIAMETER, HIGH STRENGTH TO MEET CURRENT A.S.T.M. DESIGNATION M-164 AND GALVANIZED TO MEET CURRENT A.S.T.M. DESIGNATION A-394. BOLTS ARE TO BE LOCATED IN THE VALLEY AND CREST OF EACH CORRUGATION IN DOUBLE ROWS SPACED 1 3/4" APART.
8. STRUCTURAL PLATE PIPE-ARCH DIMENSIONS ARE TO INSIDE CREST AND ARE SUBJECT TO MANUFACTURING TOLERANCES.

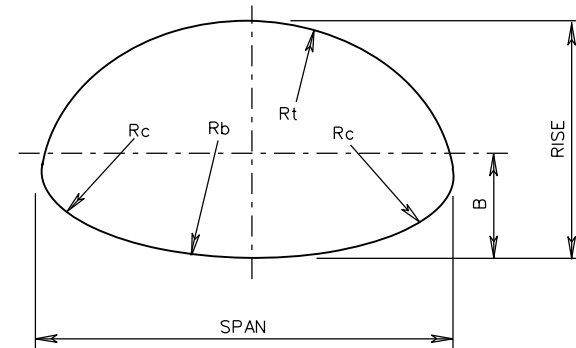

ROAD AND BRIDGE STANDARDS

SHEET 11 OF 18

REVISION DATE

107.15

11/15

A COPY OF THE ORIGINAL SEALED AND SIGNED DRAWING IS ON FILE IN THE CENTRAL OFFICE.
STRUCTURAL PLATE ALUMINUM ALLOY PIPE ARCH
HEIGHT OF COVER TABLE FOR HL-93 LIVE LOAD
 VIRGINIA DEPARTMENT OF TRANSPORTATION

SPECIFICATION REFERENCE

232
302

ALUMINUM SPIRAL RIB PIPE 3/4" WIDE x 3/4" DEEP RIBS SPACED @ 7 1/2"

PIPE DIAMETER INCHES	AREA SQ. FT.	MAXIMUM HEIGHT OF COVER IN FEET				MINIMUM SHEET THICKNESS FOR ENTRANCE PIPES WITH LESS THAN 1 FT. COVER INCHES (GAUGE)
		SHEET THICKNESS IN INCHES (GAUGE)				
		0.06 (16)	0.075 (14)	0.105 (12)	0.135 (10)	
12	0.8	75	103	166		0.064 (16)
15	1.2	59	82	133	188	0.075 (14)
18	1.8	49	68	110	156	0.075 (14)
21	2.4	42	58	94	134	0.105 (12)
24	3.1	36	50	82	117	0.105 (12)
27	4.0	32	44	73	103	0.105 (12)
30	4.9	28	40	65	93	0.105 (12)
36	7.1	23	33	54	77	0.105 (12)
42	9.6	19	27	46	65	0.105 (12)
48	12.6	16	23	39	57	0.105 (12)
54	16.0	13	20	35	50	0.105 (12)
60	19.6	11	17	31	45	0.105 (12)
66	23.8	9	15	27	40	0.105 (12)
72	28.3	7	13	25	36	0.105 (12)

NOTES:

- COVER HEIGHTS INDICATED IN TABLE ARE FOR FINISHED CONSTRUCTION, USING AASHTO LRFD BRIDGE DESIGN SPECIFICATIONS AND ASSUMING 25% METAL LOSS AT END OF DESIGN LIFE.
- TO PROTECT PIPE DURING CONSTRUCTION, MINIMUM HEIGHT OF COVER TO BE IN ACCORDANCE WITH TABLE A PRIOR TO ALLOWING CONSTRUCTION TRAFFIC TO CROSS INSTALLATION. THE COVER SHALL EXTEND THE FULL LENGTH OF THE PIPE. THE APPROACH FILL RAMP IS TO EXTEND A MINIMUM OF 20 DIAMETERS ON EACH SIDE OF THE PIPE, OR TO THE INTERSECTION WITH A CUT.
- STANDRD MINIMUM FINISHED HEIGHT OF COVER FOR ALL PIPES, EXCEPT THOSE UNDER ENTRANCES, SHALL BE 2'0" OR 1/2 DIAMETER, WHICHEVER IS GREATER. IN CASES IN WHICH THESE COVER HEIGHTS CANNOT BE ACHIEVED, AN ABSOLUTE MINIMUM FINISHED COVER HEIGHT OF 1.0' OR 1/4 DIAMETER, WHICHEVER IS GREATER, WILL BE ALLOWED ONLY IF ALL POSSIBLE MEANS TO OBTAIN THE STANDARD VALUE HAVE BEEN EXHAUSTED. THE MINIMUM FINISHED HEIGHT OF COVER FOR PIPES UNDER ENTRANCES IS 9" FOR PIPE DIAMETERS LESS THAN OR EQUAL TO 18" AND 12" OR 1/4 DIAMETER, WHICHEVER IS GREATER, FOR PIPE DIAMETERS GREATER THAN 18".
- SEE STANDARD PB-1 FOR PIPE BEDDING AND BACKFILL REQUIREMENTS.

PIPE DIAMETER	MINIMUM COVER HEIGHT DURING CONSTRUCTION (SEE NOTE 2)
12" TO 27"	18"
30" AND OVER	EQUAL TO DIAMETER

SPECIFICATION REFERENCE

232
302

A COPY OF THE ORIGINAL SEALED AND SIGNED DRAWING IS ON FILE IN THE CENTRAL OFFICE.

ALUMINUM SPIRAL RIB PIPE
HEIGHT OF COVER TABLE FOR HL-93 LIVE LOAD
VIRGINIA DEPARTMENT OF TRANSPORTATION



ROAD AND BRIDGE STANDARDS

REVISION DATE

11/15

SHEET 12 OF 18

107.16

STEEL SPIRAL RIB PIPE 3/4" WIDE x 3/4" RIBS SPACED @ 7 1/2"

PIPE DIAMETER INCHES	AREA SQ. FT.	MAXIMUM HEIGHT OF COVER IN FEET				MINIMUM SHEET THICKNESS FOR ENTRANCE PIPES WITH LESS THAN 1 FT. COVER INCHES (GAUGE)
		SHEET THICKNESS IN INCHES (GAUGE)				
		0.064 (16)	0.079 (14)	0.109 (12)	0.138 (10)	
18	1.8	101	142			0.064 (16)
21	2.4	86	121	203		0.064 (16)
24	3.1	75	106	177		0.064 (16)
27	4.0	67	94	157		0.064 (16)
30	4.9	60	84	141		0.064 (16)
36	7.1	49	70	117		0.064 (16)
42	9.6	42	59	100		0.064 (16)
48	12.6	36	51	87	127	0.064 (16)
54	16.0		45	77	113	0.079 (14)
60	19.6		40	69	101	0.079 (14)
66	23.8			62	92	0.109 (12)
72	28.3			57	84	0.109 (12)
78	33.2			52	77	0.109 (12)
84	38.6				71	0.138 (10)
90	44.17				66	0.138 (10)

NOTES:

- COVER HEIGHTS INDICATED IN TABLE ARE FOR FINISHED CONSTRUCTION, USING AASHTO LRFD BRIDGE DESIGN SPECIFICATIONS AND ASSUMING 25% METAL LOSS AT END OF DESIGN LIFE.
- TO PROTECT PIPE DURING CONSTRUCTION, MINIMUM HEIGHT OF COVER TO BE IN ACCORDANCE WITH TABLE A PRIOR TO ALLOWING CONSTRUCTION TRAFFIC TO CROSS INSTALLATION. THE COVER SHALL EXTEND THE FULL LENGTH OF THE PIPE. THE APPROACH FILL IS TO EXTEND A MINIMUM OF 15 DIAMETERS ON EACH SIDE OF THE PIPE OR TO THE INTERSECTION WITH THE CUT.
- MINIMUM FINISHED HEIGHT OF COVER FOR ALL PIPES, EXCEPT THOSE UNDER ENTRANCES, SHALL BE 2.0' OR 1/2 DIAMETER, WHICHEVER IS GREATER. IN CASES IN WHICH THESE COVER HEIGHTS CANNOT BE ACHIEVED, AN ABSOLUTE MINIMUM FINISHED COVER HEIGHT OF 1.0' OR 1/4 DIAMETER, WHICHEVER IS GREATER, WILL BE ALLOWED ONLY IF ALL POSSIBLE MEANS TO OBTAIN THE STANDARD VALUE HAVE BEEN EXHAUSTED. THE MINIMUM FINISHED HEIGHT OF COVER FOR PIPES UNDER ENTRANCES IS 9" FOR PIPE DIAMETERS LESS THAN OR EQUAL TO 24" AND 12" OR 1/4 DIAMETER, WHICHEVER IS GREATER, FOR PIPE DIAMETERS GREATER THAN 24". WHERE POLYMER COATED PIPE WILL BE USED AND THE SURFACE OVER THE TOP OF THE PIPE WILL BE ASPHALT, CLASS I BACKFILL MATERIAL IS TO BE PLACED UP TO A MINIMUM OF 6" ABOVE THE TOP OF THE PIPE.
- SEE STANDARD PB-1 FOR PIPE BEDDING AND BACKFILL REQUIREMENTS.
- A MAXIMUM HEIGHT OF COVER TABLE FOR STEEL SPIRAL RIB WITH 3/4" WIDE x 1" DEEP RIBS SPACED AT 11/2" IS AVAILABLE UPON REQUEST.

PIPE DIAMETER	MINIMUM COVER HEIGHT DURING CONSTRUCTION (SEE NOTE 2)
12" TO 30"	18"
36" AND ABOVE	1/2 DIAMETER



ROAD AND BRIDGE STANDARDS

A COPY OF THE ORIGINAL SEALED AND SIGNED STANDARD DRAWING IS ON FILE IN THE CENTRAL OFFICE

STEEL SPIRAL RIB PIPE
HEIGHT OF COVER TABLE FOR HL-93 LIVE LOAD
VIRGINIA DEPARTMENT OF TRANSPORTATION

SPECIFICATION REFERENCE

SHEET 13 OF 18

REVISION DATE

107.17

11/15

232
302

CAST IRON PIPE CULVERT DESIGNATION				
DIAMETER INCHES	AREA SQ. FT.	MAXIMUM HEIGHT OF COVER IN FEET		
		1-13	14-21	22-35 (2)
12 (2)	0.8	STANDARD PIPE	HEAVY PIPE	EXTRA HEAVY PIPE
15 (3)	1.2			
16 (2) (4)	1.4			
18 (1)	1.8			
24 (1)	3.1			
30 (1)	4.9			
36 (1)	7.1			
42 (2)	9.6			
48 (2)	12.6			

- (1) PIPE MAY BE SMOOTH CAST IRON, CORRUGATED CAST IRON, OR RIBBED CAST IRON.
- (2) PIPE TO BE SMOOTH CAST IRON ONLY.
- (3) PIPE TO BE CORRUGATED CAST IRON OR RIBBED CAST IRON.
- (4) MAY BE SUBSTITUTED FOR 15" PIPE CULVERT AT NO INCREASE IN PRICE BID FOR 15" PIPE, WHERE APPROVED BY THE ENGINEER.

NOTES:

- 1. COVER HEIGHTS INDICATED IN TABLES ARE FOR FINISHED CONSTRUCTION WHICH MATCH FORMER VDOT ALLOWABLE STRESS DESIGN TABLES. COVER HEIGHTS WERE NOT RE-CALCULATED USING LRFD
- 2. TO PROTECT PIPE DURING CONSTRUCTION, MINIMUM HEIGHT OF COVER PRIOR TO ALLOWING CONSTRUCTION TRAFFIC TO CROSS INSTALLATION IS TO BE 24". THIS COVER IS TO EXTEND THE FULL LENGTH OF THE PIPE CULVERT. THE APPROACH FILL RAMP IS TO EXTEND A MINIMUM OF 10 (DIAMETER + 36") ON EACH SIDE OF THE CULVERT, OR TO THE INTERSECTION WITH A CUT.
- 3. MINIMUM FINISHED HEIGHT OF COVER TO BE 24", EXCEPT PIPE UNDER ENTRANCES AND MEDIAN CROSSOVERS WHERE A 9" MINIMUM WILL BE PERMITTED.
- 4. SEE STANDARD PB-1 FOR PIPE BEDDING AND BACKFILL REQUIREMENTS.

SPECIFICATION REFERENCE
232 302

A COPY OF THE ORIGINAL SEALED AND SIGNED STANDARD DRAWING IS ON FILE IN THE CENTRAL OFFICE

CAST IRON PIPE
HEIGHT OF COVER TABLE FOR HL-93 LIVE LOAD
 VIRGINIA DEPARTMENT OF TRANSPORTATION

VDOT ROAD AND BRIDGE STANDARDS	
REVISION DATE	SHEET 14 OF 18
11/15	107.18

POLYETHYLENE CORRUGATED PIPE (PE)

(SEE NOTE 5)

DIAMETER INCHES	AREA SQ. FT.	MAXIMUM HEIGHT OF COVER FEET
12	0.8	24
15	1.2	24
18	1.8	20
24	3.1	20
30	4.9	19
36	7.1	18
42	9.6	18
48	12.6	17
54	15.9	16
60	19.6	16

NOTES:

- COVER HEIGHTS INDICATED IN TABLES ARE FOR FINISHED CONSTRUCTION, USING AASHTO LRFD BRIDGE DESIGN SPECIFICATIONS.
- TO PROTECT PIPE DURING CONSTRUCTION, MINIMUM HEIGHT OF COVER TO BE IN ACCORDANCE WITH TABLE A PRIOR TO ALLOWING CONSTRUCTION TRAFFIC TO CROSS INSTALLATION. THE COVER SHALL EXTEND THE FULL LENGTH OF THE PIPE. THE APPROACH FILL IS TO EXTEND A MINIMUM OF 10(DIAMETER + 1/2 DIAMETER) ON EACH SIDE OF THE PIPE OR TO THE INTERSECTION WITH A CUT.
- STANDARD MINIMUM FINISHED HEIGHT OF COVER FOR ALL PIPES, EXCEPT THOSE UNDER ENTRANCES, SHALL BE 2.0' OR 1/2 DIAMETER WHICHEVER IS GREATER. FOR 12" THROUGH 48" DIAMETER PIPE INSTALLATIONS WHERE THE COVER HEIGHTS CANNOT BE ACHIEVED, AN ABSOLUTE MINIMUM FINISHED COVER HEIGHT OF 1.0' WILL BE ALLOWED ONLY IF ALL POSSIBLE MEANS TO OBTAIN THE STANDARD VALUE HAVE BEEN EXHAUSTED. THE MINIMUM FINISHED HEIGHT OF COVER FOR PIPES UNDER ENTRANCES IS 9" FOR PIPE DIAMETERS LESS THAN OR EQUAL TO 24", AND 12" FOR PIPE DIAMETERS GREATER THAN 24". WHERE THE SURFACE OVER THE TOP OF THE PIPE WILL BE ASPHALT, A MINIMUM OF 6" OF CLASS 1 BACKFILL MATERIAL IS TO BE PLACED BETWEEN THE TOP OF THE PIPE AND THE BOTTOM OF THE ASPHALT.
- SEE STANDARD PB-1 FOR PIPE BEDDING AND BACKFILL REQUIREMENTS.
- HEIGHT OF COVER VALUES FOR 12" THROUGH 36" DIAMETER APPLY TO TYPE C OR S. HEIGHT OF COVER VALUES FOR 42" THROUGH 60" APPLY TO TYPE S ONLY.
- HEIGHT OF COVER VALUES FOR 12" THROUGH 30" DIAMETER APPLY TO TYPE S. HEIGHT OF COVER VALUES FOR 36" THROUGH 60" APPLY TO TYPE D.
- LARGE CULVERTS SHALL BE DESIGNED BY AN ENGINEER, REGISTERED IN THE COMMONWEALTH OF VIRGINIA, AND SHALL BE DESIGNED IN ACCORDANCE WITH THE REQUIREMENTS OF VOLUME V, PART 2 OF THE MANUAL OF THE STRUCTURE AND BRIDGE DIVISION. A LARGE CULVERT IS ANY CULVERT THAT WILL BECOME PART OF THE STRUCTURE AND BRIDGE INVENTORY. THE GEOMETRIC DEFINITION OF THESE STRUCTURES IS PROVIDED IN THE CURRENT VERSION OF VDOT'S IM-S&B-27.

POLYVINYLCHLORIDE PROFILE WALL PIPE (PVC)

DIAMETER INCHES	AREA SQ. FT.	MAXIMUM HEIGHT OF COVER FEET
18	1.7	41
21	2.3	40
24	3.0	37
30	4.7	34
36	6.9	34

POLYPROPYLENE PIPE (PP)

(SEE NOTE 6)

DIAMETER INCHES	AREA SQ. FT.	MAXIMUM HEIGHT OF COVER FEET
12	0.8	25
15	1.2	25
18	1.8	21
24	3.1	20
30	4.9	19
36	7.1	18
42	9.6	18
48	12.6	17
60	19.6	17

TABLE A

PIPE DIAMETER	MINIMUM COVER HEIGHT DURING CONSTRUCTION (SEE NOTE 2)
12" TO 30"	18"
36" AND ABOVE	1/2 DIAMETER



ROAD AND BRIDGE STANDARDS

A COPY OF THE ORIGINAL SEALED AND SIGNED STANDARD DRAWING IS ON FILE IN THE CENTRAL OFFICE

**PLASTIC PIPE
HEIGHT OF COVER TABLES FOR HL-93 LIVE LOAD**
VIRGINIA DEPARTMENT OF TRANSPORTATION

SPECIFICATION
REFERENCE

SHEET 15 OF 18

REVISION DATE

107.19

11/15

232
302

TABLE A - ALLOWABLE TYPE OF PIPE CULVERT FOR ROADWAYS THAT ARE CONSTRUCTED, FUNDED OR WILL ULTIMATELY BE MAINTAINED BY VDOT					
FUNCTIONAL CLASSIFICATION OF ROADS SYSTEM UNDER WHICH PIPE IS TO BE INSTALLED					ENTRANCE PIPE
HIGHER FUNCTIONAL CLASS - HFC 75 - YEAR DESIGN LIFE RURAL PRINCIPAL ARTERIAL, URBAN PRINCIPAL ARTERIAL, RURAL MINOR ARTERIAL, URBAN MINOR ARTERIAL, RURAL COLLECTOR ROADS, URBAN COLLECTOR STREETS, SUBDIVISION STREETS WITH AN ADT GREATER THAN 4000			LOWER FUNCTIONAL CLASS - LFC 50 - YEAR DESIGN LIFE RURAL LOCAL ROADS, URBAN LOCAL STREETS, SUBDIVISION STREETS WITH AN ADT LESS THAN OR EQUAL TO 4000		
ALLOWABLE PIPE CULVERTS NOTES 1 & 2	STATEWIDE EXCEPT LOCATIONS SHOWN IN TABLE B	LOCATION SHOWN IN TABLE B	STATEWIDE EXCEPT LOCATIONS SHOWN IN TABLE B	LOCATION SHOWN IN TABLE B	STATEWIDE
CONCRETE	✓	✓	✓	✓	✓
ALUMINUM COATED TYPE 2 CORRUGATED STEEL NOTE 3	✓		✓		✓
POLYMER COATED (10/10) CORRUGATED STEEL NOTE 3	✓	✓	✓	✓	✓
UNCOATED GALVANIZED CORRUGATED STEEL NOTES 3 & 4					✓
GALVANIZED STEEL STRUCTURAL PLATE NOTE 3			✓		✓
GALVANIZED STEEL STRUCTURAL PLATE WITH THICKENED INVERT NOTE 3, 5	✓		✓	✓	✓
CORRUGATED ALUMINUM ALLOY NOTE 3	✓	✓	✓	✓	✓
CORRUGATED ALUMINUM ALLOY STRUCTUAL PLATE NOTE 3	✓	✓	✓	✓	✓
POLYVINYLCHLORIDE (PVC) PROFILE WALL PIPE (SMOOTH INTERIOR)	✓	✓	✓	✓	✓
POLYETHYLENE (PE) CORRUGATED TYPE C	✓	✓	✓	✓	
POLYETHYLENE (PE) CORRUGATED TYPE S	✓	✓	✓	✓	✓
POLYPROPYLENE (PP) TYPE D OR S	✓	✓	✓	✓	✓

NOTES:

1. ALLOWABLE TYPES OF PIPES FOR A SPECIFIC AREA ARE TO CONFORM TO THE CRITERIA SHOWN IN TABLES A, A1, B, AND C. ANY DEVIATION MUST BE APPROVED BY THE STATE LOCATION AND DESIGN ENGINEER AND THE DISTRICT MATERIALS ENGINEER.
2. SEE HEIGHT OF COVER TABLES FOR MINIMUM AND MAXIMUM COVER LIMITATIONS FOR EACH TYPE OF PIPE.
3. SEE TABLE C FOR MINIMUM AND MAXIMUM pH, RESISTIVITY, AND VELOCITY LIMITATIONS FOR METAL PIPES. SEE TABLE D FOR REQUIRED GAUGE OF METAL PIPE.
4. USE ONLY UNDER ENTRANCES WHERE THE PIPE SIZE IS LESS THAN OR EQUAL TO 30" DIAMETER (OR EQUIVALENT) AND THE HEIGHT OF COVER IS LESS THAN OR EQUAL TO 15' AND AS AN OUTLET PIPE FOR STANDARD DI-13 SHOULDER SLOT INLETS.
5. BOTTOM AND CORNER PLATES SHALL BE 2 GAUGE STEPS THICKER

SPECIFICATION REFERENCE
232 302

A COPY OF THE ORIGINAL SEALED AND SIGNED STANDARD DRAWING IS ON FILE IN THE CENTRAL OFFICE

**ALLOWABLE PIPE CRITERIA FOR
CULVERT AND STORM SEWERS**

VIRGINIA DEPARTMENT OF TRANSPORTATION

VDOT	
ROAD AND BRIDGE STANDARDS	
REVISION DATE	SHEET 16 OF 18
11/15	107.20

TABLE A1 - ALLOWABLE TYPE OF STORM SEWER PIPE FOR ROADWAYS THAT ARE CONSTRUCTED, FUNDED OR WILL ULTIMATELY BE MAINTAINED BY VDOT			
FUNCTIONAL CLASSIFICATION OF ROADS SYSTEM UNDER WHICH PIPE IS TO BE INSTALLED			
HIGHER FUNCTIONAL CLASS - HFC 75 - YEAR DESIGN LIFE		LOWER FUNCTIONAL CLASS - LFC 50 - YEAR DESIGN LIFE	
RURAL PRINCIPAL ARTERIAL, URBAN PRINCIPAL ARTERIAL, RURAL MINOR ARTERIAL, URBAN MINOR ARTERIAL, RURAL COLLECTOR ROADS, URBAN COLLECTOR STREETS, SUBDIVISION STREETS WITH AN ADT GREATER THAN 4000		RURAL LOCAL ROADS, URBAN LOCAL STREETS, SUBDIVISION STREETS WITH AN ADT LESS THAN OR EQUAL TO 4000	
ALLOWABLE PIPE CULVERTS	STATEWIDE	STATEWIDE EXCEPT LOCATIONS SHOWN IN TABLE B	LOCATION SHOWN IN TABLE B
NOTES 1 & 2			
CONCRETE	✓	✓	✓
ALUMINUM COATED TYPE 2 STEEL SPIRAL RIB		✓	
NOTE 3			
POLYMER COATED (10/10) CORRUGATED STEEL SPIRAL RIB		✓	✓
NOTE 3			
POLYMER COATED (10/10) CORRUGATED STEEL DOUBLE WALL (SMOOTH INTERIOR)	✓	✓	✓
NOTE 3			
ALUMINUM SPIRAL RIB		✓	✓
NOTE 3			
POLYVINYLCHLORIDE (PVC) PROFILE WALL PIPE (SMOOTH INTERIOR)	✓	✓	✓
POLYETHYLENE (PE) CORRUGATED TYPE S	✓	✓	✓
POLYPROPYLENE (PP) TYPE D OR S	✓	✓	✓

TABLE B EXCEPTIONS TO STATEWIDE APPLICATIONS		
COUNTIES (INCLUDING TOWNS)	CITIES	
ARLINGTON - EAST OF AND INCLUDING RTES. 95 & 395	SURRY - EAST OF AND INCLUDING RTE. 10	SUFFOLK - EAST OF AND INCLUDING RTE. 32
FAIRFAX - EAST OF AND INCLUDING RTES. 95 & 395	ISLE OF WIGHT - EAST OF AND INCLUDING RTE. 10	CHESAPEAKE WILLIAMSBURG VIRGINIA BEACH POQUOSON
PRINCE WILLIAM - EAST OF AND INCLUDING RTES. 95 & 395		HAMPTON PORTSMOUTH
WESTMORELAND JAMES CITY	ESSEX NORTHAMPTON	NEWPORT NEWS
LANCASTER ACCOMACK	MIDDLESEX STAFFORD	NORFOLK
MATTHEWS SPOTSYLVANIA	YORK KING GEORGE	ALEXANDRIA
GLOUCESTER NORTHUMBERLAND	RICHMOND	FREDERICKSBURG

TABLE C					
PIPE TYPE	ALLOWABLE pH RANGE (SEE NOTE 6)		ALLOWABLE RESISTIVITY RANGE (Ohms-cm)		ALLOWABLE VELOCITY (FPS) (SEE NOTE 4)
	MIN.	MAX.	MIN.	MAX.	MAXIMUM
UNCOATED GALVANIZED CORRUGATED STEEL	6.0	10.0	2000	10000	5
GALVANIZED STEEL STRUCTURAL PLATE	6.0	9.0	2000	10000	5
GALVANIZED STEEL STRUCTURAL PLATE WITH THICKENED INVERT	6.0	9.0	2000	10000	15
ALUMINUM COATED TYPE 2 CORRUGATED STEEL	5.0	9.0	1500	-	5
ALUMINUM COATED TYPE 2 SPIRAL RIB	5.0	9.0	1500	-	5
CORRUGATED ALUMINUM ALLOY	4.0	9.0	1500	-	5
CORRUGATED ALUMINUM ALLOY STRUCTURAL PLATE	4.0	9.0	1500	-	5
ALUMINUM SPIRAL RIB	4.0	9.0	1500	-	5
POLYMER COATED (10/10) CORRUGATED STEEL	4.0	9.0	750	-	10
POLYMER COATED CORRUGATED STEEL SPIRAL RIB	4.0	9.0	750	-	10
POLYMER COATED CORRUGATED STEEL DOUBLE WALL	4.0	9.0	750	-	10

NOTES:

- ALLOWABLE TYPES OF PIPES FOR A SPECIFIC AREA ARE TO CONFORM TO THE CRITERIA SHOWN IN TABLES A, A1, B, AND C. ANY DEVIATION MUST BE APPROVED BY THE STATE LOCATION AND DESIGN ENGINEER AND THE DISTRICT MATERIALS ENGINEER.
- SEE HEIGHT OF COVER TABLES FOR MINIMUM AND MAXIMUM COVER LIMITATIONS FOR EACH TYPE OF PIPE.
- SEE TABLE C FOR MINIMUM AND MAXIMUM pH, RESISTIVITY, AND VELOCITY LIMITATIONS FOR METAL PIPES. SEE TABLE D FOR REQUIRED GAUGE OF METAL PIPE.
- ALLOWABLE WATER VELOCITY IN PIPE WHERE ABRASIVE BEDLOAD IS PRESENT OR ANTICIPATED. MAXIMUM VELOCITY BASED ON 10 YEAR DESIGN DISCHARGE (Q).
- pH VALUES APPLY TO BOTH THE IN-SITU SOIL AND WATER. THE LESSER OF THE TWO VALUES SHALL APPLY.
- ph OF SOIL - AASHTO T289.
ph OF WATER - ASTM 1293-12 METHOD A
RESISTIVITY (MINIMUM) OF SOIL - AASHTO T288
- LARGE CULVERTS SHALL BE DESIGNED BY AN ENGINEER, REGISTERED IN THE COMMONWEALTH OF VIRGINIA, AND SHALL BE DESIGNED IN ACCORDANCE WITH THE REQUIREMENTS OF VOLUME V, PART 2 OF THE MANUAL OF THE STRUCTURE AND BRIDGE DIVISION. A LARGE CULVERT IS ANY CULVERT THAT WILL BECOME PART OF THE STRUCTURE AND BRIDGE INVENTORY. THE GEOMETRIC DEFINITION OF THESE STRUCTURES IS PROVIDED IN THE CURRENT VERSION OF VDOT'S IIM-S&B-27.

TABLE D - REQUIRED METAL GAUGE THICKNESS (AFTER ABRASION CONSIDERATIONS)

TABLE D FOR GALVANIZED STEEL 50-YEAR DESIGN LIFE								
	MINIMUM IN -SITU SOIL RESISTIVITY							
pH *	2000	3000	4000	5000	6000	7000	8000	>9000
6	10	12	12	12	12	12	14	14
6.5	12	12	12	14	14	14	14	16
6.8	12	14	14	14	16	16	16	16
7	14	14	16	16	16	16	16	16
7.1	14	16	16	16	16	16	16	16
≥ 7.2	16	16	16	16	16	16	16	16

TABLE D FOR GALVANIZED STEEL 75-YEAR DESIGN LIFE					
	MINIMUM IN -SITU SOIL RESISTIVITY				
pH *	2000	3000	4000-5000	6000-8000	>9000
6	8	8	10	10	12
6.5	8	10	10	12	12
6.8	10	10	12	12	12
7	10	12	12	12	12
7.1	12	12	12	12	12
≥7.2	12	12	12	12	12

TABLE D FOR ALUMINUM COATED TYPE 2, ALUMINUM ALLOY, AND POLYMER -COATED STEEL 50-YEAR DESIGN LIFE											
	MINIMUM IN -SITU SOIL RESISTIVITY										
pH *	1500	2000	3000	4000	5000	6000	7000	8000	9000	10000	>20000
4	10	10	12	12	12	12	14	14	14	14	16
5	12	12	12	14	14	14	14	16	16	16	16
5.5	12	12	14	14	14	16	16	16	16	16	16
6	12	12	14	14	14	16	16	16	16	16	16
6.5	14	14	14	16	16	16	16	16	16	16	16
6.8	14	14	16	16	16	16	16	16	16	16	16
≥7	16	16	16	16	16	16	16	16	16	16	16

TABLE D FOR ALUMINUM COATED TYPE 2, ALUMINUM ALLOY, AND POLYMER -COATED STEEL 75-YEAR DESIGN LIFE															
	MINIMUM IN -SITU SOIL RESISTIVITY														
pH *	1500	2000	3000	4000	5000	6000	7000	8000	9000	10000	20000	30000	40000	50000	>50000
4	N/A	N/A	8	10	10	10	10	12	12	12	12	12	14	14	14
5	8	8	10	10	12	12	12	12	12	12	12	14	14	14	14
5.5	8	10	12	12	12	12	12	12	12	12	14	14	14	16	16
6	10	10	12	12	12	12	12	12	12	12	14	14	16	16	16
6.5	12	12	12	12	12	12	12	14	14	14	16	16	16	16	16
6.8	12	12	12	12	14	14	14	14	14	14	16	16	16	16	16
7	12	12	14	14	14	14	14	16	16	16	16	16	16	16	16
7.1	12	12	14	14	16	16	16	16	16	16	16	16	16	16	16
7.2	14	14	14	16	16	16	16	16	16	16	16	16	16	16	16
7.3	16	16	16	16	16	16	16	16	16	16	16	16	16	16	16
> 7.3	16	16	16	16	16	16	16	16	16	16	16	16	16	16	16

NOTES:

1. LEVEL 3 ABRASION IS MAXIMUM FOR POLYMER COATED STEEL PIPE AND GALVANIZED STEEL PLATE WITH THICKENED INVERT.
2. LEVEL 2 ABRASION IS MAXIMUM FOR REST OF METAL PIPES.
3. PIPES THAT MEET THE CRITERIA OF TABLES A, B, AND C MAY NOT MEET THE CONSIDERATION OF PARTICLE SIZE OF THE BEDLOAD AS DESCRIBED IN THE FHWA ABRASION REQUIREMENTS.
4. BASED ON pH AND RESISTIVITY REQUIREMENTS THE GAUGE OF PIPE MAY NEED TO BE INCREASED AS NOTED IN THESE TABLES TO ATTAIN THE REQUIRED DESIGN LIFE.

* MINIMUM AND MAXIMUM pH FOR EACH PIPE TYPE IS LISTED IN TABLE C

ABRASION LEVEL DEFINITIONS (FHWA)
LEVEL 1 - NONABRASIVE CONDITIONS, AREAS OF NO BEDLOAD AND VERY LOW VELOCITIES. THIS IS THE CONDITION ASSUMED FROM THE SOIL SIDE OF DRAINAGE PIPES
LEVEL 2 - LOW ABRASIVE CONDITIONS, AREAS OF MINOR BEDLOADS AND VELOCITIES OF 5 ft/s OR LESS.
LEVEL 3 - MODERATE ABRASIVE CONDITIONS, AREAS OF MODERATE BEDLOADS OF SAND AND GRAVEL AND VELOCITIES BETWEEN 5 ft/s AND 15 ft/s.
LEVEL 4 - SEVERE ABRASIVE CONDITIONS, AREAS OF HEAVY BEDLOADS OF SAND, GRAVEL, AND ROCK AND VELOCITIES EXCEEDING 15 ft/s.

SPECIFICATION REFERENCE

232
302

A COPY OF THE ORIGINAL SEALED AND SIGNED STANDARD DRAWING IS ON FILE IN THE CENTRAL OFFICE

ALLOWABLE PIPE CRITERIA FOR CULVERT AND STORM SEWERS

VIRGINIA DEPARTMENT OF TRANSPORTATION



ROAD AND BRIDGE STANDARDS

REVISION DATE

11/15

SHEET 18 OF 18

107.22

8"X8" OPENING FOR BACKFILL INSTALLATION AT BOTH ENDS OF BOX CULVERT

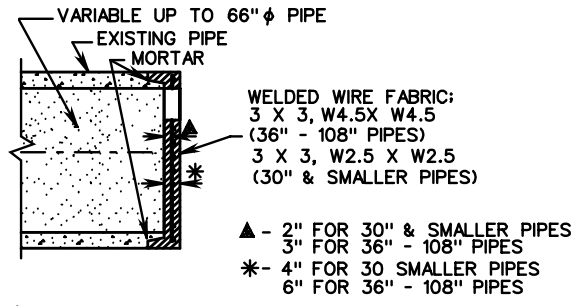
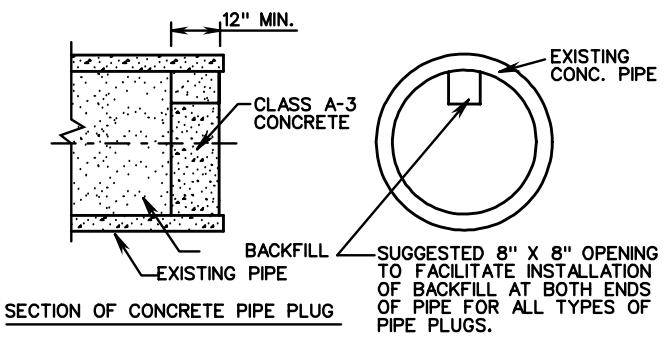
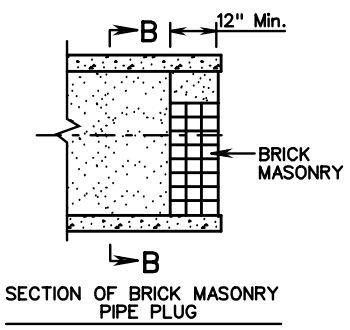
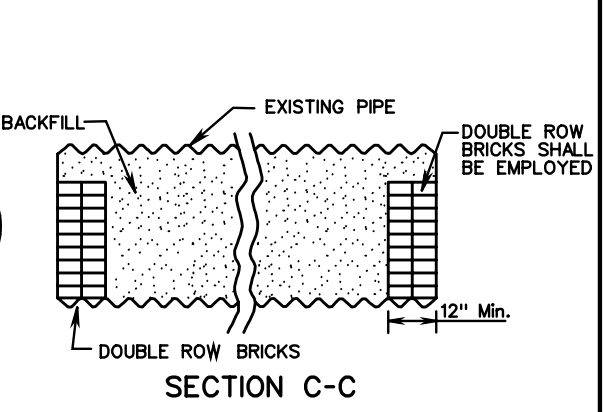
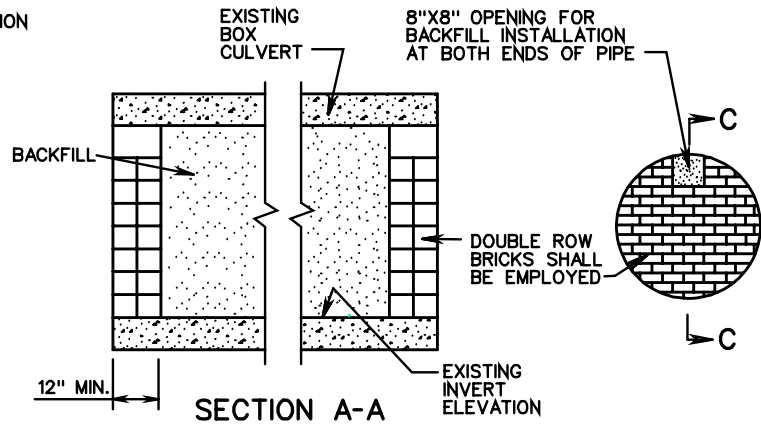
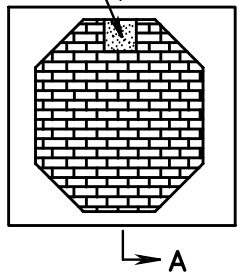

SECTION OF BRICK MASONRY PIPE PLUG

SECTION B-B

SECTION OF PRECAST PIPE PLUG (Male End)
(MALE OR FEMALE PLUG DESIGN)
TO BE FURNISHED WHERE APPLICABLE.

NOTES:

BACKFILL IS TO BE EITHER FLOWABLE BACKFILL OR FINE AGGREGATE AS PER THE SPECIFICATIONS AND IS TO BE PAID AS CUBIC YARDS OF FLOWABLE BACKFILL.

FOR PLACEMENT OF STRUCTURES, SEE ROADWAY PLAN SHEETS.

CONCRETE BRICK MAY BE USED IN LIEU OF CLAY BRICK. JUMBO BRICK WILL BE PERMITTED.

PRECAST NOTES :

CONCRETE TO BE 4000 P. S. I. MIN. COMPRESSIVE STRENGTH.

CONCRETE AND REINFORCING STEEL SHALL BE IN ACCORDANCE WITH AASHTO M170.

DETAIL SHOWN FOR PRECAST PLUG IS REPRESENTATIVE ONLY, OTHER MANUFACTURER'S DESIGN WILL BE ACCEPTABLE UPON APPROVAL BY THE ENGINEER.

QUANTITIES		
PIPE SIZE	CU.YDS BACKFILL PER LINEAR FOOT	CU.YDS PER EACH CONC. PLUG
12"	0.029	.013
15"	0.045	.029
18"	0.065	.049
24"	0.116	.100
30"	0.182	.166
36"	0.262	.246
42"	0.356	.340
48"	0.465	.449
54"	0.589	.573
60"	0.727	.711
66"	0.880	.864
72"	1.047	1.031
78"	1.229	1.213
84"	1.425	1.409
90"	1.636	1.620
96"	1.862	1.846
102"	2.102	2.086
108"	2.356	2.340

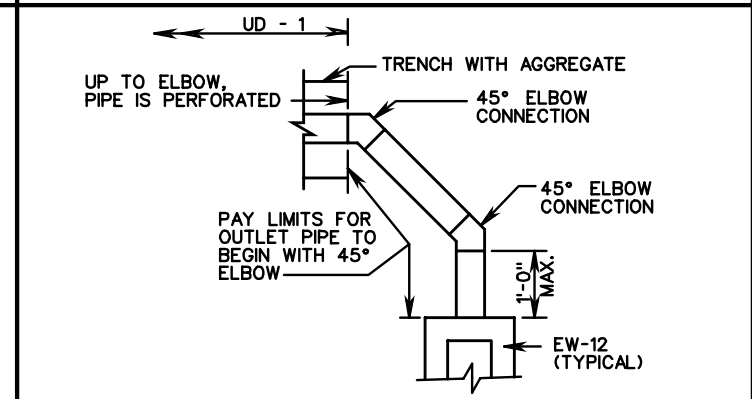
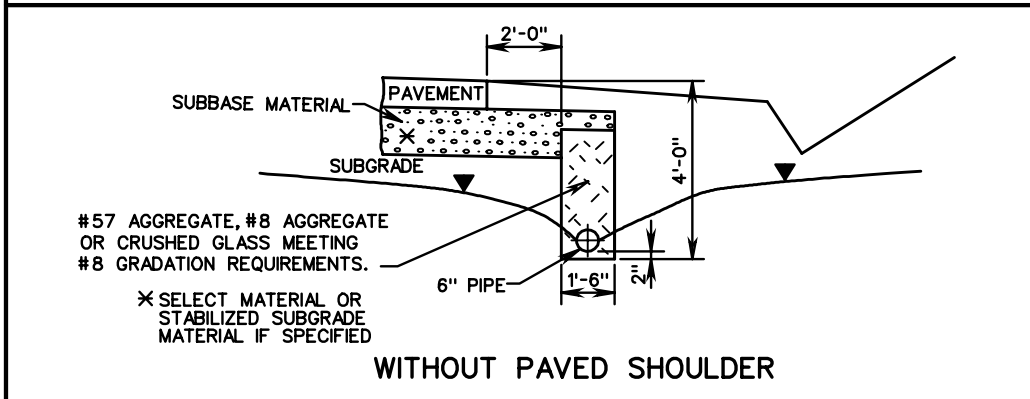
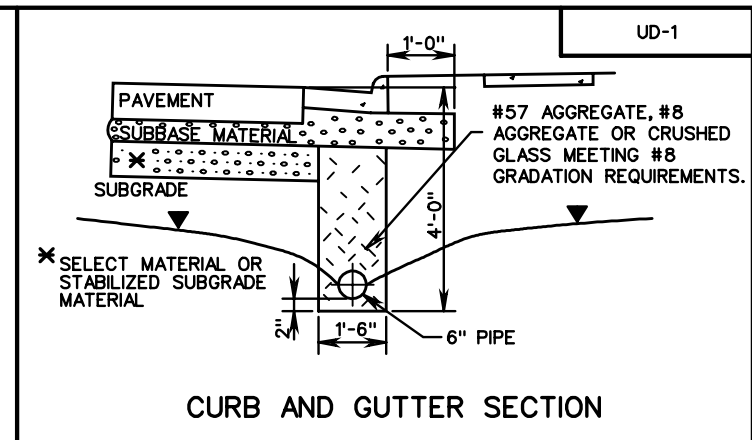
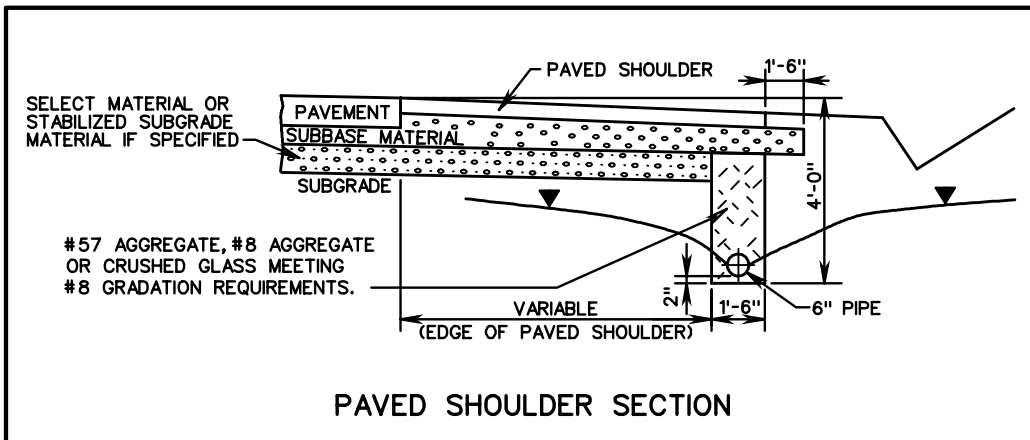

LONGITUDINAL PERFORATED PIPE

TYPE OF PIPE	CRUSHING STRENGTH	
	W.T.	6" NOMINAL DIAMETER
SMOOTH WALL PVC	.153	
CORRUGATED PE		AASHTO M-252

NON-PERFORATED OUTLET PIPE

TYPE OF PIPE	CRUSHING STRENGTH	
	W.T.	6" NOMINAL DIAMETER
SMOOTH WALL PVC	.153	
SMOOTH WALL PE		70 PSI ***

WALL THICKNESS (MIN) - INCHES
 *** TESTED ACCORDING TO ASTM D-2412 AT 5% DEFLECTION.

NOTES:

1. WHEN THE LONGITUDINAL PIPE CONNECTS DIRECTLY INTO A DRAINAGE STRUCTURE (DROP INLET, MANHOLE, ECT.), NON-PERFORATED OUTLET PIPES ARE NOT REQUIRED.
2. INVERT ELEVATION AT OUTLET END OF OUTLET PIPE TO BE A MINIMUM OF 1'-0" ABOVE INVERT ELEVATION OF RECEIVING DRAINAGE DITCH OR STRUCTURE.
3. ALL CONNECTIONS (ELBOWS, WYES, ETC.) WITHIN PAY LIMITS FOR OUTLET PIPE ARE TO BE OF THE SAME CRUSHING STRENGTH AS THE OUTLET PIPE.
4. OUTLET PIPE ARE TO BE INSTALLED ON 2% MIN. (3% DESIRABLE) GRADE.
5. THE NORMAL DEPTH OF UNDERDRAIN IS TO BE 4'-0" BELOW THE NEAR EDGE OF PAVEMENT AS SHOWN. THE LONGITUDINAL GRADE OF THE UNDERDRAIN SHALL FOLLOW THAT OF THE ROADWAY WITH A MINIMUM GRADE OF 0.2%.
6. WHERE THE BOTTOM OF SELECT MATERIAL IS GREATER THAN 4'-0" BELOW THE PAVEMENT, THE BOTTOM OF THE UNDERDRAIN IS TO BE COINCIDENT WITH THE BOTTOM OF SELECT MATERIAL AND THE TRENCH DEPTH AND BACKFILL QUANTITY INCREASED ACCORDINGLY.
7. WHEN USED WITH STABILIZED OPEN-GRADED DRAINAGE LAYER, THE BOTTOM OF THE CURB AND GUTTER SHALL BE CONSTRUCTED PARALLEL TO THE SLOPE OF SUBBASE COURSES OUT TO THE DEPTH OF THE PAVEMENT.
8. OUTLET PIPE TO BE SECURELY CONNECTED TO EW-12 OR OTHER DRAINAGE STRUCTURE.
9. ▼ DENOTES WATER TABLE.
10. OUTLET PIPE CONFIGURATION TO PROVIDE FOR PASSAGE OF INSPECTION CAMERA WITH 2 1/2" I. D. HEAD.

SPECIFICATION REFERENCE
240
501
701

STANDARD GROUNDWATER UNDERDRAIN

VIRGINIA DEPARTMENT OF TRANSPORTATION

VDOT ROAD AND BRIDGE STANDARDS	
REVISION DATE	SHEET 1 OF 1
108.01	

LONGITUDINAL PERFORATED PIPE

TYPE OF PIPE	CRUSHING STRENGTH	
	× W.T.	6" NOMINAL DIAMETER
SMOOTH WALL PVC	0.153	
CORRUGATED PE		AASHTO M-252

NON-PERFORATED OUTLET PIPE

TYPE OF PIPE	CRUSHING STRENGTH	
	× W.T.	6" NOMINAL DIAMETER
SMOOTH WALL PVC	0.153	
SMOOTH WALL PE		70 PSI ×××

× WALL THICKNESS (MIN) - INCHES
 ××× TESTED ACCORDING TO ASTM D-2412 AT 5% DEFLECTION.

NOTES:

1. WHEN THE LONGITUDINAL PIPE CONNECTS DIRECTLY INTO A DRAINAGE STRUCTURE (DROP INLET, MANHOLE, ECT.), NON-PERFORATED OUTLET PIPES ARE NOT REQUIRED.
2. INVERT ELEVATION AT OUTLET END OF OUTLET PIPE TO BE A MINIMUM OF 1'-0" ABOVE INVERT ELEVATION OF RECEIVING DRAINAGE DITCH OR STRUCTURE.
3. ALL CONNECTIONS (ELBOWS, WYES, ETC.) WITHIN PAY LIMITS FOR OUTLET PIPE ARE TO BE OF THE SAME CRUSHING STRENGTH AS THE OUTLET PIPE.
4. OUTLET PIPE ARE TO BE INSTALLED ON 2% MIN. (3% DESIRABLE) GRADE AND LOCATED AT A MAXIMUM OF 500' APART.
5. OUTLET PIPE TO BE SECURELY CONNECTED TO EW-12OR OTHER DRAINAGE STRUCTURE.
6. WHEN UNDERDRAIN MUST TRAVERSE UNDER CROSSOVER LOCATIONS, NON-PERFORATED OUTLET PIPE ONLY IS TO BE USED UNDER CROSSOVER PAVEMENT.

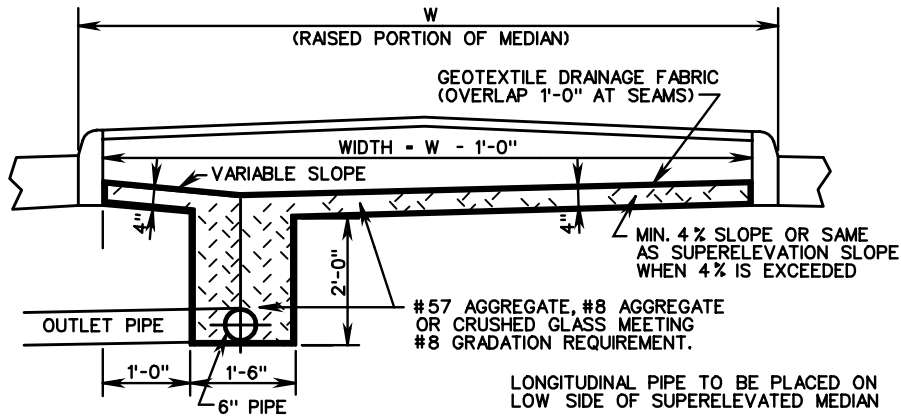

WITHOUT SUBBASE MATERIAL

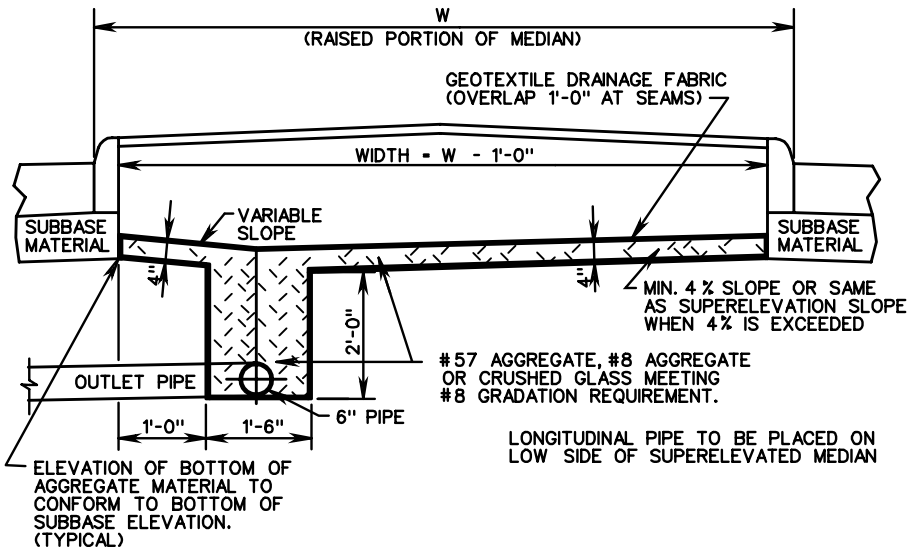

WITH SUBBASE MATERIAL

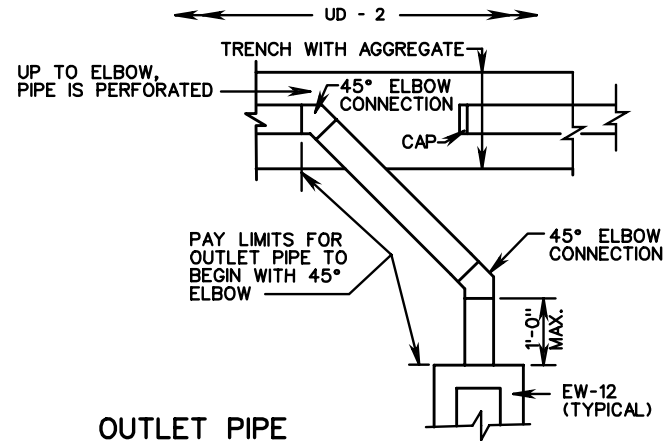

OUTLET PIPE



ROAD AND BRIDGE STANDARDS

SHEET 1 OF 1

REVISION DATE

108.02

STANDARD UNDERDRAIN FOR USE WITH RAISED GRASS MEDIAN STRIPS

VIRGINIA DEPARTMENT OF TRANSPORTATION

SPECIFICATION REFERENCE

240
501
701

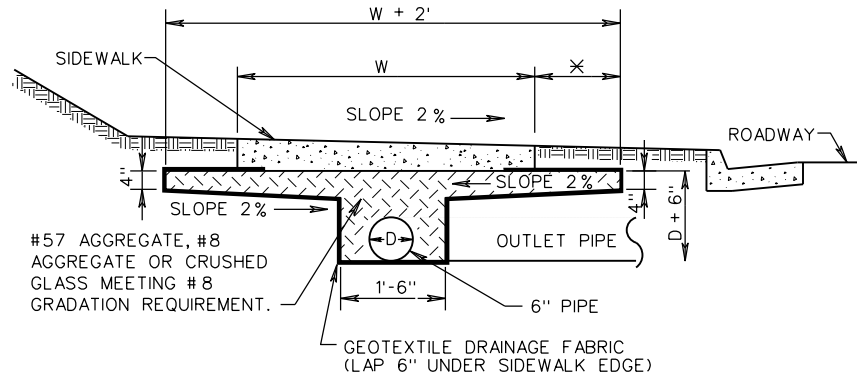

#57 AGGREGATE, #8 AGGREGATE OR CRUSHED GLASS MEETING #8 GRADATION REQUIREMENT.

GEOTEXTILE DRAINAGE FABRIC (LAP 6" UNDER SIDEWALK EDGE)

* THIS PORTION TO BE DELETED WHEN SIDEWALK IS ADJACENT TO CURB OR CURB AND GUTTER WITH NO BUFFER STRIP.

NOTES:

1. WHEN THE LONGITUDINAL PIPE CONNECTS DIRECTLY INTO A DRAINAGE STRUCTURE (DROP INLET, MANHOLE, ECT.), NON-PERFORATED OUTLET PIPES ARE NOT REQUIRED.
2. INVERT ELEVATION AT OUTLET END OF OUTLET PIPE TO BE A MINIMUM OF 1'-0" ABOVE INVERT ELEVATION OF RECEIVING DRAINAGE DITCH OR STRUCTURE.
3. ALL CONNECTIONS (ELBOWS, WYES, ETC.) WITHIN PAY LIMITS FOR OUTLET PIPE ARE TO BE OF THE SAME CRUSHING STRENGTH AS THE OUTLET PIPE.
4. OUTLET PIPE ARE TO BE INSTALLED ON 2% MIN. (3% DESIRABLE) GRADE.
5. OUTLET PIPE TO BE SECURELY CONNECTED TO EW-12 OR OTHER DRAINAGE STRUCTURE.
6. SIDEWALK UNDERDRAIN IS TO BE USED WHEN THE SIDEWALK LONGITUDINAL GRADIENT IS 3% OR MORE AND WHEN THE UNDERLYING SOIL HAS 34% OR MORE PASSING THE NO. 200 SIEVE, AND HAS A P10F 13 OR LESS, AND THE AREA HAS A HISTORY OF SIDEWALK UNDERMINING.
7. SIDEWALK UNDERDRAINS SHOULD BE TIED INTO THE STORM SEWER SYSTEM AT POINTS APPROXIMATELY A CITY BLOCK APART. UNDERDRAIN RUNS MUST NOT EXCEED 1,000 FEET IN LENGTH WITHOUT DISCHARGING INTO THE STORM DRAIN SYSTEM OR INTO AN OPEN DRAIN.
8. WITHIN THE LIMITS OF A COMMERCIAL ENTRANCE, NON-PERFORATED PIPE SHALL BE UTILIZED IN LIEU OF PERFORATED PIPE.

LONGITUDINAL PERFORATED PIPE

TYPE OF PIPE	CRUSHING STRENGTH	
	* W.T.	6" NOMINAL DIAMETER
SMOOTH WALL PVC	0.153	
CORRUGATED PE		AASHTO M-252

NON-PERFORATED PIPE FOR USE UNDER COMMERCIAL ENTRANCES AND FOR OUTLETS

TYPE OF PIPE	CRUSHING STRENGTH	
	* W.T.	6" NOMINAL DIAMETER
SMOOTH WALL PVC	0.153	
SMOOTH WALL PE		70 PSI ***

* WALL THICKNESS (MIN) - INCHES
 *** TESTED ACCORDING TO ASTM D-2412 AT 5% DEFLECTION.

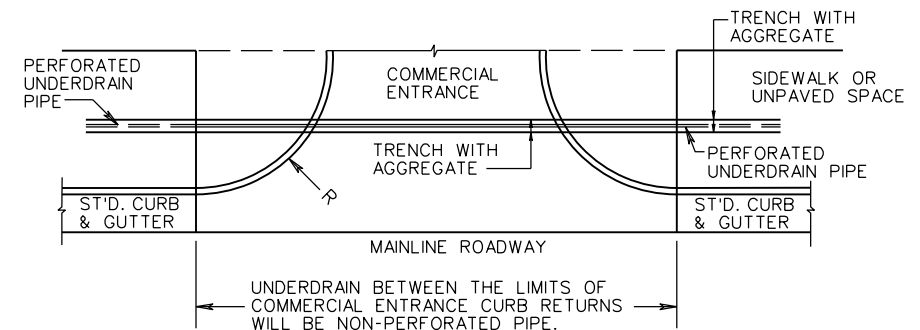
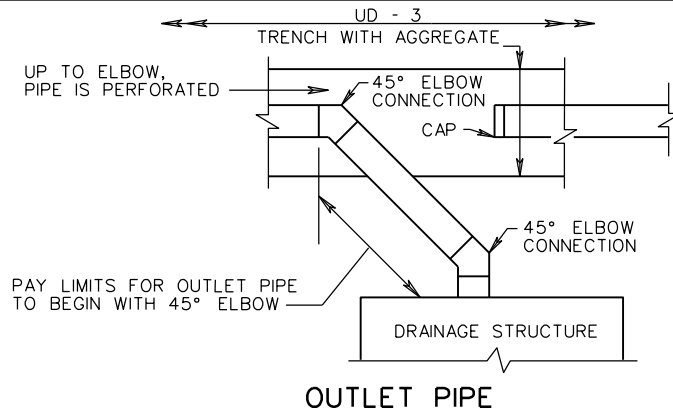

SPECIFICATION REFERENCE

STANDARD SIDEWALK UNDERDRAIN

VIRGINIA DEPARTMENT OF TRANSPORTATION



ROAD AND BRIDGE STANDARDS

REVISION DATE

SHEET 1 OF 1

108.03

CD-1

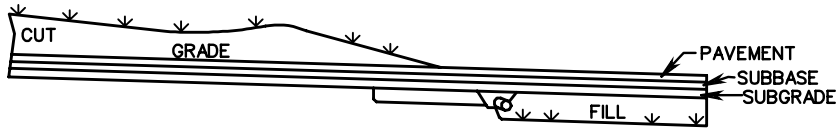

**COMBINATION UNDERDRAIN CD-1 AT LOWER END OF CUTS
CENTER LINE SECTION
(WITH TYPE I SELECT MATERIAL)**

TRENCH PLACEMENT

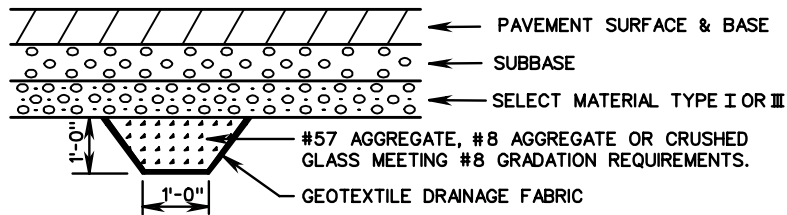

OR

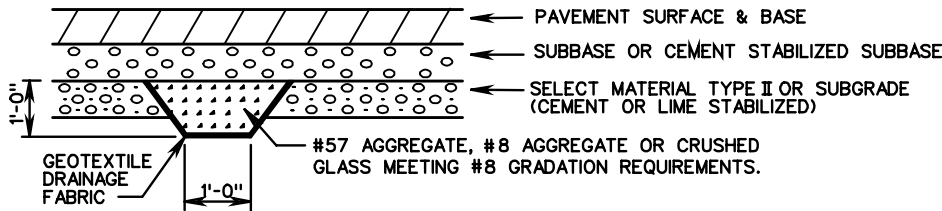

NON-PERFORATED OUTLET PIPE

TYPE OF PIPE	CRUSHING STRENGTH			
	W.T.	4" NOM. DIAMETER	W.T.	6" NOM. DIAMETER
SMOOTH WALL PVC	.103		0.153	
SMOOTH WALL PE		70 PSI ***		70 PSI ***

✕ WALL THICKNESS (MIN) - INCHES
 *** TESTED ACCORDING TO ASTM D-2412 AT 5% DEFLECTION.

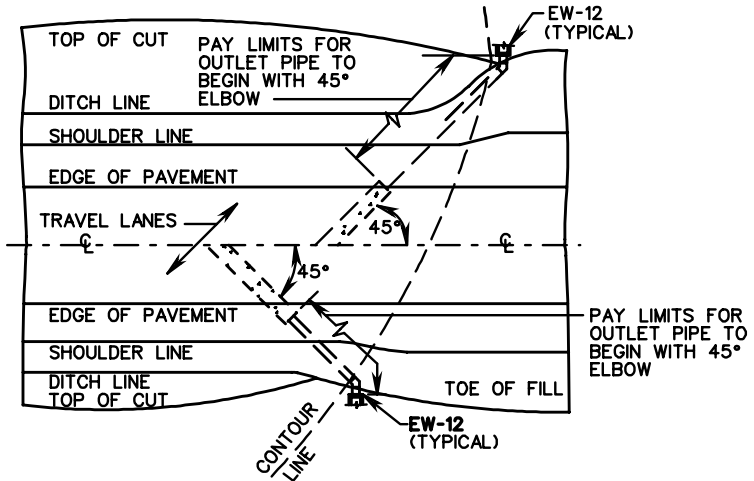

**PLAN VIEW
(PLACEMENT OF CD-1 COMBINATION UNDERDRAIN)**

GENERAL NOTES

- UNLESS SPECIFICALLY INDICATED, COMBINATION UNDERDRAIN WILL NOT BE LOCATED AT THIS POINT WHEN BOTH SUBBASE AND SUBGRADE ARE STABILIZED.
- TRENCH SHALL BE FILLED WITH AGGREGATE AND THOROUGHLY HAND TAMPED TO INSURE COMPACTNESS.
- OUTLET PIPE SHALL BEGIN AT THE EDGE OF THE TRAVEL LANE PAVEMENT AND SHALL BE PLACED ON A GRADE PARALLEL TO THE SHOULDER SLOPE 2% MIN. (3% DESIRABLE) GRADE.
- ON CURB AND GUTTER SECTIONS, WHERE IT IS IMPOSSIBLE TO OTHERWISE PROVIDE OUTLETS FOR UNDERDRAINS, THEY ARE TO BE LOCATED SO AS TO DRAIN INTO DROP INLETS OR MANHOLES.
- ON SUPERELEVATED SECTIONS, TRENCH IS TO BE UNDER ENTIRE PAVEMENT AREA WITH OUTLET PIPE ON LOW SIDE ONLY.
- INVERT ELEVATION AT OUTLET END OF OUTLET PIPE TO BE A MINIMUM OF 1'-0" ABOVE INVERT ELEVATION OF RECEIVING DRAINAGE DITCH OR STRUCTURE.
- ALL CONNECTIONS (ELBOWS, WYES, ETC.) WITHIN PAY LIMITS FOR OUTLET PIPE ARE TO BE OF THE SAME CRUSHING STRENGTH AS THE OUTLET PIPE.
- OUTLET PIPE TO BE SECURELY CONNECTED TO EW-12 OR OTHER DRAINAGE STRUCTURE.



ROAD AND BRIDGE STANDARDS

SHEET 1 OF 1

REVISION DATE

108.04

STANDARD COMBINATION UNDERDRAIN

(AT LOWER END OF CUTS)

VIRGINIA DEPARTMENT OF TRANSPORTATION

SPECIFICATION REFERENCE

232
501
701

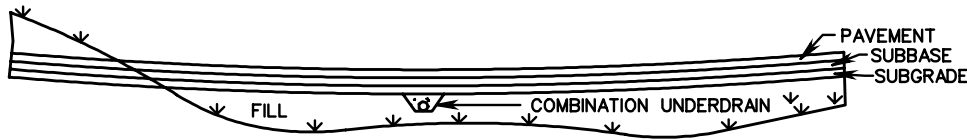

**COMBINATION UNDERDRAIN CD-2 ON FILLS
CENTER LINE SECTION
(WITH TYPE I SELECT MATERIAL)**

TRENCH PLACEMENT

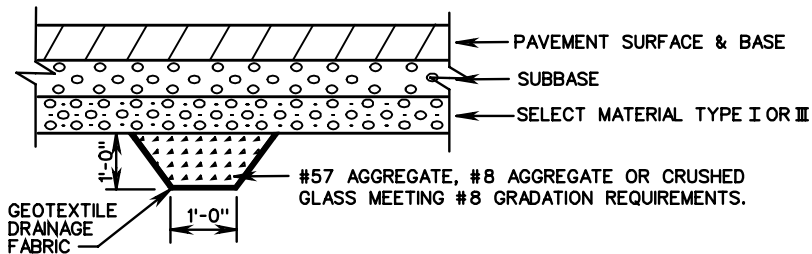

OR

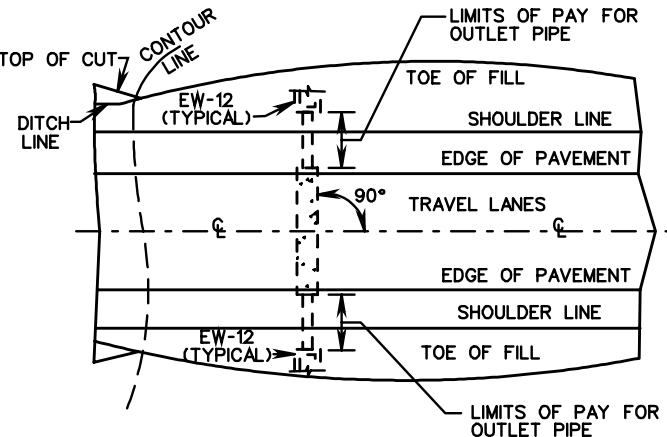
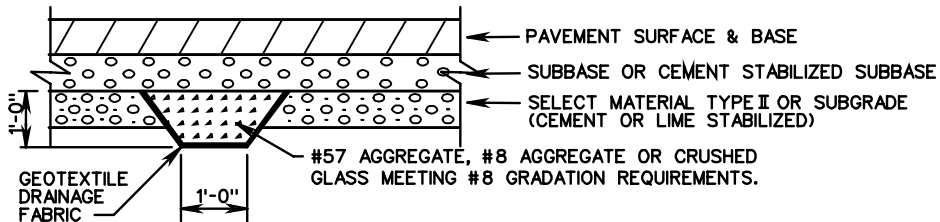

**PLAN VIEW SHOWING PLACEMENT OF
CD-2 UNDERDRAIN**

NON-PERFORATED OUTLET PIPE

TYPE OF PIPE	CRUSHING STRENGTH			
	× W.T.	4" NOM. DIAMETER	× W.T.	6" NOM. DIAMETER
SMOOTH WALL PVC	.103		0.163	
SMOOTH WALL PE		70 PSI ×××		70 PSI ×××

× WALL THICKNESS (MIN) - INCHES
××× TESTED ACCORDING TO ASTM D-2412 AT 5% DEFLECTION.

GENERAL NOTES

1. TRENCH SHALL BE FILLED WITH AGGREGATE AND THOROUGHLY HAND TAMPED TO INSURE COMPACTNESS.
2. OUTLET PIPE SHALL BEGIN AT THE EDGE OF THE TRAVEL LANE PAVEMENT AND SHALL BE PLACED ON A GRADE PARALLEL TO THE SHOULDER SLOPE 2% MIN. (.3% DESIRABLE) GRADE.
3. ON CURB AND GUTTER SECTIONS, WHERE IT IS IMPOSSIBLE TO OTHERWISE PROVIDE OUTLETS FOR UNDERDRAINS, THEY ARE TO BE LOCATED SO AS TO DRAIN INTO DROP INLETS OR MANHOLES.
4. ON SUPERELEVATED SECTIONS, TRENCH IS TO BE UNDER ENTIRE PAVEMENT AREA WITH OUTLET PIPE ON LOW SIDE ONLY.
5. INVERT ELEVATION AT OUTLET END OF OUTLET PIPE TO BE A MINIMUM OF 1'-0" ABOVE INVERT ELEVATION OF RECEIVING DRAINAGE DITCH OR STRUCTURE.
6. ALL CONNECTIONS (ELBOWS, WYES, ETC.) WITHIN PAY LIMITS FOR OUTLET PIPE ARE TO BE OF THE SAME CRUSHING STRENGTH AS THE OUTLET PIPE.
7. OUTLET PIPE TO BE SECURELY CONNECTED TO EW-12 OR OTHER DRAINAGE STRUCTURE.

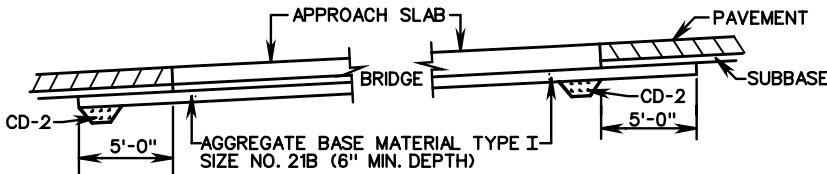

**PLACEMENT OF CD-2 UNDERDRAIN AT
BRIDGE APPROACH SLABS**

SPECIFICATION
REFERENCE

232
501
701

**STANDARD COMBINATION UNDERDRAIN
(AT GRADE SAGS AND BRIDGE APPROACHES)**

VIRGINIA DEPARTMENT OF TRANSPORTATION

VDOT

ROAD AND BRIDGE STANDARDS

REVISION DATE

SHEET 1 OF 1

108.05

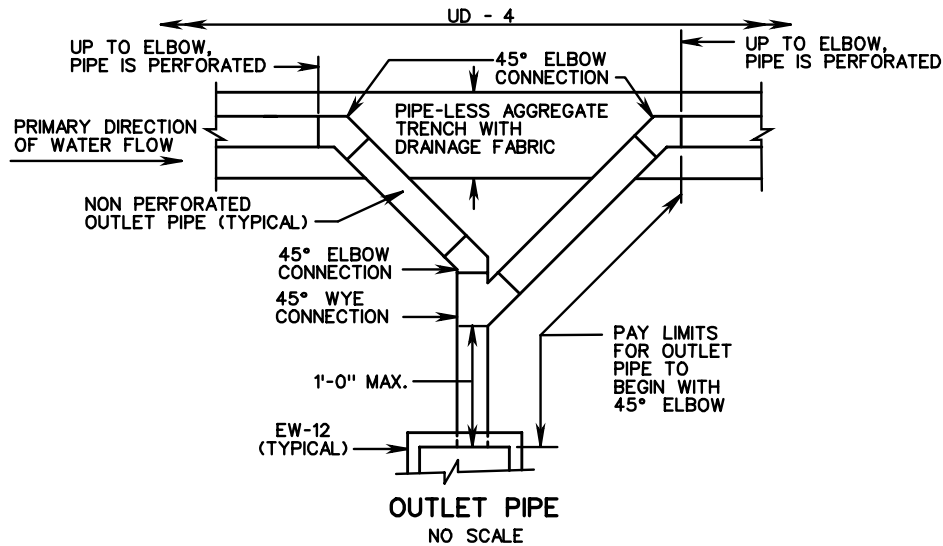
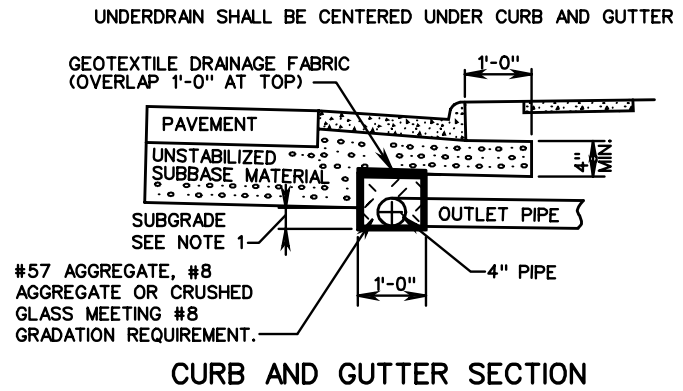
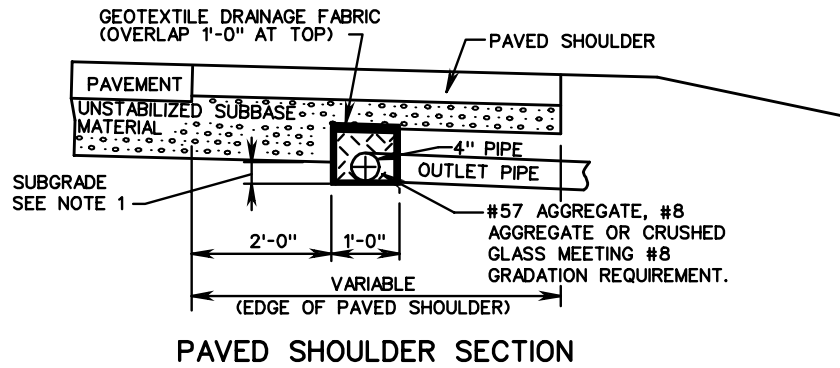

ROAD AND BRIDGE STANDARDS

STANDARD PAVEMENT EDGEDRAIN

SPECIFICATION REFERENCE

SHEET 1 OF 2

REVISION DATE

240
258
501
701

108.06

VIRGINIA DEPARTMENT OF TRANSPORTATION

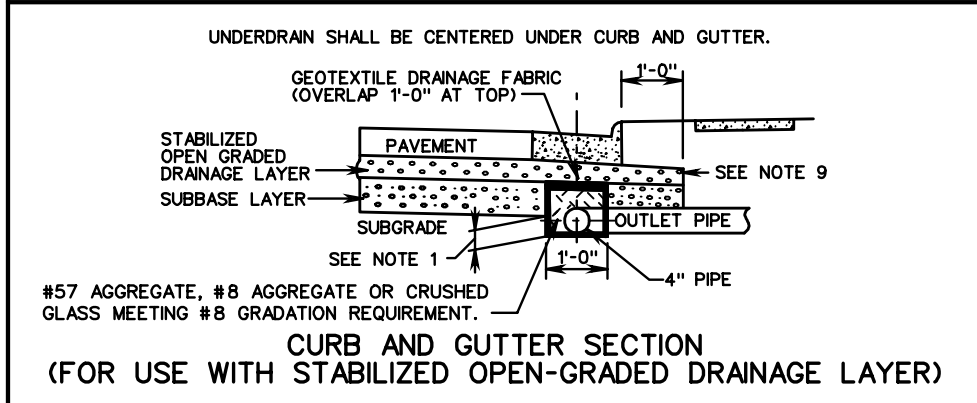
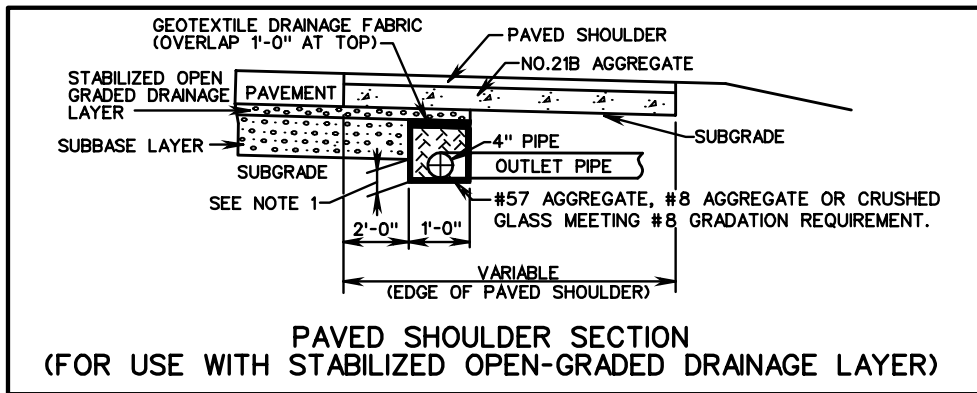

- NOTES:**
1. 4" MINIMUM, PROVIDED ATTAINING MINIMUM 4" OF AGGREGATE ON TOP OF PIPE.
 2. WHEN THE LONGITUDINAL PIPE CONNECTS DIRECTLY INTO A DRAINAGE STRUCTURE (DROP INLET, MANHOLE, ECT.), NON-PERFORATED OUTLET PIPES ARE NOT REQUIRED.
 3. INVERT ELEVATION AT OUTLET END OF OUTLET PIPE TO BE A MINIMUM OF 1'-0" ABOVE INVERT ELEVATION OF RECEIVING DRAINAGE DITCH OR STRUCTURE.
 4. ALL CONNECTIONS (ELBOWS, WYES, ETC.) WITHIN PAY LIMITS FOR OUTLET PIPE ARE TO BE OF THE SAME CRUSHING STRENGTH AS THE OUTLET PIPE.
 5. OUTLET PIPES ARE TO BE INSTALLED ON 2% MIN. (3% DESIRABLE) GRADE AND LOCATED EVERY 350' MAXIMUM OR AS NOTED ON PLANS.
 6. OUTLET PIPE TO BE SECURELY CONNECTED TO EW-12 OR OTHER DRAINAGE STRUCTURE.
 7. WITHIN THE LIMITS OF A COMMERCIAL ENTRANCE, NON-PERFORATED PIPE SHALL BE UTILIZED IN LIEU OF PERFORATED PIPE.
 8. THE LENGTH OF PIPE BETWEEN THE WYE CONNECTION AND THE EW-12 SHALL BE LIMITED TO NO MORE THAN 1'-0" TO PERMIT CAMERA INSPECTION OF THE MAIN LINE IN EITHER DIRECTION.
 9. IN SITUATIONS WHEN FULL DEPTH OF STABILIZED OPEN-GRADED MATERIAL CANNOT BE MAINTAINED UNDER CURB AND GUTTER, NO. 21B AGGREGATE SHALL BE USED UNDER CURB AND GUTTER. NO. 21B AGGREGATE MAY ALSO BE USED FROM TOP OF STABILIZED OPEN-GRADED MATERIAL LAYER AND CURB AND GUTTER.

SPECIFICATION REFERENCE
240
258
501
701

STANDARD PAVEMENT EDGEDRAIN

VIRGINIA DEPARTMENT OF TRANSPORTATION

LONGITUDINAL PERFORATED PIPE

UD-4

TYPE OF PIPE	CRUSHING STRENGTH	
	× W.T.	4" NOM. DIAMETER
SMOOTH WALL PVC	.103	
CORRUGATED PE		AASHTO M-252

NON-PERFORATED OUTLET PIPE FOR USE UNDER COMMERCIAL ENTRANCES AND FOR OUTLETS

TYPE OF PIPE	CRUSHING STRENGTH	
	× W.T.	4" NOM. DIAMETER
SMOOTH WALL PVC	.103	
SMOOTH WALL PE		70 PSI ×××

× WALL THICKNESS (MIN) - INCHES
××× TESTED ACCORDING TO ASTM D-2412 AT 5% DEFLECTION.

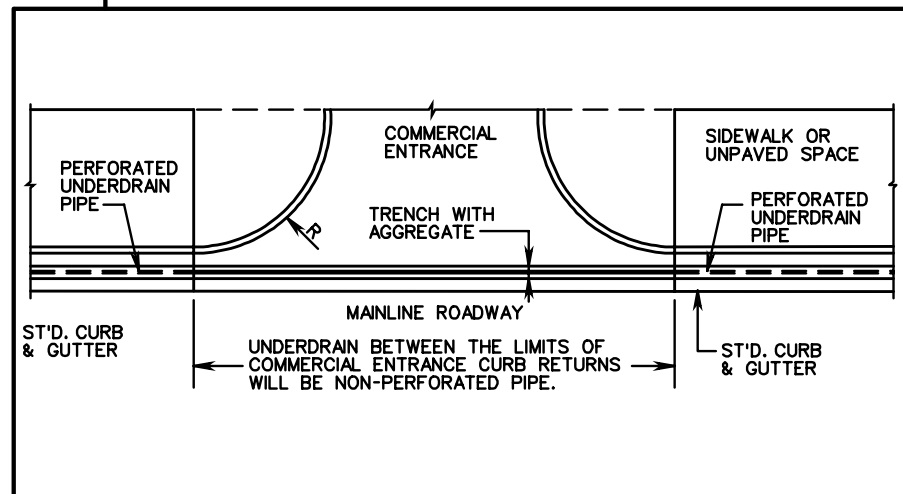
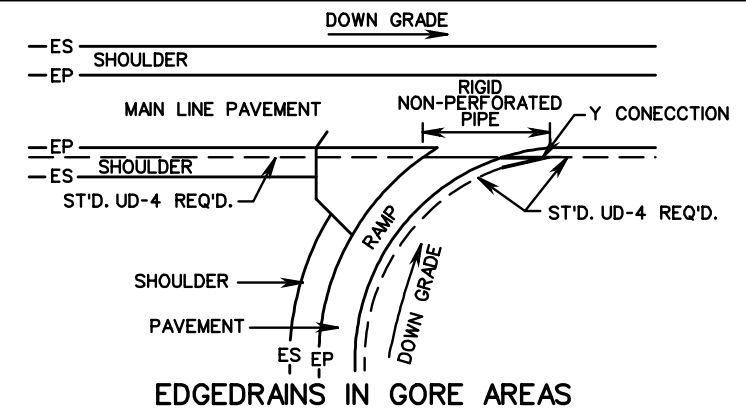

VDOT

ROAD AND BRIDGE STANDARDS

REVISION DATE

SHEET 2 OF 2

108.07

UD-5

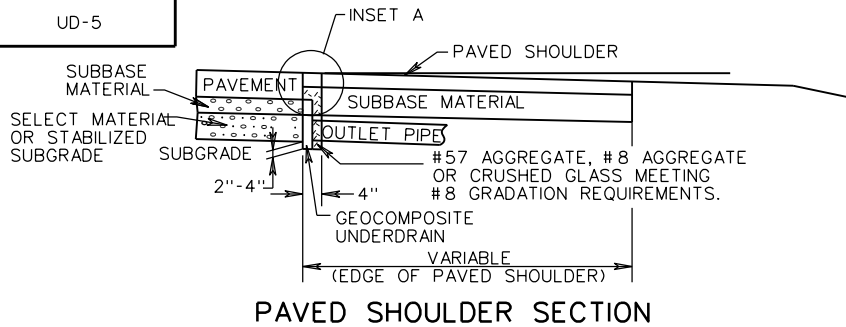

PAVED SHOULDER SECTION

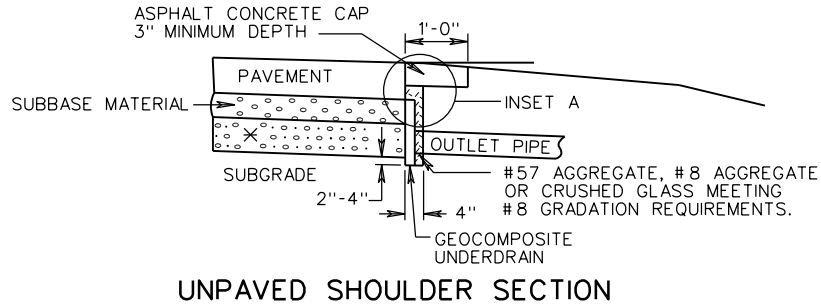
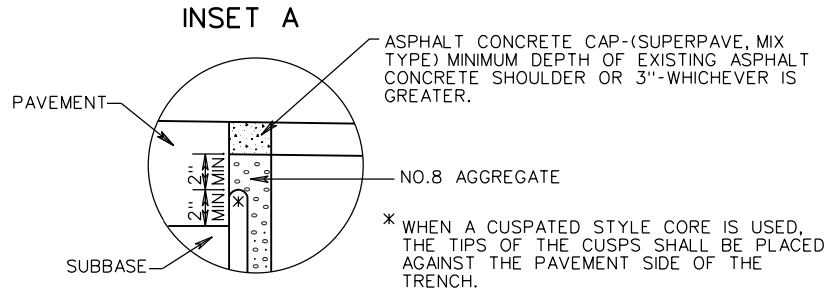

UNPAVED SHOULDER SECTION

* SELECT MATERIAL OR STABILIZED SUBGRADE MATERIAL

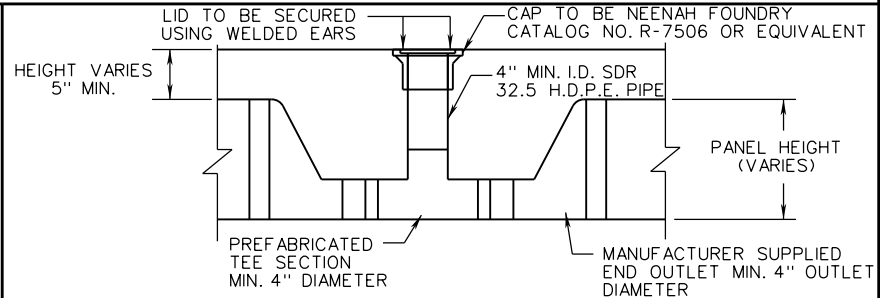

ELEVATION VIEW



PLAN VIEW

UD - 5 INSPECTION PORT

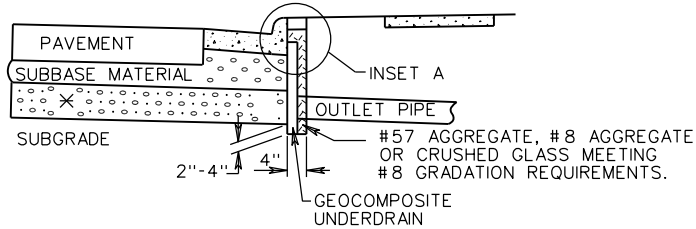

CURB AND GUTTER SECTION

* SELECT MATERIAL OR STABILIZED SUBGRADE MATERIAL

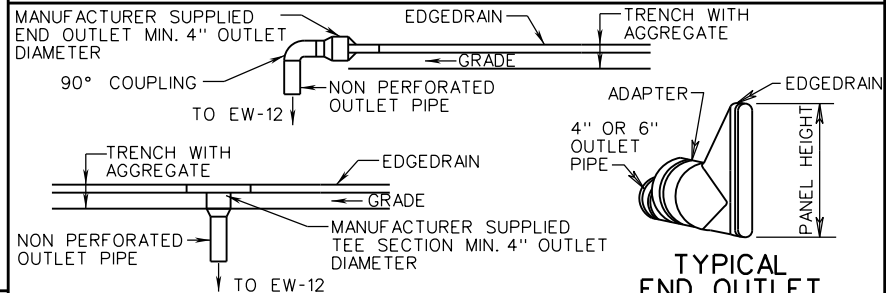

EDGEDRAIN CONNECTION TO OUTLET PIPE

NON-PERFORATED OUTLET PIPE

TYPE OF PIPE	CRUSHING STRENGTH	
	*W.T. 4" NOM. DIAMETER	*W.T. 6" NOM. DIAMETER
CORRUGATED ALUMINUM		0.048
SMOOTH WALL PVC	.103	0.153
SMOOTH WALL PE	70 PSI ***	70 PSI ***

* WALL THICKNESS (MIN) - INCHES
*** TESTED ACCORDING TO ASTM D-2412 AT 5% DEFLECTION.

NOTES:

1. INVERT ELEVATION AT OUTLET END OF OUTLET PIPE TO BE A MINIMUM OF 1'-0" ABOVE INVERT ELEVATION OF RECEIVING DRAINAGE DITCH OR STRUCTURE.
2. ALL CONNECTIONS (ELBOWS, WYES, ETC.) WITHIN PAY LIMITS FOR OUTLET PIPE SHALL BE OF THE SAME CRUSHING STRENGTH AS THE OUTLET PIPE.
3. OUTLET PIPES SHALL BE INSTALLED ON 2% MIN. (3% DESIRABLE) GRADE AND LOCATED EVERY 350' MAXIMUM OR AS NOTED ON PLANS.
4. OUTLET PIPE TO BE SECURELY CONNECTED TO EW-12 OR OTHER DRAINAGE STRUCTURE.
5. UD-5 INSPECTION PORTS SHALL BE LOCATED WHERE SPECIFIED ON THE PLANS.



ROAD AND BRIDGE STANDARDS

SHEET 1 OF 1

REVISION DATE

108.08

01/15

A COPY OF THE ORIGINAL SEALED AND SIGNED DRAWING IS ON FILE IN THE CENTRAL OFFICE.
**PREFABRICATED GEOCOMPOSITE RETROFIT
PAVEMENT EDGEDRAIN**
VIRGINIA DEPARTMENT OF TRANSPORTATION

SPECIFICATION REFERENCE

240
501
701

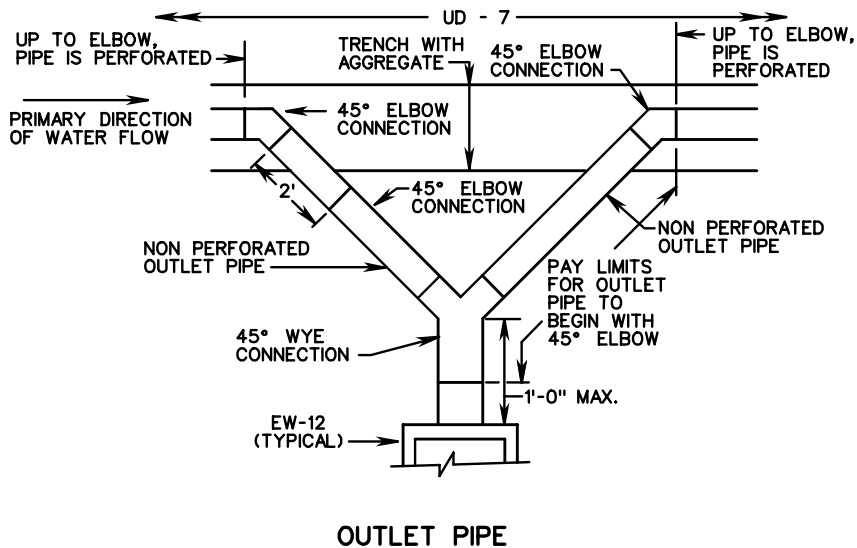
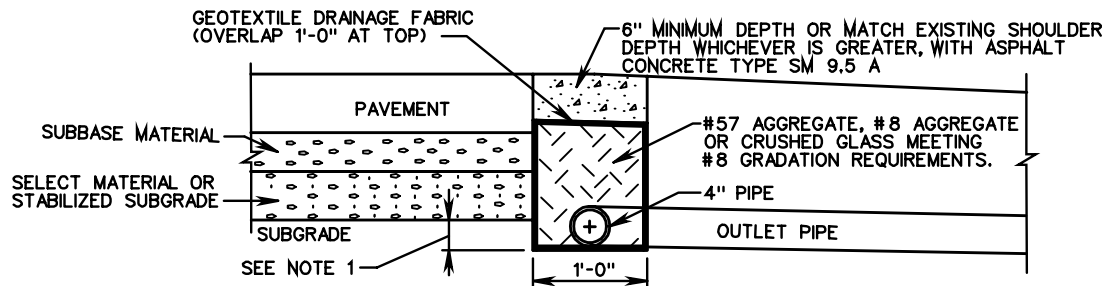

NOTES:

1. 4" MINIMUM, PROVIDED ATTAINING MINIMUM 4" OF AGGREGATE ON TOP OF PIPE.
2. WHERE THE LONGITUDINAL PERFORATED PIPE ALIGNS WITH A DRAINAGE STRUCTURE (DROP INLET, MANHOLE, ETC.), A NON-PERFORATED OUTLET PIPE IS NOT REQUIRED. INSTEAD, THE PERFORATED PIPE IS TO BE CONNECTED DIRECTLY TO THE DRAINAGE STRUCTURE. WHERE THE LONGITUDINAL PERFORATED PIPE IS CONTINUOUS, IT SHALL BE CONNECTED TO EACH SIDE OF THE DRAINAGE STRUCTURE.
3. INVERT ELEVATION AT OUTLET END OF OUTLET PIPE TO BE A MINIMUM OF 1'-0" ABOVE INVERT ELEVATION OF RECEIVING DRAINAGE DITCH OR STRUCTURE.
4. ALL CONNECTIONS (ELBOWS, WYES, ETC.) WITHIN PAY LIMITS FOR OUTLET PIPE ARE TO BE OF THE SAME CRUSHING STRENGTH AS THE OUTLET PIPE.
5. OUTLET PIPES ARE TO BE INSTALLED ON 2% MIN. (3% DESIRABLE) GRADE AND LOCATED EVERY 350' MAXIMUM OR AS NOTED ON PLANS.
6. OUTLET PIPE TO BE SECURELY CONNECTED TO EW-12 OR OTHER DRAINAGE STRUCTURE.
7. WITHIN THE LIMITS OF A COMMERCIAL ENTRANCE, NON-PERFORATED PIPE SHALL BE UTILIZED IN LIEU OF PERFORATED PIPE.
8. THE LENGTH OF PIPE BETWEEN THE WYE CONNECTION AND THE EW-12 SHALL BE LIMITED TO NO MORE THAN 1'-0" TO PERMIT CAMERA INSPECTION OF THE MAIN LINE IN EITHER DIRECTION.
9. EXISTING ASPHALT SHOULDER TO BE SAWED TO ACHIEVE A SMOOTH JOINT.

LONGITUDINAL PERFORATED PIPE

TYPE OF PIPE	CRUSHING STRENGTH	
	× W.T.	4" NOM. DIAMETER
SMOOTH WALL PVC	.103	
CORRUGATED PE		AASHTO M-252

NON-PERFORATED OUTLET PIPE FOR USE UNDER COMMERCIAL ENTRANCES AND FOR OUTLETS

TYPE OF PIPE	CRUSHING STRENGTH	
	× W.T.	4" NOM. DIAMETER
SMOOTH WALL PVC	.103	
SMOOTH WALL PE		70 PSI ×××

× WALL THICKNESS (MIN) - INCHES
 ××× TESTED ACCORDING TO ASTM D-2412 AT 5% DEFLECTION.

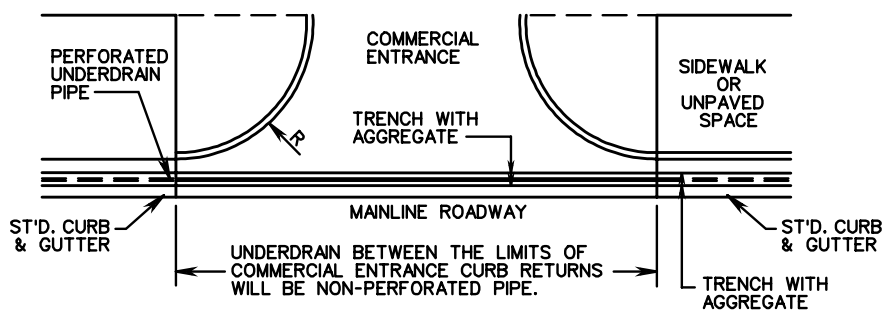

SPECIFICATION REFERENCE
240
501
701

STANDARD RETROFIT EDGEDRAIN

VIRGINIA DEPARTMENT OF TRANSPORTATION



ROAD AND BRIDGE STANDARDS

REVISION DATE	SHEET 1 OF 1
	108.09

THIS PAGE INTENTIONALLY LEFT BLANK



ROAD AND BRIDGE STANDARDS

SHEET 1 OF 1

REVISION DATE

108.10

VIRGINIA DEPARTMENT OF TRANSPORTATION

SPECIFICATION
REFERENCE

OUTSIDE ROAD DITCHES

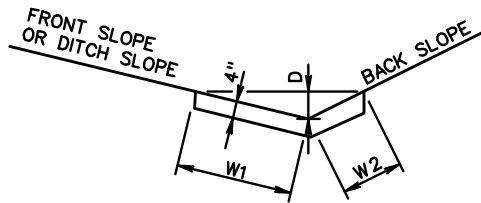

TYPE	D	FRONT SLOPE	BACK SLOPE	W1	W2	K	SQ. YDS. SURFACE AREA/LIN. FT.
A1	6"	6:1	4:1	3'-0"	2'-1"	48	0.565
A1	8"	6:1	4:1	4'-1"	2'-9"	104	0.759
A2	6"	6:1	3:1	3'-0"	1'-7"	42	0.509
A2	8"	6:1	3:1	4'-1"	2'-1"	92	0.685
A3	6"	6:1	2:1	3'-0"	1'-2"	38	0.463
A3	8"	6:1	2:1	4'-1"	1'-6"	82	0.620
B1	6"	4:1	4:1	2'-1"	2'-1"	38	0.463
B1	8"	4:1	4:1	2'-9"	2'-9"	82	0.611
B2	8"	4:1	3:1	2'-9"	2'-1"	72	0.537
B2	10"	4:1	3:1	3'-5"	2'-8"	130	0.676
B3	8"	4:1	2:1	2'-9"	1'-6"	60	0.472
B3	10"	4:1	2:1	3'-5"	1'-10"	111	0.583
B4	8"	4:1	1/2:1	2'-9"	1'-2"	55	0.435
B4	10"	4:1	1/2:1	3'-5"	1'-6"	101	0.546
C1	8"	3:1	2:1	2'-1"	1'-6"	50	0.398
C1	10"	3:1	2:1	2'-8"	1'-10"	92	0.500
C2	10"	3:1	1/2:1	2'-8"	1'-6"	80	0.463
C3	10"	3:1	1:1	2'-8"	1'-2"	70	0.426

MEDIAN DITCH

TYPE D

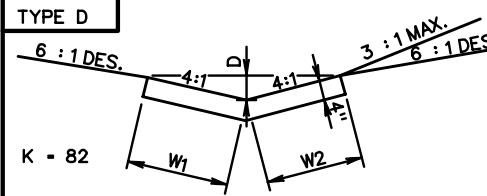

D - DEPTH	W ₁	W ₂	SQ. YDS. SURFACE AREA PER LIN. FT.
8"	2'-9"	2'-9"	0.611

DITCH AT TOE OF FILL OR TOP OF CUT

TYPE E

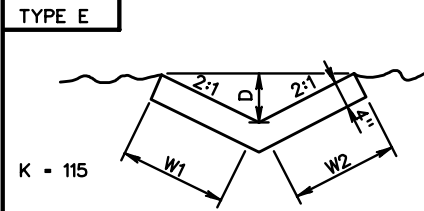

12"	2'-3"	2'-3"	0.500
-----	-------	-------	-------

CURTAIN WALL DETAIL

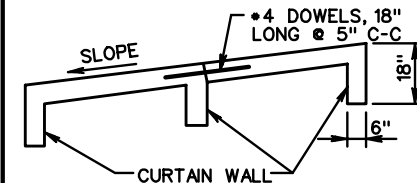

CURTAIN WALL TO BE LOCATED AT BEGINNING AN END OF ALL CHANNELS AND ON THE LOWER END OF EACH EXPANSION JOINT.

PLAN FOR TRANSITION OF PAVED MEDIAN DITCH TO MEDIAN DROP INLET GUTTER

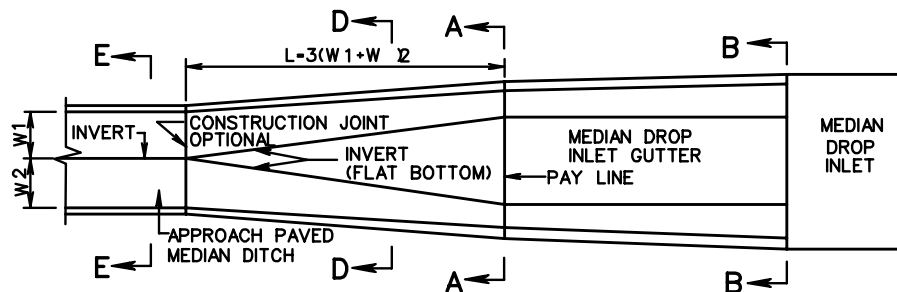

NOTES:
 FOR SECTION A-A AND B-B SEE STANDARDS DI-7, 7A AND 7B.
 TRADITIONAL PORTION OF PAVED DITCH TO BE PAID FOR AT THE SAME PRICE BID PER SQ. YARD FOR APPROACH PAVED MEDIAN DITCH.
 STANDARD PG-2A DITCHES TO BE CLASS A3 CONCRETE.

ALTERNATE METHOD OF FORMING DITCHES

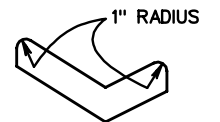
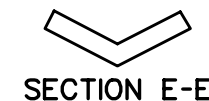

NOTE:
 ALL DITCHES MAY BE CONSTRUCTED WITH VERTICAL SIDES AT THE OPTION OF THE CONTRACTOR.

SPECIFICATION REFERENCE

502

STANDARD PAVED DITCHES

VIRGINIA DEPARTMENT OF TRANSPORTATION

VDOT

ROAD AND BRIDGE STANDARDS

REVISION DATE

SHEET 1 OF 1

109.01

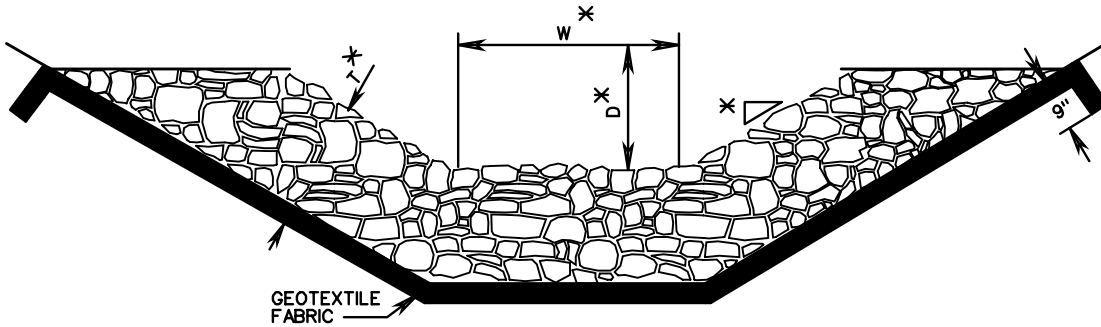

TYPE I
RIPRAP DITCH PROTECTION

MINIMUM THICKNESS "T"

RIP RAP CLASS	MINIMUM "T"
CLASS AI	20"
CLASS I	26"
CLASS II	38"
CLASS III	53"

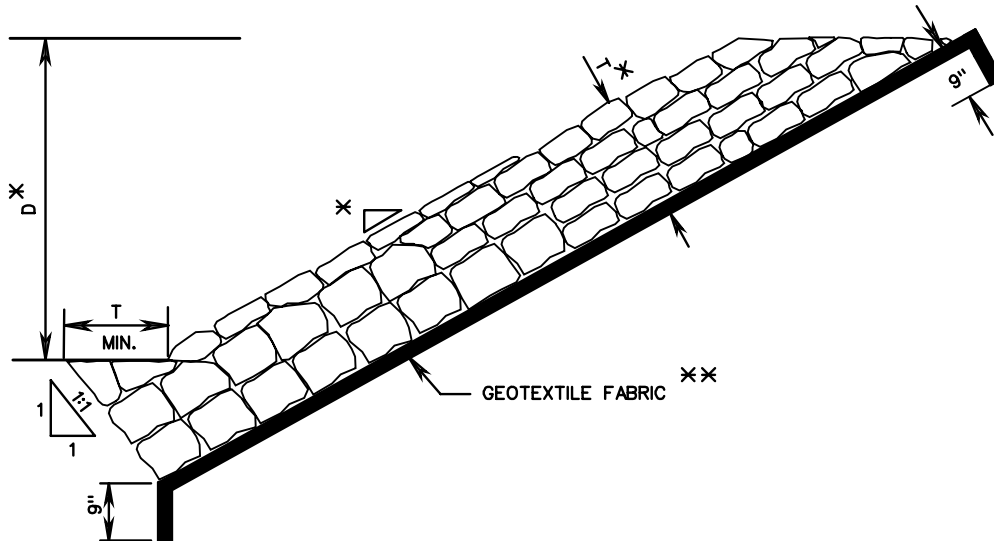

TYPE II
RIPRAP SLOPE PROTECTION

NOTES:

- ×× RIP RAP BEDDING MATERIAL
- GEOTEXTILE FABRIC TO BE PROVIDED UNDER ALL RIPRAP INSTALLATIONS CLASS AI, CLASS I AND CLASS II UNLESS OTHERWISE NOTED ON THE PLANS OR DIRECTED BY THE ENGINEER.
- RIPRAP INSTALLATIONS OF CLASS III SHALL HAVE AN INTERMEDIATE AGGREGATE BEDDING LAYER(S) AS SPECIFIED ON THE PLANS BASED ON GEOTECHNICAL RECOMMENDATIONS.
- * SEE TYPICAL SECTION SHOWN ON PLANS FOR SIDE SLOPE, BOTTOM WIDTH AND DEPTH OF CHANNEL AND RIPRAP THICKNESS.



ROAD AND BRIDGE STANDARDS

STANDARD RIP RAP DITCH & SLOPE PROTECTION
PG-3

SPECIFICATION
REFERENCE

SHEET 1 OF 1

REVISION DATE

109.02

VIRGINIA DEPARTMENT OF TRANSPORTATION

245
414

SCHEDULE OF REINFORCING STEEL

MARK	NO.	LENGTH		SIZE	SPACING C-C	SHAPE
		2:1	1/2:1			
F	3	1'-2"	1'-2"	4	4"	STRAIGHT
G	9	1'-5"	1'-5"	4	6"	STRAIGHT
DOWELS	10	1'-6"	1'-6"	4	5"	STRAIGHT

NO. SHOWN ARE FOR ONE ANCHOR LUG, CURTAIN WALL AND JOINT.

APPROXIMATE QUANTITIES

		CLASS A3 CONCRETE	REINFORCING STEEL
		CU. YDS.	LBS.
ANCHOR LUG	2:1	0.0208	2.34
	1/2:1	0.0216	2.34
CURTAIN WALL	2:1	0.099	8.51
	1/2:1	0.100	8.51
JOINT	2:1	—	10.02
	1/2:1	—	10.02

0.425 SQUARE YARDS SURFACE AREA PER LINEAR FOOT OF FLUME.

NOTE:
DOWELS TO BE LOCATED AT ALL REQUIRED JOINTS.
K VALUE = 128

FOR DETAILS OF PIPE SPILLOUTS FOR 12"-24" CULVERTS, SEE STANDARD DRAWINGS PS-2 AND PS-3.

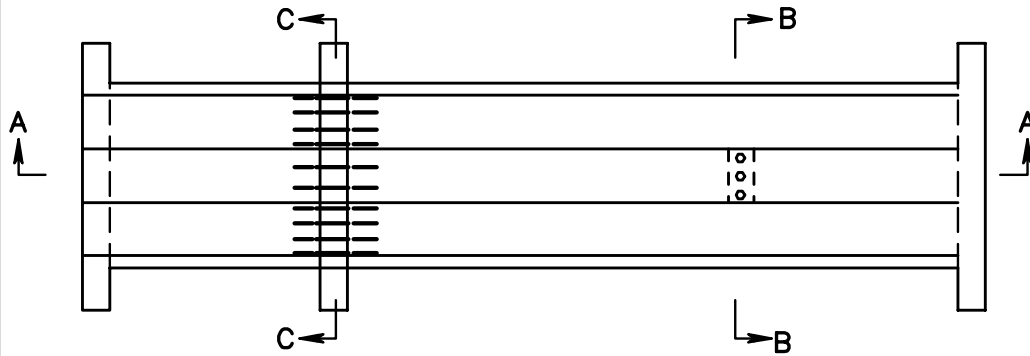

PLAN VIEW

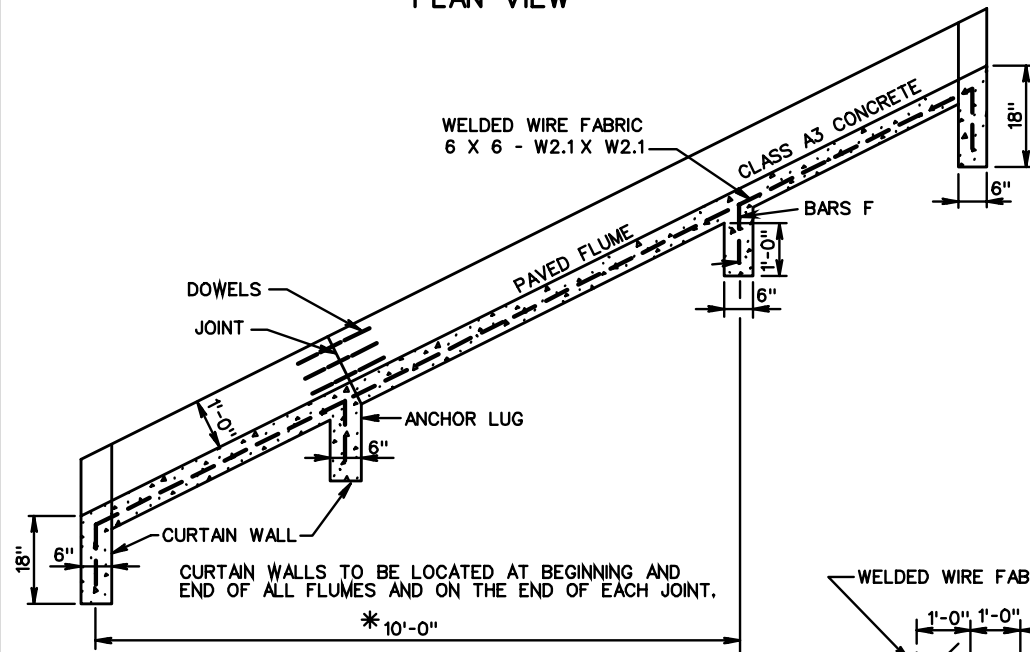

SECTION A-A

*10'-0" C-C MAXIMUM TYPICAL SPACING BETWEEN ANCHOR LUGS. ANCHOR LUG IS TO BE A MAXIMUM OF 2' FROM END OF CHANNEL.

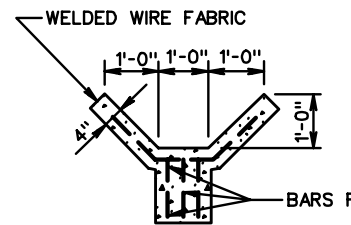

SECTION B-B

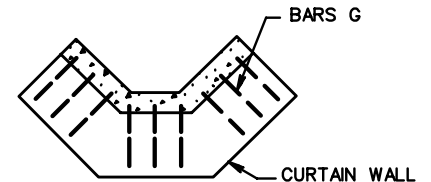

SECTION C-C

SPECIFICATION REFERENCE

502

STANDARD PAVED FLUME FOR 12" - 24" PIPE

VIRGINIA DEPARTMENT OF TRANSPORTATION

VDOT

ROAD AND BRIDGE STANDARDS

REVISION DATE

SHEET 1 OF 1

109.03

 INDICATES CHANNEL WHERE WIRE MESH REINFORCEMENT IS NOT REQUIRED.

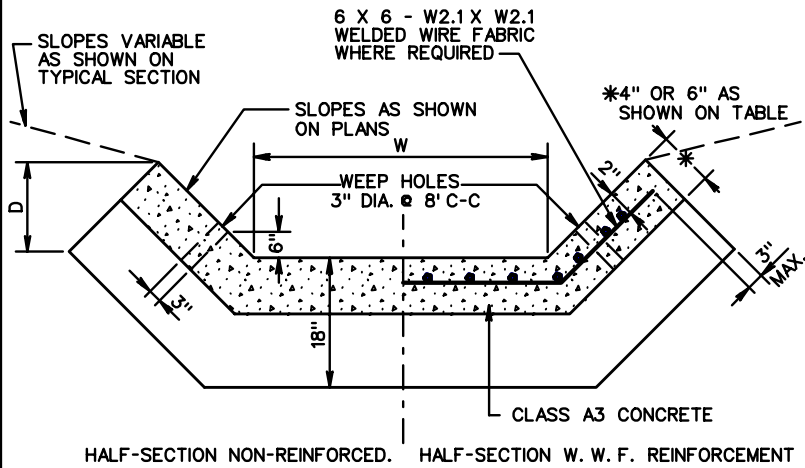

SECTION A-A

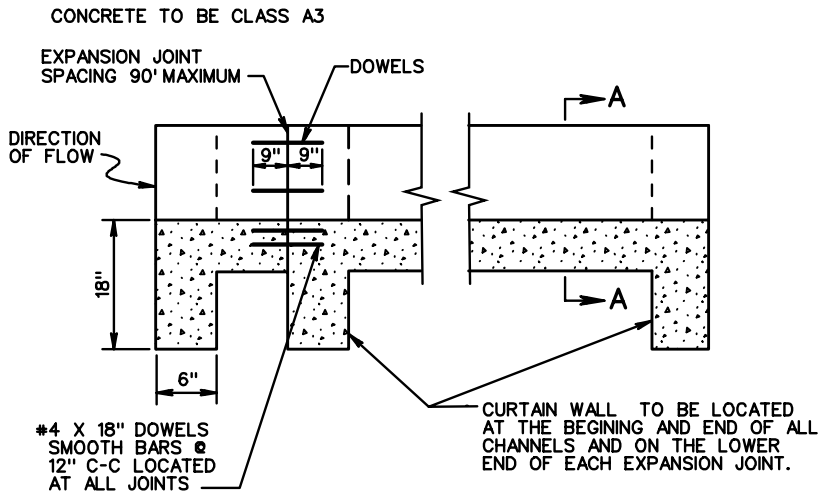

ELEVATION

SQUARE YARDS PER LIN. FT. OF PAVED CHANNEL

CONC. THICKNESS	D	W									
		1'	2'	3'	4'	5'	6'	7'	8'	9'	10'
1:1 SIDE SLOPES											
4"	1'	0.425	0.536	0.648	0.759	0.870	0.981	1.092	1.203	1.314	1.425
	2'	0.740	0.851	0.962	1.073	1.184	1.295	1.406	1.517	1.629	1.740
	3'	1.054	1.165	1.276	1.387	1.498	1.609	1.721	1.832	1.943	2.054
	4'	1.368	1.479	1.590	1.702	1.813	1.924	2.035	2.146	2.257	2.368
6"	5'	1.682	1.794	1.905	2.016	2.127	2.238	2.349	2.460	2.571	2.682
	6'	1.997	2.108	2.219	2.330	2.441	2.552	2.663	2.774	2.886	2.997
	7'	2.311	2.422	2.533	2.644	2.755	2.866	2.977	3.089	3.200	3.311
	8'	2.625	2.736	2.848	2.959	3.070	3.181	3.292	3.403	3.514	3.625
	9'	2.940	3.051	3.162	3.273	3.384	3.495	3.606	3.717	3.828	3.939
	10'	3.254	3.365	3.476	3.587	3.698	3.809	3.920	4.032	4.143	4.254
1.5:1 SIDE SLOPES											
4"	1'	0.512	0.623	0.734	0.845	0.956	1.067	1.178	1.290	1.401	1.512
	2'	0.912	1.023	1.135	1.246	1.357	1.468	1.579	1.690	1.801	1.912
	3'	1.313	1.424	1.535	1.646	1.757	1.869	1.980	2.091	2.202	2.313
	4'	1.714	1.825	1.936	2.047	2.158	2.269	2.380	2.491	2.602	2.714
6"	5'	2.114	2.225	2.336	2.448	2.559	2.670	2.781	2.892	3.003	3.114
	6'	2.515	2.626	2.737	2.848	2.959	3.070	3.181	3.293	3.404	3.515
	7'	2.915	3.027	3.138	3.249	3.360	3.471	3.582	3.693	3.804	3.915
	8'	3.316	3.427	3.538	3.649	3.760	3.872	3.983	4.094	4.205	4.316
	9'	3.717	3.828	3.939	4.050	4.161	4.272	4.383	4.494	4.606	4.717
	10'	4.117	4.228	4.340	4.451	4.562	4.673	4.784	4.895	5.006	5.117
2:1 SIDE SLOPES											
4"	1'	0.608	0.719	0.830	0.941	1.052	1.164	1.275	1.386	1.497	1.608
	2'	1.105	1.216	1.327	1.438	1.549	1.660	1.772	1.883	1.994	2.105
	3'	1.602	1.713	1.824	1.935	2.046	2.157	2.268	2.380	2.491	2.602
	4'	2.099	2.210	2.321	2.432	2.543	2.654	2.765	2.876	2.988	3.099
6"	5'	2.596	2.707	2.818	2.929	3.040	3.151	3.262	3.373	3.485	3.596
	6'	3.093	3.204	3.315	3.426	3.537	3.648	3.759	3.870	3.981	4.093
	7'	3.589	3.701	3.812	3.923	4.034	4.145	4.256	4.367	4.478	4.589
	8'	4.086	4.197	4.309	4.420	4.531	4.642	4.753	4.864	4.975	5.086
	9'	4.583	4.694	4.805	4.917	5.028	5.139	5.250	5.361	5.472	5.583
	10'	5.080	5.191	5.302	5.413	5.525	5.636	5.747	5.858	5.969	6.080

NOTES:

DEPTH (D) AND WIDTH (W) TO BE AS SHOWN ON PLANS.
 WEEP HOLES ARE TO BE PROVIDED ON ALL CHANNELS WHERE W IS EQUAL TO OR GREATER THAN 4' AND D IS EQUAL TO OR GREATER THAN 2'.
 WEEP HOLE WITH 12" X 12" PLASTIC HARDWARE CLOTH, 1/4" MESH OR GALVANIZED STEEL WIRE DIAMETER 0.03 INCH, NUMBER 4 MESH, HARDWARE CLOTH ANCHORED FIRMLY TO THE BOTTOM OF THE CHANNEL.



ROAD AND BRIDGE STANDARDS

STANDARD PAVED DITCHES

SPECIFICATION REFERENCE

SHEET 1 OF 1

REVISION DATE

VIRGINIA DEPARTMENT OF TRANSPORTATION

109.04

502

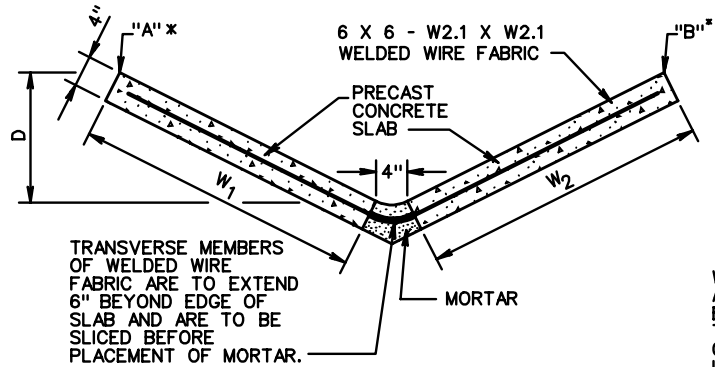

W1	W2	D	K
3'-0"	2'-0"	10"	112
3'-0"	2'-0"	12"	145
3'-0"	3'-0"	10"	137
3'-0"	3'-0"	12"	181
2'-0"	2'-0"	10"	87
2'-0"	2'-0"	12"	111
3'-0"	2'-0"	8"	80
3'-0"	3'-0"	8"	96
2'-0"	2'-0"	8"	64

WIDTH OF SLABS (W) IS TO BE 2'-0" OR 3'-0". ANY COMBINATION OF THESE WIDTHS MAY BE USED DEPENDING ON REQUIREMENTS. THE SLAB LENGTH IS TO BE AT THE OPTION OF THE FABRICATOR BUT IS NOT TO EXCEED LIMITS THAT WOULD FACILITATE EASY HANDLING.

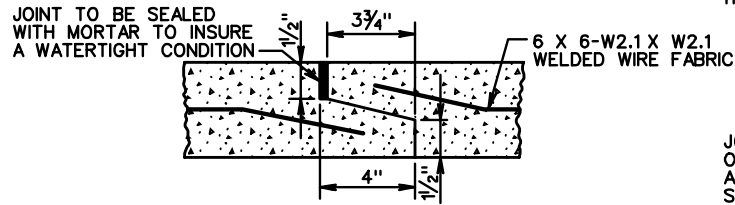

JOINT DETAIL SHOWN IS SUGGESTED ONLY. OTHER FABRICATOR'S DESIGN MEETING THE APPROVAL OF THE ENGINEER MAY BE SUBSTITUTED.

PRECAST CONCRETE VEE DITCH

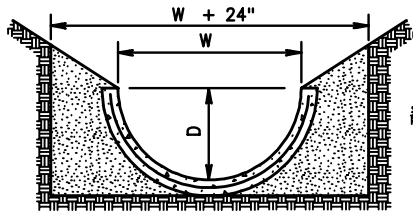

1/2 ROUND SECTION FOR USE ON SLOPES AND FOR FLUMES ONLY.

PIPE SIZE	D	W	K SMOOTH	K C.M.
12"	6"	1'-0"	15	10
15"	7 1/2"	1'-3"	28	17
18"	9"	1'-6"	46	28
21"	10 1/2"	1'-9"	69	43

TRENCH IS TO BE EXCAVATED, PIPE SECTIONS PLACED, AND TRENCH REFILLED. THE MATERIAL PLACED AROUND THE PIPE IS TO BE FREE OF ROCK AND IS TO BE FIRMLY TAMPED.

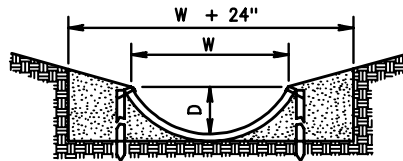

1/3 ROUND SECTION

PIPE SIZE	D	W	K SMOOTH	K C.M.
24"	6"	1'-8 5/16"	27	17
30"	7 1/2"	2'-2"	49	31
36"	9"	2'-7 3/8"	79	49
42"	10 1/2"	3'-3 3/8"	118	74
48"	1'-0"	3'-5 5/8"	173	108
54"	1'-1 1/2"	3'-10 3/4"	234	146
60"	1'-3"	4'-3 5/8"	309	193

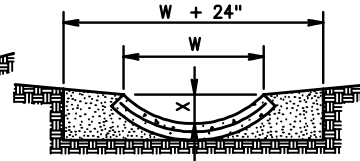

1/4 ROUND SECTION

PIPE SIZE	D	W	K SMOOTH	K C.M.
54"	7 1/8"	3'-2 1/4"	83	52
60"	8 3/4"	3'-6 1/2"	109	68
66"	9 5/8"	3'-10 3/4"	142	88
72"	10 1/2"	4'-3"	179	112
78"	11 3/8"	4'-7 1/4"	235	147
84"	1'-0 1/4"	4'-11 1/2"	269	168
90"	1'-1 1/8"	5'-5 3/4"	325	203

PIPE DRAIN DITCH LINER

CONCRETE VEE DITCH

ALL CONCRETE TO BE 4000 PSI. LIFTING DEVICES OF THE FABRICATOR'S DESIGN ARE TO BE FURNISHED WHEN REQUIRED.

BASIS OF PAYMENT TO BE SQUARE YARDS OF SURFACE MEASURE WHICH IS TO INCLUDE FURNISHING AND PLACING CONCRETE SLABS AND MORTARING JOINTS.

PIPE DRAIN DITCH LINER

PIPE SECTIONS MAY BE USED IN ROADSIDE DITCHES, MEDIAN DITCHES, SLOPE DRAINS, AND FLUMES WITH THE EXCEPTION OF 1/2 ROUND SECTIONS WHICH ARE RESTRICTED TO SLOPE DRAINS AND FLUMES ONLY.

WHEN PIPE DRAIN DITCH LINER IS SUBSTITUTED FOR STANDARD PG-2A OR 4 SPECIFIED ON THE PLANS, THE CONTRACTOR MUST SELECT A "K" VALUE SHOWN HEREON THAT IS EQUAL TO OR GREATER THAN THE "K" VALUE FOR THE TYPE AT STANDARD PAVED DITCH SHOWN BELOW.

"K" IS THE CONVEYANCE FACTOR AS CALCULATED BY THE MANNING'S FORMULA FOR FLOW IN OPEN CHANNELS.

PIPE DRAIN DITCH LINERS ARE TO BE CONSTRUCTED FROM SECTIONS OF CONCRETE PIPE OR REGULAR REINFORCED CONCRETE PIPE, BITUMINIZED FIBER PIPE, CORRUGATED ALUMINUM PIPE, OR CORRUGATED STEEL PIPE. NON-REINFORCED SECTIONS MAY BE USED FOR CONCRETE PIPE SIZES 24" OR LESS.

JOINTS TO BE OF STANDARD MANUFACTURER'S DESIGN FOR REGULAR CONCRETE PIPE AND MAY BE LAPPED, BUTTED WITH A COLLAR, OR BELL AND SPIGOT FOR BITUMINIZED FIBER PIPE. JOINTS FOR CORRUGATED METAL PIPE MAY BE BOLTED OR RIVETED. ALL JOINTS TO BE SEALED TO INSURE A WATER TIGHT BOND.

BITUMINIZED FIBER AND CORRUGATED METAL PIPE TO BE ANCHORED WITH 1" X 4" X 30" PRESSURE PRESERVATIVE TREATED STAKES PLACED AT ALL JOINTS WITH INTERMEDIATE SPACING NOT TO EXCEED 10 FEET. #4 X 30" HOOKED DEFORMED BARS MAY BE SUBSTITUTED IF APPROVED BY THE ENGINEER.

CONCRETE AND CORRUGATED METAL PIPE SECTIONS ARE TO BE AS SPECIFIED IN STANDARD PC-1 AND SPECIFICATIONS FOR MINIMUM HEIGHT OF FILL. BITUMINOUS FIBER PIPE SHALL CONFORM TO SECTION 240 OF THE SPECIFICATIONS, AND IS LIMITED TO SIZES 24" OR LESS.

INLET END OF PIPE DRAIN DITCH LINER INSTALLATION IS TO BE PROTECTED WITH ASPHALT OR CONCRETE TREATMENT AS DIRECTED BY THE ENGINEER TO PREVENT UNDERCUTTING.

COST OF PROTECTION TO BE INCLUDED IN PRICE BID FOR LINEAR FEET OF PIPE DRAIN DITCH LINER.

AT THE OPTION OF THE FABRICATOR, CONCRETE PIPE MAY BE GROOVED FOR SPLITTING.

LIFTING DEVICES OF FABRICATOR'S DESIGN ARE TO BE FURNISHED WHEN REQUIRED.

PIPE SECTIONS ARE TO BE AS SPECIFIED IN PIPE STANDARD PC-1 FOR MINIMUM HEIGHT OF FILL.

SPECIFICATION REFERENCE

232
502

STANDARD PRECAST PAVED DITCHES
(CONCRETE, CORRUGATED METAL & BITUMINOUS FIBER PIPES)

VIRGINIA DEPARTMENT OF TRANSPORTATION



ROAD AND BRIDGE STANDARDS

REVISION DATE

SHEET 1 OF 1

109.05

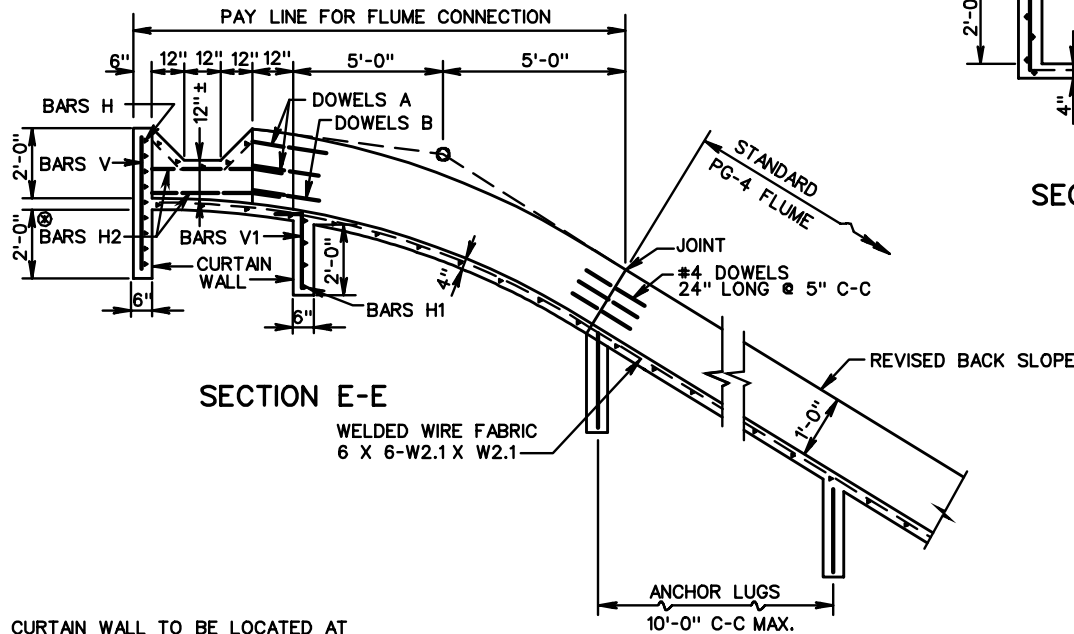
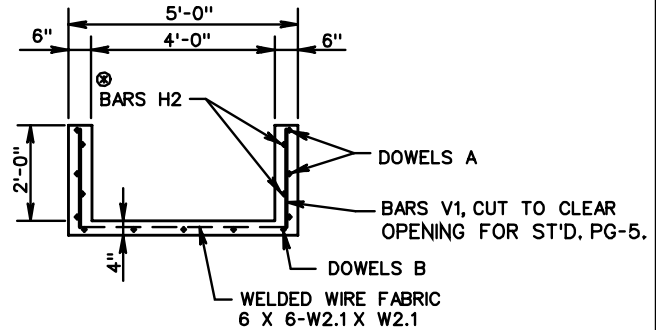
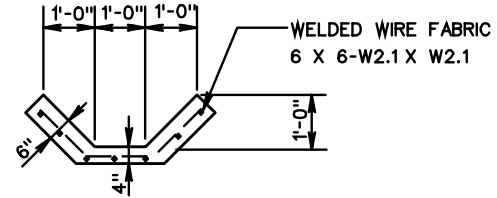
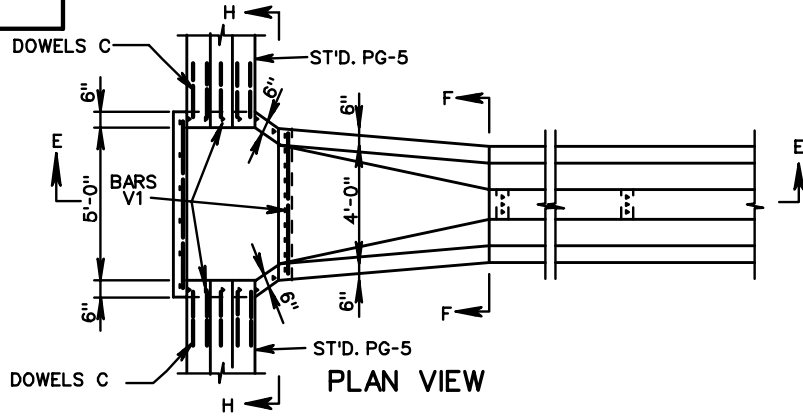

REINFORCING STEEL SCHEDULE				
MARK	SIZE	NO.	SPACING	LENGTH
H	#3	9	6"	5'-8"
H1	#3	4	6"	4'-8"
H2	#3	6	6"	5'-3"
V	#4	6	12"	4'-0"
V1	#4	24	6"	3'-0"
DOWELS A	#4	12	10"	2'-0"
DOWELS B	#4	6	10"	2'-0"
DOWELS C	#4	10	10"	1'-0"
W.W.F.	8GA			83 S.F.

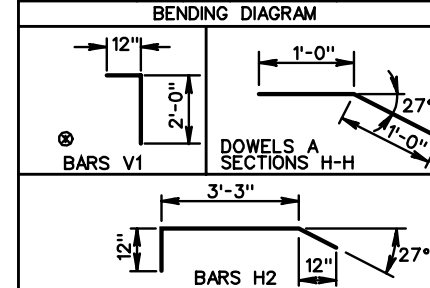

CURTAIN WALL TO BE LOCATED AT BEGINNING AND END OF ALL FLUMES AND ON THE LOWER END OF EACH JOINT.

PRICE BID PER EACH TO INCLUDE DOWELS, WELDED WIRE FABRIC, REINFORCING STEEL, ANCHOR LUGS AND CURTAIN WALL, AND CLASS A-3 CONC.

⊗ FIELD CUT BARS V1 & BARS H2 TO CLEAR OPENING FOR ST'D. PG-5.

APPROXIMATE QUANTITIES	
REINFORCING STEEL 132.9 LBS.	CLASS A3 CONC. 1.7 CU. YDS.



ROAD AND BRIDGE STANDARDS

SHEET 1 OF 1

REVISION DATE

109.06

DITCH FLUME CONNECTOR

VIRGINIA DEPARTMENT OF TRANSPORTATION

SPECIFICATION REFERENCE

502

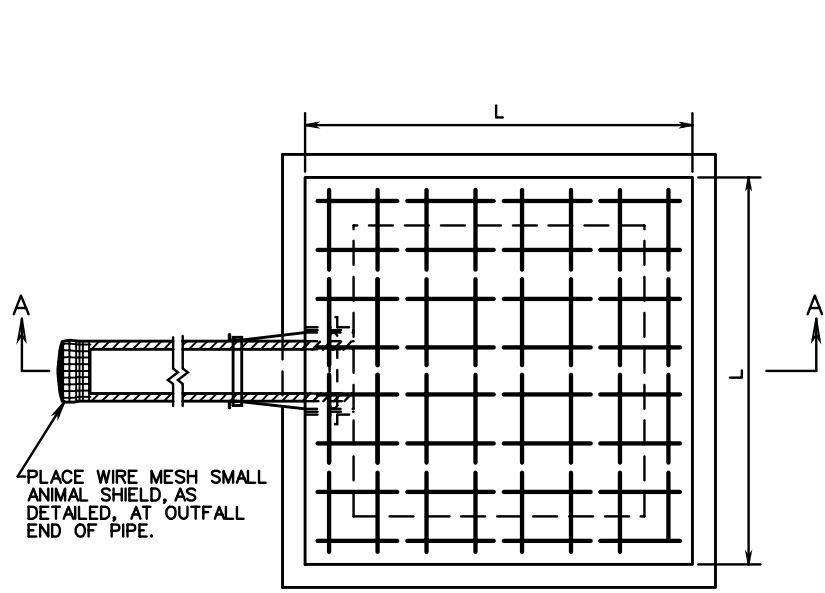

PLAN

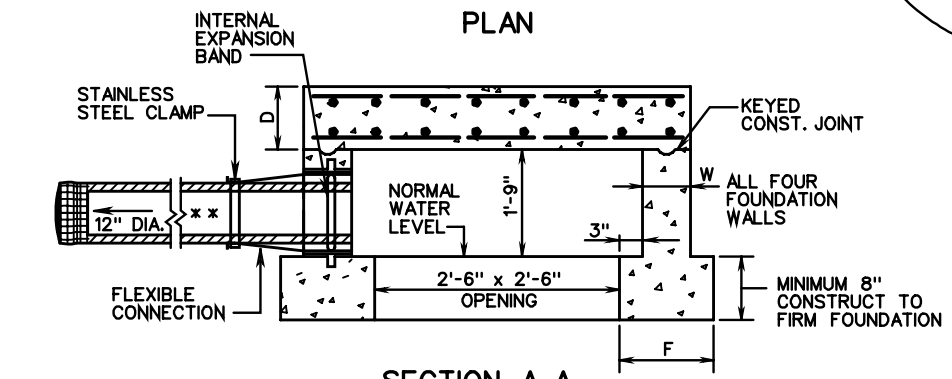

SECTION A-A

** STANDARD RECOMMENDED PIPE IS 12" DUCTILE IRON WATER LINE, PUSH ON JOINTS, CLASS TO BE SPECIFIED BASED UPON HEIGHT OF COVER.

3/4" X 3/4" MESH, HARDWARE CLOTH MIN. 17 GAUGE, GALVANIZED AFTER WEAVING.

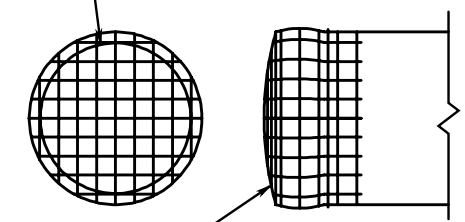

CRIMP AROUND OUTLET END OF PIPE AND SECURE TO PIPE WITH GALVANIZED STEEL WIRE

ANIMAL SHIELD DETAIL

NOTES:
ALL CONCRETE TO BE CLASS A3 IF CAST IN PLACE. FOR PRECAST SEE SHEET 110.02.

CONCRETE QUANTITIES SHOWN ARE BASED ON A 12" DUCTILE IRON WATER LINE. IF OTHER SIZE OR TYPE OF PIPE IS USED QUANTITIES ARE TO BE ADJUSTED ACCORDINGLY.

COST OF WIRE MESH SHIELD AT OUTFALL END OF PIPE IS TO BE INCLUDED IN PRICE BID FOR PIPE.

THIS ITEM MAY BE PRECAST OR CAST IN PLACE.

CONTRACTOR IS TO PROVIDE OPENING FOR PIPE AND FLEXIBLE CONNECTOR BY CORING OR CAST-IN-PLACE SLEEVE WITH WATER STOP COLLAR.

PIPE(S) SHALL BE CONNECTED TO SPRING BOX WITH A FLEXIBLE BOOT MEETING ASTM SPECIFICATION C-923. COST OF FLEXIBLE CONNECTION TO BE INCLUDED IN BID PRICE FOR SPRING BOX. BOOT SHALL BE MADE FROM NEOPRENE RUBBER AND HAVE A 3/8" MINIMUM WALL THICKNESS THROUGHOUT. THE INTERNAL EXPANSION BAND TO SECURE THE BOOT IN PLACE SHALL CONFORM TO ALUMINUM MATERIAL SPECIFICATION 6061-T6. THE EXTERNAL BAND TO CLAMP AND SEAL THE BOOT TO THE PIPE SHALL BE STAINLESS STEEL-CORROSION RESISTANT CONFORMING TO ASTM SPECIFICATION A-167. THE OPENING TO RECEIVE THE FLEXIBLE CONNECTION SHALL BE CORE DRILLED AND IS TO BE CONSTRUCTED TO ALLOW FOR LATERAL AND VERTICAL MOVEMENT, AS WELL AS ANGULAR ADJUSTMENT THRU 20 DEGREES. ALL FIELD INSTALLATION OF PIPE TO SPRING BOX USING FLEXIBLE BOOT SHALL BE COMPLETED IN ACCORDANCE WITH THE MANUFACTURER'S RECOMMENDATIONS AND SPECIFICATIONS.

HEIGHT OF FILL	SIZE (L)	TOP SLAB (D)	SIDEWALLS (W)	FOOTING WIDTH (F)	REINFORCING STEEL				QUANTITIES		
					NO. REQ'D.	LENGTH	SIZE	SPACING C-C	CU. YDS. CONC.	REINF. STEEL LBS.	INCREMENT * CU. YDS.
BELOW 25'	4'	8"	6"	12"	32	3'-9"	#4	6"	1.189	80	0.043
25' - 50'	4'-4"	8"	8"	14"	32	4'-1"	#5	6"	1.512	136	0.053

* QUANTITIES SHOWN ARE BASED ON A 8" DEPTH OF FOOTING, ADD INCREMENTAL QUANTITY FOR EACH ADDITIONAL 1" OF DEPTH.

SPECIFICATION REFERENCE
105
232
302

STANDARD SPRING BOX

VIRGINIA DEPARTMENT OF TRANSPORTATION

VDOT	
ROAD AND BRIDGE STANDARDS	
REVISION DATE	SHEET 1 OF 1
	110.01

SB-1 PC

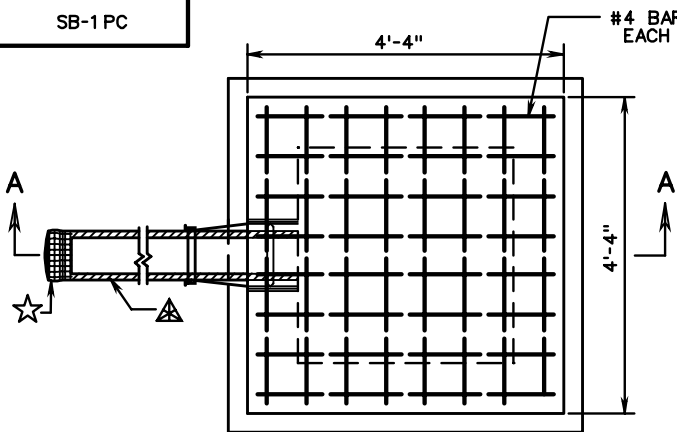

PLAN
(SQUARE)

#4 BARS @ 6" C-C EACH WAY

☆ 3/4"x3/4" MESH HARDWARE CLOTH, MIN. 17 GAUGE GALVANIZED AFTER WEAVING.

▲ CRIMP AROUND OUTLET END OF PIPE AND SECURE TO PIPE WITH GALVANIZED STEEL WIRE.

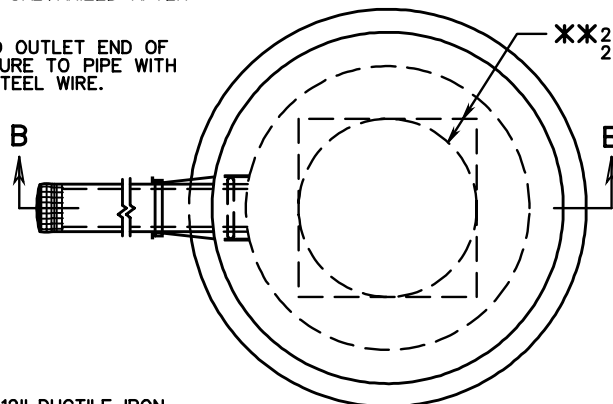

PLAN
(CIRCULAR)

XX 2'-6"x2'-6" OR 2'-6" DIAMETER

* STANDARD RECOMMENDED PIPE IS 12" DUCTILE IRON WATER LINE, PUSH ON JOINTS, CLASS TO BE SPECIFIED BASED UPON HEIGHT OF COVER.

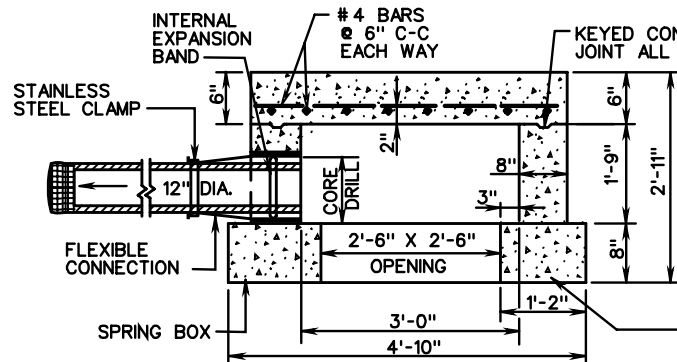

SECTION A-A

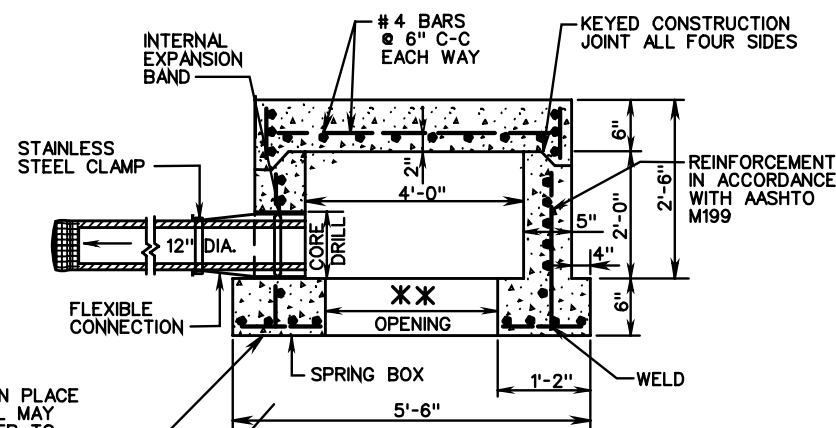

SECTION B-B

ADDITIONAL POURED IN PLACE FOUNDATION MATERIAL MAY BE REQUIRED IN ORDER TO REACH FIRM FOUNDATION.

NOTES:

CONCRETE TO BE 4000 PSI MINIMUM COMPRESSIVE STRENGTH.

REINFORCING STEEL IN ACCORDANCE WITH A.S.T.M. A-615 (REINFORCING BARS).

PIPE(S) SHALL BE CONNECTED TO SPRING BOX WITH A FLEXIBLE BOOT MEETING ASTM SPECIFICATION C-923. COST OF FLEXIBLE CONNECTION TO BE INCLUDED IN BID PRICE FOR SPRING BOX. BOOT SHALL BE MADE FROM NEOPRENE RUBBER AND HAVE A 3/8" MINIMUM WALL THICKNESS THROUGHOUT. THE INTERNAL EXPANSION BAND TO SECURE THE BOOT IN PLACE SHALL CONFORM TO ALUMINUM MATERIAL SPECIFICATION 6061-T6. THE EXTERNAL BAND TO CLAMP AND SEAL THE BOOT TO THE PIPE SHALL BE STAINLESS STEEL-CORROSION RESISTANT CONFORMING TO ASTM SPECIFICATION A-167. THE OPENING TO RECEIVE THE FLEXIBLE CONNECTION SHALL BE CORE DRILLED AND IS TO BE CONSTRUCTED TO ALLOW FOR LATERAL AND VERTICAL MOVEMENT, AS WELL AS ANGULAR ADJUSTMENT THRU 20 DEGREES. ALL FIELD INSTALLATION OF PIPE TO SPRING BOX USING FLEXIBLE BOOT SHALL BE COMPLETED IN ACCORDANCE WITH THE MANUFACTURER'S RECOMMENDATIONS AND SPECIFICATIONS.

DIMENSIONS SHOWN ARE MINIMUM. ACTUAL MEASUREMENTS MAY VARY WITH MANUFACTURER'S TOLERANCES.

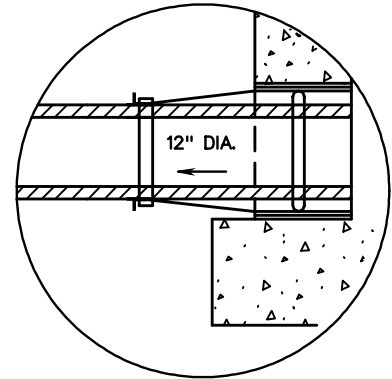

ROAD AND BRIDGE STANDARDS

SHEET 1 OF 1

REVISION DATE

110.02

PRECAST SPRING BOX

VIRGINIA DEPARTMENT OF TRANSPORTATION

SPECIFICATION REFERENCE

105

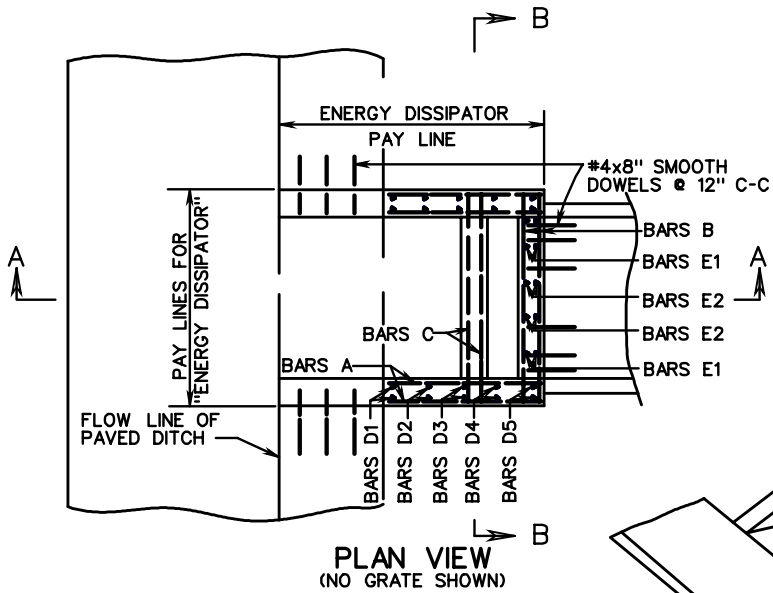

NOTES:

AMOUNT OF PAVED DITCH REPLACED BY "ENERGY DISSIPATOR" TABULATED BY DEPTHS AS SHOWN IN STANDARD PG-2A.

THIS ITEM MAY BE PRECAST OR CAST IN PLACE.

CONCRETE TO BE CLASS A3 IF CAST IN PLACE.

FOR PRECAST SEE SHEET 111.02.

THE 2:1 DESIGN MAY BE USED ON EITHER 1/2:1 OR 2:1 SLOPES.

EG-1-ENERGY DISSIPATOR WITHOUT GRATE.
EG-1A-ENERGY DISSIPATOR WITH GRATE.

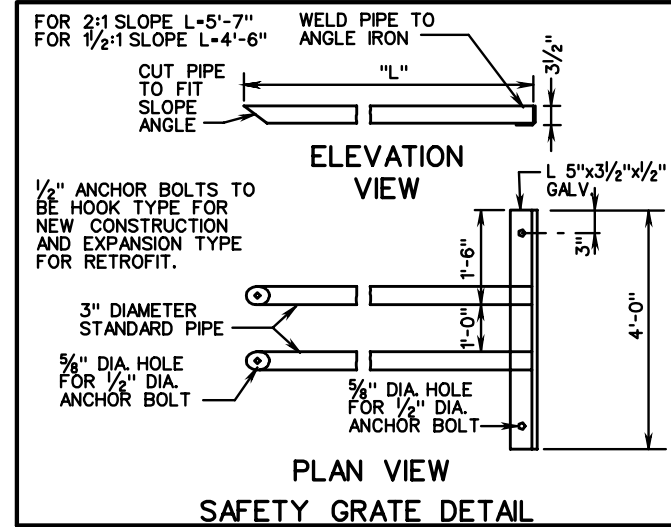
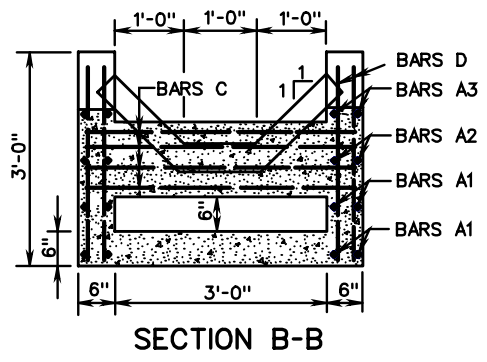
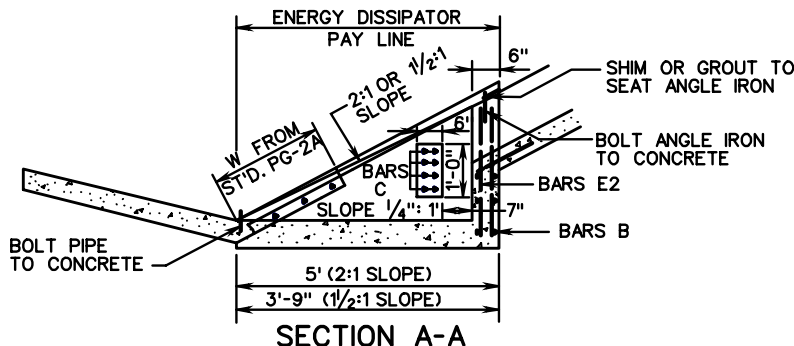

SCHEDULE OF REINFORCING STEEL						
MARK	NO.	LENGTH		SIZE	SPACING C-C	SHAPE
		2:1	1 1/2:1			
A1	8	2'-10"	2'-10"	# 3	8"	STRAIGHT
A2	4	2'-6 1/4"	1'-10"	# 3	8"	STRAIGHT
A3	4	1'-0 3/4"	0'-10"	# 3	8"	STRAIGHT
B	6	3'-9"	3'-9"	# 3	8"	STRAIGHT
C	8	3'-8"	3'-8"	# 4	2 1/2"	STRAIGHT
D1	4	1'-2 1/2"	0'-8"	# 3	8"	STRAIGHT
D2	4	1'-6 1/2"	1'-1 1/2"	# 3	8"	STRAIGHT
D3	4	1'-10 1/2"	1'-7"	# 3	8"	STRAIGHT
D4	4	2'-2 1/2"	2'-0 1/2"	# 3	8"	STRAIGHT
D5	4	2'-6 1/2"	2'-6"	# 3	8"	STRAIGHT
E1	4	1'-11 1/2"	1'-11 1/2"	# 3	8"	STRAIGHT
E2	4	1'-5 1/2"	1'-5 1/2"	# 3	8"	STRAIGHT

APPROXIMATE QUANTITIES			
		CONCRETE	REINFORCING STEEL
		CU. YDS.	LBS.
ENERGY DISSIPATOR	2:1	0.7479	61.20
	1/2:1	0.5921	57.63

SPECIFICATION REFERENCE
502

STANDARD ENERGY DISSIPATOR
FOR USE WITH PAVED FLUMES
VIRGINIA DEPARTMENT OF TRANSPORTATION

VDOT	
ROAD AND BRIDGE STANDARDS	
REVISION DATE	SHEET 1 OF 1
	111.01

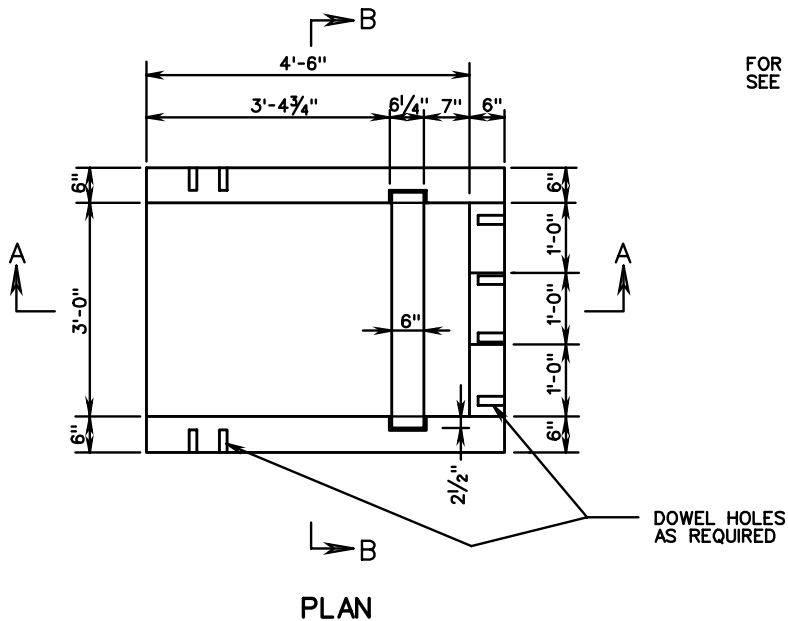

EG-1 PC-ENERGY DISSIPATOR (WITHOUT GRATE)
EG-1A PC-ENERGY DISSIPATOR (WITH GRATE)

FOR DETAILS OF SAFETY GRATE
SEE ST'D. EG-1

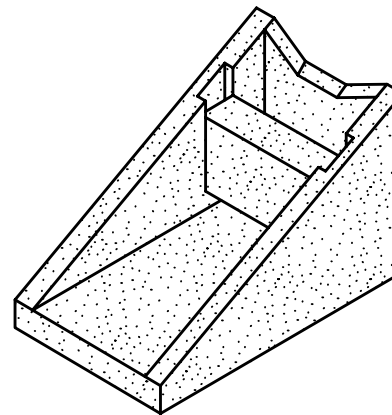

ISOMETRIC VIEW

1. CONCRETE STRENGTH 4000 PSI MINIMUM.
2. REINFORCING SHALL CONFORM TO A.S.T.M. A615, GRADE 40.
3. ALL UNITS SHALL BE FOR A 2:1 SLOPE UNLESS SPECIAL ORDERED.
4. DOWEL HOLES PROVIDED TO PREVENT SETTLEMENT OF ADJACENT CONCRETE.
5. DIMENSIONS SHOWN FOR CONCRETE THICKNESS ARE MINIMUM. ACTUAL MEASUREMENTS MAY VARY WITH MANUFACTURER'S TOLERANCES.

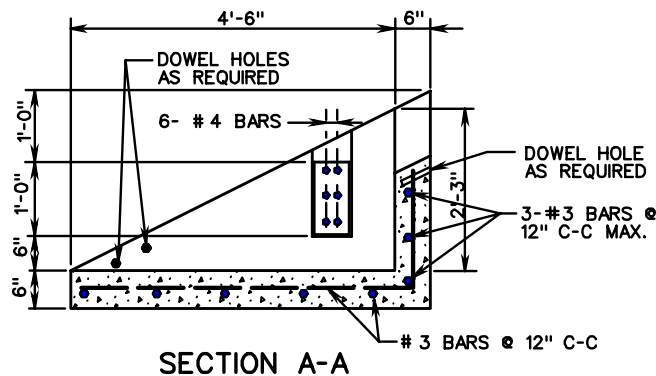

SECTION A-A

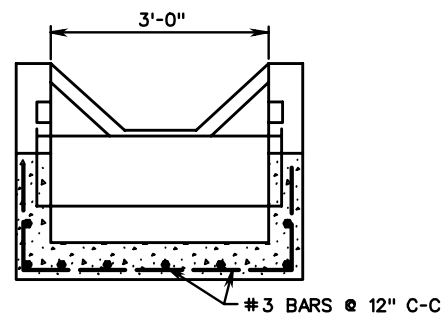

SECTION B-B



ROAD AND BRIDGE STANDARDS

SHEET 1 OF 1

REVISION DATE

111.02

PRECAST ENERGY DISSIPATOR

VIRGINIA DEPARTMENT OF TRANSPORTATION

SPECIFICATION
REFERENCE

105

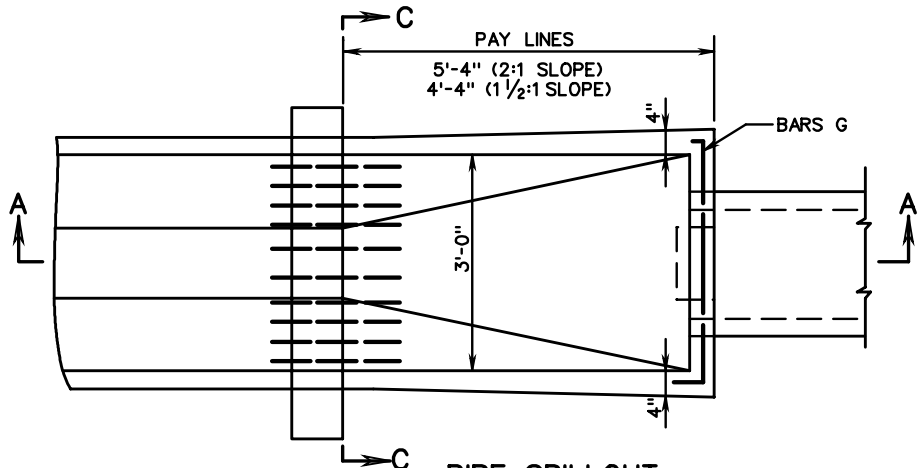

PIPE SPILLOUT
PLAN VIEW

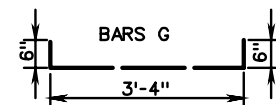

- * 12" PIPE - 3 BARS - 10.68 LBS. REINFORCING STEEL
- 15" PIPE - 2 BARS - 7.79 LBS. REINFORCING STEEL
- 18" PIPE - 2 BARS - 7.79 LBS. REINFORCING STEEL

SCHEDULE OF REINFORCING STEEL						
MARK	NO.	LENGTH		SIZE	SPACING C-C	SHAPE
		2:1	1/2:1			
F	5	1'-0"	1'-0"	4	4"	STRAIGHT
G	*	4'-4"	4'-4"	4	4"	BENT
L	12	2'-0"		3	12"	BENT
L	10		2'-0"	3	12"	BENT

‡ QUANTITIES BASED
ON 18" PIPE.

APPROXIMATE QUANTITIES			
PIPE SPILLOUT	SLOPE	CLASS A3 CONCRETE	REINFORCING STEEL
		CUBIC YARDS	LBS.
PIPE	2:1	‡ 0.482	*
SPILLOUT	1/2:1	‡ 0.440	*

NOTE:
DOWELS TO BE LOCATED AT ALL
REQUIRED JOINTS.

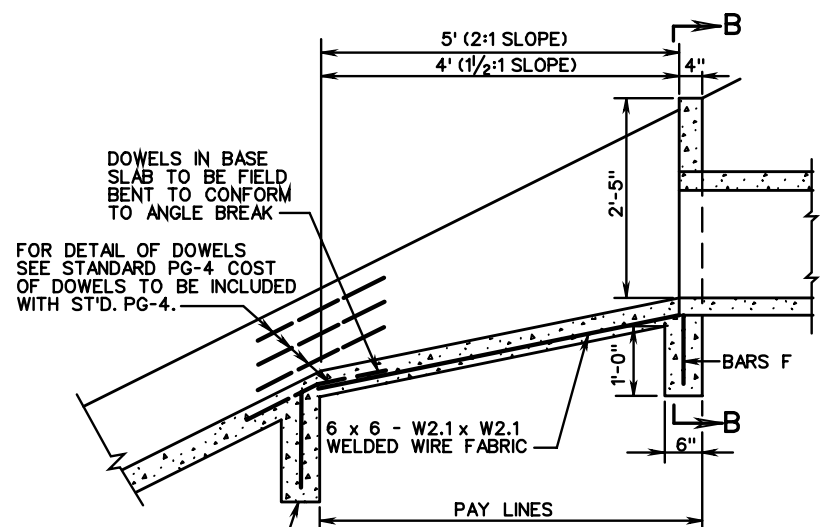

PIPE SPILLOUT
SECTION A-A

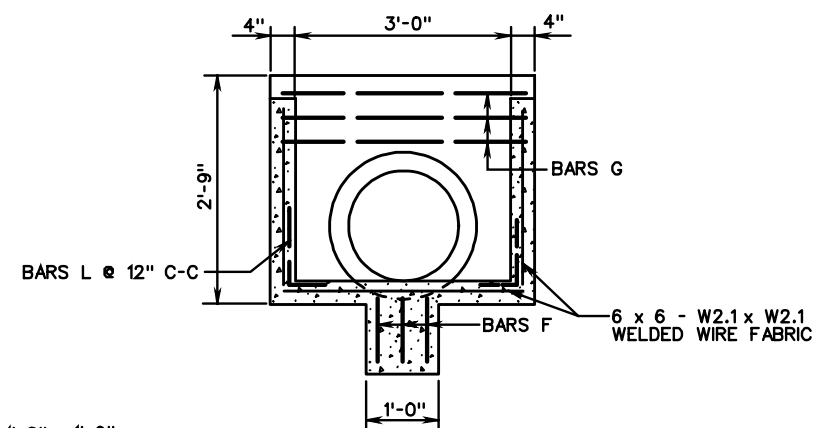

SECTION B-B

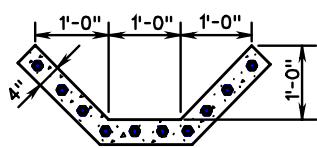

SECTION C-C

SPECIFICATION REFERENCE
302

STANDARD PIPE SPILLOUT FOR 12" - 18" PIPE CULVERTS

VIRGINIA DEPARTMENT OF TRANSPORTATION

VDOT ROAD AND BRIDGE STANDARDS	
REVISION DATE	SHEET 1 OF 1
112.01	

PS-3

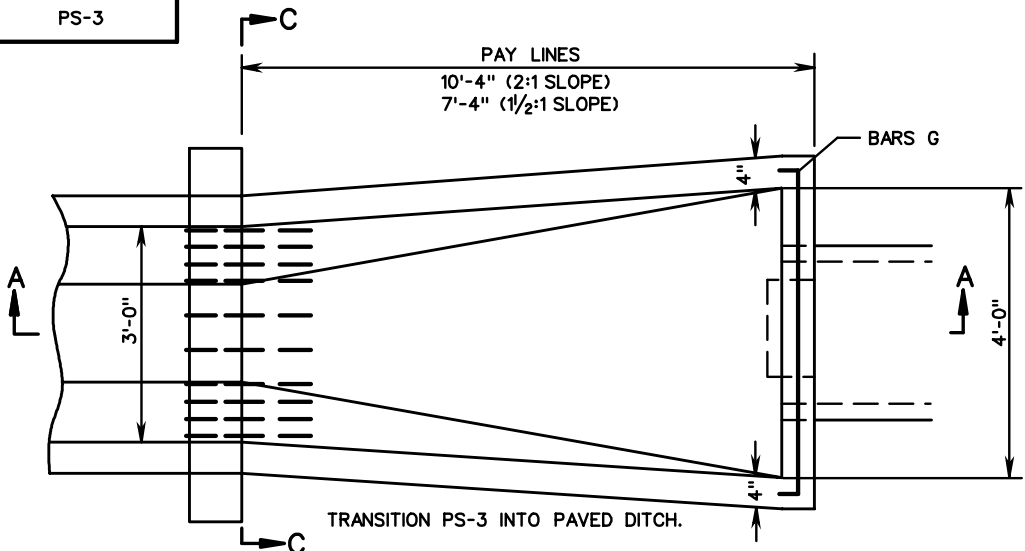

TRANSITION PS-3 INTO PAVED DITCH.
PIPE SPILLOUT
PLAN VIEW

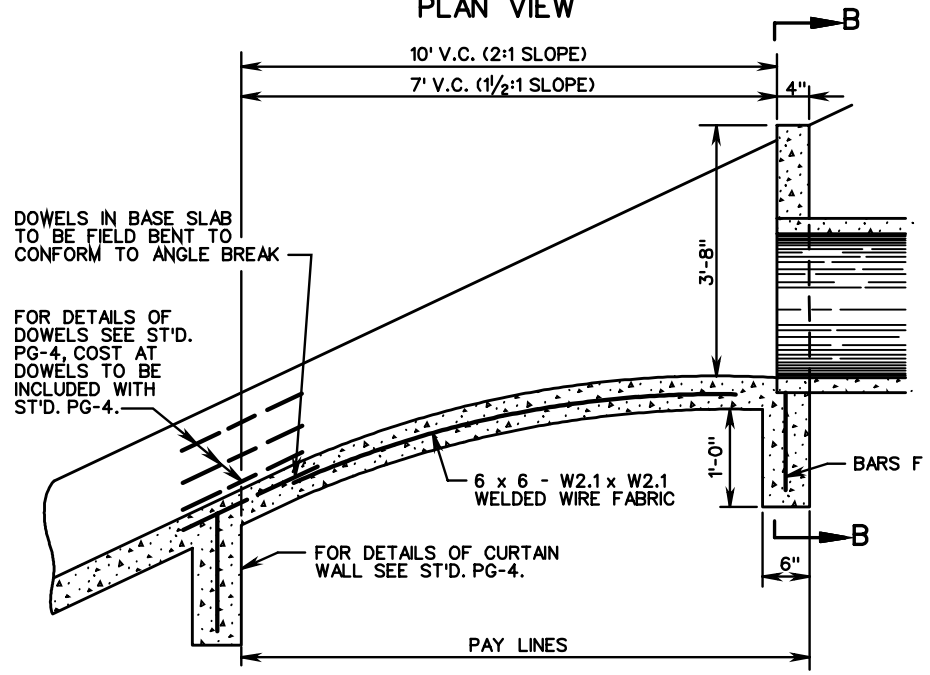

PIPE SPILLOUT
SECTION A-A

DOWELS IN BASE SLAB TO BE FIELD BENT TO CONFORM TO ANGLE BREAK

FOR DETAILS OF DOWELS SEE ST'D. PG-4. COST AT DOWELS TO BE INCLUDED WITH ST'D. PG-4.

FOR DETAILS OF CURTAIN WALL SEE ST'D. PG-4.

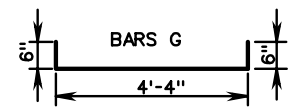

- * 30" PIPE = 2 BARS - 10.46 LBS. REINFORCING STEEL
- 24" PIPE = 4 BARS - 17.59 LBS. REINFORCING STEEL
- 21" PIPE = 5 BARS - 21.15 LBS. REINFORCING STEEL

SCHEDULE OF REINFORCING STEEL						
MARK	NO.	LENGTH		SIZE	SPACING C-C	SHAPE
		2:1	1/2:1			
F	5	1'-0"	1'-0"	4	4"	STRAIGHT
G	*	5'-4"	5'-4"	4	4"	BENT
L	22	2'-0"		3	12"	BENT
L	16		2'-0"	3	12"	BENT

‡ QUANTITIES BASED ON 30" PIPE.

APPROXIMATE QUANTITIES			
PIPE SPILLOUT		CLASS A3 CONCRETE	REINFORCING STEEL
		CU. YARDS.	LBS.
	2:1	‡ 1.351	*
	1/2:1	‡ 1.037	*

NOTE: DOWELS TO BE LOCATED AT ALL REQUIRED JOINTS.

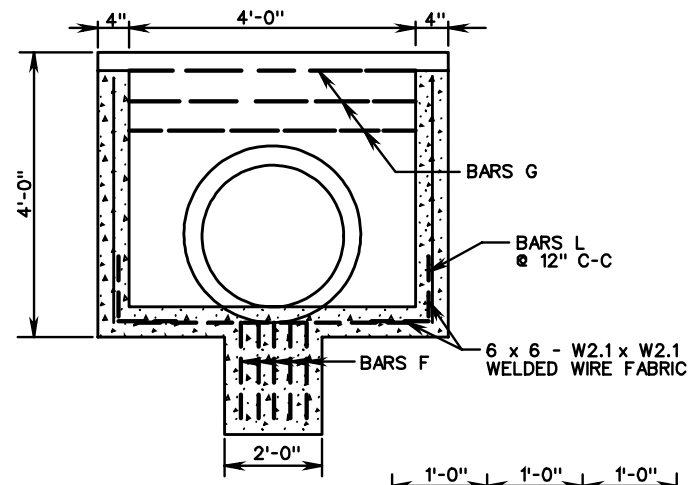

SECTION B-B

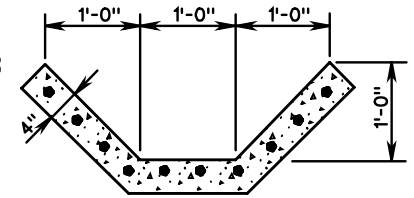

SECTION C-C



ROAD AND BRIDGE STANDARDS

SHEET 1 OF 1

REVISION DATE

112.02

STANDARD PIPE SPILLOUT FOR 21" - 30" PIPE CULVERTS

VIRGINIA DEPARTMENT OF TRANSPORTATION

SPECIFICATION
REFERENCE

302

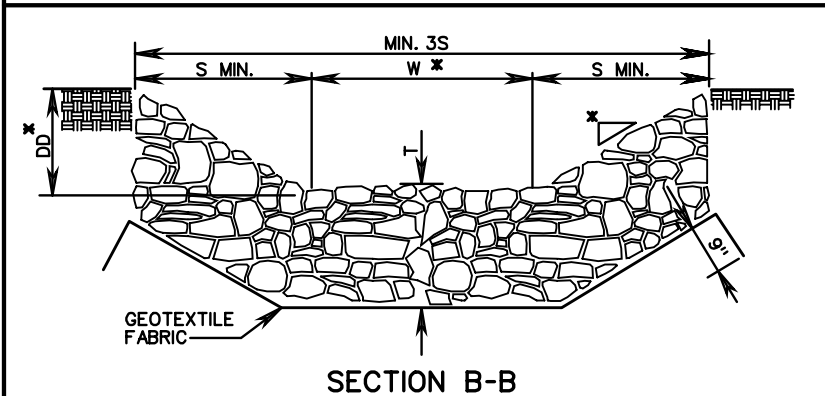
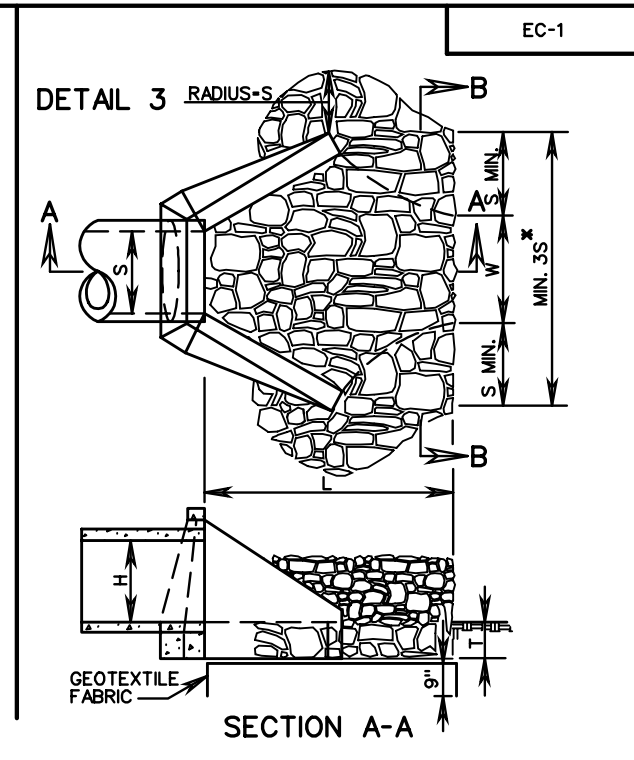
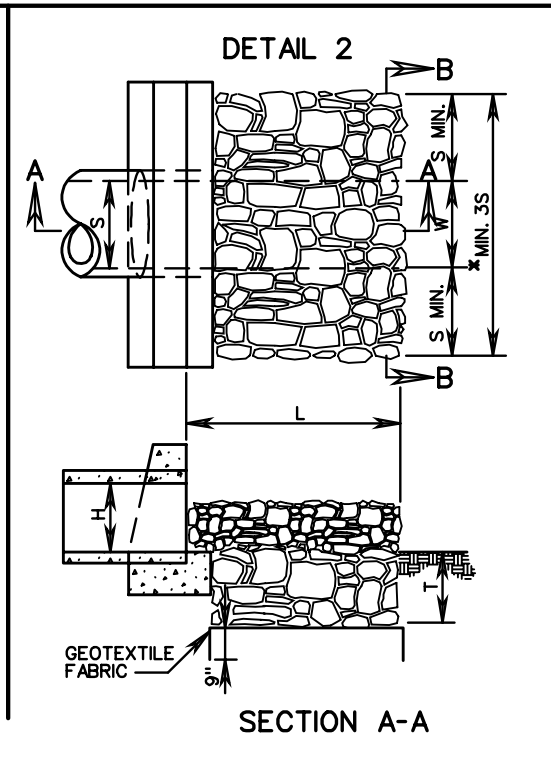
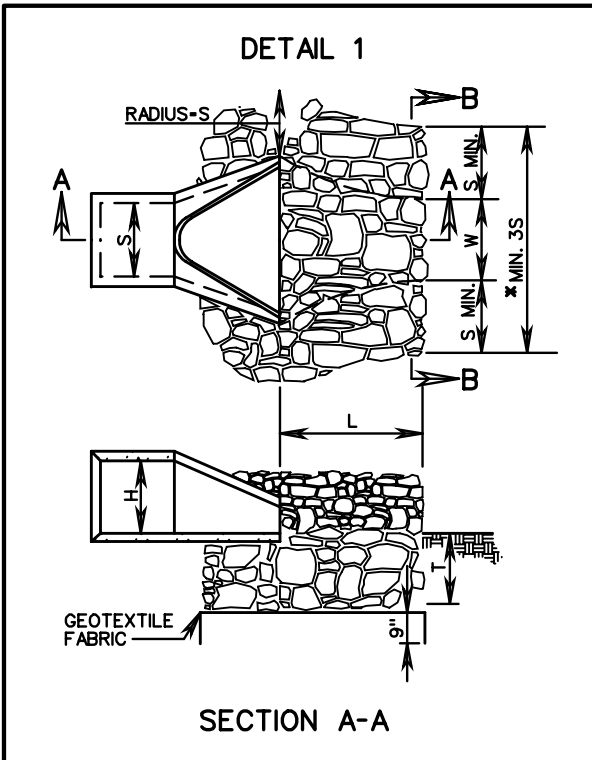

NOTES:

1. FOR MULTIPLE LINE INSTALLATIONS, DIMENSION S IS TO GOVERN THE PROTECTION OUTSIDE THE CHANNEL WIDTH (W).
 2. ON ANY INSTALLATION REQUIRING CULVERT OUTLET PROTECTION WHERE NO ENDWALL OR ENDSECTION IS SPECIFIED ON THE PLANS, CONSTRUCTION IS TO BE IN ACCORDANCE WITH DETAIL 2 SHOWN ABOVE.
 3. GEOTEXTILE FABRIC TO BE INSTALLED UNDER CLASS A1, I, AND II MATERIALS IN ACCORDANCE WITH THE SPECIFICATIONS.
 4. S = DIAMETER OF CIRCULAR CULVERT OR SPAN FOR BOX, ELLIPTICAL OR ARCH CULVERT. H = DIAMETER OF CIRCULAR CULVERT OR RISE/HEIGHT FOR BOX, ELLIPTICAL OR ARCH CULVERT.
- * USE TYPICAL SECTION SHOWN ON PLANS FOR SIDE SLOPE, BOTTOM WIDTH AND DEPTH OF CHANNEL OR MATCH EXISTING DITCH OR NATURAL GROUND.

TYPE OF OUTLET PROTECTION MATERIAL		MAXIMUM OUTLET VELOCITY (FOR DESIGN STORM)	MINIMUM "T" (INCHES)
CLASS A1	CLASS A1 DRY RIPRAP	8 fps	18
CLASS I	CLASS I DRY RIPRAP	14 fps	24
CLASS II	CLASS II DRY RIPRAP	19 fps	36

OUTLET PROTECTION MINIMUM LENGTH (L)	
TYPE A INSTALLATION	3H
TYPE B INSTALLATION	5H

SPECIFICATION REFERENCE
204
245
303
414

CULVERT OUTLET PROTECTION

VIRGINIA DEPARTMENT OF TRANSPORTATION

VDOT ROAD AND BRIDGE STANDARDS	
REVISION DATE	SHEET 1 OF 1
113.01	

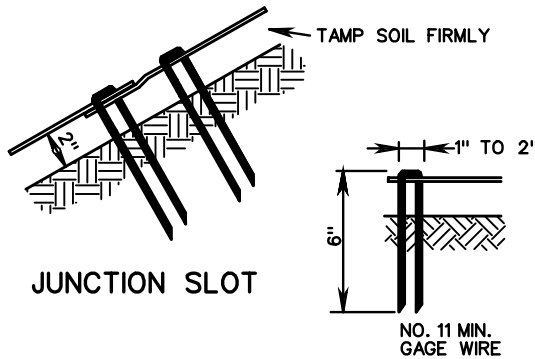
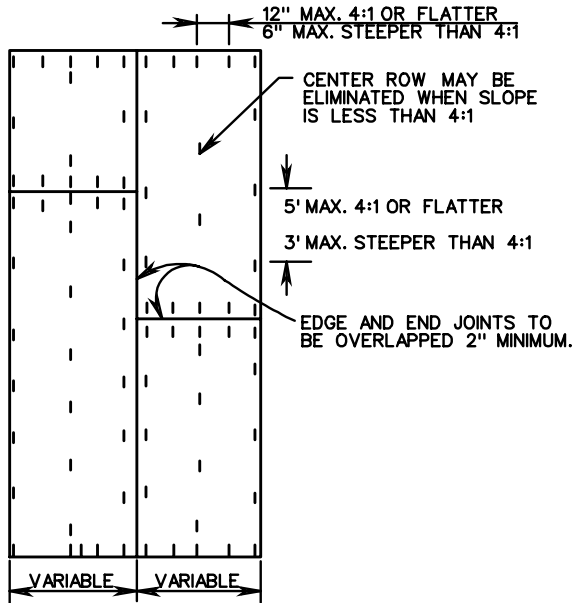

JUNCTION SLOT

SOIL RETENTION MAT

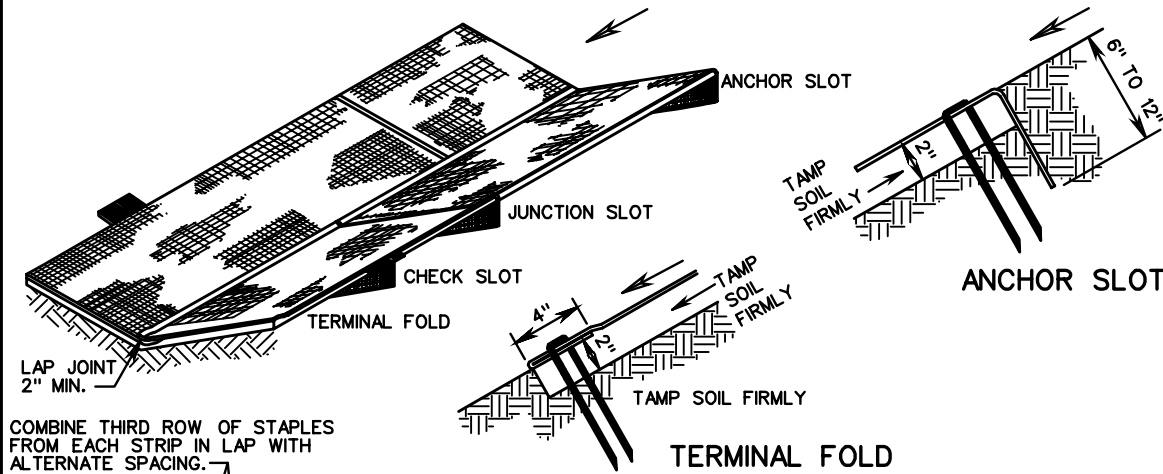

COMBINE THIRD ROW OF STAPLES FROM EACH STRIP IN LAP WITH ALTERNATE SPACING.

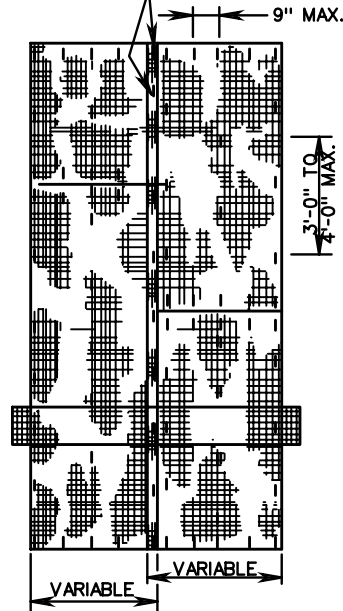

PLAN VIEW STAPLING DIAGRAM

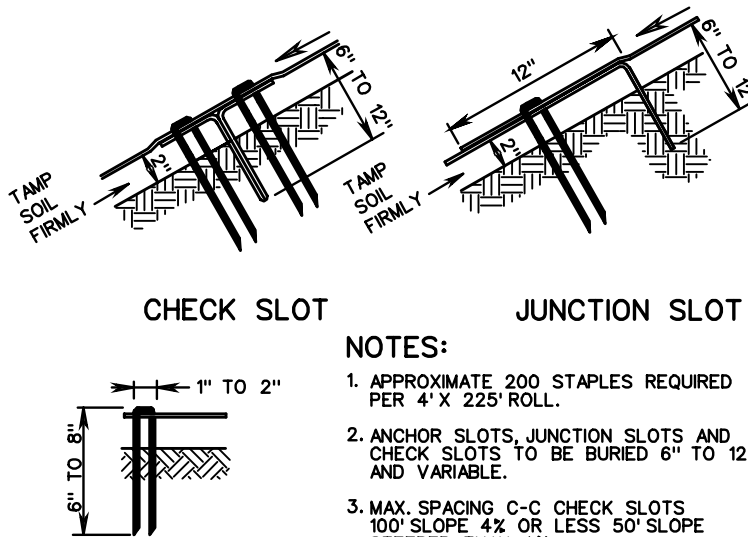

CHECK SLOT

JUNCTION SLOT

JUTE MESH

NOTES:

1. APPROXIMATE 200 STAPLES REQUIRED PER 4' X 225' ROLL.
2. ANCHOR SLOTS, JUNCTION SLOTS AND CHECK SLOTS TO BE BURIED 6" TO 12" AND VARIABLE.
3. MAX. SPACING C-C CHECK SLOTS 100' SLOPE 4% OR LESS 50' SLOPE STEEPER THAN 4%.
4. STAPLES FORMED FROM NO. 8 STEEL WIRE 8" STAPLE MINIMUM LENGTH FOR SANDY SOIL 6" STAPLE MINIMUM LENGTH FOR OTHER SOIL.

GENERAL NOTES:

1. BASIS OF PAYMENT TO BE SQUARE YARDS OF PROTECTIVE COVERING COMPLETE IN PLACE. PROTECTIVE COVERING IS TO BE LOCATED AS INDICATED ON THE PLANS IN ACCORDANCE WITH THE DIMENSIONS SPECIFIED ON TYPICAL SECTION.
2. "T-TOP" STAPLES OR OTHER MANUFACTURER'S DESIGN APPROVED BY THE ENGINEER MAY BE SUBSTITUTED FOR THE STAPLES SHOWN.
3. JUTE MESH OR SOIL RETENTION MAT IN ACCORDANCE WITH THE SPECIFICATIONS MAY BE USED AT THE OPTION OF THE CONTRACTOR.
4. WIDTH OF MATERIAL MAY VARY FROM MINIMUM DIMENSION BY INCREMENTS OF 4 OR 5 FEET.
5. FOR SOURCES OF APPROVED MATERIAL SEE VDOT'S APPROVED PRODUCTS LIST FOR ST'D. EC-2 MATERIAL.



ROAD AND BRIDGE STANDARDS

SHEET 1 OF 1

REVISION DATE

113.02

PROTECTIVE COVERING INSTALLATION CRITERIA

VIRGINIA DEPARTMENT OF TRANSPORTATION

SPECIFICATION REFERENCE

244
606

TYPICAL INSTALLATION AT END OF PIPE

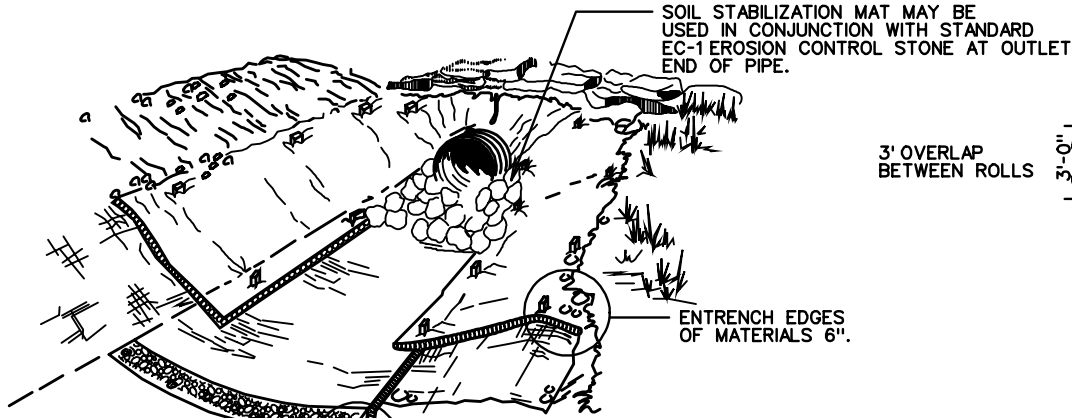

STAKING DETAIL

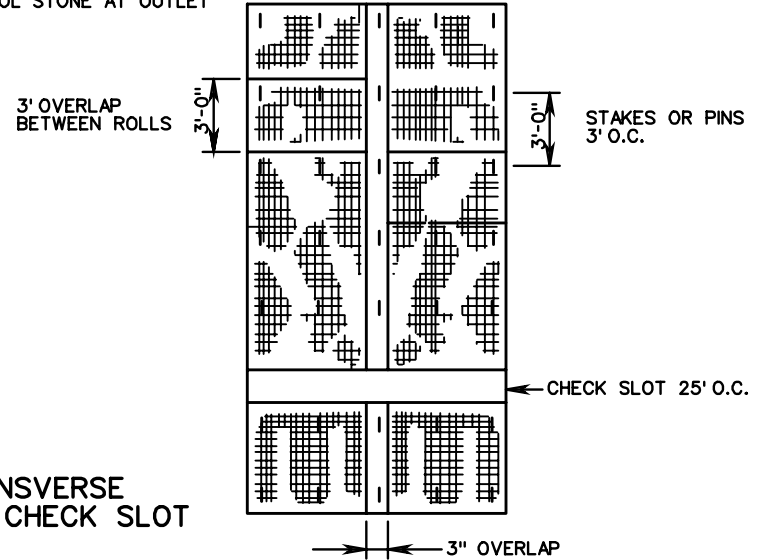

* TRANSVERSE CLOSED CHECK SLOT

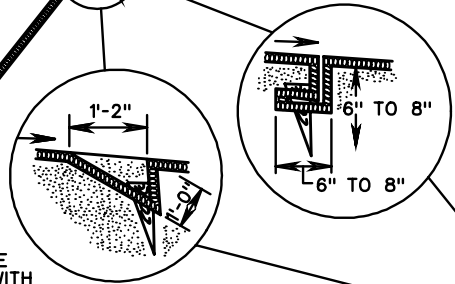

* TRANSVERSE CHECK SLOT TO BE CONSTRUCTED IN ACCORDANCE WITH THE MANUFACTURER'S RECOMMENDATION FOR PREFERRED INSTALLATION.

* TRANSVERSE OPEN CHECK SLOT

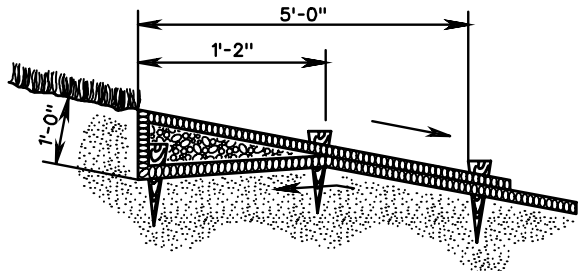

UPSTREAM AND DOWNSTREAM TERMINAL

V DITCH

NOTES:

1. STAKES SHALL BE WOOD OR METAL AS RECOMMENDED BY THE MANUFACTURER AND SHALL BE A MINIMUM OF 12" IN LENGTH. IN SANDY SOILS METAL STAKES A MINIMUM OF 18" IN LENGTH SHALL BE USED.
2. SOIL STABILIZATION MAT TYPE A AND B ARE TO BE IN ACCORDANCE WITH THE APPROVED PRODUCTS LIST.
3. SOIL STABILIZATION MAT SHOULD BE INSTALLED TO THE SHOULDER BREAK POINT OR EXISTING GROUND THEN EMBEDDED 6". MATERIAL ON BOTH SIDES OF THE DITCH SHALL BE INSTALLED TO THE SAME ELEVATIONS.
4. IF MORE THAN 3 LINES OF MATERIAL ARE REQUIRED PARALLEL TO THE C OF THE DITCH, MATERIAL SHALL BE INSTALLED PERPENDICULAR TO THE CENTER LINE OF THE DITCH, STARTING AT THE LOWEST C ELEVATION OF THE DITCH.
5. FOR SOURCES OF APPROVED MATERIALS SEE VDOT'S APPROVED PRODUCTS LIST FOR ST'D. EC-3, TYPE A OR B.

SPECIFICATION REFERENCE	244 606	<p>SOIL STABILIZATION MAT DITCH INSTALLATION TYPE A OR B</p> <p>VIRGINIA DEPARTMENT OF TRANSPORTATION</p>	<p>VDOT ROAD AND BRIDGE STANDARDS</p>	
			REVISION DATE	SHEET 1 OF 3 113.03

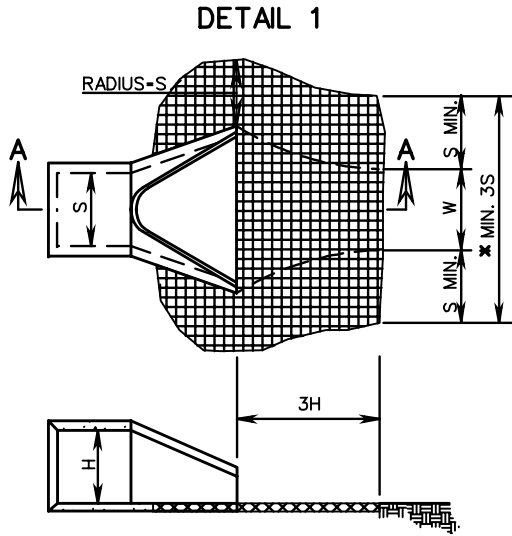

SECTION A-A

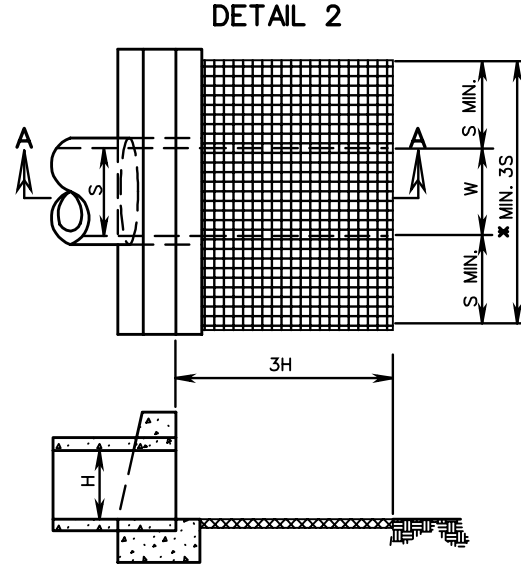

SECTION A-A

NOTES:

1. FOR MULTIPLE LINE INSTALLATIONS, DIMENSION S IS TO GOVERN THE PROTECTION OUTSIDE THE CHANNEL WIDTH (W).
 2. ON ANY INSTALLATION REQUIRING CULVERT OUTLET PROTECTION WHERE NO ENDWALL OR ENDSECTION IS SPECIFIED ON THE PLANS, CONSTRUCTION IS TO BE IN ACCORDANCE WITH DETAIL 2 SHOWN ABOVE.
 3. SOIL STABILIZATION MAT TYPE B SHALL BE USED FOR CULVERT OUTLET PROTECTION WHERE THE OUTLET VELOCITY IS 6 FPS OR LESS FOR THE DESIGN STORM AND THE TOTAL HYDRAULIC OPENING IS LESS THAN 7 SQUARE FEET. IF THE TOTAL HYDRAULIC OPENING IS 7 SQUARE FEET OR GREATER, OR THE DESIGN STORM OUTLET VELOCITY IS GREATER THAN 6 FPS USE STANDARD EC-1.
 4. S = DIAMETER OF CIRCULAR CULVERT OR SPAN FOR BOX, ELLIPTICAL OR ARCH CULVERT.
H = DIAMETER OF CIRCULAR CULVERT OR RISE/HEIGHT FOR BOX, ELLIPTICAL OR ARCH CULVERT.
- * USE TYPICAL SECTION SHOWN ON PLANS FOR SIDE SLOPE, BOTTOM WIDTH AND DEPTH OF CHANNEL OR MATCH EXISTING DITCH OR NATURAL GROUND.



ROAD AND BRIDGE STANDARDS

SHEET 2 OF 3

REVISION DATE

113.04

**SOIL STABILIZATION MAT
CULVERT OUTLET PROTECTION INSTALLATION**

VIRGINIA DEPARTMENT OF TRANSPORTATION

SPECIFICATION
REFERENCE

204
245
303
414

FILL SLOPE SECTION

DROP STD EC-3 MATERIAL VERTICALLY DOWNSLOPE

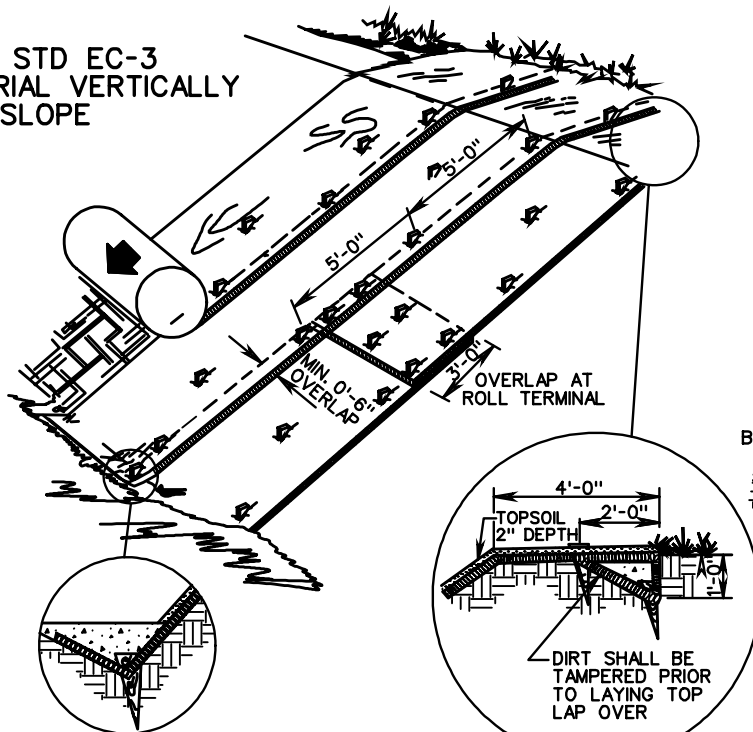

TOE OF FILL

MAINTAIN SLOPE ANGLE

BERM

TRENCH INTO BERM AND PROGRESS DOWNSLOPE

SLOPE LINING - WET SLOPE

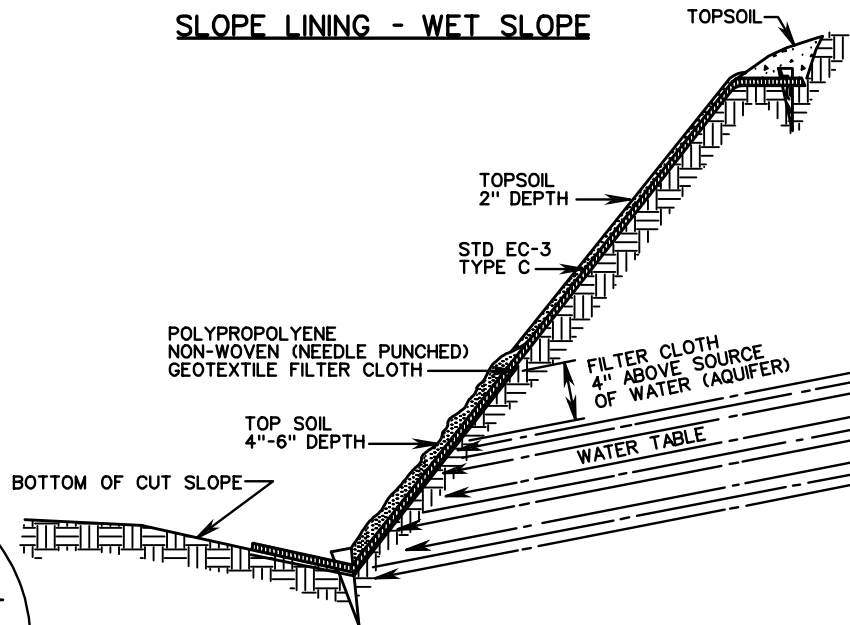

SLOPE LINING - DRY SLOPE

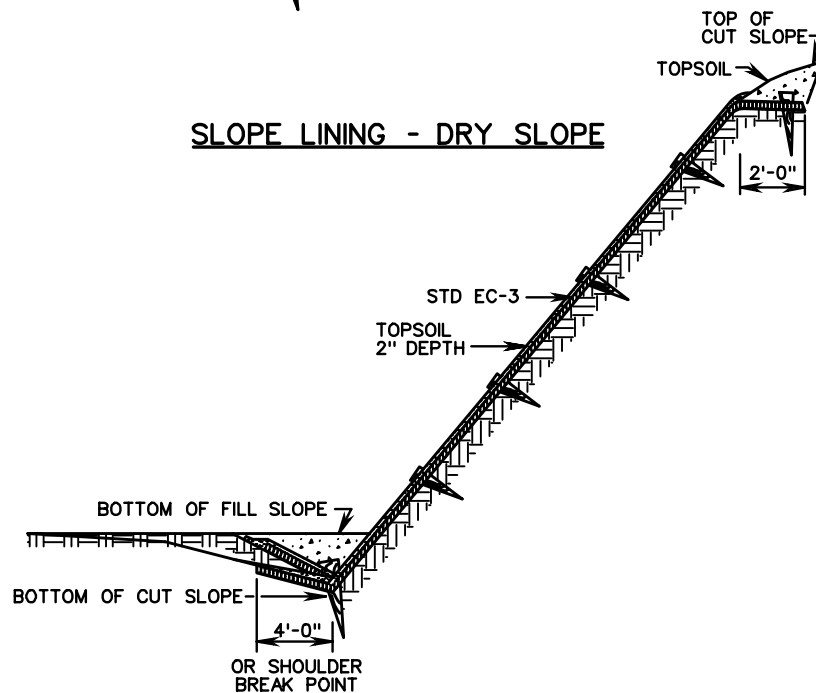

NOTE:

1. SLOPE SURFACE SHALL BE SMOOTH AND FREE OF ROCKS, LUMPS OF DIRT, GRASS, AND STICKS. MAT SHALL BE PLACED FLAT ON SURFACE FOR PROPER SOIL CONTACT.
2. STAKES SHALL BE WOOD OR METAL AS RECOMMENDED BY THE MANUFACTURER AND SHALL BE A MINIMUM OF 18 INCHES IN LENGTH.
3. BASIS OF PAYMENT SHALL BE SQUARE YARDS OF STANDARD EC-3 (TYPE C) IN PLACE.
4. SOIL STABILIZATION MAT TYPE C SHALL BE IN ACCORDANCE WITH THE APPROVED PRODUCT LIST.
5. TOPSOIL SHALL BE SPREAD TO A UNIFORM THICKNESS PRIOR TO APPLICATION OF SEED AND MULCH.
6. FOR SOURCES OF APPROVED MATERIALS SEE VDOT'S APPROVED PRODUCTS LIST FOR ST'D. EC-3, TYPE C MATERIALS.
7. SLOPES 1/2:1 AND FLATTER SHALL BE BACKFILLED WITH TOPSOIL AT 2 INCH DEPTH. SEED SHALL BE APPLIED TO THE TOPSOIL AND MULCHED WITH TYPE I MULCH.
8. SLOPES STEEPER THAN 1/2:1 SHALL BE SEEDED IMMEDIATELY PRIOR TO INSTALLATION OF ST'D. EC-3 TYPE C MATERIAL.

SPECIFICATION REFERENCE

244
606

**SOIL STABILIZATION MAT -
SLOPE INSTALLATION TYPE C**

VIRGINIA DEPARTMENT OF TRANSPORTATION

VDOT

ROAD AND BRIDGE STANDARDS

REVISION DATE

SHEET 3 OF 3

113.05

TYPICAL DETAIL FOR ROCK CHECK DAM TYPE I

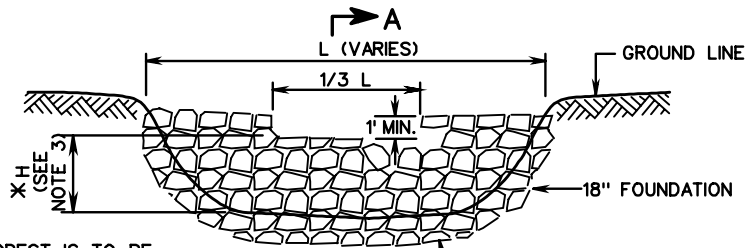

* HEIGHT (H) OF CREST IS TO BE 3'± IF CHANNEL OR SWALE IS DEEP ENOUGH OR AS DESIGNATED BY DESIGNER.

FRONT ELEVATION

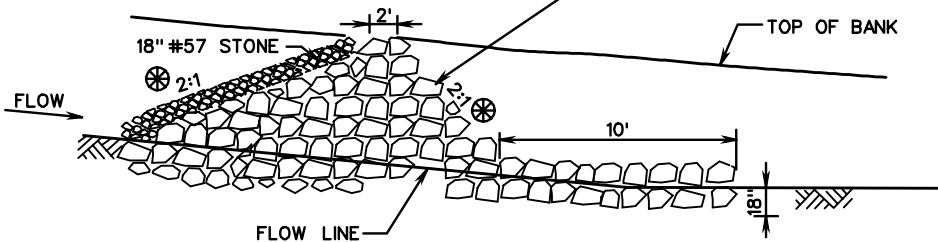

SECTION A-A

TYPICAL DETAIL FOR ROCK CHECK DAM TYPE II

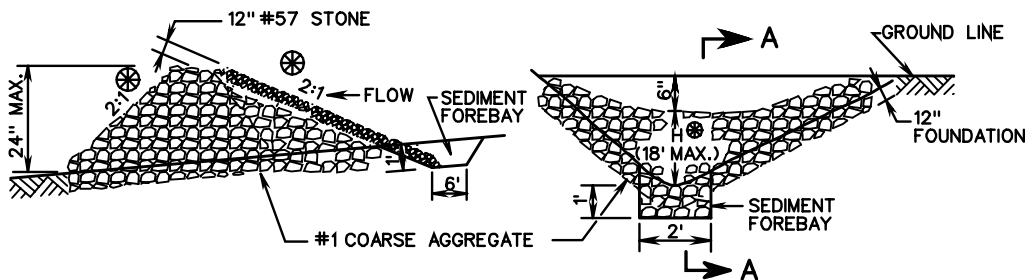

SECTION A-A

FRONT ELEVATION

SUGGESTED ROCK CHECK DAM SPACING

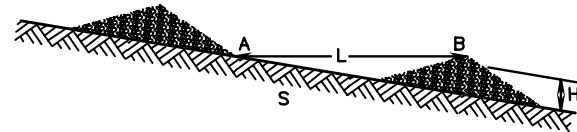

L = H/S WHERE:
 H = HEIGHT OF DAM CREST IN FEET
 S = CHANNEL SLOPE IN FT/FT
 L = CHECK DAM SPACING IN FEET; THE DISTANCE SUCH THAT POINTS A AND B ARE OF EQUAL ELEVATION

CHECK DAM SPACING, L TO BE DETERMINED FROM THE EQUATION. IN STEEP SLOPE AREAS THE CHECK DAM SPACING IS NOT TO BE LESS THAN 25'.

NOTES:

1. ROCK CHECK DAMS THAT ARE DESIGNATED ON THE PLANS AS A STORMWATER MANAGEMENT (SWM) ITEM ARE TO BE LEFT IN PLACE AS A PERMANENT INSTALLATION.
2. WHERE DRAINAGE AREAS EXCEED 1 ACRE OR DITCH GRADE EXCEEDS 3%, A TEMPORARY SEDIMENT FOREBAY SHALL BE INSTALLED WITH MINIMUM DIMENSIONS OF 12" DEPTH, 2' WIDTH AND 6' LENGTH.
3. IF CHECK DAMS IS LOCATED INSIDE CLEAR ZONE AND ADJACENT TO A TRAVELWAY, SLOPE FACING ON COMING TRAFFIC IS TO BE 6:1 AND MAXIMUM H IS TO BE 12".
4. ALTERNATIVE MATERIALS ON VDOT'S SPEL LIST MAY BE SUBSTITUTED AT NO ADDITIONAL COST TO THE DEPARTMENT.
5. SEE STANDARD EC-5 FOR DETAILS FOR ROCK CHECK DAMS IN ROADSIDE DITCHES
6. CHECK DAM SHALL NOT BE USED FOR LOCATIONS IN LIVE STREAM.



ROAD AND BRIDGE STANDARDS

SHEET 1 OF 1

REVISION DATE

113.06

ROCK CHECK DAMS TYPE I & II

VIRGINIA DEPARTMENT OF TRANSPORTATION

SPECIFICATION REFERENCE

107
303

TYPICAL DETAIL FOR TEMPORARY SILT FENCE/CHECK DAM AT TOE OF FILL

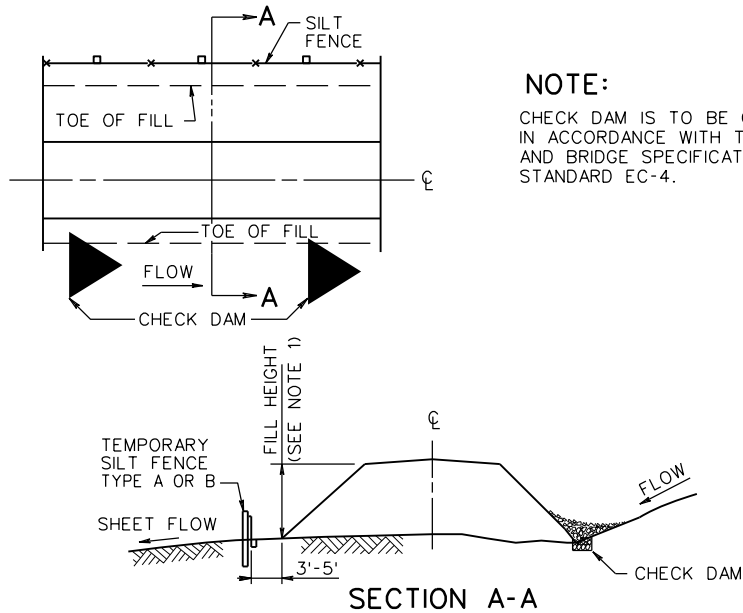

NOTE:
CHECK DAM IS TO BE CONSTRUCTED IN ACCORDANCE WITH THE ROAD AND BRIDGE SPECIFICATIONS, AND STANDARD EC-4.

TYPICAL DETAIL FOR TEMPORARY SILT FENCE/CHECK DAM AT CULVERT

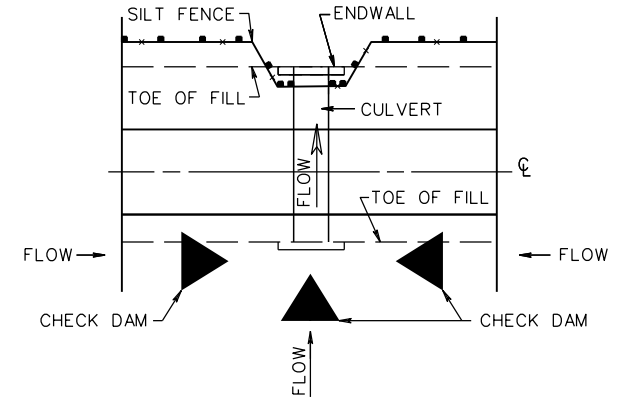

NOTE:
CHECK DAM IS TO BE CONSTRUCTED IN ACCORDANCE WITH THE ROAD AND BRIDGE SPECIFICATIONS, AND STANDARD EC-4.

NOTES FOR SILT FENCE TYPE A & B:

1. USE OF TYPE A SILT FENCE IS LIMITED TO A FILL HEIGHT OF 20 FEET OR LESS. TYPE B SILT FENCE MUST BE USED WHERE THE FILL HEIGHT EXCEEDS 20 FEET.
2. ALL POSTS SHALL BE DRIVEN 24" MIN. INTO THE GROUND AND SHALL EXTEND 6" ABOVE THE FILTER FABRIC (TYPE A) OR WIRE FENCE (TYPE B). WOODEN POSTS SHALL BE OAK AND HAVE MIN. DIMENSIONS OF 2" BY 2". STEEL POSTS SHALL HAVE A MINIMUM WEIGHT OF 1.33 POUNDS PER LINEAR FOOT.
3. GEOTEXTILE FABRIC SHALL BE EMBEDDED 12" INTO THE GROUND (6" VERTICALLY AND 6" HORIZONTALLY ALONG THE BOTTOM OF TRENCH) AS SHOWN IN DETAILS A(2) & B(2) ON SHEETS 2 AND 3.
4. SLICING IS AN APPROVED ALTERNATIVE TO TRENCHING FOR ANCHORING THE GEOTEXTILE FABRIC INTO THE GROUND SHOWN IN DETAILS A(2) & B(2) ON SHEETS 2 AND 3. SLICING SHALL BE ACCOMPLISHED IN ACCORDANCE WITH SECTION 303 OF THE ROAD AND BRIDGE SPECIFICATIONS.
5. WHEN TWO SEPARATE SECTIONS OF GEOTEXTILE FABRIC ADJOIN EACH OTHER, THEY SHALL OVERLAP BY 6" AND BE DOUBLE FOLDED.
6. GEOTEXTILE FABRIC SHALL BE FASTENED SECURELY TO THE POSTS (TYPE A & B) AND WIRE FENCE (TYPE B ONLY). THE ATTACHMENTS TO THE WIRE FENCE SHALL BE MADE WITH TIES SPACED EVERY 24" HORIZONTALLY AT BOTH THE TOP AND VERTICAL MIDPOINT OF THE GEOTEXTILE FABRIC.
7. WIRE FENCE (TYPE B ONLY) SHALL BE FASTENED SECURELY TO THE FENCE POSTS WITH WIRE TIES AND EMBEDDED A MINIMUM OF 2" IN THE GROUND.
8. WIRE FENCE (TYPE B ONLY) SHALL BE A MINIMUM OF 14 GAUGE WELDED WIRE WITH A MESH SPACING OF 2" BY 4". ALTERNATIVE MESH SPACING MAY BE APPROVED BY THE ENGINEER, BUT MUST BE NO MORE THAN 6" BY 6".
9. FOR AREAS REQUIRING TYPE B SILT FENCE, A MINIMUM LENGTH OF 100 LINEAR FEET SHALL BE INSTALLED.
10. AS AN ALTERNATIVE TO UTILIZING TYPE B SILT FENCE, TWO ROWS OF TYPE A SILT FENCE MAY BE PLACED PARALLEL TO EACH OTHER WITH 3' TO 5' BETWEEN THE TWO ROWS. THIS OPTION MAY BE USED AT ALL LOCATIONS SPECIFYING TYPE B SILT FENCE UNLESS OTHERWISE PROHIBITED BY THE PLANS. SEE DETAIL ON SHEET 3 (BOTTOM RIGHT).
11. MATERIALS FOR ALL SILT FENCE SHALL CONFORM TO THE REQUIREMENTS OF SECTION 242 OF THE VDOT ROAD & BRIDGE SPECIFICATIONS.

SPECIFICATION REFERENCE

107
242
245
303

A COPY OF THE ORIGINAL SEALED AND SIGNED DRAWING IS ON FILE IN THE CENTRAL OFFICE.

TEMPORARY SILT BARRIERS
SILT FENCE (TYPE A & B) AND BRUSH BARRIER

VIRGINIA DEPARTMENT OF TRANSPORTATION

VDOT

ROAD AND BRIDGE STANDARDS

REVISION DATE

08/14

SHEET 1 OF 4

113.07

SILT FENCE TYPE A

SEE SHEET 1 FOR NOTES

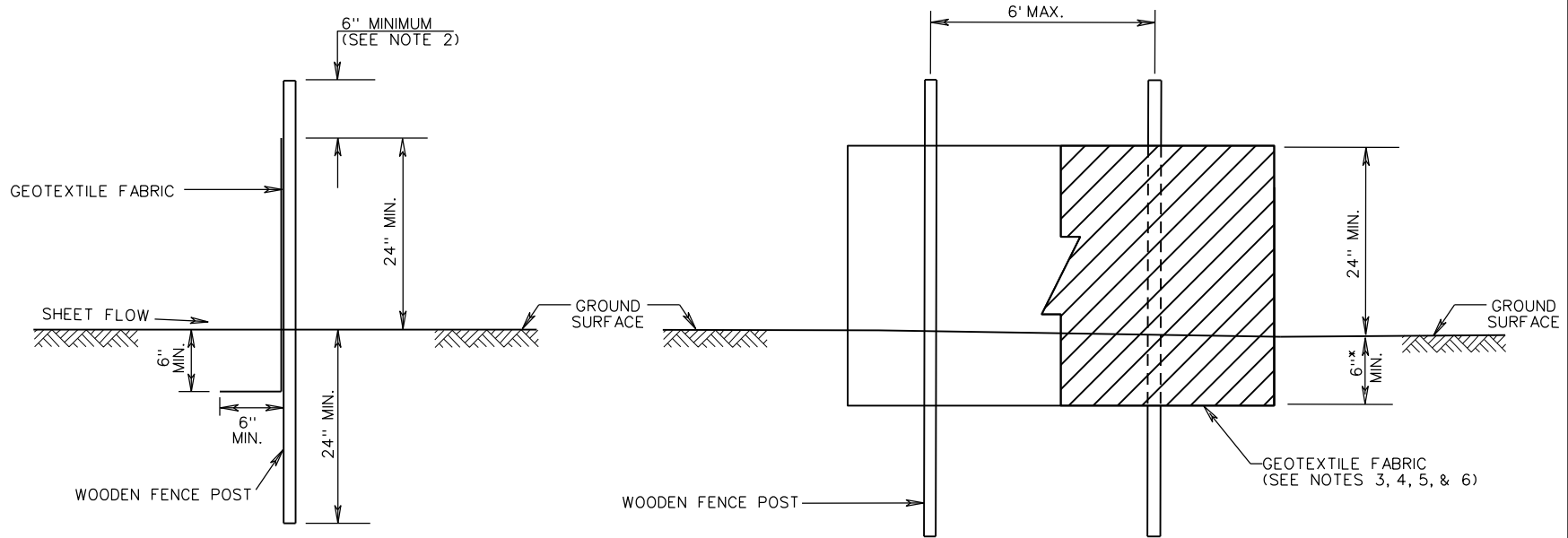

SECTION VIEW

PROFILE VIEW

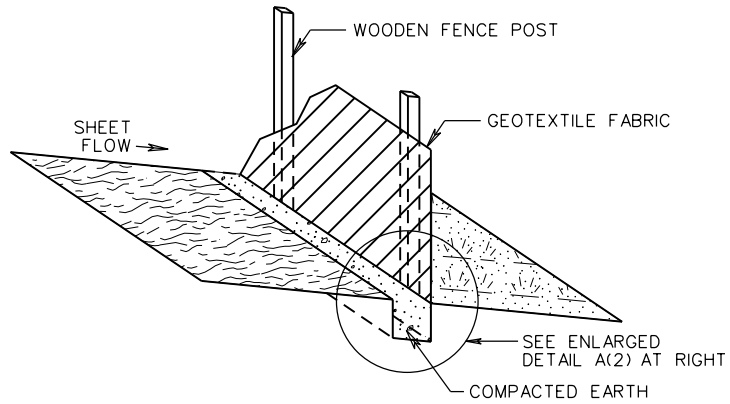

DETAIL A(1)

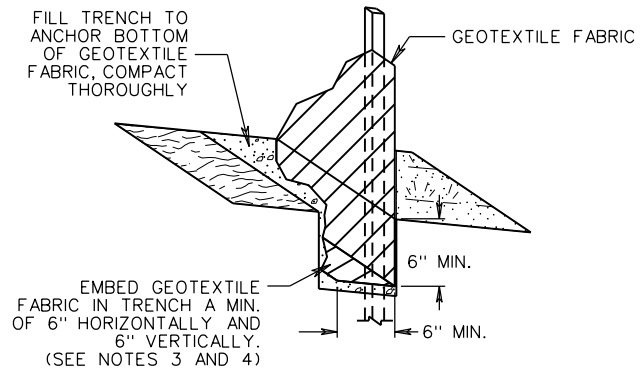

DETAIL A(2)



ROAD AND BRIDGE STANDARDS

A COPY OF THE ORIGINAL SEALED AND SIGNED DRAWING IS ON FILE IN THE CENTRAL OFFICE.

TEMPORARY SILT BARRIERS
SILT FENCE (TYPE A & B) AND BRUSH BARRIER

SPECIFICATION REFERENCE

SHEET 2 OF 4

REVISION DATE

107
242
245
303

113.07A

08/14

VIRGINIA DEPARTMENT OF TRANSPORTATION

SILT FENCE TYPE B

SEE SHEET 1 FOR NOTES

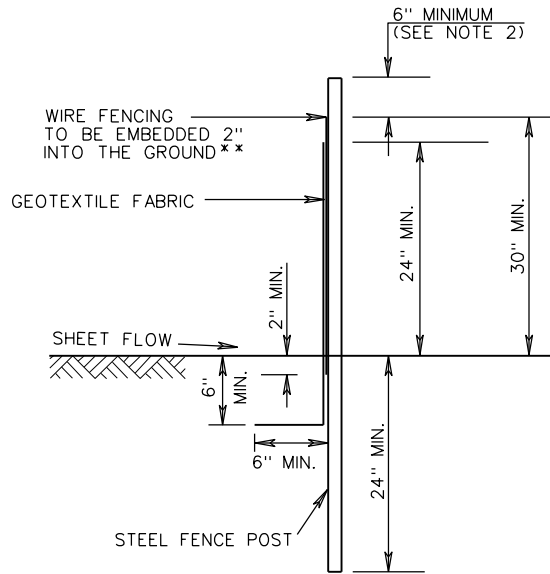

SECTION VIEW

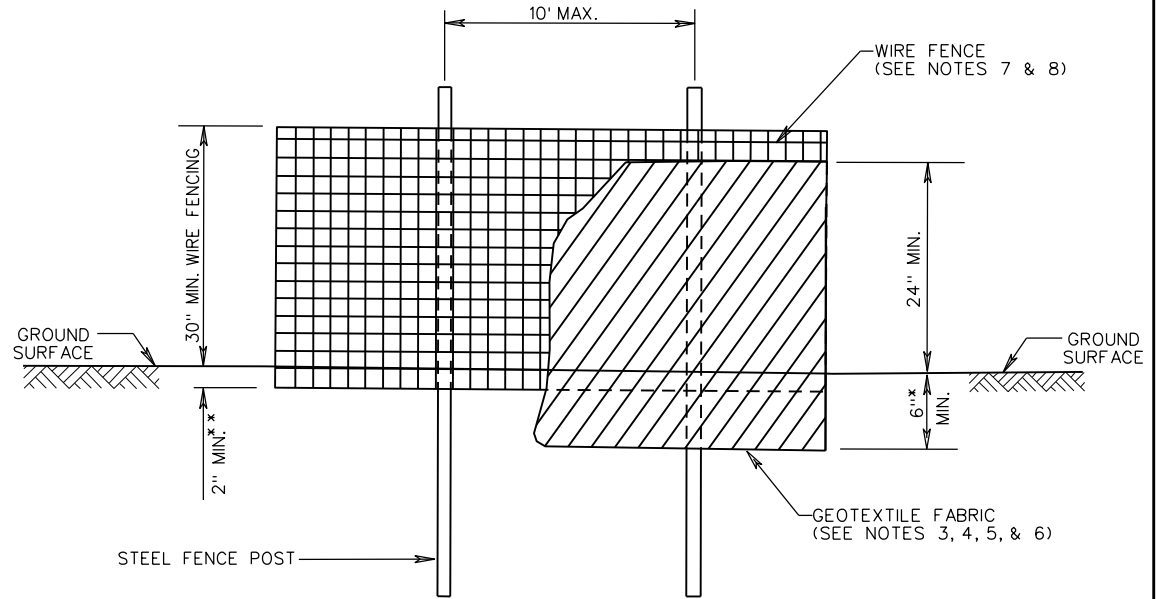

PROFILE VIEW

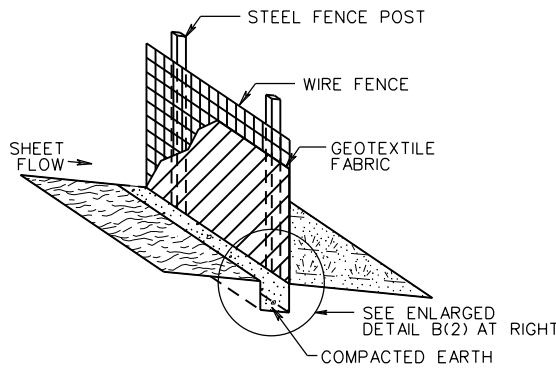

DETAIL B(1)

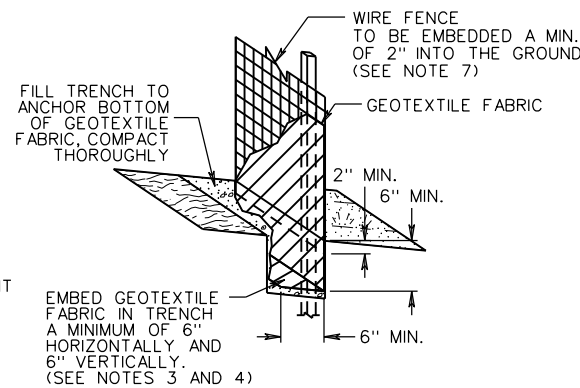

DETAIL B(2)

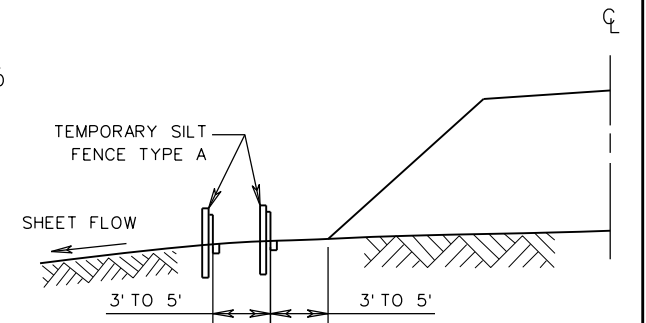

ALTERNATIVE SILT FENCE TYPE B
(SEE NOTE 10)

SPECIFICATION REFERENCE

- 107
- 242
- 245
- 303

A COPY OF THE ORIGINAL SEALED AND SIGNED DRAWING IS ON FILE IN THE CENTRAL OFFICE.

TEMPORARY SILT BARRIERS
SILT FENCE (TYPE A & B) AND BRUSH BARRIER
VIRGINIA DEPARTMENT OF TRANSPORTATION

VDOT

ROAD AND BRIDGE STANDARDS

REVISION DATE

08/14

SHEET 3 OF 4

113.07B

SILT BARRIERS
TYPICAL DETAIL FOR BRUSH BARRIER
 (TO BE USED AT ALL APPLICABLE LOCATIONS)

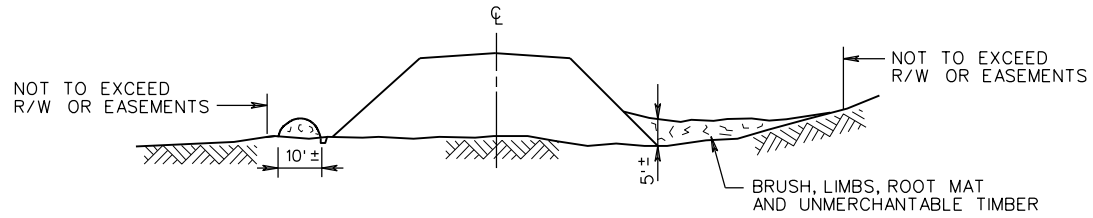
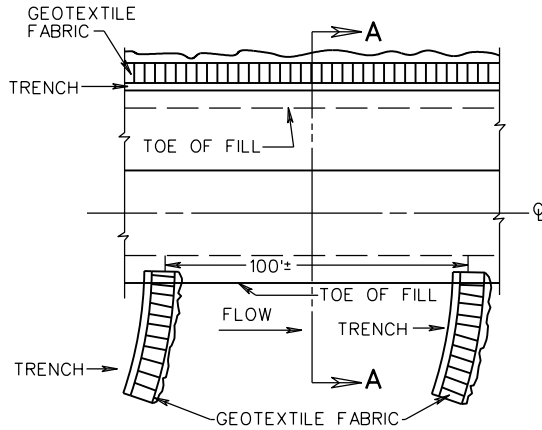

SECTION A-A

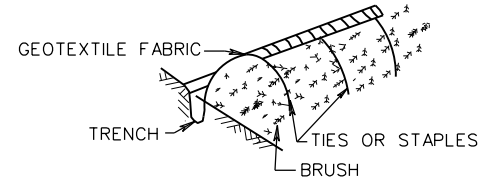

BACK ISOMETRIC

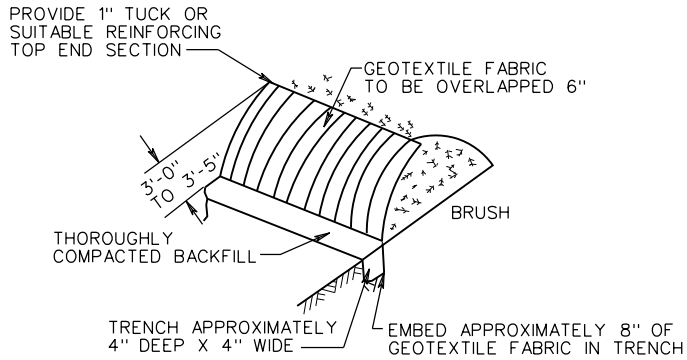

FRONT ISOMETRIC

NOTES:

- BRUSH BARRIERS SHALL BE CONSTRUCTED AT LOCATION SHOWN ON THE PLANS OR AS DIRECTED BY THE ENGINEER. BRUSH SHALL BE PILED AGAINST EXISTING TREES TO PREVENT MOVEMENT OF BARRIER. BRUSH SHALL BE PILED AS TIGHTLY AS POSSIBLE AND WEIGHTED DOWN BY UNMERCHANTABLE LOGS.
- GEOTEXTILE FABRIC CONFORMING TO THE ROAD AND BRIDGE SPECIFICATIONS SHALL BE INSTALLED AS DETAILED ABOVE. GEOTEXTILE FABRIC MAY ALSO BE ATTACHED TO EXISTING FENCES WHEN SPECIFIED ON THE PLANS OR DIRECTED BY THE ENGINEER.
- NO BRUSH WILL BE DESTROYED OR REMOVED FROM THE PROJECT UNTIL ALL BRUSH SILT BARRIERS ARE IN PLACE AND HAVE BEEN INSPECTED AND APPROVED BY THE ENGINEER.
- DIMENSIONS SHOWN ARE APPROXIMATE ONLY.



ROAD AND BRIDGE STANDARDS

SHEET 4 OF 4

REVISION DATE

113.08

08/14

TEMPORARY SILT BARRIERS
SILT FENCE (TYPE A & B), AND BRUSH BARRIER

VIRGINIA DEPARTMENT OF TRANSPORTATION

SPECIFICATION
 REFERENCE

107
 303

INLET PROTECTION (TYPE A)

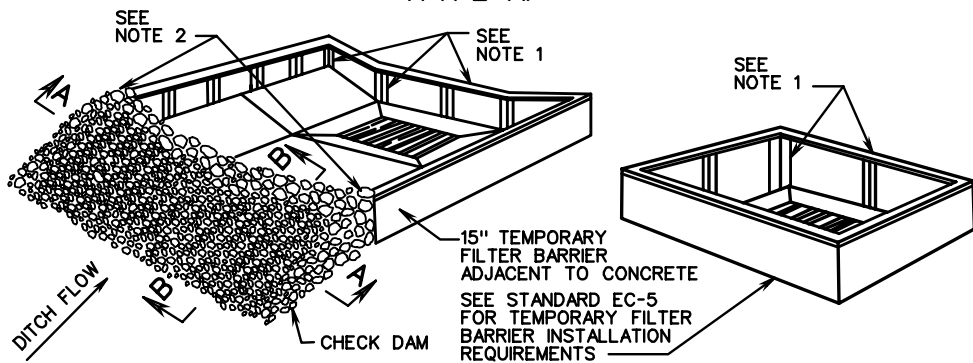

TYPICAL TREATMENT FOR DROP INLET WITH CONCRETE GUTTER

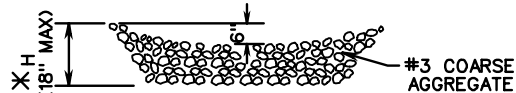

SECTION A-A

* IF CHECK DAM IS LOCATED INSIDE CLEAR ZONE AND ADJACENT TO A TRAVELWAY, SLOPE FACING ON COMING TRAFFIC IS TO BE 6:1 AND MAXIMUM H IS TO BE 12".

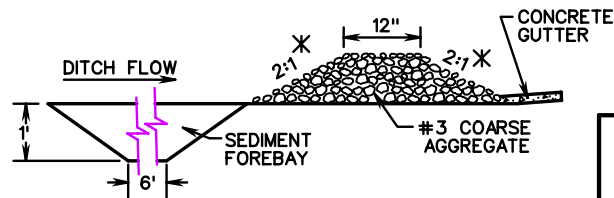

SECTION B-B

NOTES

1. POSTS AND TOP RAIL SHALL BE A NOMINAL 2 1/2" X 2 1/2" OR A 3" DIA. NO. 2 SOUTHERN PINE, A NOMINAL 2" X 2" OAK, OR STEEL HAVING A MIN. WEIGHT OF 1.25 LBS. PER LINEAR FOOT AND A MIN. LENGTH OF 5' FOR TEMPORARY SILT FENCES.
2. END OF FILTER BARRIER TO BE EMBEDDED INTO AGGREGATE.
3. IF A DROP INLET IS LOCATED IN A SAG IN THE DITCH GRADE, A CHECK DAM IS REQUIRED FOR EACH SIDE OF THE INLET THAT RECEIVES DITCH FLOW.
4. WHERE DRAINAGE AREAS EXCEED ONE ACRE OR DITCH GRADE EXCEEDS 3%, A TEMPORARY SEDIMENT FOREBAY SHALL BE INSTALLED WITH MINIMUM DIMENSIONS OF 12" DEPTH, 2' WIDTH AND 6' LENGTH.

TYPICAL TREATMENT FOR DROP INLET WITHOUT CONCRETE GUTTER

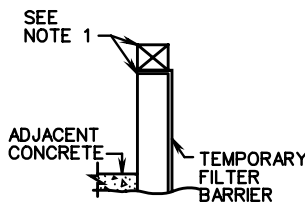

INLET PROTECTION (TYPE B)

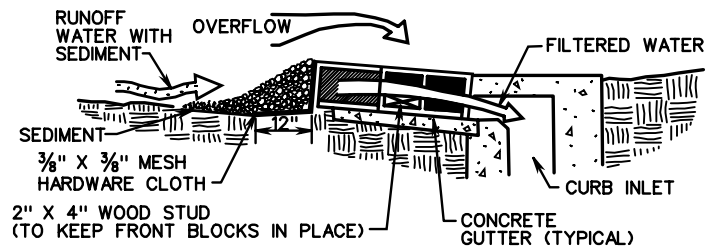
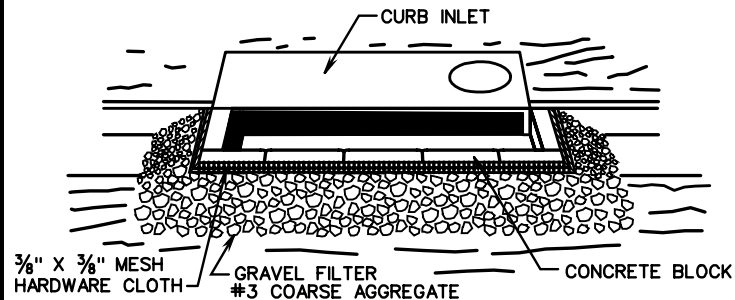

SECTION VIEW

SPECIFIC APPLICATION

THIS METHOD OF INLET PROTECTION IS APPLICABLE AT CURB INLETS WHERE AN OVERFLOW CAPABILITY IS NECESSARY TO PREVENT EXCESSIVE PONDING IN FRONT OF THE STRUCTURE.

NOTE:

GEOTEXTILE PRODUCTS DESIGNED TO BE INSERTED INTO GRATED DROP INLETS OR DESIGNED TO COVER THE SLOTS OF SLOT DROP INLETS, THAT HAVE BEEN APPROVED FOR USE ON VDOT PROJECTS AND ARE FOUND ON VDOT'S SPEL LIST, MAY BE SUBSTITUTED FOR THE DROP INLET PROTECTION DEVICES DETAILED HEREON.

SPECIFICATION REFERENCE

107
242
303

INLET PROTECTION (TYPE A AND B)

VIRGINIA DEPARTMENT OF TRANSPORTATION

VDOT

ROAD AND BRIDGE STANDARDS

REVISION DATE

SHEET 1 OF 2

113.09

TYPICAL DETAIL FOR INSTALLATION OF TEMPORARY FILTER BARRIER/SILT FENCE/CHECK DAM AT CULVERT

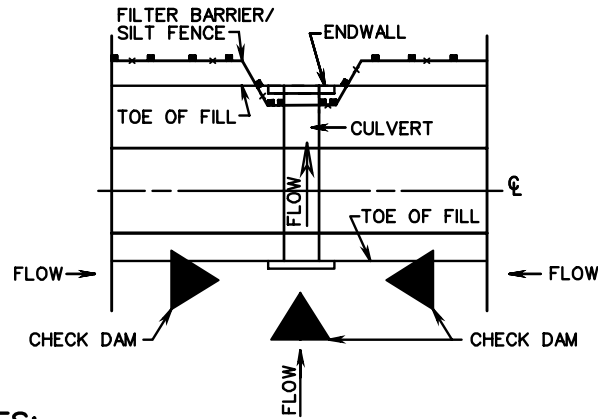

NOTES:

1. IF ANY PORTION OF FILL IS GREATER THAN 5', SILT FENCE IS REQUIRED. IF FILL HEIGHT IS LESS THAN 5', FILTER BARRIER IS REQUIRED.
2. ROCK CHECK DAM IS TO BE CONSTRUCTED IN ACCORDANCE WITH THE ROAD AND BRIDGE SPECIFICATIONS, AND STANDARD EC-4.
3. FILTER BARRIER/SILT FENCE IS TO BE INSTALLED IN ACCORDANCE WITH THE ROAD AND BRIDGE SPECIFICATIONS, AND STANDARD EC-5.

* INSTALLATION DETAIL ONLY - ROCK CHECK DAMS, FILTER BARRIER, AND SILT FENCE TO BE PAID FOR IN ACCORDANCE WITH THE ROAD AND BRIDGE SPECIFICATIONS.



ROAD AND BRIDGE STANDARDS

SHEET 2 OF 2

REVISION DATE

113.10

INLET PROTECTION
(TYPE C)

VIRGINIA DEPARTMENT OF TRANSPORTATION

SPECIFICATION
REFERENCE

107
242
303

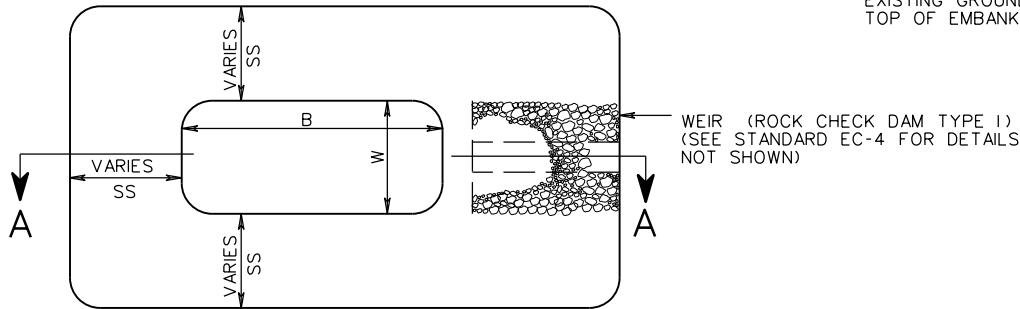

PLAN VIEW OF TEMPORARY SEDIMENT TRAP

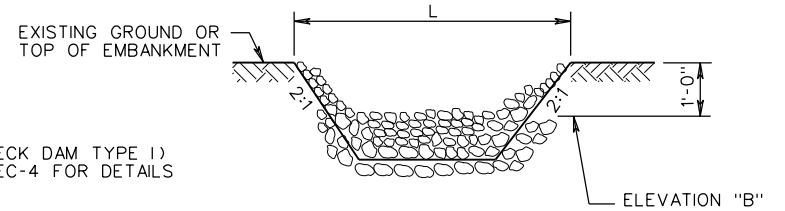

TYPICAL SECTION THRU WEIR
(ROCK CHECK DAM TYPE 1)

NOTES:

1. CHECK DAM IS SHOWN FOR ILLUSTRATION ONLY AND IS NOT INCLUDED IN PAYMENT FOR SEDIMENT TRAP.
2. THE SEDIMENT STORAGE VOLUME SHALL BE 134 CUBIC YARDS/ACRE OF TOTAL CONTRIBUTING DRAINAGE AREA AND SHALL CONSIST OF HALF IN THE FORM OF WET STORAGE AND HALF IN THE FORM OF DRY STORAGE.
3. SEE PLANS FOR DIMENSIONS AND ELEVATIONS.

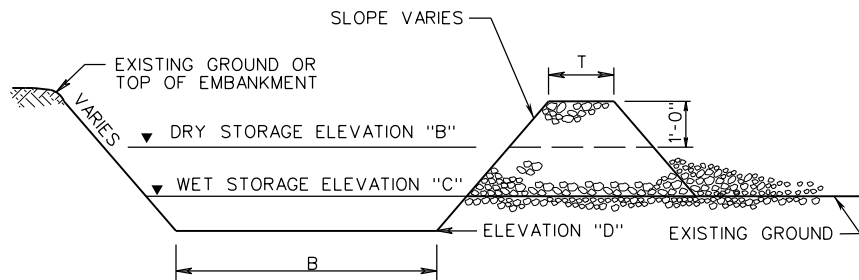

TYPICAL SECTION (A-A) THRU
TEMPORARY SEDIMENT TRAP

SPECIFICATION
REFERENCE

107
303

TYPICAL SEDIMENT TRAP

VIRGINIA DEPARTMENT OF TRANSPORTATION

VDOT

ROAD AND BRIDGE STANDARDS

REVISION DATE

01/13

SHEET 1 OF 1

113.11

TYPICAL DEWATERING BASIN

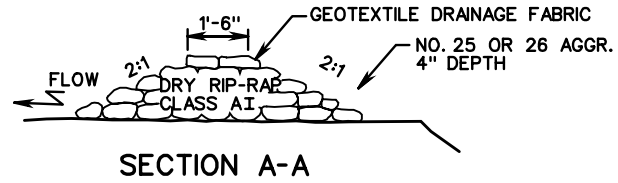
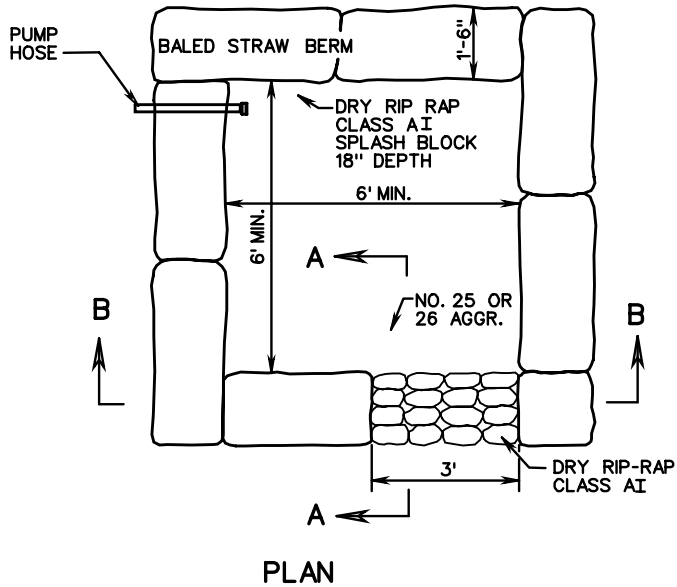

* GEOTEXTILE DRAINAGE FABRIC TO COVER INSIDE FACE OF BALED STRAW BERM.

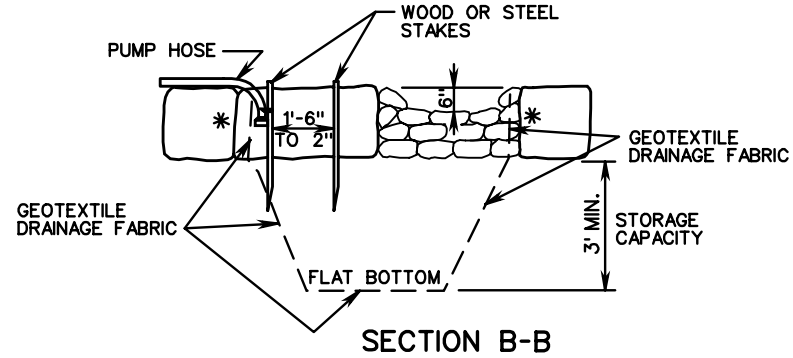

NOTES:

1. DEWATERING BASIN SIZE SHALL BE DETERMINED BY THE FORMULA $16 \times \text{GAL./MIN. OF PUMP} = \text{CU. FT. OF STORAGE CAPACITY}$.
2. THIS WORK SHALL CONSIST OF THE CONSTRUCTION OF A DEWATERING BASIN FOR THE PURPOSE OF RECEIVING SEDIMENT-LADENED WATER PUMPED FROM A CONSTRUCTION SITE TO ALLOW FOR FILTRATION BEFORE IT REENTERS THE WATERWAY. PUMPING INTO THESE BASINS SHALL CEASE WHEN THE FLOW FROM THE BASIN BECOMES SEDIMENT-LADENED.
3. SURFACE WATER FLOW SHALL BE DIVERTED AROUND THIS DEVICE.
4. THE OUTFALL FROM THE BASIN(S) SHALL HAVE A STABILIZED CONVEYANCE TO RECEIVING WATERS.
5. ONCE THE DEWATERING BASIN BECOMES FILLED TO HALF OF THE STORAGE CAPACITY, ACCUMULATED SEDIMENT SHALL BE REMOVED AND DISPOSED OF IN AN APPROVED DISPOSAL AREA OUTSIDE OF THE 100-YEAR FLOODPLAIN UNLESS OTHERWISE APPROVED ON THE PLANS.
6. SEDIMENT CONTROL DEVICES ARE TO REMAIN IN PLACE UNTIL ALL DISTURBED AREAS ARE STABILIZED AND THE ENGINEER APPROVES THEIR REMOVAL. GROUND CONTOURS SHALL BE RETURNED TO THEIR ORIGINAL CONDITION UNLESS SPECIFICALLY APPROVED OTHERWISE BY THE ENGINEER.
7. SYNTHETIC PRODUCTS THAT HAVE BEEN APPROVED FOR USE ON VDOT PROJECTS AND FOUND ON VDOT'S SPEL LIST MAY BE USED IN LIEU OF THIS DESIGN. HOWEVER, VDOT WILL ONLY COMPENSATE THE CONTRACTOR UP TO THE BID PRICE PER EACH AT EACH SITE.

TYPICAL SYNTHETIC PRODUCT

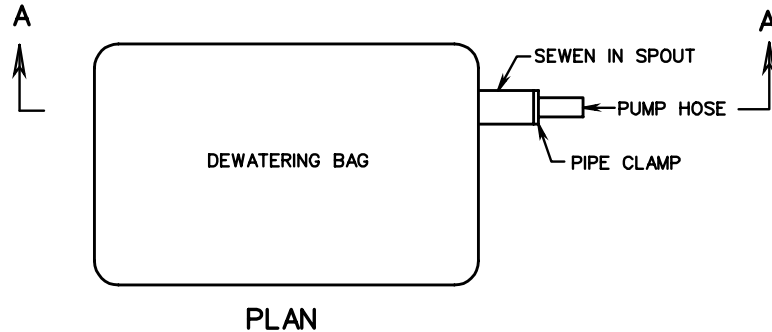
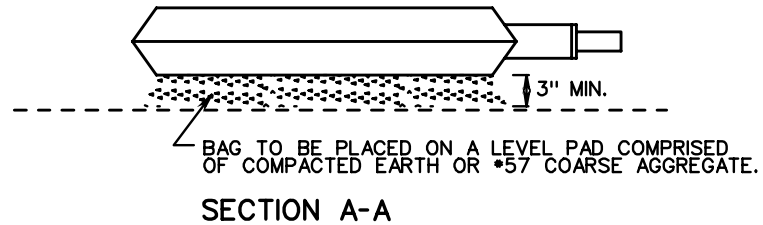

ROAD AND BRIDGE STANDARDS

SHEET 1 OF 1

REVISION DATE

113.12

DEWATERING BASIN

VIRGINIA DEPARTMENT OF TRANSPORTATION

SPECIFICATION REFERENCE

107
303

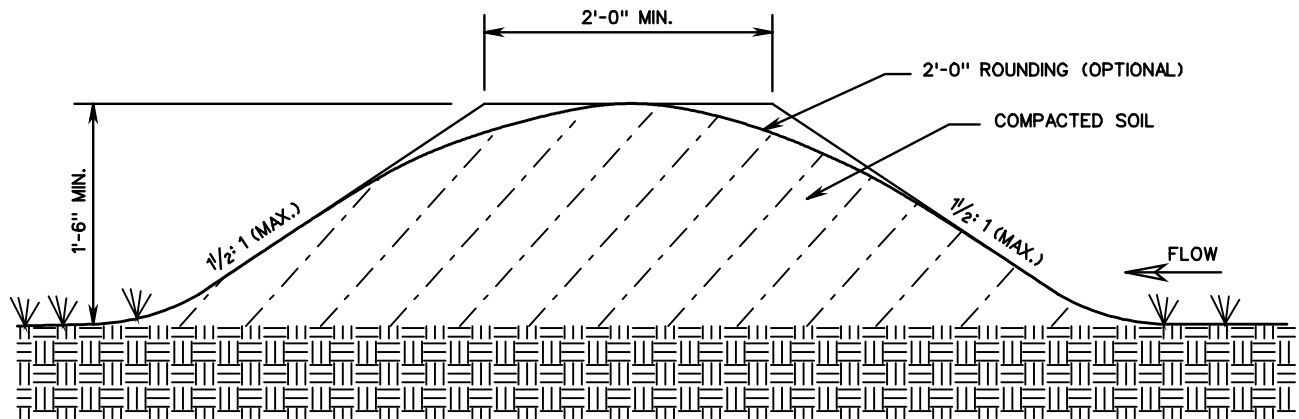

TEMPORARY DIVERSION DIKE

NOTE:

1. THE CHANNEL CREATED BEHIND THE DIKE SHALL HAVE A POSITIVE GRADE TO A STABILIZED OUTLET. THE CHANNEL SHALL BE STABILIZED, AS NECESSARY, TO PREVENT EROSION.
2. TEMPORARY DIVERSION DIKE WILL BE MEASURED AND PAID FOR IN ACCORDANCE WITH SECTION 303 OF THE SPECIFICATIONS.

<p>SPECIFICATION REFERENCE</p>	<h2>TEMPORARY DIVERSION DIKE</h2>	<p>VDOT ROAD AND BRIDGE STANDARDS</p>				
<p>303</p>	<p>VIRGINIA DEPARTMENT OF TRANSPORTATION</p>	<table border="1" style="width: 100%;"> <tr> <td style="width: 50%;">REVISION DATE</td> <td style="width: 50%;">SHEET 1 OF 1</td> </tr> <tr> <td colspan="2" style="text-align: center;">113.13</td> </tr> </table>	REVISION DATE	SHEET 1 OF 1	113.13	
REVISION DATE	SHEET 1 OF 1					
113.13						

TEMPORARY BERM & SLOPE DRAIN

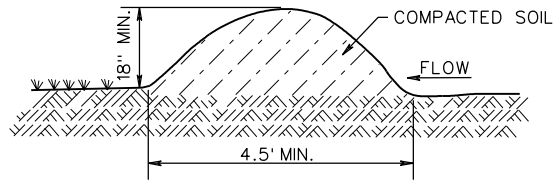
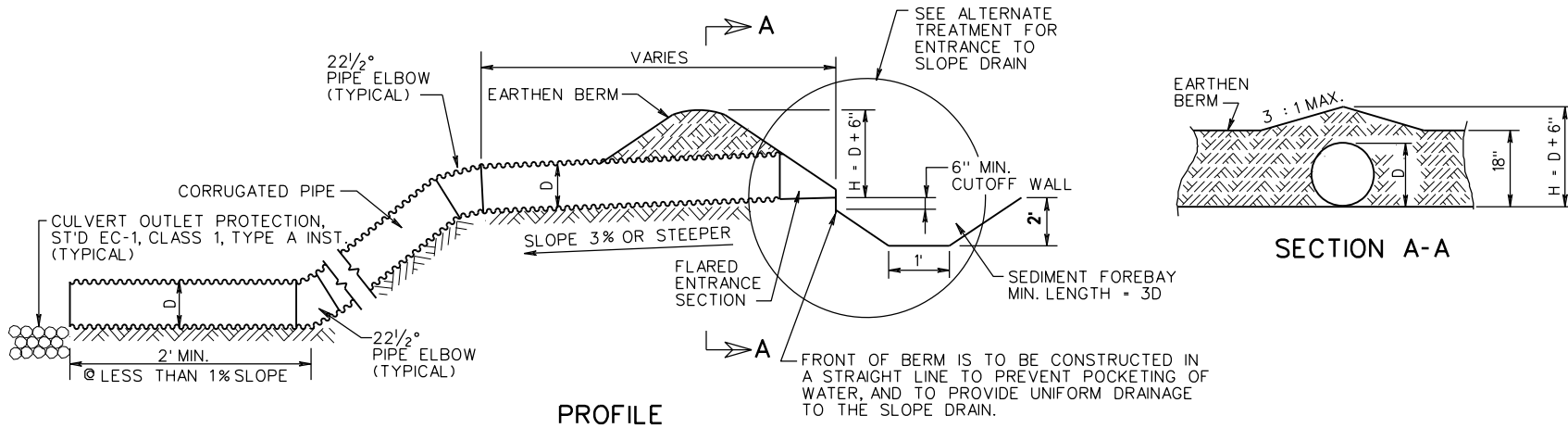

EARTHEN BERM SHALL BE INSTALLED IN ACCORDANCE WITH THE PLANS AND SPECIFICATIONS OR AS DIRECTED BY THE ENGINEER.

SIZE OF SLOPE DRAIN	
MAXIMUM DRAINAGE AREA (ACRES)	MINIMUM PIPE DIAMETER, D (IN.)
0.5	12
1.5	18
2.5	21
3.0	24

NOTES

1. SLOPE DRAIN SHALL BE SECURELY STAKED TO THE SLOPE, AT 10' (OR LESS) INTERVALS.
2. THE SLOPE DRAIN SECTIONS SHALL BE SECURELY FASTENED TOGETHER AND HAVE WATER TIGHT FITTINGS.

ALTERNATE ENTRANCE TREATMENT

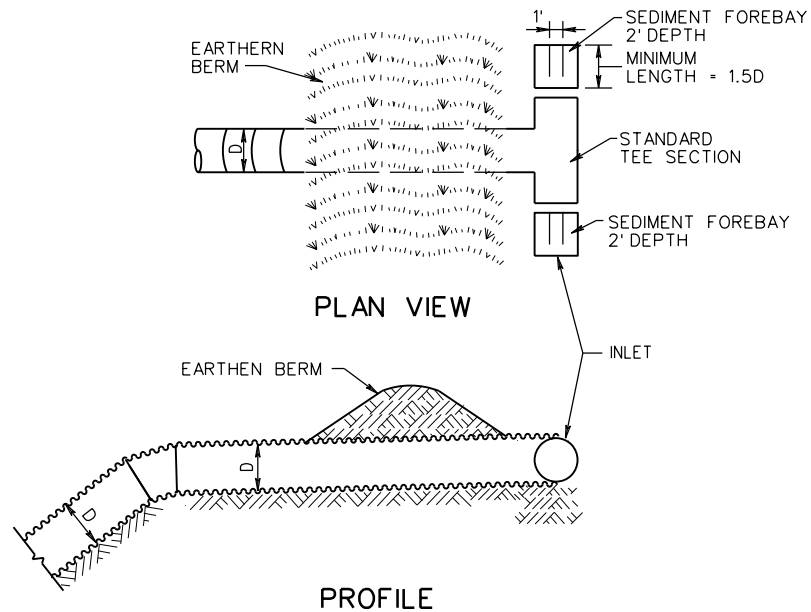

ROAD AND BRIDGE STANDARDS

TEMPORARY BERM & SLOPE DRAIN

SPECIFICATION REFERENCE

SHEET 1 OF 1

REVISION DATE

VIRGINIA DEPARTMENT OF TRANSPORTATION

113.14

01/13

107
303

MINIMUM REQUIREMENTS FOR STABILIZED CONSTRUCTION ENTRANCE

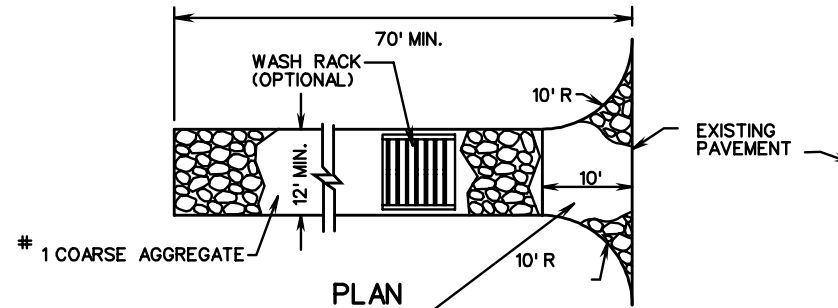

6" MINIMUM DEPTH #1 COARSE AGGREGATE, WITH MINIMUM 10' CLOSEST TO ROADWAY CAPPED WITH 4" MINIMUM DEPTH #68 OR #78 AGGREGATE, AS DIRECTED BY THE ENGINEER.

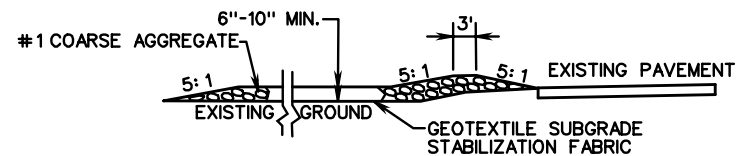

PROFILE

1. SURFACE WATER SHALL BE PIPED UNDER THE CONSTRUCTION ENTRANCE. IF PIPING IS IMPRACTICAL, A MOUNTABLE BERM WITH 5:1 SLOPES WILL BE PERMITTED.
2. THE ENTRANCE SHALL BE MAINTAINED IN A CONDITION WHICH WILL PREVENT TRACKING OR FLOWING OF SEDIMENT ONTO PUBLIC RIGHT OF WAY. THIS MAY REQUIRE PERIODIC TOP DRESSING WITH ADDITIONAL STONE AS CONDITIONS DEMAND AND REPAIR AND/OR CLEANOUT OF ANY MEASURES USED TO TRAP SEDIMENT. ALL SEDIMENT SPILLED, DROPPED, WASHED OR TRACKED ONTO PUBLIC RIGHT OF WAY SHALL BE REMOVED IMMEDIATELY.
3. WHEELS SHALL BE CLEANED TO REMOVE SEDIMENT PRIOR TO ENTRANCE ONTO PUBLIC RIGHT OF WAY. WHEN WASHING IS REQUIRED, IT SHALL BE DONE ON AN AREA STABILIZED WITH STONE AND WHICH DRAINS INTO AN APPROVED SEDIMENT TRAPPING DEVICE.
4. PERIODIC INSPECTION AND NEEDED MAINTENANCE SHALL BE PROVIDED AFTER HEAVY USE AND EACH RAIN.

SPECIFICATION REFERENCE

107
303

STABILIZED CONSTRUCTION ENTRANCE

VIRGINIA DEPARTMENT OF TRANSPORTATION

VDOT

ROAD AND BRIDGE STANDARDS

REVISION DATE

SHEET 1 OF 1

113.15

TYPICAL SECTION
TEMPORARY DIVERSION CHANNEL
AND ACCEPTABLE LININGS

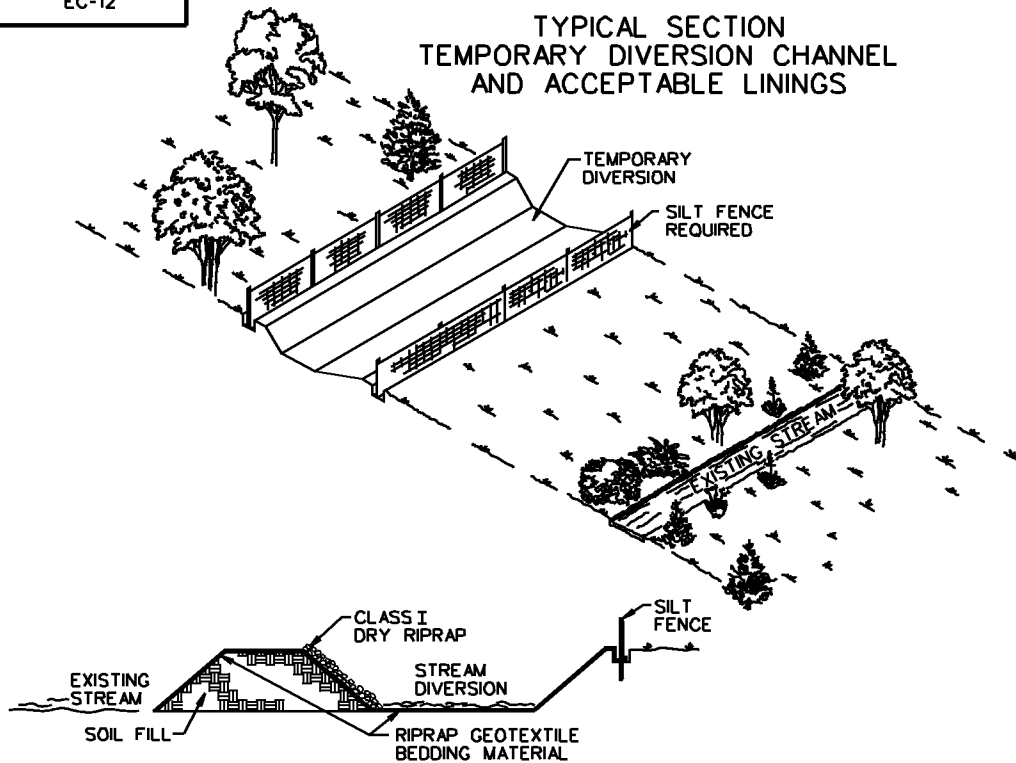

DAM DETAIL

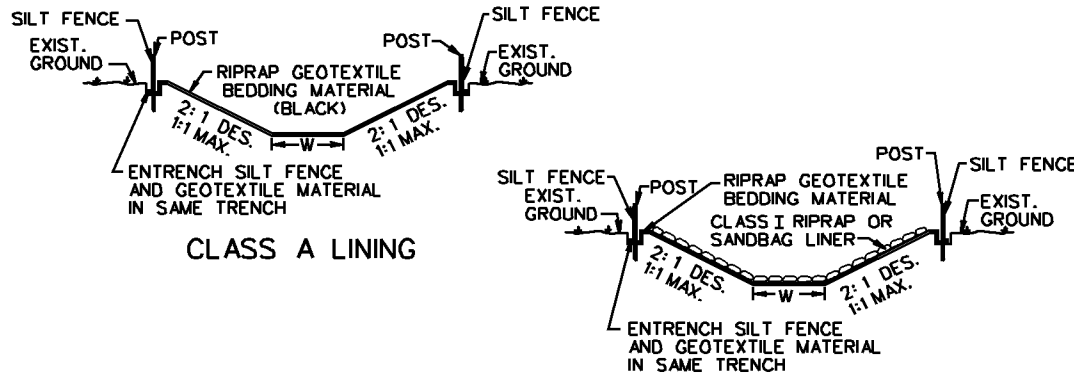

CLASS A LINING

CLASS B LINING

BOTTOM WIDTH OF TEMPORARY DIVERSION CHANNEL SHALL APPROXIMATE THE BOTTOM WIDTH OF THE NATURAL STREAM CHANNEL.

STREAM DIVERSION
GENERAL NOTES

SLOPES

MAXIMUM STEEPNESS OF SIDE SLOPES SHALL BE 1:1. DEPTH AND GRADE MAY BE VARIABLE, DEPENDENT ON SITE CONDITIONS, BUT SHALL BE SUFFICIENT TO ENSURE CONTINUOUS FLOW OF WATER IN THE DIVERSION.

EXCAVATION

NO EXCAVATED MATERIAL SHALL BE STORED OR STOCKPILED NEXT TO THE DIVERSION OR IN SUCH A MANNER THAT SILTATION OF THE STREAM COULD OCCUR.

PIPE CULVERTS

PIPE CULVERT(S) MAY BE USED TO DIVERT A STREAM PROVIDED THEY ARE PROPERLY SIZED TO SAFELY CARRY THE FLOW OF A TWO YEAR STORM EVENT. UNDERSIZED PIPES SHALL BE USED FOR NO LONGER THAN 72 HOURS PROVIDED LESS THAN 50% THREAT OF RAIN CAN BE REASONABLY EXPECTED WITHIN THAT TIME PERIOD AND THEY ARE APPROVED BY THE ENGINEER.

WHEN THE CONTRACTOR USES PIPE CULVERTS IN LIEU OF THE DIVERSION CHANNEL OR A PORTION OF THE CHANNEL, PAYMENT WILL BE MADE BASED ON THE PRICE BID FOR THE QUANTITIES SHOWN ON THE PLANS FOR TEMPORARY DIVERSION CHANNEL EXCAVATION AND TEMPORARY DIVERSION CHANNEL LINING CLASS SPECIFIED.

LINING

THE CONTRACTOR SHALL HAVE THE OPTION OF USING A HIGHER CLASS OF LINING THAN THAT SPECIFIED ON THE PLANS. NO ADDITIONAL COMPENSATION WILL BE ALLOWED FOR USING THE HIGHER CLASS.

STREAM DIVERSION LINERS SHALL BE SECURED AT THE UPSTREAM AND DOWNSTREAM SIDES WITH NON-ERODIBLE WEIGHTS SUCH AS EROSION CONTROL STONE. THESE WEIGHTS SHALL ALLOW NORMAL FLOW OF THE STREAM. SOIL SHALL NOT BE MIXED IN WITH STREAM DIVERSION WEIGHTS. WEIGHTS MAY ALSO BE NEEDED ALONG THE STREAM DIVERSION'S LENGTH.

STREAM DIVERSION LINERS SHALL BE ENTRENCHED AT THE TOP OF THE DIVERSION SLOPES (SLOPE BREAKS) WITH A LINE OF SILT FENCE.

PROTECTIVE COVERING (EC-2) STAPLES OR NON-ERODIBLE WEIGHTS SHALL BE USED AS NECESSARY TO ANCHOR STREAM DIVERSION LINERS TO THE SIDE SLOPES OF THE DIVERSION. WOODEN STAKES SHALL NOT BE USED ON THE DIVERSION'S BOTTOM OR SIDE SLOPES.

STREAM DIVERSION LINERS SHALL BE OVERLAPPED WHEN A SINGLE OR CONTINUOUS LINER IS NOT AVAILABLE OR IS IMPRACTICAL. OVERLAPS SHALL BE PLACED SUCH THAT CONTINUOUS FLOW OF THE STREAM IS MAINTAINED. AN UPSTREAM SECTION SHALL OVERLAP A DOWNSTREAM SECTION BY A MINIMUM OF 18". OVERLAPS ALONG THE CROSS SECTION SHALL BE MADE SUCH THAT A LINER IS PLACED IN THE STREAM DIVERSION BOTTOM FIRST AND ADDITIONAL PIECES OF LINER ON THE SLOPES OVERLAP THE BOTTOM PIECE BY A MINIMUM OF 18".

GENERAL

THE DOWNSTREAM PLUG SHALL BE REMOVED PRIOR TO THE UPSTREAM PLUG WHEN A STREAM DIVERSION IS USED FOR THE TRANSPORT OF WATER.

NON-ERODIBLE MATERIALS, INCLUDING BUT NOT LIMITED TO, EROSION CONTROL STONE, CONCRETE BARRIERS, SANDBAGS, PLYWOOD, OR SHEET PILING SHALL BE USED BOTH TO DIVERT THE STREAMS AWAY FROM THEIR ORIGINAL CHANNELS AND TO PREVENT OR REDUCE WATER BACKUP INTO A CONSTRUCTION AREA.

STREAMS MAY BE DIVERTED THROUGH AN EXISTING OR INCOMPLETE STRUCTURE PROVIDED THEY WILL NOT RE-ENTER A DISTURBED AREA, COME INTO CONTACT WITH WET CONCRETE, AND/OR BECOME PARTIALLY OR WHOLLY IMPOUNDED, SILTED, OR OTHERWISE CONTAMINATED.

STREAMS MAY BE REDIVERTED UPON COMPLETION OF THE DRAINAGE STRUCTURE(S) FOR WHICH THE DIVERSION WAS BUILT. PRIOR TO REDIVERSION, ANY MATERIALS USED TO PREVENT WATER BACKUP INTO THE DOWNSTREAM END OF THE DRAINAGE STRUCTURE(S) SHALL BE REMOVED. THIS MATERIAL SHALL NOT BE PLACED IN THE DOWNSTREAM END OF THE DIVERSION UNTIL AFTER WATER HAS BEEN REDIVERTED TO THE DRAINAGE STRUCTURE(S). A STREAM SHALL BE REDIVERTED BY REMOVING ALL OF THE MATERIALS DAMMING THE UPSTREAM END OF THE DRAINAGE STRUCTURE(S) BEFORE PLACING IT IN THE UPSTREAM END OF THE STREAM DIVERSION. THE DIVERSION SHALL BE SEALED OFF AT THE DOWNSTREAM END AND THEN BACKFILLED.

ONCE STARTED, ANY WORK TO RELOCATE A STREAM (PLUGS) SHALL NOT BE DISCONTINUED UNTIL IT IS COMPLETED.

ANY DEVIATIONS TO THE ABOVE NOTED STREAM DIVERSION DESIGN, INSTALLATION, OR MAINTAINANCE SHALL BE APPROVED BY THE ENGINEER.



ROAD AND BRIDGE STANDARDS

SHEET 1 OF 1

REVISION DATE

113.16

4/09

TEMPORARY DIVERSION CHANNEL

VIRGINIA DEPARTMENT OF TRANSPORTATION

SPECIFICATION
REFERENCE

302

303

414

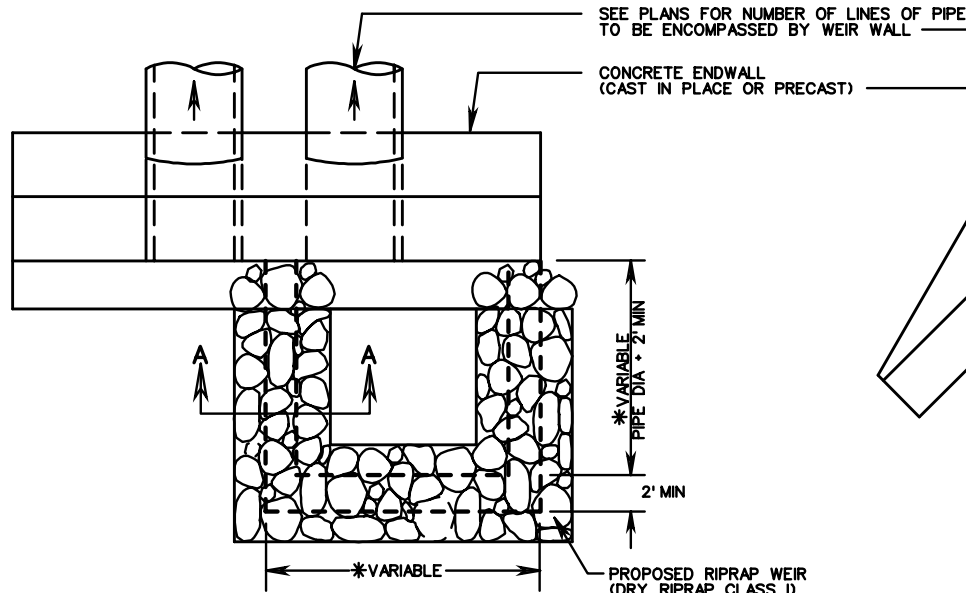

PLAN VIEW
(ENDWALL WITHOUT WINGS)

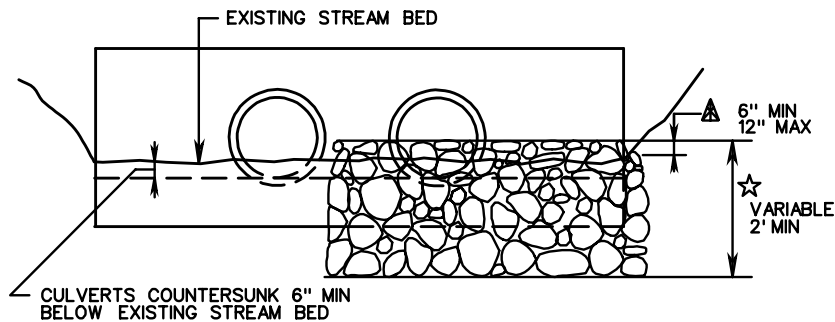

END VIEW

LEGEND

- Ⓐ 6' MINIMUM OR 1/2 P.
- * DIMENSION VARIES ACCORDING TO PIPE SIZE, SKEW AND ENDWALL DIMENSIONS
- ☆ DEPTH OF FOUNDATION TO BE VARIABLE ACCORDING TO SITE CONSTRAINTS OR AS DIRECTED BY THE ENGINEER
- ▲ THE PROPOSED HEIGHT OF THE RIPRAP WEIR, FROM THE EXISTING STREAM BED TO THE TOP OF WEIR, IS TO BE SPECIFIED ON THE ROADWAY PLANS. "X" DIMENSION (HEIGHT OF WEIR ABOVE STREAM BED) CAN BE A MINIMUM OF 6" OR ANY VARIABLE DIMENSION TO A MAXIMUM OF 12".

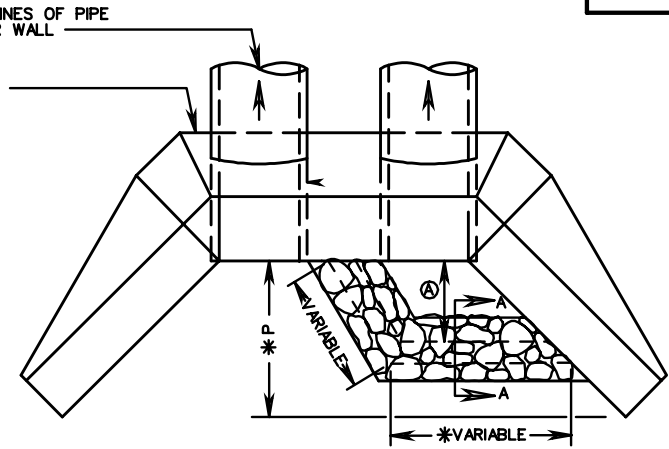

PLAN VIEW
(ENDWALL WITH WINGS)

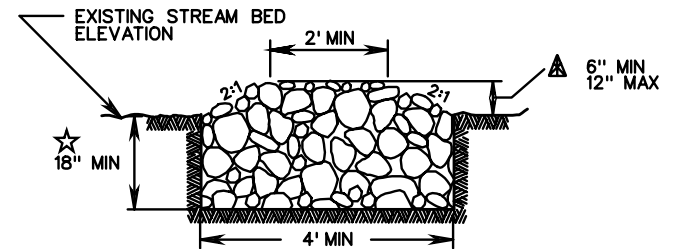

TYPICAL SECTION A-A

NOTES:

1. THE TOP WIDTH OF THE WEIR IS VARIABLE AND IS TO BE ADJUSTED AS NEEDED TO DIRECT THE LOW FLOW TO THE BARREL(S) DESIGNATED ON THE PLANS.
2. FOR SKEWED ENDWALLS, RIPRAP WEIR SIDES ARE TO BE CONSTRUCTED PARALLEL WITH PIPE SKEW.
3. REFER TO APPLICABLE ENDWALL STANDARD DRAWING FOR DIMENSIONS NOT SHOWN HEREIN
4. BASIS OF PAYMENT: TO BE PAID FOR AS SQ.YDS. OR TONS OF DRY RIPRAP CLASS I

SPECIFICATION
REFERENCE

107
303

RIPRAP WEIRS
LOW FLOW DIVERSION FOR MULTIPLE LINE CULVERT INSTALLATIONS

VIRGINIA DEPARTMENT OF TRANSPORTATION

VDOT

ROAD AND BRIDGE STANDARDS

REVISION DATE

SHEET 1 OF 1

113.17

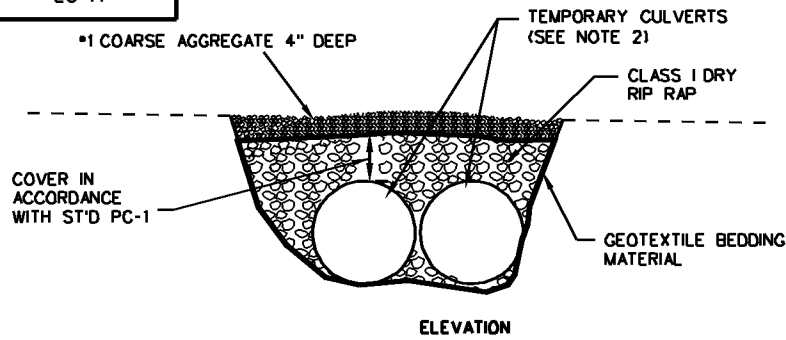

ELEVATION

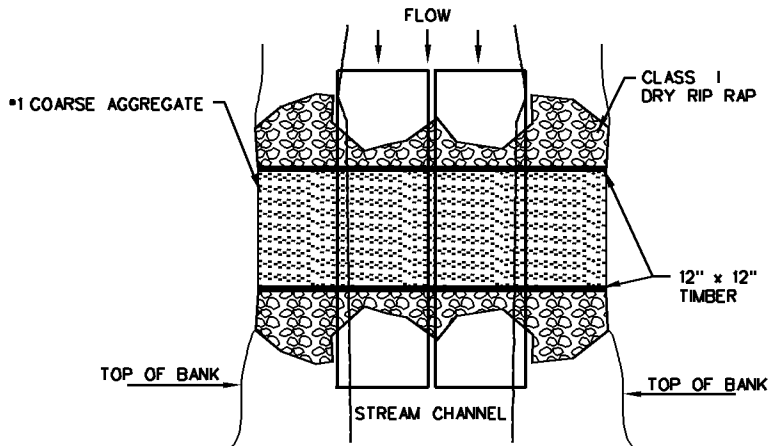

PLAN VIEW

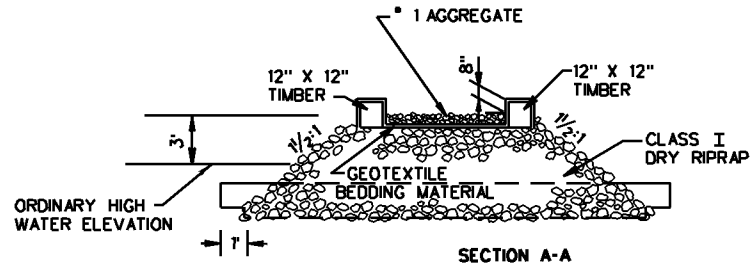
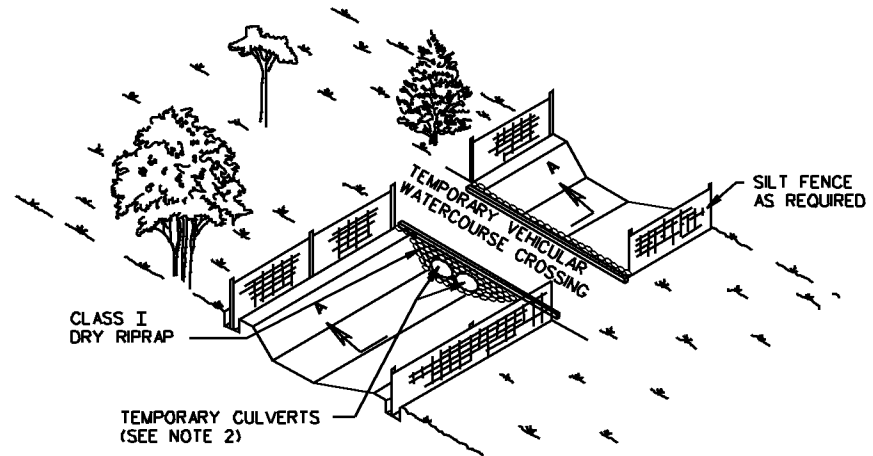

NOTE:

1. THE CULVERT(S) SHALL BE SIZED TO CONVEY THE FLOW OF A TWO YEAR STORM EVENT. THE ELEVATION OF THE TWO YEAR EVENT SHALL BE AT OR BELOW THE LOWEST SURFACE ELEVATION OF THE CROSSING. THE REQUIRED HYDRAULIC OPENINGS SHOULD BE DETERMINED USING THE APPROPRIATE HYDROLOGIC/HYDRAULIC DESIGN TECHNIQUES. A TEMPORARY VEHICULAR WATERCOURSE CROSSING SHOULD ONLY BE UTILIZED WHERE THE DRAINAGE AREA IS NO GREATER THAN 1 SQUARE MILE. THE DEPTH OF STONE COVER OVER THE CULVERT(S) SHALL BE IN ACCORDANCE WITH STANDARD PC-1.

2. AN ALTERNATIVE TEMPORARY VEHICULAR WATERCOURSE CROSSING DESIGN MAY BE USED PROVIDED IT IS SUBMITTED TO THE ENGINEER FOR REVIEW AND APPROVAL IN ACCORDANCE WITH ROAD AND BRIDGE SPECIFICATIONS 105.10 AND 107.02.



ROAD AND BRIDGE STANDARDS

TEMPORARY VEHICULAR WATERCOURSE CROSSING

SPECIFICATION REFERENCE

SHEET 1 OF 1

REVISION DATE

113.18

4/09

VIRGINIA DEPARTMENT OF TRANSPORTATION

302
303
414

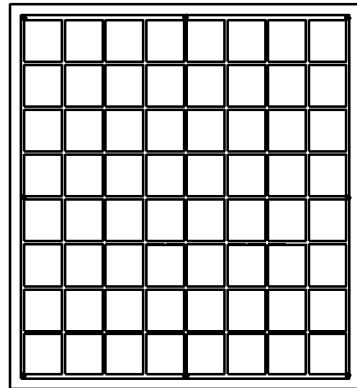

PLAN VIEW

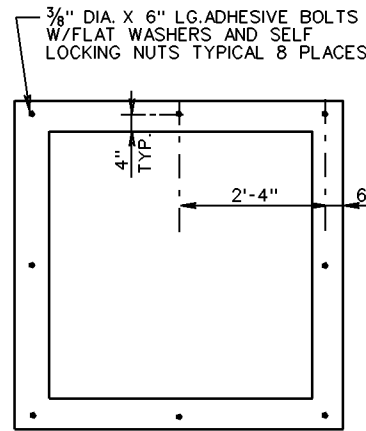

PLAN VIEW
(TRASH RACK NOT SHOWN)

NOTES:

1. COST OF TRASH RACK AND DEBRIS RACK ARE TO BE INCLUDED IN THE BID PRICE FOR THE STORMWATER MANAGEMENT DRAINAGE STRUCTURE.
2. STRUCTURE MAY BE PRECAST OR CAST IN PLACE. SEE SHEET 2 OF 3 FOR DETAILS ON PRECAST STRUCTURE.
3. WEEP HOLES SHALL NOT BE PROVIDED.
4. STEPS ARE TO BE PROVIDED WHEN HEIGHT OF STRUCTURE IS 4'-0" OR GREATER ABOVE INVERT OF OUTLET PIPE. FOR STEP DETAILS SEE STANDARD ST-1.
5. FOR DETAILS ON METAL PLATE, DEBRIS RACK AND TRASH RACK SEE STANDARD SWM-DR.
6. MARK HEIGHT OF STRUCTURE, IN BLACK, WITH 4" HIGH NUMERALS AND 1" WIDE HORIZONTAL STRIPES AT 1' INTERVALS FROM INVERT OF WATER QUALITY ORIFICE (ALL VISIBLE SIDES).
7. THE PERMANENT STORMWATER MANAGEMENT DRAINAGE STRUCTURE, STANDARD SWM-1 MAY BE MODIFIED WHERE THE STORMWATER MANAGEMENT BASIN IS TO BE USED AS A TEMPORARY SEDIMENT BASIN DURING PROJECT CONSTRUCTION. SEE STANDARD SWM-DR, SHEET 1 OF 5, FOR TEMPORARY MODIFICATION DETAILS.
8. THE SIZE OF THE WATER QUALITY ORIFICE SHALL BE SPECIFIED ON THE PLANS. ADDITIONAL OPENINGS IN THE STORMWATER MANAGEMENT DRAINAGE STRUCTURE TO BE PROVIDED WHEN SPECIFIED ON THE PLANS.

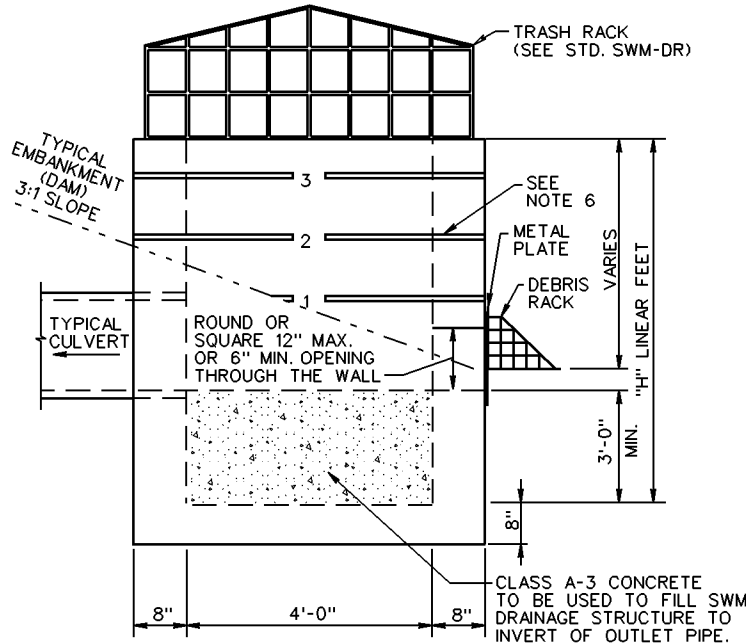

SIDE VIEW
SWM DRAINAGE STRUCTURE

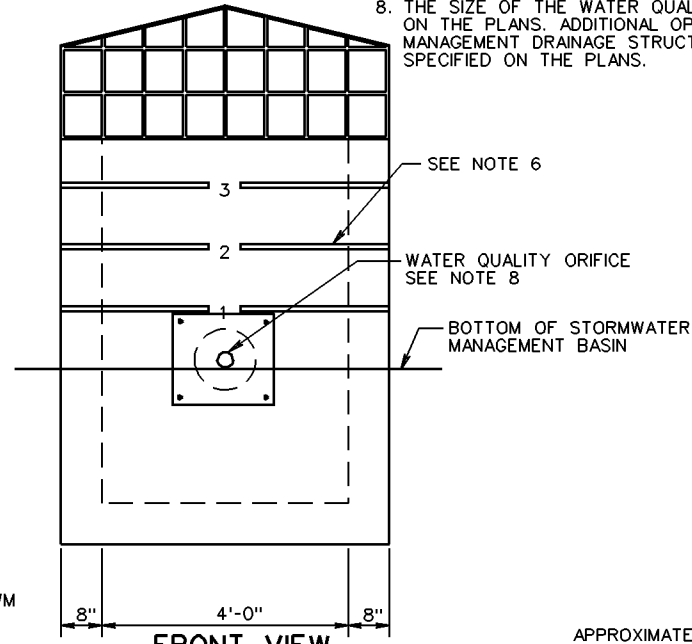

FRONT VIEW
(DEBRIS RACK NOT SHOWN)

APPROXIMATE QUANTITIES
CAST-IN-PLACE CLASS A-3 CONCRETE TO BE USED.
MAXIMUM DEPTH (H) TO BE 12'-8".

PIPE SIZE	12"	15"	18"	24"	30"	36"	42"
MINIMUM DEPTH H	5'-0"	5'-3/4"	5'-6 1/2"	6'-1"	6'-7 1/2"	7'-2"	7'-8 1/2"
CU. YDS. CONCRETE	2.665	2.773	2.878	3.078	3.624	3.437	3.598

INCREMENT PER FOOT OF ADDITIONAL DEPTH "H" = 0.461 CU. YDS.

SPECIFICATION REFERENCE

302

CAST IN PLACE STORMWATER MANAGEMENT DRAINAGE STRUCTURE

VIRGINIA DEPARTMENT OF TRANSPORTATION

VDOT

ROAD AND BRIDGE STANDARDS

REVISION DATE

08/10

SHEET 1 OF 3

114.01

NOTES:

1. COST OF TRASH RACK AND DEBRIS RACK ARE TO BE INCLUDED IN THE PRICE BID FOR THE STORMWATER MANAGEMENT DRAINAGE STRUCTURE.
2. STRUCTURE MAY BE PRECAST OR CAST IN PLACE. SEE SHEET 1 OF 3 FOR DETAILS ON CAST IN PLACE STRUCTURE.
3. WEEP HOLES SHALL NOT BE PROVIDED. ANY LIFT HOLES SHALL BE PLUGGED.
4. STEPS ARE TO BE PROVIDED WHEN HEIGHT OF STRUCTURE IS 4'-0" OR GREATER ABOVE INVERT OF OUTLET PIPE. FOR STEP DETAILS SEE STANDARD ST-1.
5. SEE STANDARD SWM-DR FOR DETAILS ON PLATE, DEBRIS RACK AND TRASH RACK.
6. MARK HEIGHT OF STRUCTURE, IN BLACK, WITH 4" HIGH NUMERALS AND 1" WIDE HORIZONTAL STRIPES AT 1' INTERVALS FROM INVERT OF WATER QUALITY ORIFICE (ALL VISIBLE SIDES).
7. THE PERMANENT STORMWATER MANAGEMENT DRAINAGE STRUCTURE, STANDARD SWM-1 MAY BE MODIFIED WHERE THE STORMWATER MANAGEMENT BASIN IS TO BE USED AS A TEMPORARY SEDIMENT BASIN DURING PROJECT CONSTRUCTION. SEE STANDARD SWM-DR, SHEET 1 OF 5 FOR TEMPORARY MODIFICATION DETAILS.
8. THE SIZE OF THE WATER QUALITY ORIFICE SHALL BE SPECIFIED ON THE PLANS. ADDITIONAL OPENINGS IN THE STORMWATER MANAGEMENT STRUCTURE TO BE PROVIDED WHEN SPECIFIED ON THE PLANS.

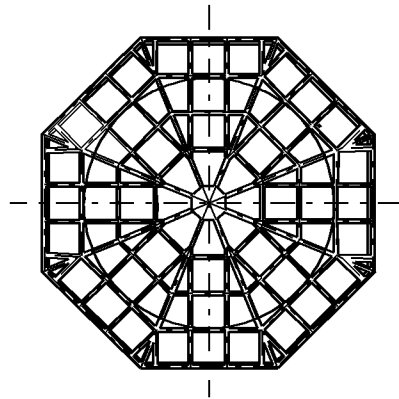

PLAN VIEW

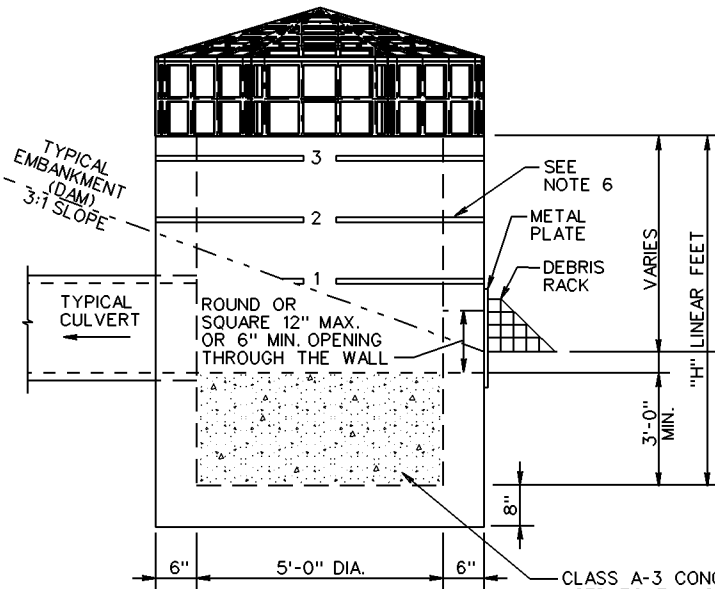

SIDE VIEW
SWM DRAINAGE STRUCTURE

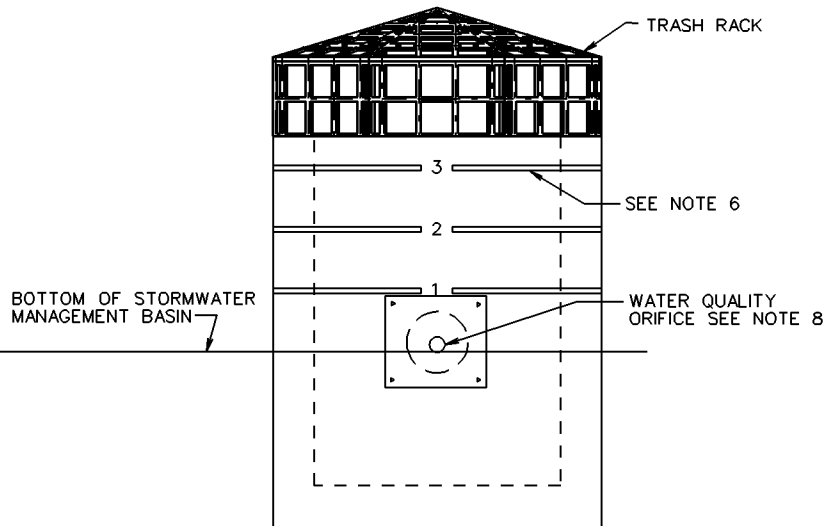

FRONT VIEW
(DEBRIS RACK NOT SHOWN)

CLASS A-3 CONCRETE TO BE USED TO FILL SWM DRAINAGE STRUCTURE TO INVERT OF OUTLET PIPE.



ROAD AND BRIDGE STANDARDS

PRECAST STORMWATER MANAGEMENT DRAINAGE STRUCTURE

SPECIFICATION REFERENCE

SHEET 2 OF 3

REVISION DATE

105
302

114.02

08/10

VIRGINIA DEPARTMENT OF TRANSPORTATION

THIS PAGE INTENTIONALLY LEFT BLANK

SPECIFICATION
REFERENCE

VIRGINIA DEPARTMENT OF TRANSPORTATION



ROAD AND BRIDGE STANDARDS

REVISION DATE

SHEET 1 OF 1

114.03

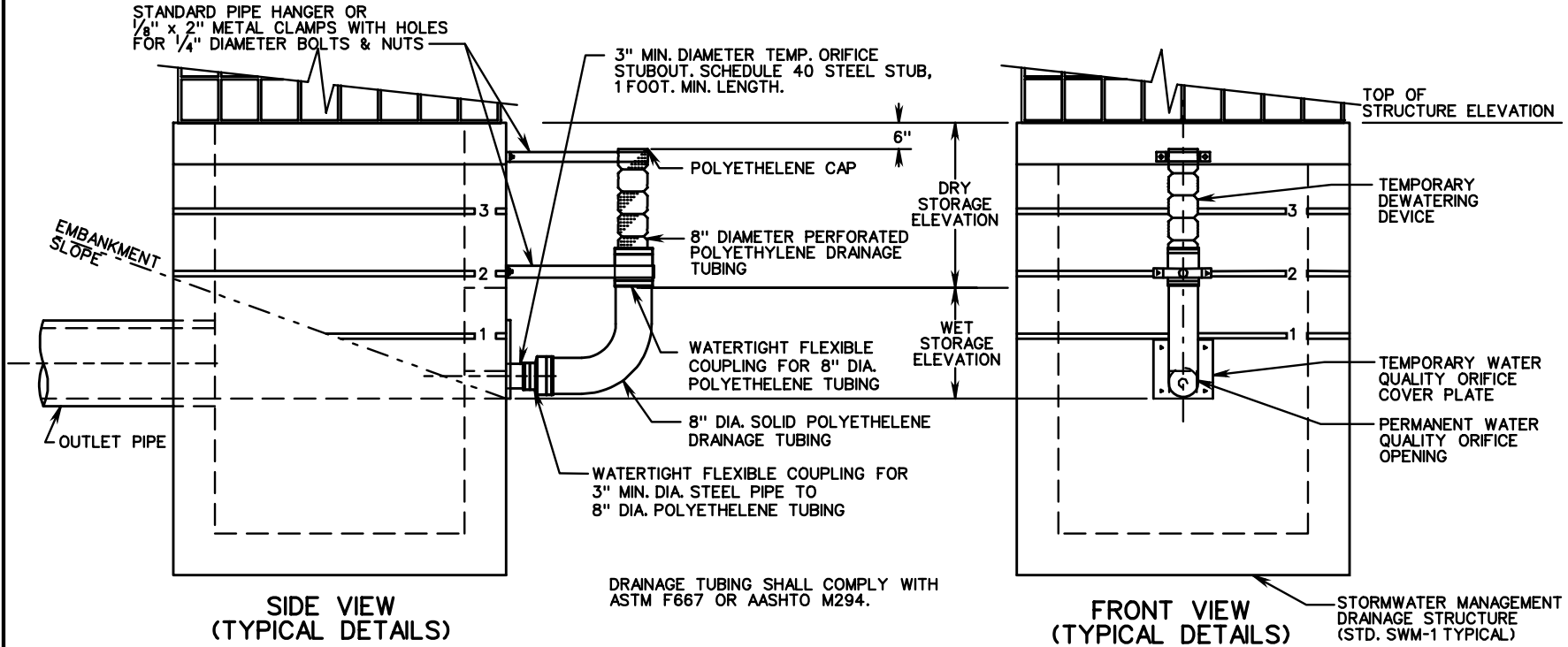

DRAINAGE TUBING SHALL COMPLY WITH ASTM F667 OR AASHTO M294.

NOTES:

1. THESE DETAILS ARE TO BE USED TO MODIFY THE PERMANENT STORMWATER MANAGEMENT DRAINAGE STRUCTURE WHERE THE STORMWATER MANAGEMENT BASIN IS TO BE USED FOR A TEMPORARY SEDIMENT BASIN DURING PROJECT CONSTRUCTION.
2. GRADE STORMWATER MANAGEMENT BASIN AS SHOWN IN PLANS.
3. ALL OPENINGS (IF ANY) IN SIDE OF STRUCTURE (OTHER THAN PERMANENT WATER QUALITY ORIFICE) ARE TO BE COVERED WITH SOLID METAL PLATES WHILE THE BASIN IS BEING USED FOR SEDIMENT CONTROL.
4. DEWATERING DEVICE AND COMPONENTS AND TEMPORARY METAL PLATES (IF ANY), AS SHOWN IN THE DETAIL, ARE TO BE REMOVED AND PERMANENT STEEL PLATE WITH WATER QUALITY ORIFICE IS TO BE INSTALLED WHEN BASIN IS NO LONGER NEEDED FOR SEDIMENT CONTROL.
5. SIMILAR DEVICE MAY ALSO BE USED ON OTHER STORMWATER MANAGEMENT DRAINAGE STRUCTURES.
6. COST OF TEMPORARY DEWATERING DEVICE AND TEMPORARY METAL PLATES (IF ANY) SHALL BE INCLUDED IN THE BID PRICE FOR STORMWATER MANAGEMENT DRAINAGE STRUCTURE.
7. THE TEMPORARY 8" DIA. POLYETHELENE DRAINAGE TUBING IS TO BE SOLID FOR THE LENGTH BELOW WET STORAGE ELEVATION AND IS TO BE PERFORATED ABOVE THE WET STORAGE ELEVATION. THE COUPLING IS TO BE WATERTIGHT.



ROAD AND BRIDGE STANDARDS

SHEET 1 OF 5

REVISION DATE

114.04

STORMWATER MANAGEMENT (SWM) DETAILS

VIRGINIA DEPARTMENT OF TRANSPORTATION

SPECIFICATION REFERENCE

302

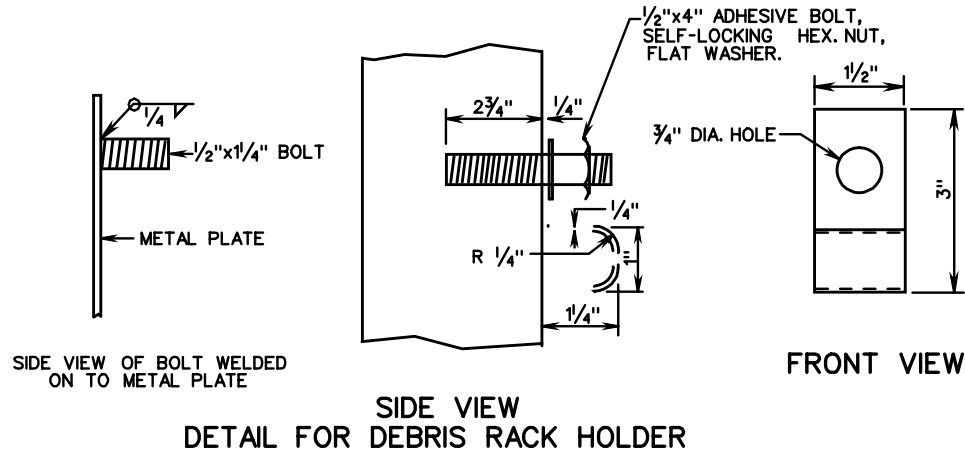

1. COST OF DEBRIS RACK, METAL PLATE, AND DEBRIS RACK HOLDER TO BE INCLUDED IN THE BID PRICE FOR THE SWM DRAINAGE STRUCTURE.
2. DEBRIS RACK MAY BE FABRICATED FROM WELDED 3/8" DIAMETER BARS OR 1/2" THICK HIGH DENSITY POLYETHYLENE. METAL COMPONENTS OF DEBRIS RACK MUST NOT BE GALVANIZED.
3. DEBRIS RACK TO BE HINGED AS SHOWN OR CONTRACTOR MAY SUBSTITUTE A COMPARABLE DESIGN AS APPROVED BY THE ENGINEER.
4. THE LOCATION OF THE DEBRIS RACK HOLDER MAY BE ADJUSTED FOR VARIABLE CONDITIONS. WHEN HOLDER BOLT IS LOCATED ON THE METAL PLATE THE 1/2" DIA. BOLT LENGTH IS TO BE REDUCED 1/4" LG. AND WELDED TO THE PLATE. DEBRIS RACK HOLDER AND ALL HARDWARE IS TO BE GALVANIZED.

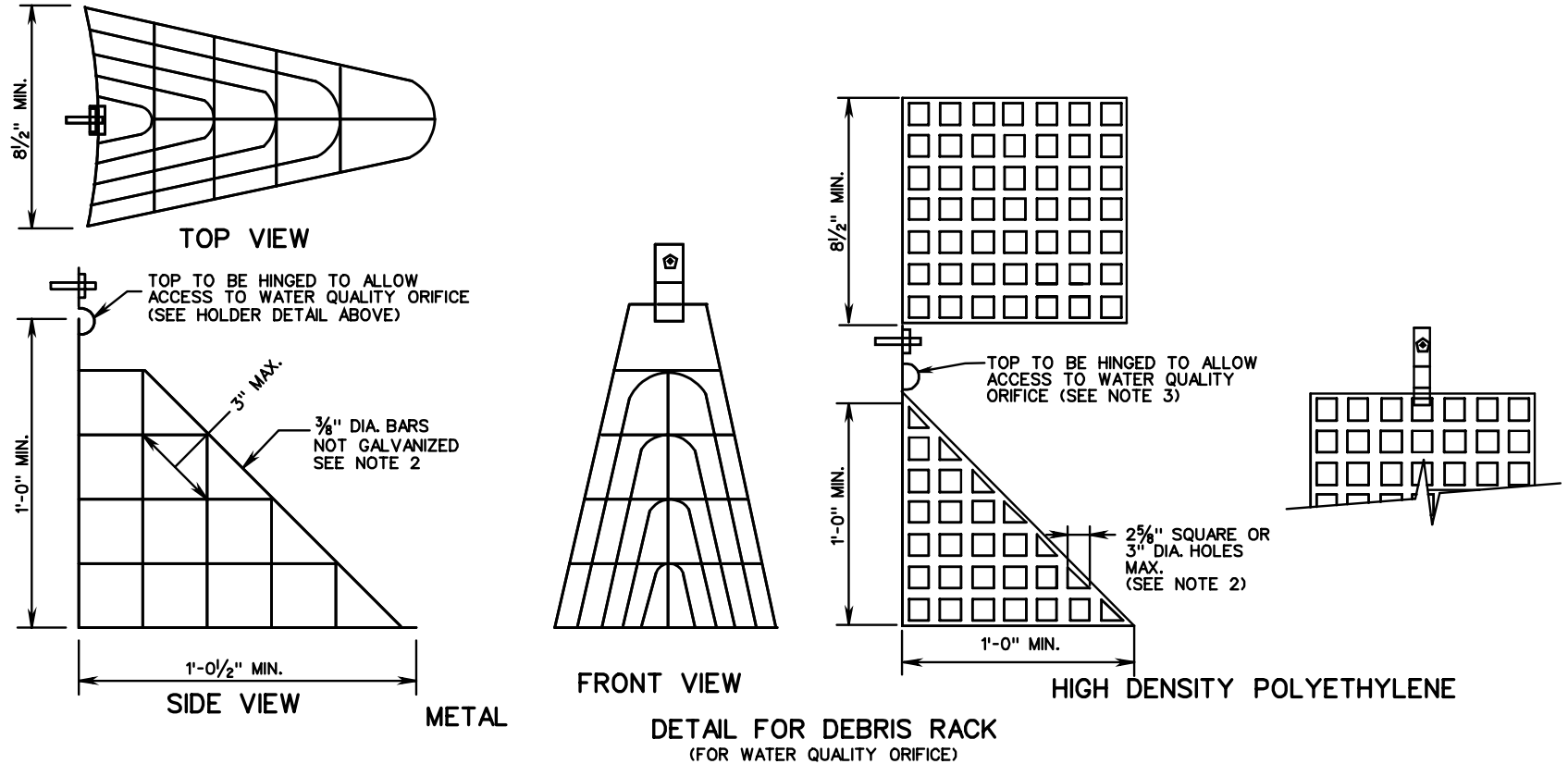

SPECIFICATION REFERENCE

302

STORMWATER MANAGEMENT (SWM) DETAILS
DEBRIS RACK, METAL PLATE, WATER QUALITY ORIFICE, CONCRETE CRADLE
(FOR SWM DRAINAGE STRUCTURES, SWM RISER PIPES AND SWM DAMS)
 VIRGINIA DEPARTMENT OF TRANSPORTATION

VDOT

ROAD AND BRIDGE STANDARDS

REVISION DATE

SHEET 2 OF 5

114.05

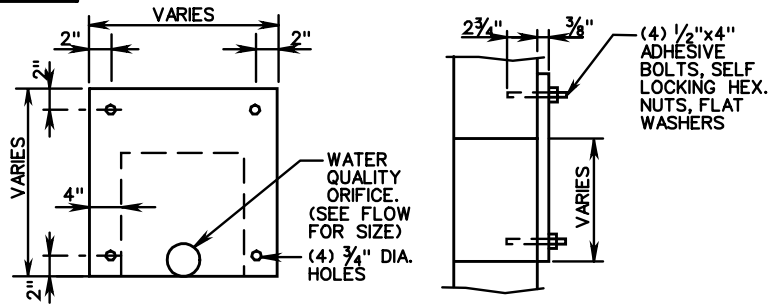

SWM DAM METAL PLATE DETAIL
(NOT GALVANIZED)

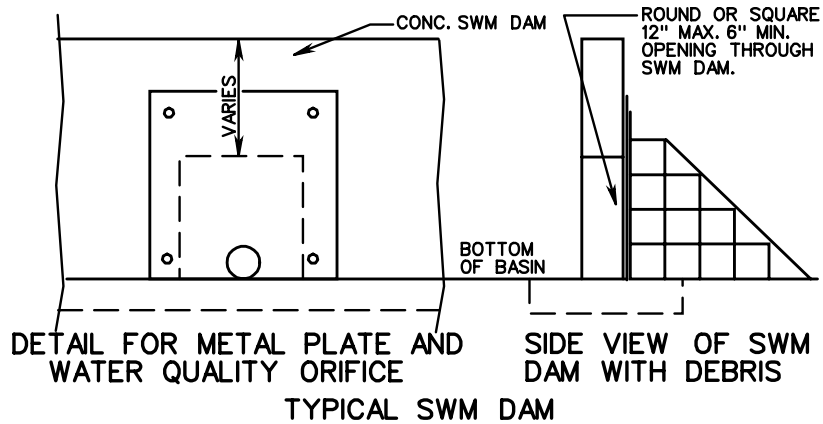

TYPICAL SWM DAM

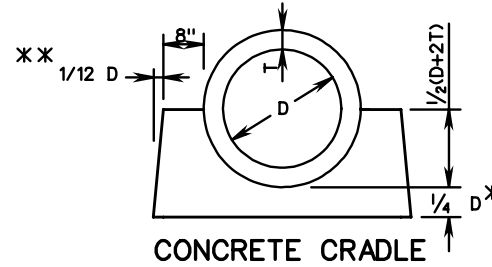

PIPE SIZE INCHES	CRADLE BOTTOM WIDTH (INCHES)	CRADLE HEIGHT (INCHES)	CRADLE TOP WIDTH (INCHES)	INCREMENT, IN CUBIC YARDS, PER LINEAR FOOT OF PIPE
12	34	14	32	0.093
15	38	15.75	35.5	0.110
18	42	17.5	39	0.129
24	50	21	46	0.168
30	58	26	53	0.233
36	66	31	60	0.307
42	74	36	67	0.390

CONCRETE SHALL BE CLASS A3 BUT NOT LESS THAN 6"

* * IF THE PIPE IS LAID IN AN EXCAVATED TRENCH, THEN THE SIDE WALLS MAY CONFORM TO THE TRENCH SHAPE (IE THE TRENCH MAY BECOME THE CRADLE FORM).

CONCRETE CRADLE IS TO BE INSTALLED UNDER THE ENTIRE LENGTH OF CULVERT AT EACH STORMWATER MANAGEMENT BASIN.

CONCRETE CRADLE IS TO BE PAID FOR AS MISCELLANEOUS CONCRETE AND SUMMARIZED IN CUBIC YARDS FOR EACH PIPE LOCATION

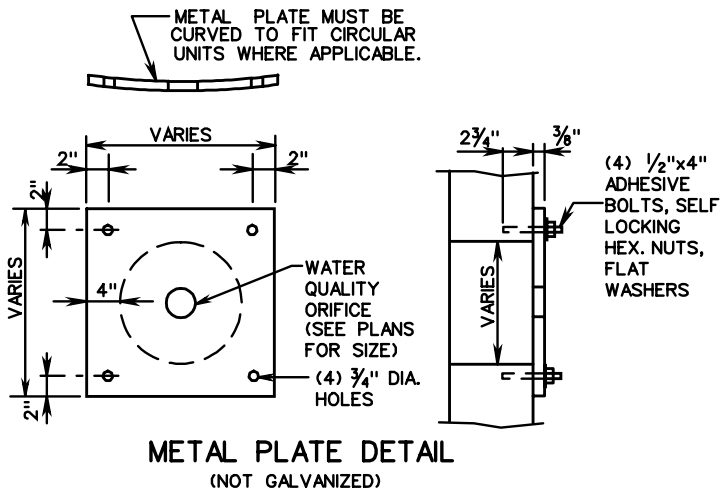

METAL PLATE DETAIL
(NOT GALVANIZED)

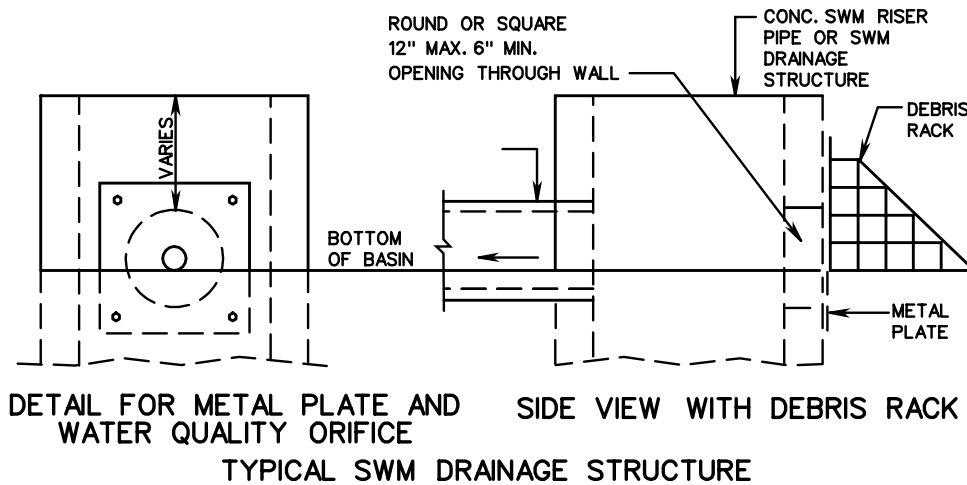

DETAIL FOR METAL PLATE AND WATER QUALITY ORIFICE
TYPICAL SWM DRAINAGE STRUCTURE

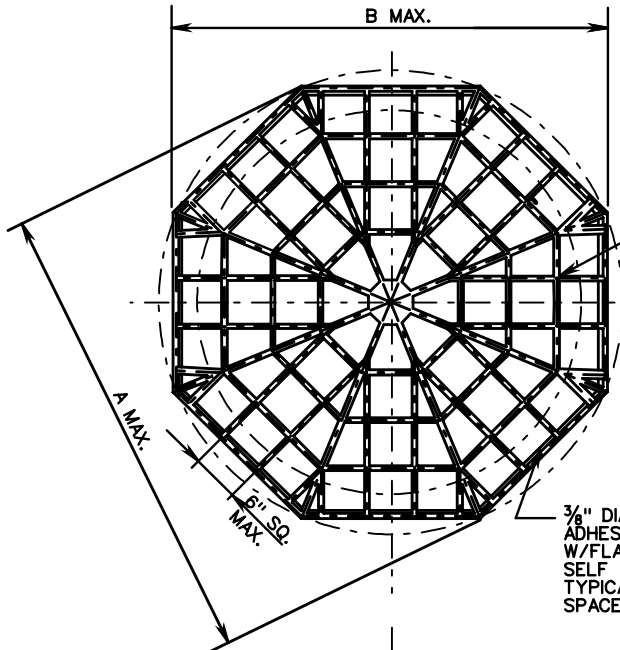

3/8" DIA. X 6" LG. ADHESIVE BOLTS W/FLAT WASHERS AND SELF LOCKING NUTS TYPICAL 8 PLACES-EQUALLY SPACED ON AN "E" DIA. B.C.

LOCKABLE ACCESS DOOR W/HINGE, MIN. 2' x 2' CLEAR OPENING SEE NOTE 1

3/8" DIA. X 6" LG. ADHESIVE BOLTS W/FLAT WASHERS AND SELF LOCKING NUTS. TYPICAL 8 PLACES-EQUALLY SPACED ON AN "E" DIA. B.C.

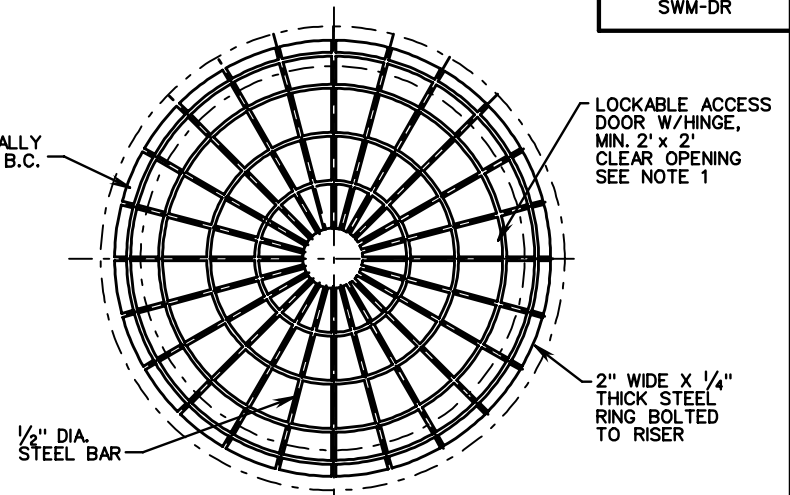

LOCKABLE ACCESS DOOR W/HINGE, MIN. 2' x 2' CLEAR OPENING SEE NOTE 1

2" WIDE X 1/4" THICK STEEL RING BOLTED TO RISER

1/2" DIA. STEEL BAR

1/2" THICK STEEL PLATE

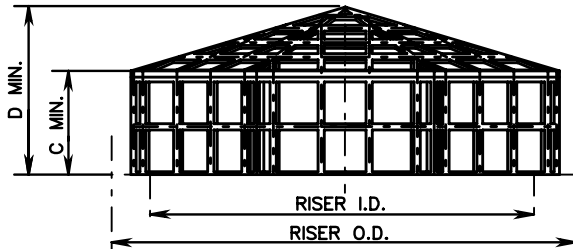

CIRCULAR STORMWATER MANAGEMENT DRAINAGE STRUCTURE

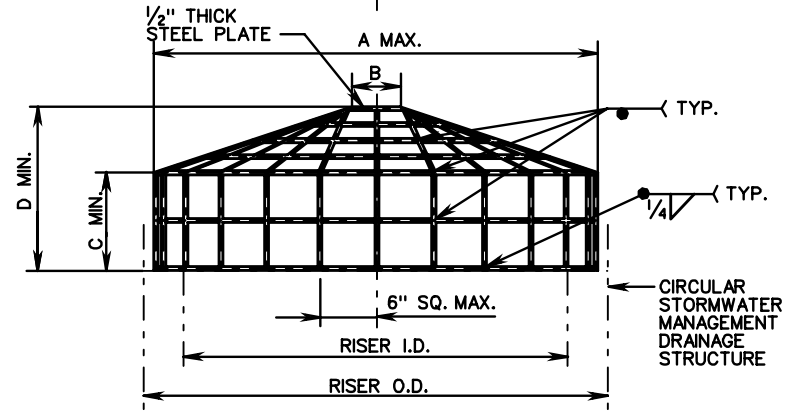

CIRCULAR STORMWATER MANAGEMENT DRAINAGE STRUCTURE

RISER		DIMENSION					APPROX. WT. (LBS.)
I.D.	O.D.	A	B	C	D	E	
24	30	31	28 ⁵ / ₈	7	11	27	24
36	44	45	41 ¹ / ₂	13	19	40	58
48	58	59	54 ¹ / ₂	13	21	53	86
60	72	73	67 ¹ / ₂	17	28	66	135
72	86	87	80 ³ / ₈	23	35	79	204
84	100	101	93 ³ / ₄	25	39	92	266
96	114	115	106 ¹ / ₄	22	38	105	305

HIGH DENSITY POLYETHYLENE

RISER		DIMENSION					APPROX. WT. (LBS.)	
I.D.	O.D.	A	B	C	D	E	SEGMENT	
24	30	30	6	7	10	27	15	46
36	44	42	6	13	18	40	22	82
48	58	55	9	13	20	53	29	120
60	72	68	9	17	26	66	36	169
72	86	81	9	23	34	79	42	227
84	100	94	12	25	37	92	49	290
96	114	107	12	22	36	105	56	341

METAL

NOTES:

1. A HINGED, LOCKABLE ACCESS DOOR SHALL BE PROVIDED ON ALL TRASH RACKS IF THE TOTAL WEIGHT OF THE TRASH RACK IS GREATER THAN 75 LBS OR IF THE TRASH RACK IS TO BE PLACED ON A SWM-1 WITH AN "H" DIMENSION GREATER THAN 7'-2".

2. ANTI-VORTEX PLATE IS TO BE USED WHEN SPECIFIED ON THE PLANS. COST OF FURNISHING AND PLACING THE ANTI-VORTEX PLATE IS TO BE INCLUDED IN THE BID PRICE FOR THE STRUCTURE.

SPECIFICATION REFERENCE

302

STORMWATER MANAGEMENT DETAILS TRASH RACK FOR SWM DRAINAGE STRUCTURES

VIRGINIA DEPARTMENT OF TRANSPORTATION

VDOT

ROAD AND BRIDGE STANDARDS

REVISION DATE

SHEET 4 OF 5

114.07

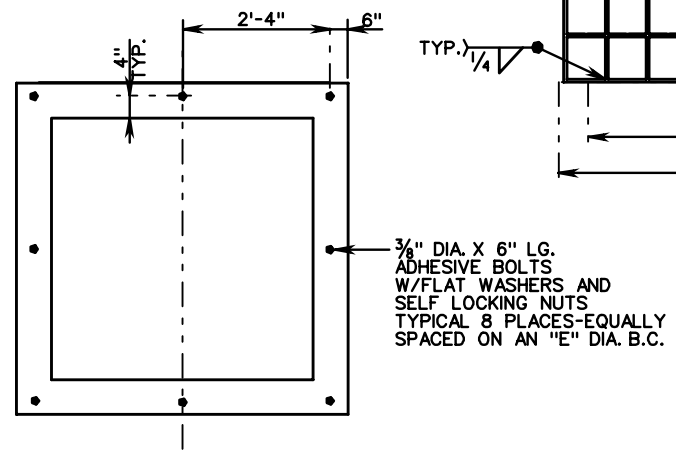
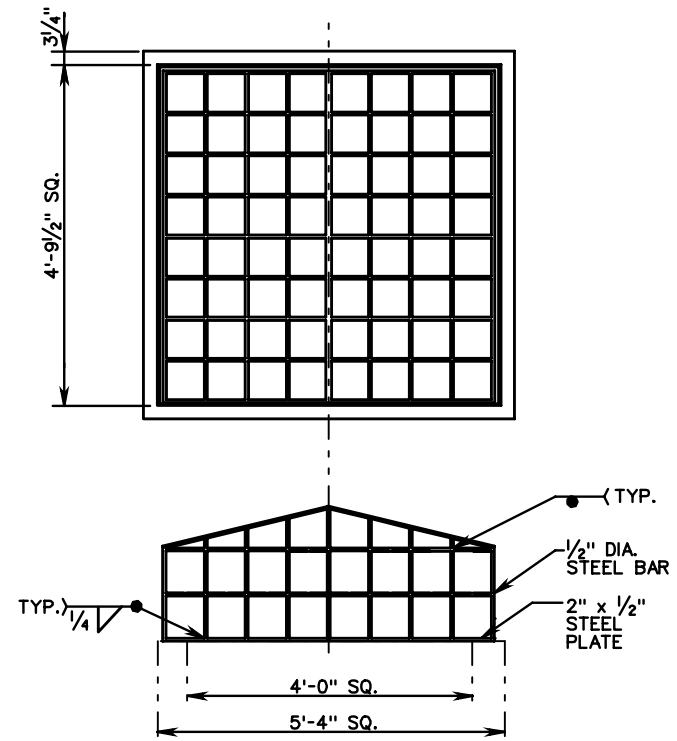
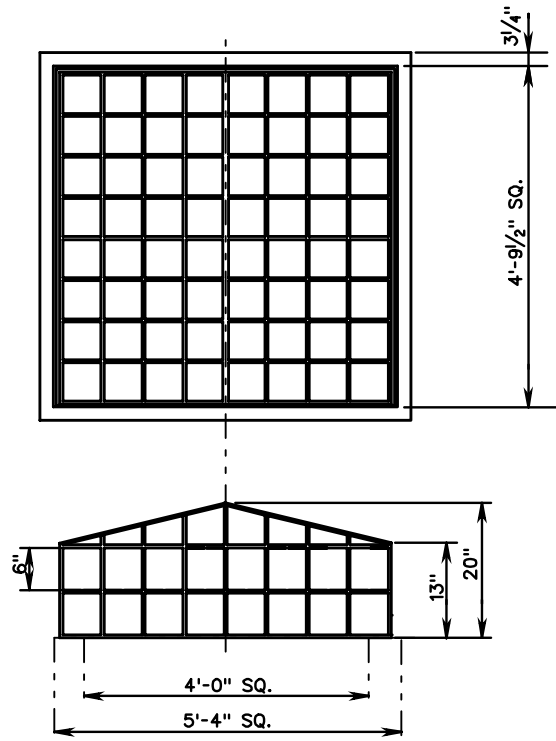

NOTE:
A HINGED, LOCKABLE ACCESS DOOR
WITH A MINIMUM 2' x 2' CLEAR OPENING,
SHALL BE PROVIDED ON ALL TRASH RACKS.

HIGH DENSITY POLYETHYLENE

METAL (STEEL)

APPROX. WT. (LBS.)
95

APPROX. WT. (LBS.)
188

SECTION 200

CURBS, MEDIANS
&
ENTRANCE GUTTERS

THIS PAGE INTENTIONALLY LEFT BLANK



ROAD AND BRIDGE STANDARDS

SHEET 1 OF 1

REVISION DATE

SPECIFICATION
REFERENCE

VIRGINIA DEPARTMENT OF TRANSPORTATION

STANDARD	TITLE	PAGE
CG-2	STANDARD 6" CURB	201.01
CG-3	STANDARD 4" CURB	201.02
CG-6	COMBINATION 6" CURB AND GUTTER	201.03
CG-7	COMBINATION 4" CURB AND GUTTER	201.04
MC-3, 3A	ASPHALT CONCRETE CURB AND MEDIAN (FOR TEMPORARY OR PERMANENT INSTALLATION)	201.05
MC-3B, 3C	ASPHALT CONCRETE CURB AND MEDIAN (FOR TEMPORARY OR PERMANENT INSTALLATION)	201.06
MC-4	ASPHALT CURB AND GUTTER (ASPHALT PAVING UNDER GUARDRAIL)	201.07
	ASPHALT CURB AND GUTTER (ASPHALT PAVING UNDER GUARDRAIL)	201.08
MC-1	CONCRETE MEDIAN CURB	202.01
MS-1	STANDARD SOLID CONCRETE RAISED MEDIAN STRIP	202.02
MS-1A	STANDARD SOLID CONCRETE RAISED MEDIAN STRIP	202.03
MS-2	STANDARD RAISED GRASS MEDIAN STRIP	202.04
MS-4	STANDARD RAISED ASPHALT MEDIAN (WITH P.C. CONCRETE CURB)	202.05
CG-9A	STANDARD ENTRANCE GUTTER WITH FLARED OPENING (FOR USE ACROSS SIDEWALK)	203.01
CG-9B	STANDARD ENTRANCE GUTTER (FOR USE WITH UNPAVED SPACE BETWEEN CURB AND GUTTER)	203.02
CG-9D	STANDARD ENTRANCE GUTTER	203.03
CG-11	METHOD OF TREATMENT (CONNECTION FOR STREET INTERSECTIONS)	203.04
CG-12	CG-12 DETECTABLE WARNING SURFACE (GENERAL NOTES)	203.05
	CG-12 DETECTABLE WARNING SURFACE (TYPE A, PERPENDICULAR APPLICATION)	203.06
	CG-12 DETECTABLE WARNING SURFACE (TYPE B, PARALLEL APPLICATION)	203.07
	CG-12 DETECTABLE WARNING SURFACE (TYPE C, PARALLEL & PERPENDICULAR APPLICATION)	203.08
	CG-12 DETECTABLE WARNING SURFACE - (MEDIAN AND REFUGE ISLAND APPLICATIONS) TYPE M1, M2, & R11, & R12	203.08A
CG-13	COMMERCIAL ENTRANCE (HEAVY TRUCK TRAFFIC ANTICIPATED)	203.09

INDEX OF SHEETS
SECTION 200-CURBS AND ENTRANCES
 VIRGINIA DEPARTMENT OF TRANSPORTATION



ROAD AND BRIDGE STANDARDS

REVISION DATE	SHEET 1 OF 1
08/14	200.01

THIS PAGE INTENTIONALLY LEFT BLANK



ROAD AND BRIDGE STANDARDS

SHEET 1 OF 1

REVISION DATE

200.02

VIRGINIA DEPARTMENT OF TRANSPORTATION

SPECIFICATION
REFERENCE

NOTES:

1. THIS ITEM MAY BE PRECAST OR CAST IN PLACE.
2. CONCRETE TO BE CLASS A3 IF CAST IN PLACE, 4000 PSI IF PRECAST.
3. CURB HAVING A RADIUS OF 300 FEET OR LESS (ALONG FACE OF CURB) WILL BE PAID FOR AS RADIAL CURB.
4. THE DEPTH OF CURB MAY BE REDUCED AS MUCH AS 3" (15" DEPTH) OR INCREASED AS MUCH AS 3" (21" DEPTH) IN ORDER THAT THE BOTTOM OF CURB WILL COINCIDE WITH THE TOP OF A COURSE OF THE PAVEMENT SUBSTRUCTURE. OTHERWISE, THE DEPTH IS TO BE 18" AS SHOWN. NO ADJUSTMENT IN THE PRICE BID IS TO BE MADE FOR A DECREASE OR AN INCREASE IN DEPTH.
5. CG-2 IS TO BE USED ON ROADWAYS MEETING THE REQUIREMENTS FOR CG-6 AS SHOWN IN APPENDIX A OF THE VDOT ROAD DESIGN MANUAL, IN THE SECTION ON GS URBAN STANDARDS.

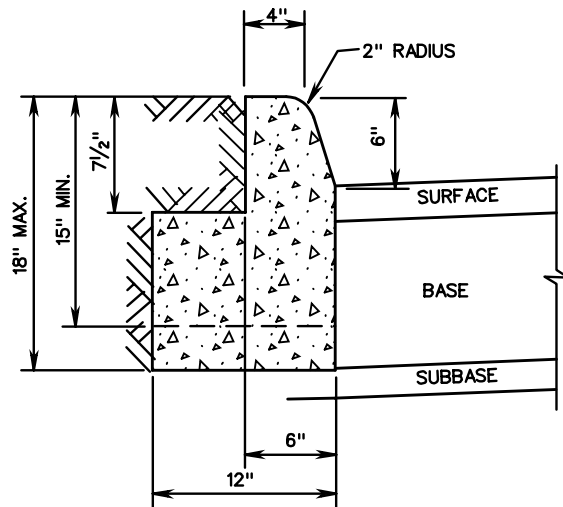
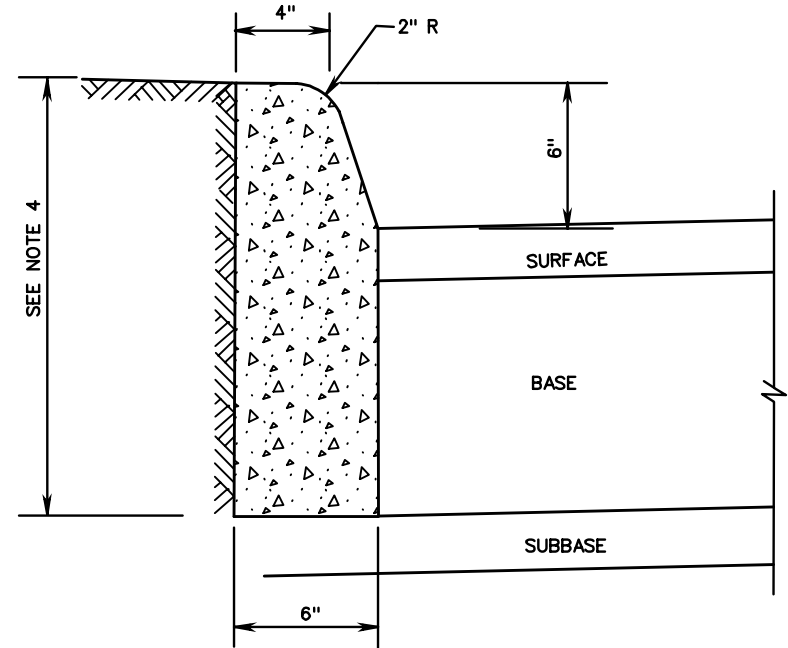

**ACCEPTABLE ALTERNATIVE
IF CURB IS EXTRUDED**

SPECIFICATION
REFERENCE

105
502

STANDARD 6" CURB

VIRGINIA DEPARTMENT OF TRANSPORTATION

VDOT

ROAD AND BRIDGE STANDARDS

REVISION DATE

SHEET 1 OF 1

201.01

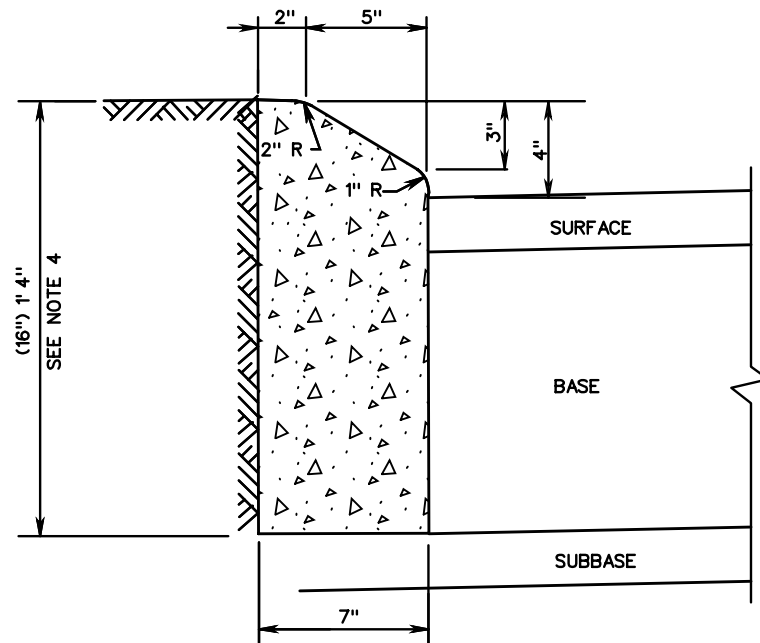

NOTES:

1. THIS ITEM MAY BE PRECAST OR CAST IN PLACE.
2. CONCRETE TO BE CLASS A3 IF CAST IN PLACE, 4000 PSI IF PRECAST.
3. CURB HAVING A RADIUS OF 300 FEET OR LESS (ALONG FACE OF CURB) WILL BE PAID FOR AS RADIAL CURB.
4. THE DEPTH OF CURB MAY BE REDUCED AS MUCH AS 3" (13" DEPTH) OR INCREASED AS MUCH AS 3" (19" DEPTH) IN ORDER THAT THE BOTTOM OF THE CURB WILL COINCIDE WITH THE TOP OF A COURSE OF THE PAVEMENT SUBSTRUCTURE. OTHERWISE, THE DEPTH IS TO BE 16" AS SHOWN. NO ADJUSTMENT IN THE PRICE BID IS TO BE MADE FOR A DECREASE OR AN INCREASE IN DEPTH.
5. CG-3 IS TO BE USED ON ROADWAYS MEETING THE REQUIREMENTS FOR CG-7 AS SHOWN IN APPENDIX A OF THE VDOT ROAD DESIGN MANUAL IN THE SECTION ON GS URBAN STANDARDS.
6. WHEN THIS STANDARD IS TO BE TIED INTO EXISTING BARRIER CURB, THE TRANSITION IS TO BE MADE WITHIN 10' OR THE CHANGE IN STANDARDS CAN BE MADE AT REGULAR OPENINGS.



ROAD AND BRIDGE STANDARDS

STANDARD 4" CURB

SPECIFICATION
REFERENCE

SHEET 1 OF 1

REVISION DATE

VIRGINIA DEPARTMENT OF TRANSPORTATION

201.02

105
502

NOTES:

1. THIS ITEM MAY BE PRECAST OR CAST IN PLACE.
2. CONCRETE TO BE CLASS A3 IF CAST IN PLACE, 4000 PSI IF PRECAST.
3. COMBINATION CURB & GUTTER HAVING A RADIUS OF 300 FEET OR LESS (ALONG FACE OF CURB) SHALL BE PAID FOR AS RADIAL COMBINATION CURB & GUTTER.
4. FOR USE WITH STABILIZED OPEN-GRADED DRAINAGE LAYER, THE BOTTOM OF THE CURB & GUTTER SHALL BE CONSTRUCTED PARALLEL TO THE SLOPE OF SUBBASE COURSES AND TO THE DEPTH OF THE PAVEMENT.
5. ALLOWABLE CRITERIA FOR THE USE OF CG-6 IS BASED ON ROADWAY CLASSIFICATION AND DESIGN SPEED AS SHOWN IN APPENDIX A OF THE ROAD DESIGN MANUAL IN THE SECTION ON GS URBAN STANDARDS.

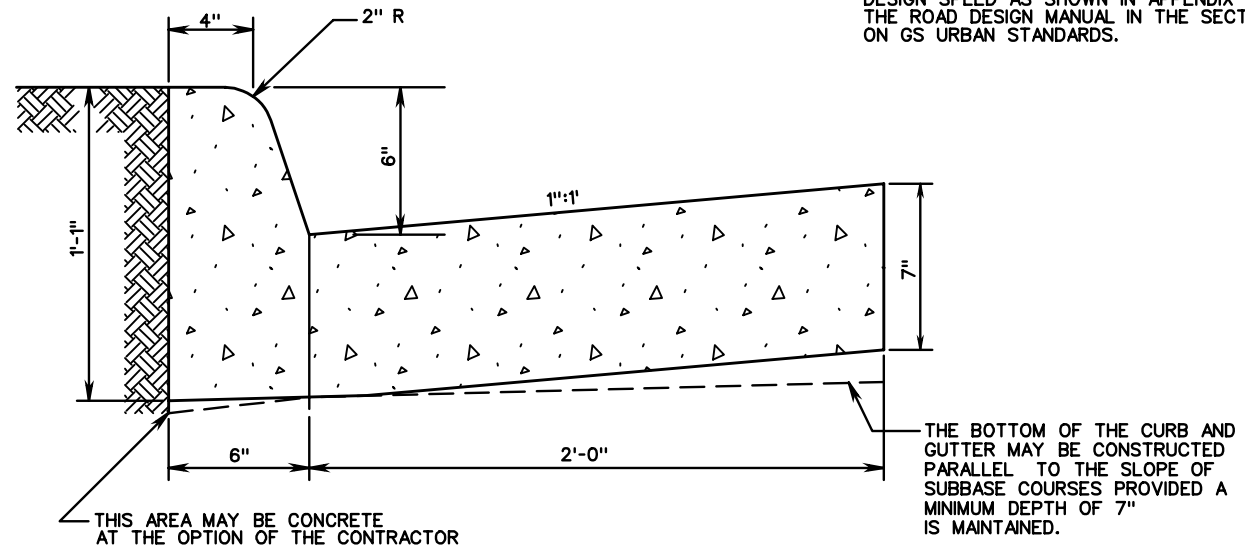

SPECIFICATION REFERENCE
105 502

COMBINATION 6" CURB AND GUTTER

VIRGINIA DEPARTMENT OF TRANSPORTATION

VDOT	
ROAD AND BRIDGE STANDARDS	
REVISION DATE	SHEET 1 OF 1
	201.03

NOTES:

1. THIS ITEM MAY BE PRECAST OR CAST IN PLACE.
2. CONCRETE TO BE CLASS A3 IF CAST IN PLACE, 4000 PSI IF PRECAST.
3. COMBINATION CURB & GUTTER HAVING A RADIUS OF 300 FEET OR LESS (ALONG FACE OF CURB) SHALL BE PAID FOR AS RADIAL COMBINATION CURB & GUTTER.
4. FOR USE WITH STABILIZED OPEN-GRADED DRAINAGE LAYER, THE BOTTOM OF THE CURB AND GUTTER SHALL BE CONSTRUCTED PARALLEL TO THE SLOPE OF SUBBASE COURSES AND TO THE DEPTH OF THE PAVEMENT.
5. ALLOWABLE CRITERIA FOR THE USE OF CG-7 IS BASED ON ROADWAY CLASSIFICATION AND DESIGN SPEED AS SHOWN IN APPENDIX A OF THE VDOT ROAD DESIGN MANUAL IN THE SECTION ON URBAN GS STANDARDS.
6. WHEN THIS STANDARD IS TO BE TIED INTO EXISTING BARRIER CURB, THE TRANSITION IS TO BE MADE WITHIN 10' OR THE CHANGE IN STANDARDS CAN BE MADE AT REGULAR OPENINGS.
7. WHEN COMBINATION MOUNTABLE CURB AND GUTTER IS USED, THE STANDARD ENTRANCE GUTTERS OR STANDARD CONNECTION FOR STREET INTERSECTIONS ARE TO HAVE THE MOUNTABLE CURB CONFIGURATION INCORPORATED.

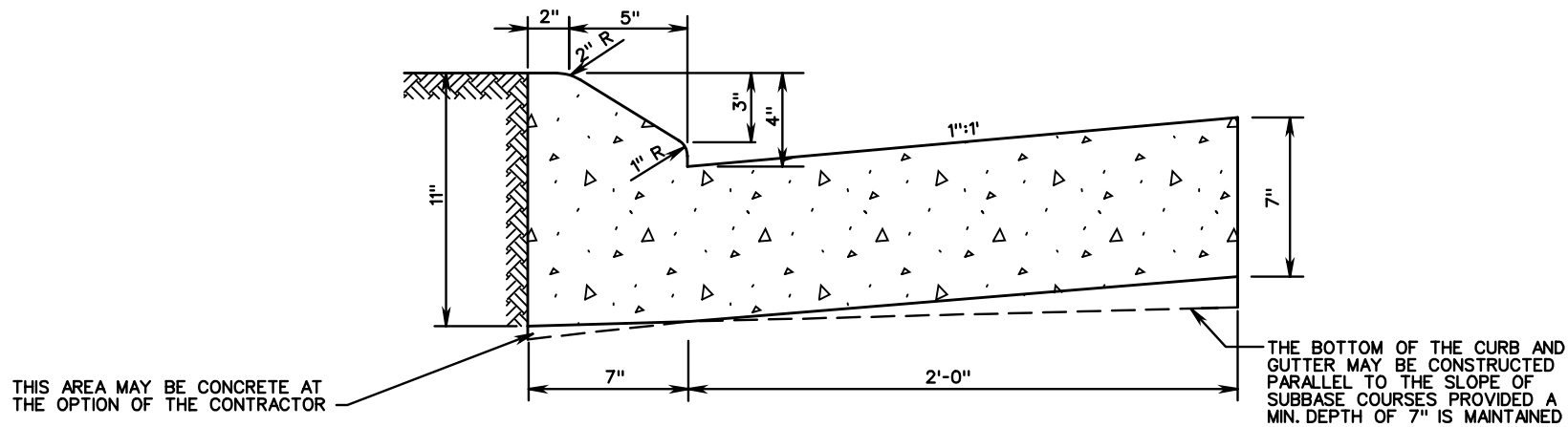

ROAD AND BRIDGE STANDARDS

SHEET 1 OF 1

REVISION DATE

201.04

COMBINATION 4" CURB AND GUTTER

VIRGINIA DEPARTMENT OF TRANSPORTATION

SPECIFICATION
REFERENCE105
502

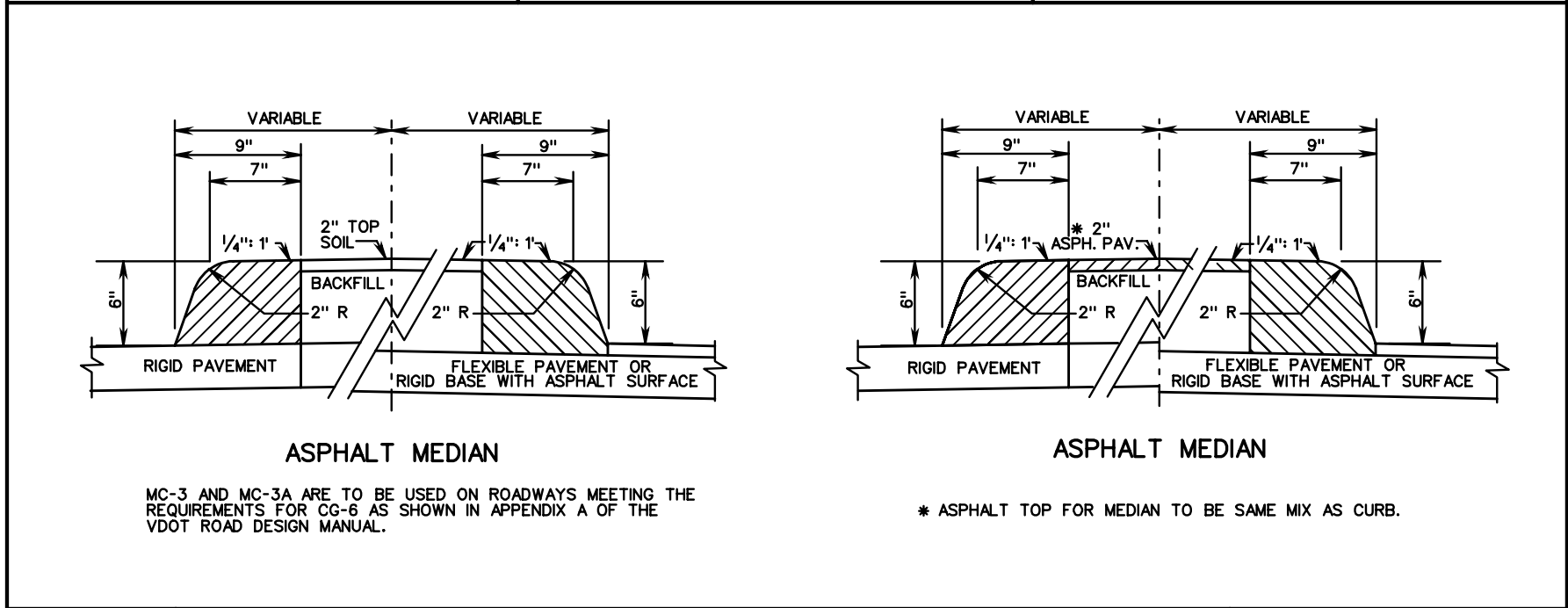
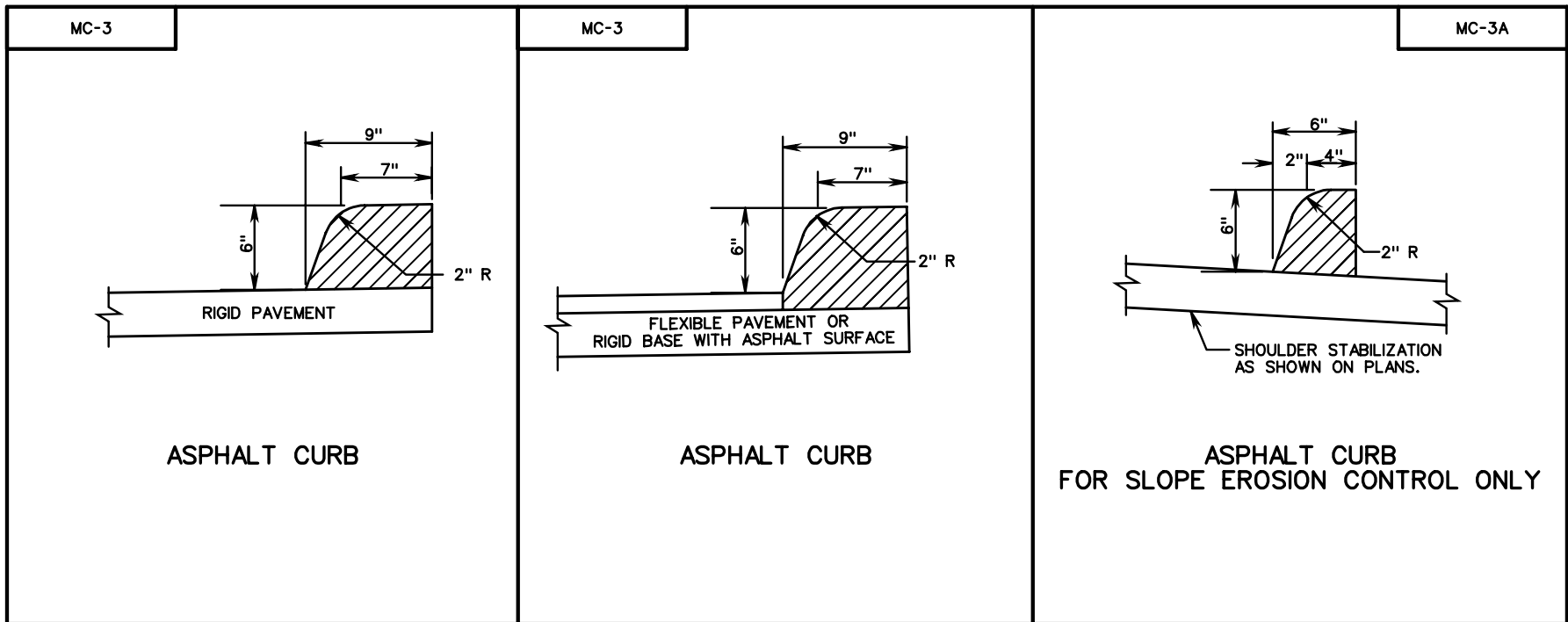

SPECIFICATION REFERENCE	<h2 style="margin: 0;">ASPHALT CONCRETE CURB AND MEDIAN</h2> <p style="margin: 0;">(FOR TEMPORARY OR PERMANENT INSTALLATION)</p> <p style="margin: 0;">VIRGINIA DEPARTMENT OF TRANSPORTATION</p>	 ROAD AND BRIDGE STANDARDS				
502		<table border="1" style="width: 100%; border-collapse: collapse;"> <tr> <td style="width: 50%;">REVISION DATE</td> <td style="width: 50%;">SHEET 1 OF 1</td> </tr> <tr> <td></td> <td style="text-align: center;">201.05</td> </tr> </table>	REVISION DATE	SHEET 1 OF 1		201.05
REVISION DATE	SHEET 1 OF 1					
	201.05					

MC-3B

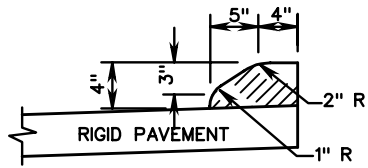

ASPHALT CURB

MC-3B

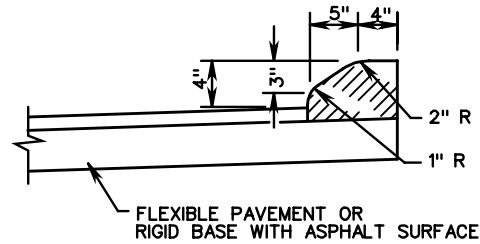

ASPHALT CURB

MC-3C

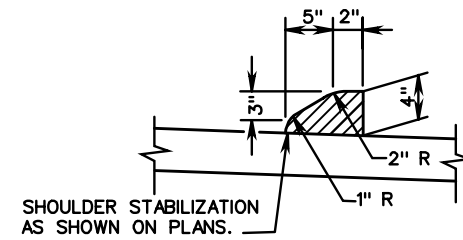

ASPHALT CURB FOR SLOPE EROSION CONTROL ONLY

MC-3B

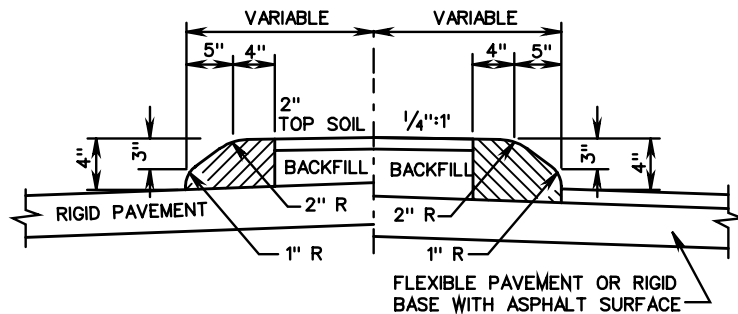

ASPHALT MEDIAN

MC-3B AND MC-3C ARE TO BE USED ON ROADWAYS MEETING THE REQUIREMENTS FOR CG-7 AS SHOWN IN APPENDIX A OF THE VDOT ROAD DESIGN MANUAL IN THE SECTION ON GS STANDARDS.

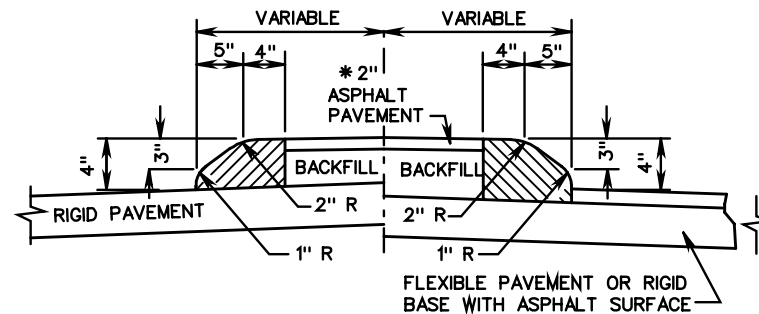

ASPHALT MEDIAN

* ASPHALT TOP FOR MEDIAN TO BE SAME MIX AS CURB.



ROAD AND BRIDGE STANDARDS

SHEET 1 OF 1

REVISION DATE

201.06

ASPHALT CONCRETE CURB AND MEDIAN
(FOR TEMPORARY OR PERMANENT INSTALLATION)

VIRGINIA DEPARTMENT OF TRANSPORTATION

SPECIFICATION REFERENCE

502

LEFT OF TRAFFIC			
SHOULDER WIDTH L	L1	L2	L3
15'	10'	2'	3'
15'	4'	8'	3'
15'	3'	9'	3'
13'	3'	7'	3'
12'	10'	—	2'
11'	3'	5'	3'
8'	4'	2'	2'
8'	3'	3'	2'

RIGHT OF TRAFFIC			
SHOULDER WIDTH R	R1	R2	R3
15'	10'	2'	3'
15'	6'	6'	3'
13'	8'	2'	3'
11'	6'	2'	3'
9'	6'	—	3'

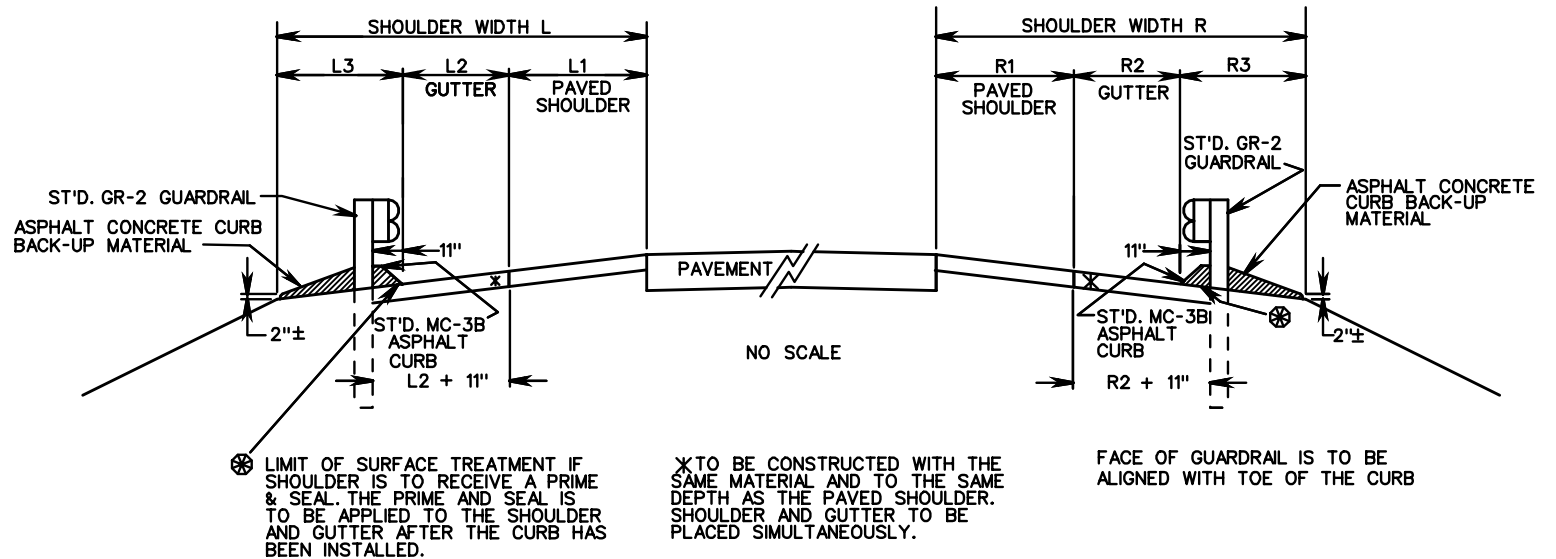

ST'D. GR-2 & MC-3B (11") ASPHALT CURB INSTALLATION

SPECIFICATION REFERENCE

105
502

ASPHALT CURB AND GUTTER (ASPHALT PAVING UNDER GUARDRAIL)

VIRGINIA DEPARTMENT OF TRANSPORTATION

VDOT

ROAD AND BRIDGE STANDARDS

REVISION DATE

SHEET 1 OF 2

201.07

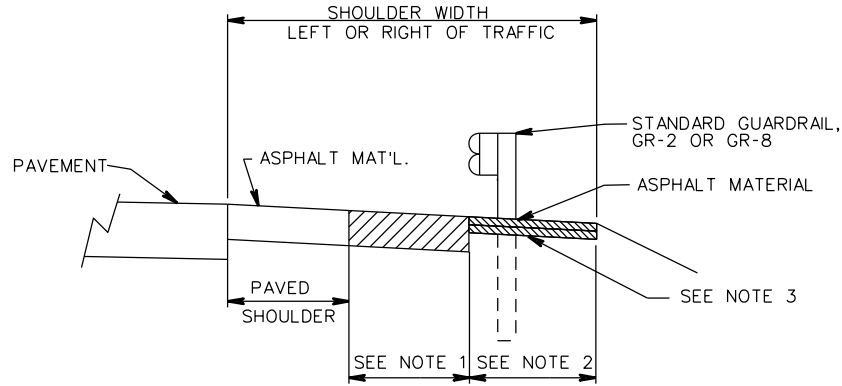

ASPHALT PAVING UNDER GUARDRAIL

(FOR USE WHERE ASPHALT CURB IS NOT REQUIRED)

NOTES:

1. TO BE CONSTRUCTED WITH THE SAME MATERIAL AND TO THE SAME DEPTH AS THE ROADWAY PAVED SHOULDER.
2. TO BE CONSTRUCTED WITH THE SAME ASPHALT MATERIALS AS THE PAVED SHOULDER TO THE FOLLOWING DEPTHS:

ALLOWABLE DEPTHS OF ASPHALT MATERIAL	
IM-19.0A OR IM-19.0D	2" MIN
BM-25.0	3" MIN
3. DEPTH OF ASPHALT MATERIAL MAY BE EXTENDED AT THE CONTRACTOR'S OPTION TO COINCIDE WITH THE BOTTOM OF THE PAVED SHOULDER COURSE AT NO INCREASE IN THE QUANTITY OF ASPHALT MATERIAL COMPUTED USING THE ABOVE SPECIFIED DEPTH.
4. ADDITIONAL 5 FEET ASPHALT PAVING BEYOND POINT WHERE GUARDRAIL CROSSES SHOULDER LINE.
5. FOR ADDITIONAL DESIGN AND PLACEMENT INFORMATION SEE SHEET 1 OF 2.

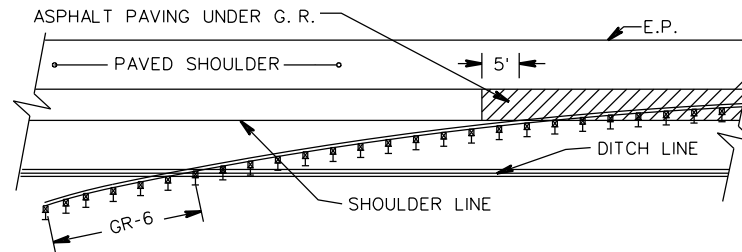

GR-6 TERMINAL

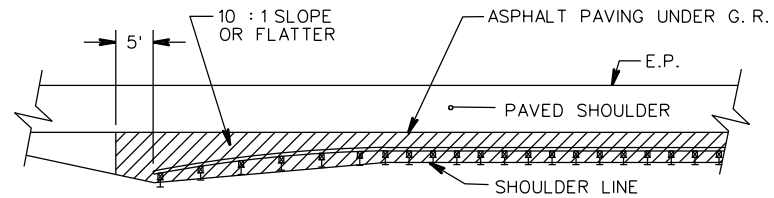

GR-7 & GR-9 TERMINALS

METHODS FOR BEGINNING & ENDING ASPHALT PAVING UNDER GUARDRAIL AND GUARDRAIL INSTALLATION SITE PREPARATION REQUIREMENTS FOR GR-7 AND GR-9 SEE STANDARD.



ROAD AND BRIDGE STANDARDS

SHEET 2 OF 2

REVISION DATE

201.08

7/13

**ASPHALT CURB AND GUTTER
(ASPHALT PAVING UNDER GUARDRAIL)**

VIRGINIA DEPARTMENT OF TRANSPORTATION

SPECIFICATION REFERENCE

105
502

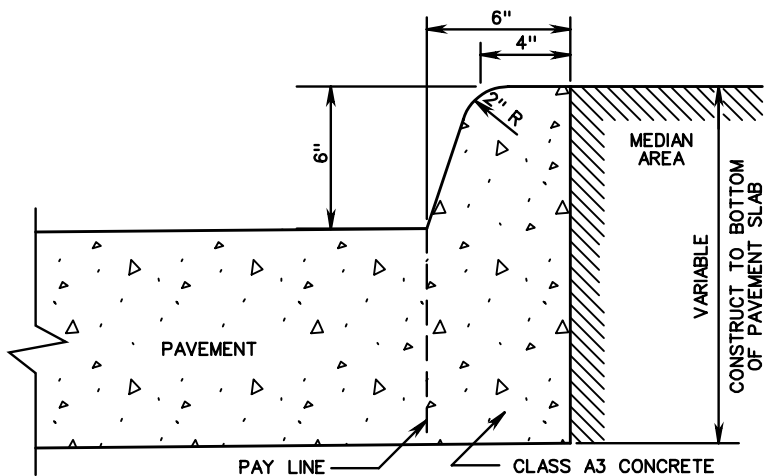

FOR USE WITH CONCRETE PAVEMENT

WHEN ROADWAY DESIGN MEETS THE CRITERIA FOR CG-7 AS SHOWN IN APPENDIX A OF THE ROAD DESIGN MANUAL IN THE SECTION ON GS URBAN STANDARDS, MEDIAN CURB IS TO BE IN ACCORDANCE WITH CG-3.

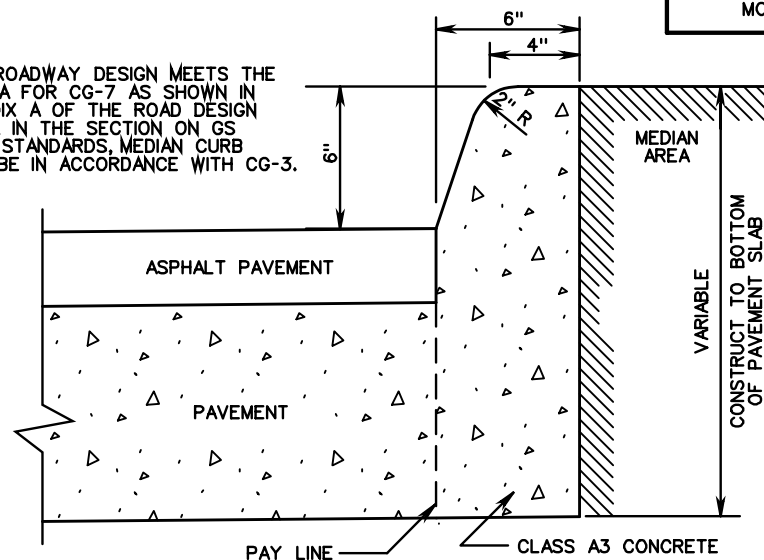

FOR USE WITH CONCRETE WITH ASPHALT TOP COURSE

INTEGRAL

THE DEPTH OF CURB MAY BE REDUCED AS MUCH AS 3" (15" DEPTH) OR INCREASED AS MUCH AS 3" (21" DEPTH) IN ORDER THAT THE BOTTOM OF CURB WILL COINCIDE WITH THE TOP OF A COURSE OF THE PAVEMENT SUBSTRUCTURE. OTHERWISE, THE DEPTH IS TO BE 18" AS SHOWN. NO ADJUSTMENT IN THE PRICE BID IS TO BE MADE FOR A DECREASE OR AN INCREASE IN DEPTH.

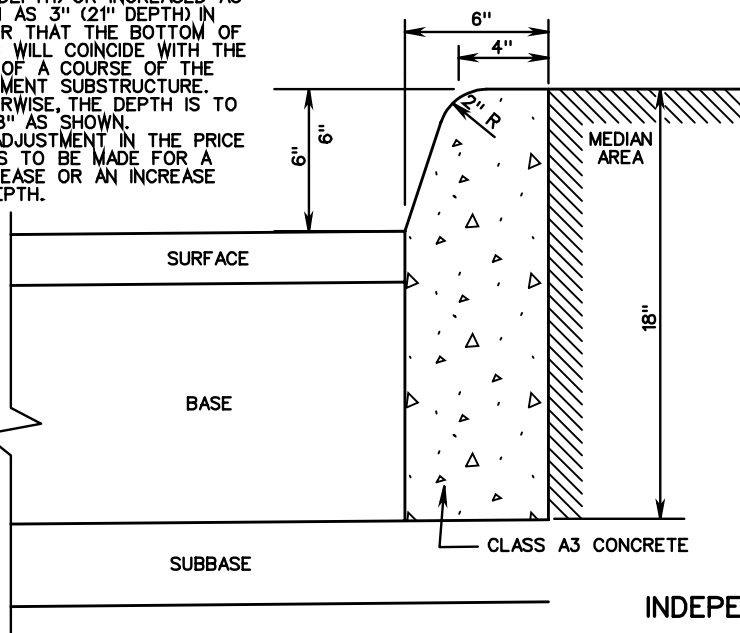

INDEPENDENT

THE DEPTH OF CURB MAY BE REDUCED AS MUCH AS 3" (15" DEPTH) OR INCREASED AS MUCH AS 3" (21" DEPTH) IN ORDER THAT THE BOTTOM OF CURB WILL COINCIDE WITH THE TOP OF A COURSE OF THE PAVEMENT SUBSTRUCTURE. OTHERWISE, THE DEPTH IS TO BE 18" AS SHOWN. NO ADJUSTMENT IN THE PRICE BID IS TO BE MADE FOR A DECREASE OR AN INCREASE IN DEPTH.

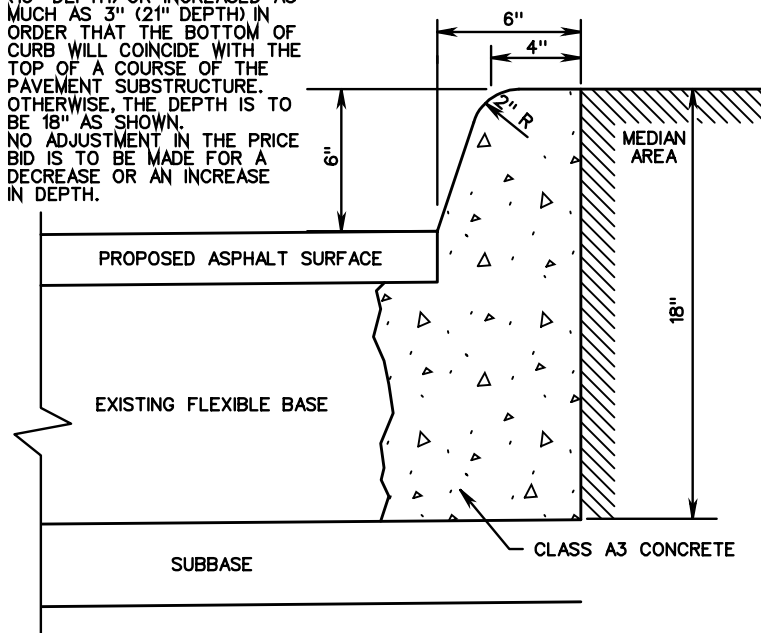

SPECIFICATION REFERENCE

502

CONCRETE MEDIAN CURB

VIRGINIA DEPARTMENT OF TRANSPORTATION

VDOT

ROAD AND BRIDGE STANDARDS

REVISION DATE

SHEET 1 OF 1

202.01

HALF SECTION ON EXISTING CONCRETE PAVEMENT

HALF SECTION ON EXISTING CONCRETE PAVEMENT WITH PROPOSED OR EXISTING ASPHALT PAVEMENT

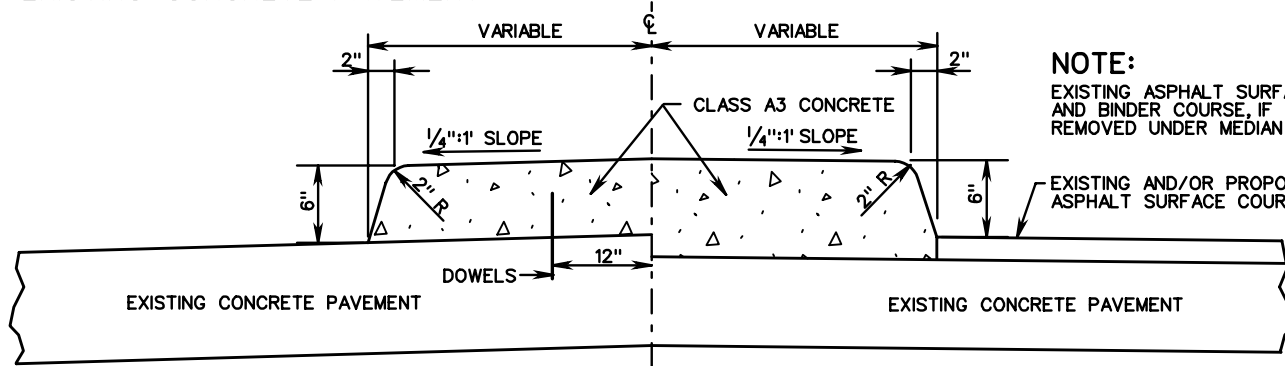

NOTE:
EXISTING ASPHALT SURFACE COURSE AND BINDER COURSE, IF ANY, TO BE REMOVED UNDER MEDIAN STRIP.

EXISTING AND/OR PROPOSED ASPHALT SURFACE COURSE

DOWEL SPACING LOGITUDINALLY AT 2'-0" C-C FROM NOSE TO FIRST JOINT.

WHEN ROADWAY DESIGN MEETS THE CRITERIA FOR CG-7 AS SHOWN IN APPENDIX A OF THE ROADWAY DESIGN MANUAL, IN THE GS STANDARDS SECTION, MEDIAN CURB IS TO BE IN ACCORDANCE WITH CG-3.

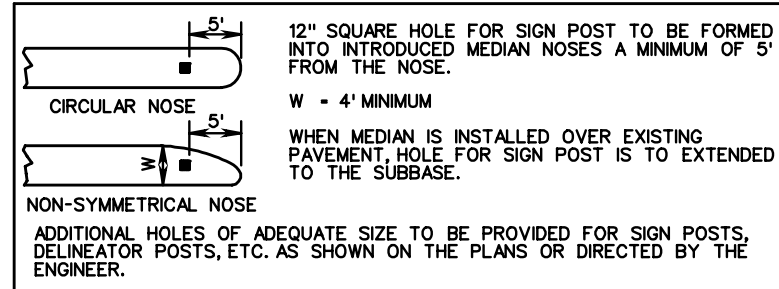

NOTE: EXISTING ASPHALT SURFACE COURSE AND BINDER COURSE, IF ANY, TO BE REMOVED UNDER MEDIAN STRIP.

NOTE:
EXISTING ASPHALT SURFACE COURSE AND BINDER COURSE, IF ANY, TO BE REMOVED UNDER MEDIAN STRIP.

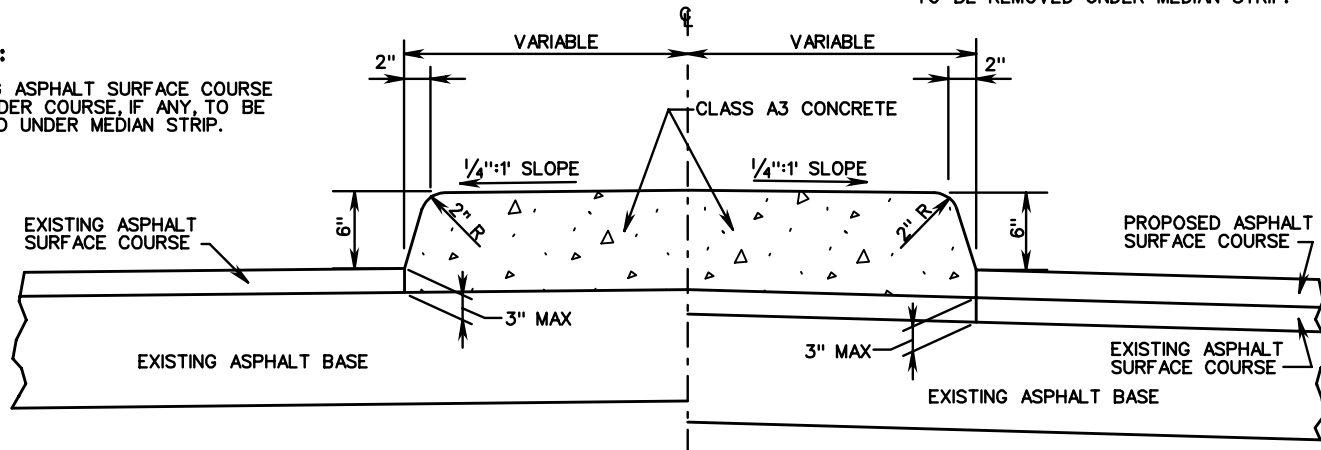

HALF SECTION ON EXISTING FLEXIBLE PAVEMENT

HALF SECTION ON EXISTING FLEXIBLE PAVEMENT TO BE RESURFACED



ROAD AND BRIDGE STANDARDS

STANDARD SOLID CONCRETE RAISED MEDIAN STRIP

SPECIFICATION REFERENCE

SHEET 1 OF 1

REVISION DATE

202.02

VIRGINIA DEPARTMENT OF TRANSPORTATION

502

NOTES:

(1) THOROUGHLY COMPACTED AREA TO CONSIST OF THE FOLLOWING:

IN FILLS - REGULAR FILL MATERIAL

IN CUTS - UNDISTURBED EARTH AND REGULAR FILL MATERIAL AS REQUIRED.

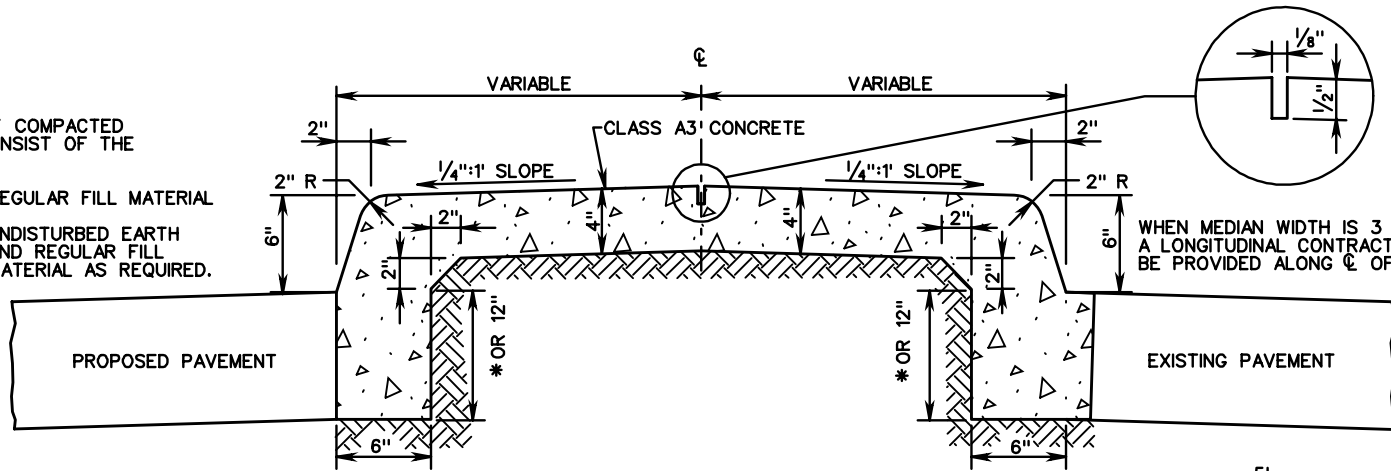

WHEN MEDIAN WIDTH IS 3 FEET OR GREATER, A LONGITUDINAL CONTRACTION JOINT SHALL BE PROVIDED ALONG C OF MEDIAN STRIP.

SUGGESTED CONSTRUCTION METHOD IF TOP SLAB IS POURED SEPARATELY

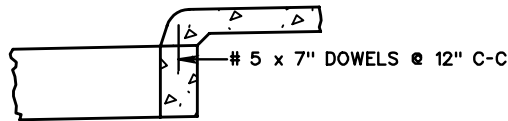

ALTERNATE CONSTRUCTION METHOD IF TOP SLAB IS POURED SEPARATELY

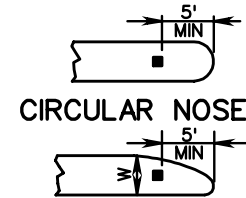
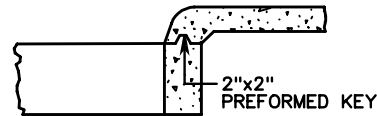

12" SQUARE HOLE FOR SIGN POST TO BE FORMED INTO INTRODUCED MEDIAN NOSES A MINIMUM OF 5' FROM THE NOSE.

W - 4' MIN

NON-SYMMETRICAL NOSE

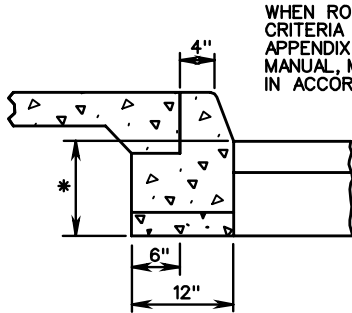

ALTERNATE WITH EXTRUDED CURB

WHEN ROADWAY DESIGN MEETS THE CRITERIA FOR CG-7 AS SHOWN IN APPENDIX A OF THE ROAD DESIGN MANUAL, MEDIAN CURB IS TO BE IN ACCORDANCE WITH STANDARD CG-3.

*THE DEPTH OF CURB MAY BE REDUCED AS MUCH AS 3" (9" DEPTH) OR INCREASED AS MUCH AS 3" (15" DEPTH) IN ORDER THAT THE BOTTOM OF CURB WILL COINCIDE WITH THE TOP OF A COURSE OF THE PAVEMENT STRUCTURE. OTHERWISE, THE DEPTH IS TO BE 12" AS SHOWN. NO ADJUSTMENT IN THE PRICE BID IS TO BE MADE FOR A DECREASE OR AN INCREASE IN DEPTH.

ADDITIONAL HOLES OF ADEQUATE SIZE TO BE PROVIDED FOR SIGN POSTS, DELINEATOR POSTS, ETC. AS SHOWN ON THE PLANS OR DIRECTED BY THE ENGINEER.

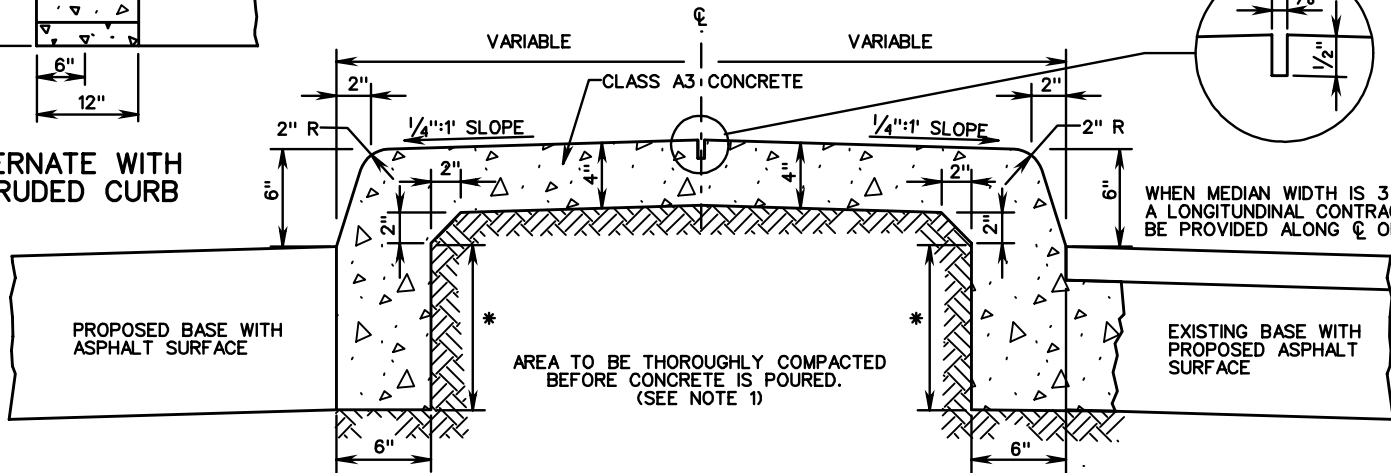

WHEN MEDIAN WIDTH IS 3 FEET OR GREATER A LONGITUDINAL CONTRACTION JOINT SHALL BE PROVIDED ALONG C OF MEDIAN STRIP.

AREA TO BE THOROUGHLY COMPACTED BEFORE CONCRETE IS POURED. (SEE NOTE 1)

SPECIFICATION REFERENCE

502

STANDARD SOLID CONCRETE RAISED MEDIAN STRIP

VIRGINIA DEPARTMENT OF TRANSPORTATION

VDOT

ROAD AND BRIDGE STANDARDS

REVISION DATE

SHEET 1 OF 1

202.03

MS-2

FOR DETAILS OF INTEGRAL CURB
SEE STANDARD MC-1 OR CG-3

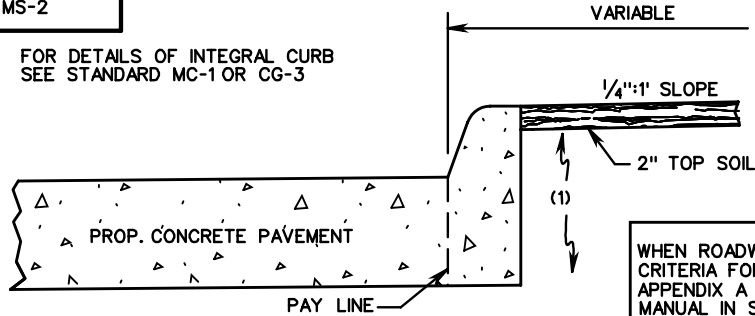

HALF SECTION WITH PROP.
CONCRETE PAVEMENT

WHEN ROADWAY DESIGN MEETS THE
CRITERIA FOR CG-7 AS SHOWN IN
APPENDIX A OF THE ROAD DESIGN
MANUAL IN SECTION ON GS
STANDARDS, MEDIAN CURB IS TO
BE IN ACCORDANCE WITH CG-3

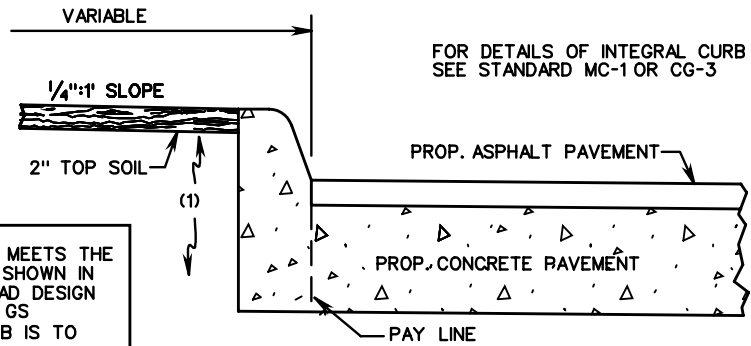

HALF SECTION WITH PROP. CONCRETE
BASE WITH ASPHALT TOP

FOR DETAILS OF INTEGRAL CURB
SEE STANDARD MC-1 OR CG-3

PROP. ASPHALT PAVEMENT

PROP. CONCRETE PAVEMENT

PAY LINE

FOR DETAILS OF INDEPENDENT CURB
SEE STANDARD MC-1 OR CG-3

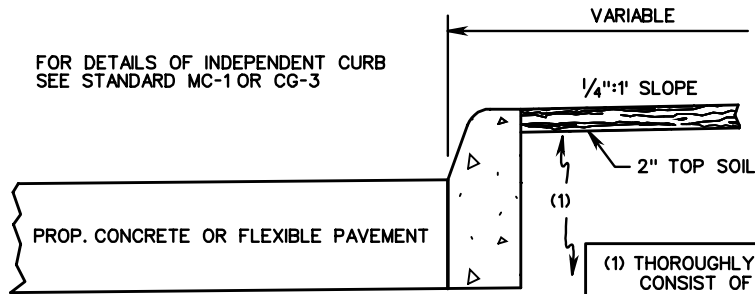

HALF SECTION WITH PROP. CONCRETE
OR FLEXIBLE PAVEMENT

(1) THOROUGHLY COMPACTED AREA TO
CONSIST OF THE FOLLOWING:
IN FILLS - REGULAR FILL MATERIAL
IN CUTS - UNDISTURBED EARTH AND
REGULAR FILL MATERIAL,
AS REQUIRED.
(2) THOROUGHLY COMPACTED AREA TO
CONSIST OF REGULAR FILL MATERIAL.

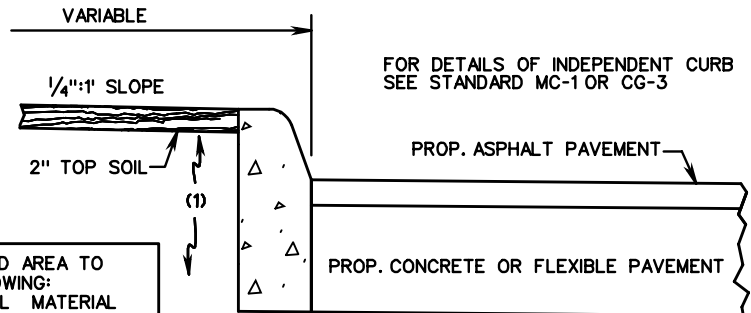

HALF SECTION WITH PROP. CONCRETE OR
FLEXIBLE BASE WITH ASPHALT TOP

FOR DETAILS OF INDEPENDENT CURB
SEE STANDARD MC-1 OR CG-3

PROP. ASPHALT PAVEMENT

PROP. CONCRETE OR FLEXIBLE PAVEMENT

FOR DETAILS OF INDEPENDENT CURB
SEE STANDARD MC-1 OR CG-3

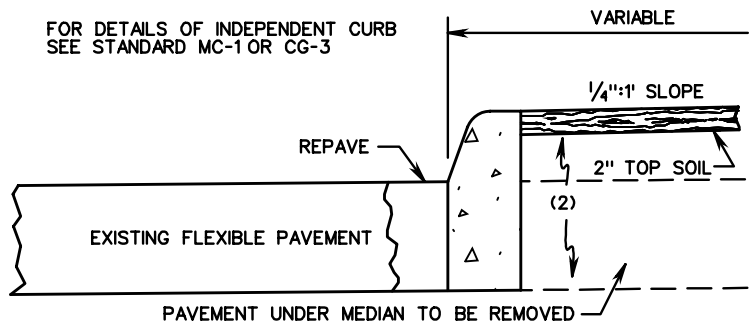

HALF SECTION WITH EXISTING FLEXIBLE PAVEMENT

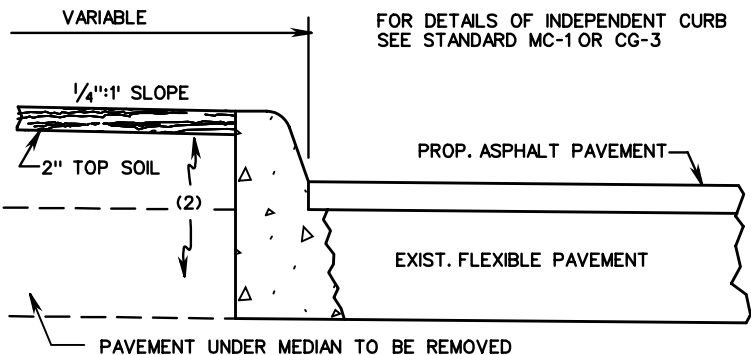

HALF SECTION WITH EXIST. FLEXIBLE BASE
WITH ASPHALT TOP

FOR DETAILS OF INDEPENDENT CURB
SEE STANDARD MC-1 OR CG-3

PROP. ASPHALT PAVEMENT

EXIST. FLEXIBLE PAVEMENT

PAVEMENT UNDER MEDIAN TO BE REMOVED



ROAD AND BRIDGE STANDARDS

SHEET 1 OF 1

REVISION DATE

202.04

STANDARD RAISED GRASS MEDIAN STRIPS

VIRGINIA DEPARTMENT OF TRANSPORTATION

SPECIFICATION
REFERENCE

502

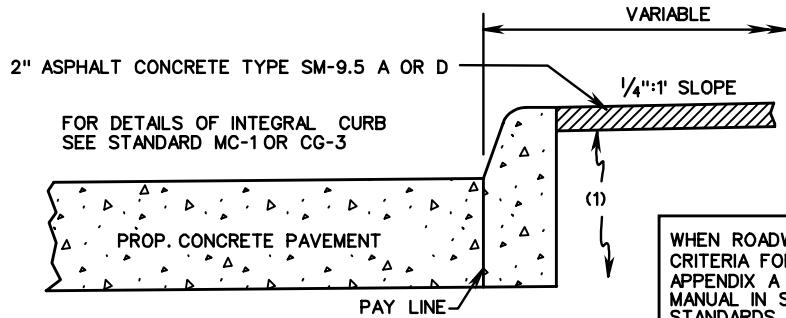

HALF SECTION WITH PROPOSED CONCRETE PAVEMENT

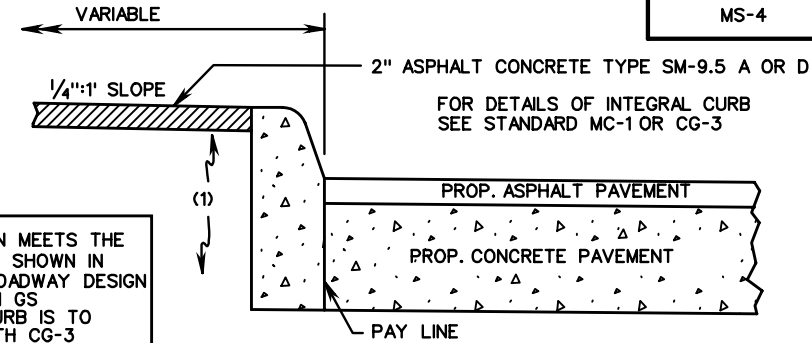

HALF SECTION WITH PROPOSED CONCRETE BASE WITH ASPHALT TOP

WHEN ROADWAY DESIGN MEETS THE CRITERIA FOR CG-7 AS SHOWN IN APPENDIX A OF THE ROADWAY DESIGN MANUAL IN SECTION ON GS STANDARDS, MEDIAN CURB IS TO BE IN ACCORDANCE WITH CG-3

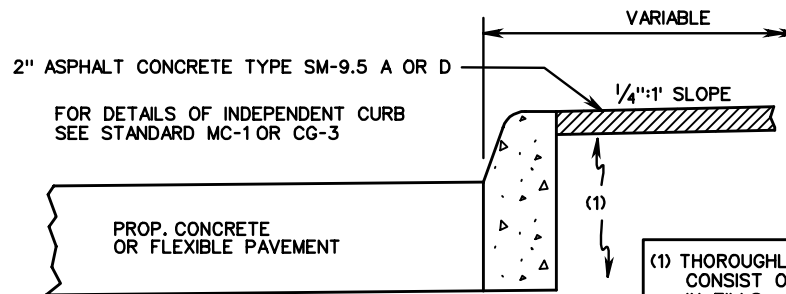

HALF SECTION WITH PROP. CONCRETE OR FLEXIBLE PAVEMENT

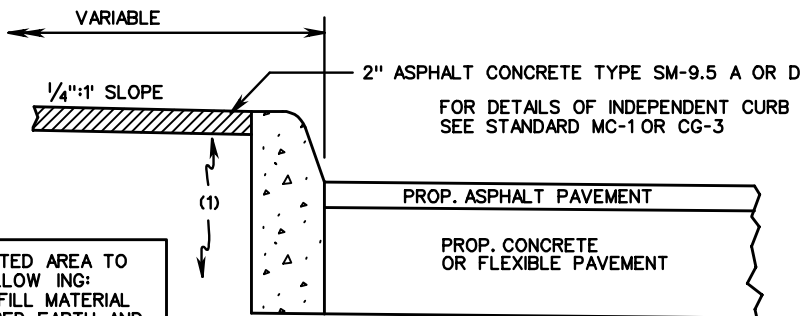

HALF SECTION WITH PROP. CONCRETE OR FLEXIBLE BASE WITH ASPHALT TOP

(1) THOROUGHLY COMPACTED AREA TO CONSIST OF THE FOLLOWING:
 IN FILLS - REGULAR FILL MATERIAL
 IN CUTS - UNDISTURBED EARTH AND REGULAR FILL MATERIAL, AS REQUIRED.
 (2) THOROUGHLY COMPACTED AREA TO CONSIST OF REGULAR FILL MATERIAL.

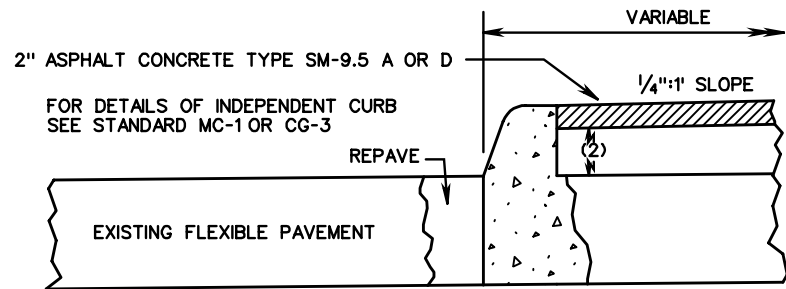

HALF SECTION WITH EXISTING FLEXIBLE PAVEMENT

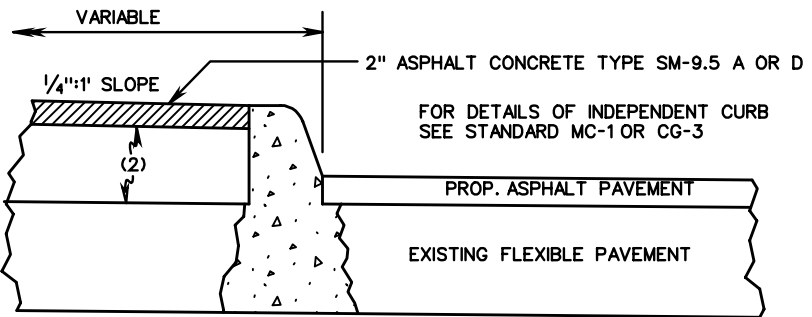

HALF SECTION WITH EXISTING FLEXIBLE BASE WITH ASPHALT TOP

NOTE: THE ASPHALT CONCRETE SURFACE SLAB IS TO CONFORM TO THE CURRENT ROAD & BRIDGE SPECIFICATIONS FOR SM-9.5 A OR D MATERIAL EXCEPT THAT THE MINIMUM BITUMEN CONTENT IS TO BE 6.5%.

SPECIFICATION REFERENCE
502

STANDARD RAISED ASPHALT MEDIAN
 (WITH P.C. CONCRETE CURB)
 VIRGINIA DEPARTMENT OF TRANSPORTATION

VDOT	
ROAD AND BRIDGE STANDARDS	
REVISION DATE	SHEET 1 OF 1
	202.05

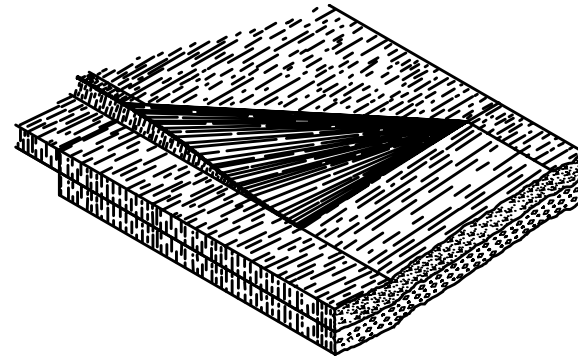
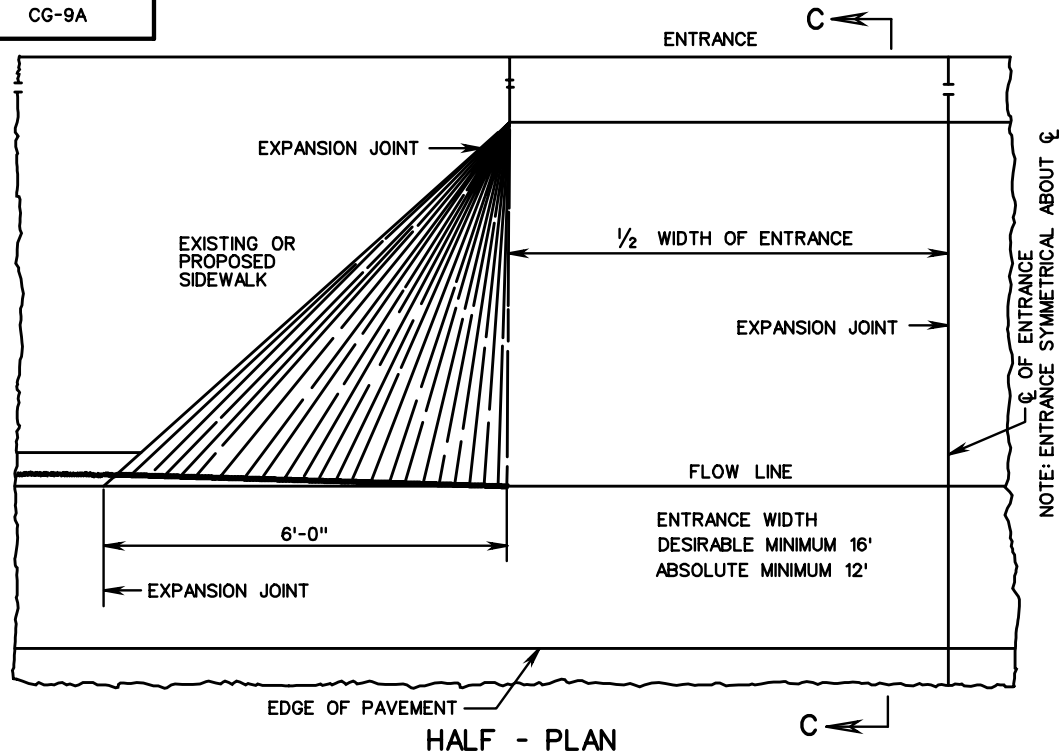

ISOMETRIC VIEW

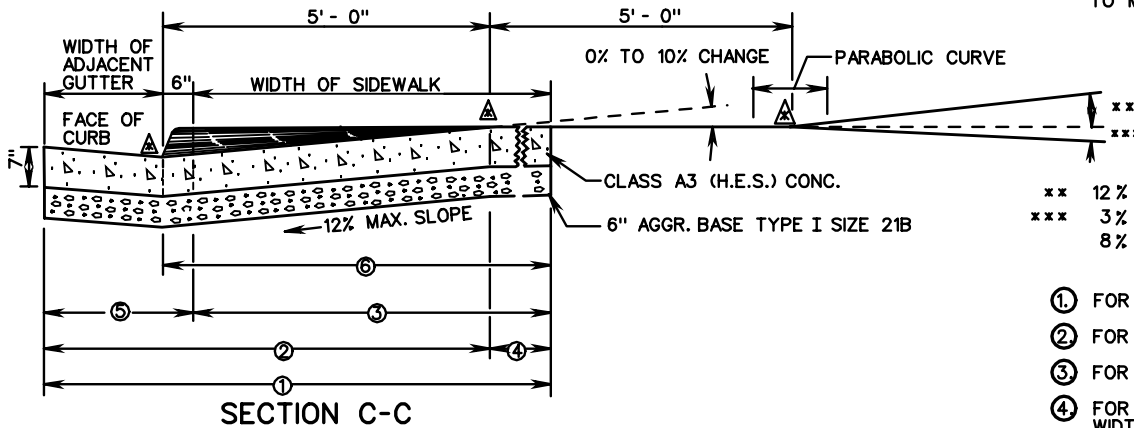

WHEN USED IN CONJUNCTION WITH STANDARD CG-3 OR CG-7, THE CURB FACE ON THIS STANDARD IS TO BE ADJUSTED TO MATCH THE MOUNTABLE CURB CONFIGURATION.

** 12% MAXIMUM INCREASE IN SLOPE AT MINIMUM 10' INTERVALS
 *** 3% MAXIMUM DECREASE IN SLOPE FOR FIRST 10' INTERVAL AND 8% MAXIMUM DECREASE FOR SUCCEEDING MINIMUM 10' INTERVALS

- ① FOR SIDEWALK, CURB AND GUTTER - BUILT CONCURRENTLY.
- ② FOR INITIAL CURB AND GUTTER ONLY.
- ③ FOR INITIAL SIDEWALK ONLY - 7" SIDEWALK TO BE DIPPED.
- ④ FOR PEDESTRIAN ACCESS ROUTE - MINIMUM 4'-0" TRAVERSABLE WIDTH IS REQUIRED WITH A MAXIMUM 2% CROSS SLOPE.
- ⑤ FOR CURB AND GUTTER ONLY - AFTER INITIAL SIDEWALK.
- ⑥ FOR CURB AND SIDEWALK ONLY - WITHOUT GUTTER.
- △ INDICATES POINT OF GRADE CHANGE.



STANDARD ENTRANCE GUTTER WITH FLARED OPENING

(FOR USE ACROSS SIDEWALK)

VIRGINIA DEPARTMENT OF TRANSPORTATION

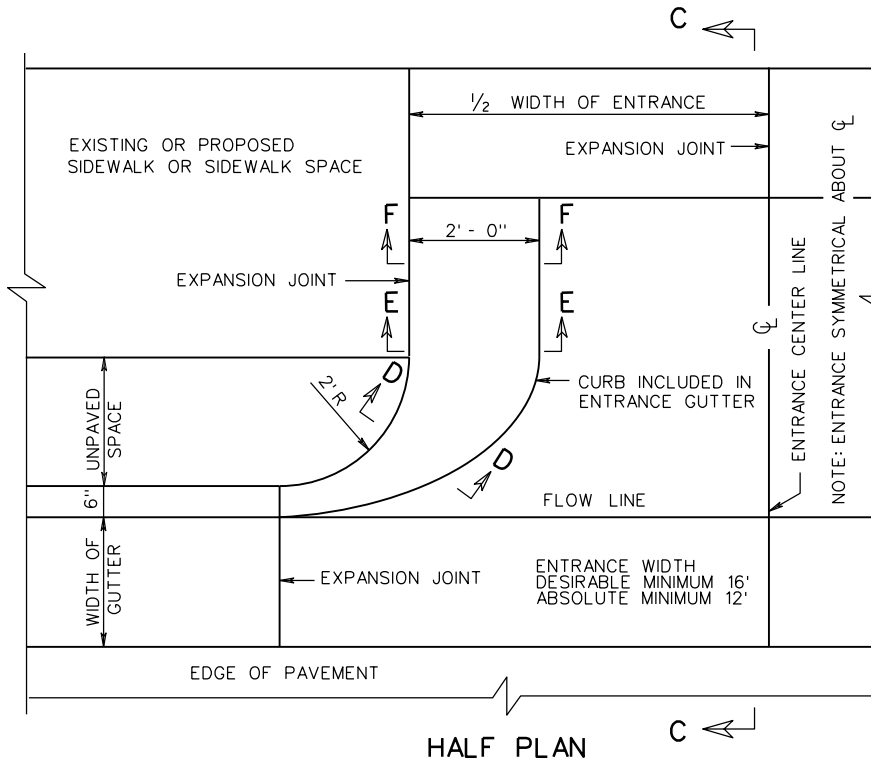

HALF PLAN

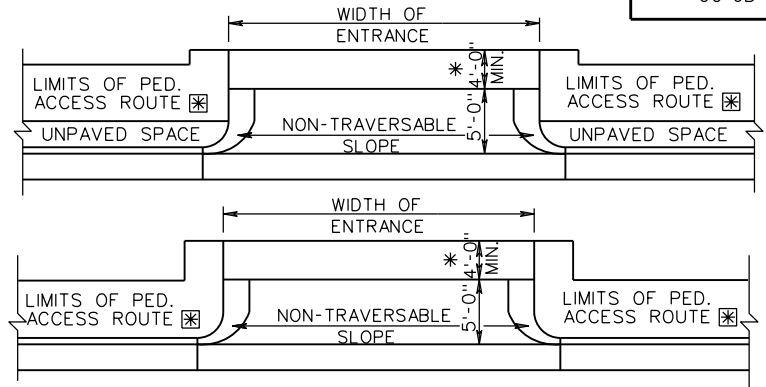

PEDESTRIAN ACCESS ROUTE DETAIL WITH & WITHOUT UNPAVED SPACE

ADDITIONAL RIGHT-OF-WAY IS REQUIRED IF THE LIMITS OF PEDESTRIAN ACCESS ROUTE (X) EXTEND BEYOND EXISTING OR PROPOSED VDOT RIGHT-OF-WAY.

(X) PEDESTRIAN ACCESS ROUTES PROVIDE A CONTINUOUS UNOBSTRUCTED, STABLE, FIRM AND SLIP RESISTANT PATH CONNECTING ALL ACCESSIBLE ELEMENTS OF A FACILITY THAT CAN BE APPROACHED, ENTERED AND USED BY PEDESTRIANS. IF ACCESS ROUTE IS ADJACENT TO BACK OF CURB, MINIMUM WIDTH SHOULD BE 6'.

* IF PEDESTRIAN ACCESS ROUTES (X) ARE BEING PROVIDED, A MINIMUM 4' TRAVERSABLE WIDTH IS REQUIRED WITH A MAX. 2% CROSS SLOPE.

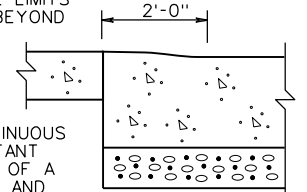

SECTION F-F

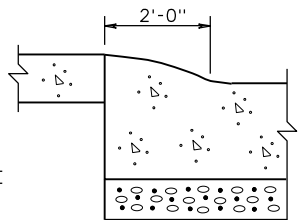

SECTION E-E

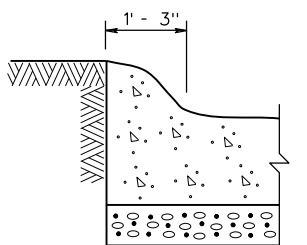

SECTION D-D

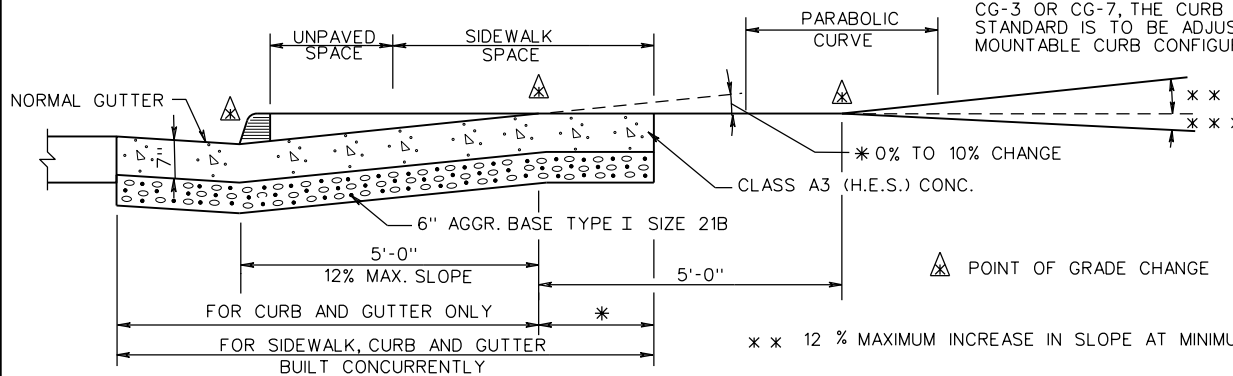

SECTION C-C

WHEN USED IN CONJUNCTION WITH STANDARD CG-3 OR CG-7, THE CURB FACE ON THIS STANDARD IS TO BE ADJUSTED TO MATCH THE MOUNTABLE CURB CONFIGURATION.

- * 0% TO 10% CHANGE
- CLASS A3 (H.E.S.) CONC.
- POINT OF GRADE CHANGE
- ** 12% MAXIMUM INCREASE IN SLOPE AT MINIMUM 10' INTERVALS
- *** 3% MAXIMUM DECREASE IN SLOPE FOR FIRST 10' INTERVAL AND 8% MAXIMUM DECREASE FOR SUCCEEDING MINIMUM 10' INTERVALS

SPECIFICATION REFERENCE
502

STANDARD ENTRANCE GUTTER

VIRGINIA DEPARTMENT OF TRANSPORTATION

VDOT	
ROAD AND BRIDGE STANDARDS	
REVISION DATE	SHEET 1 OF 1
07/15	203.02

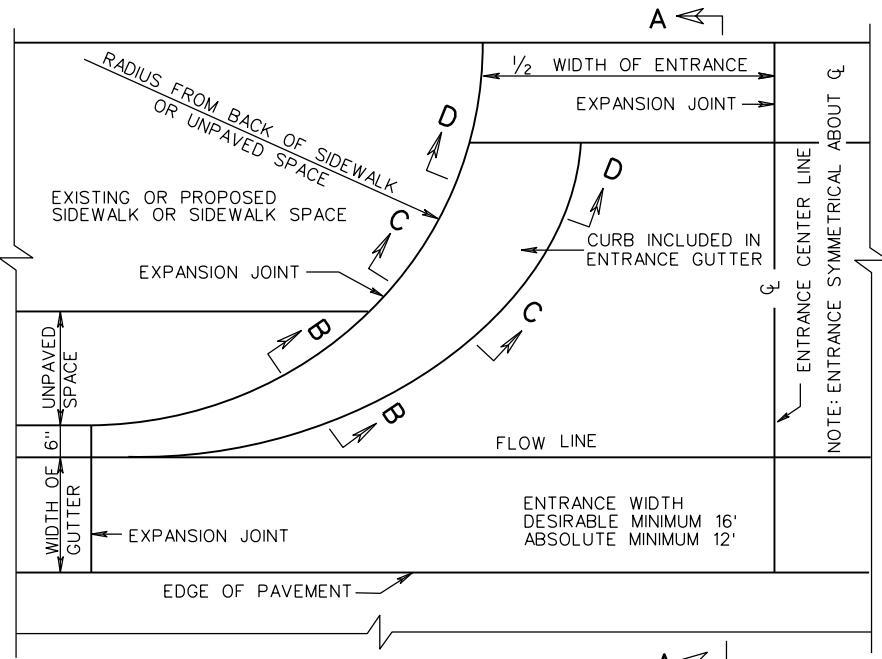

HALF PLAN

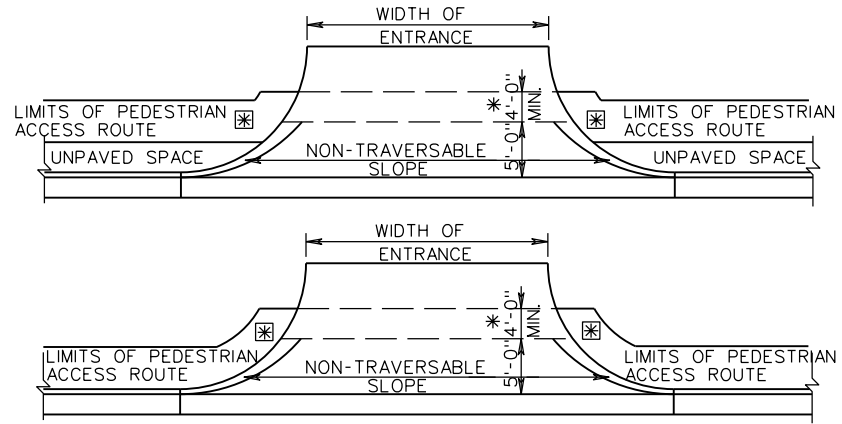

PEDESTRIAN ACCESS ROUTE DETAILS WITH & WITHOUT UNPAVED SPACE

ADDITIONAL RIGHT-OF-WAY IS REQUIRED IF THE LIMITS OF PEDESTRIAN ACCESS ROUTE \boxtimes EXTEND BEYOND EXISTING OR PROPOSED VDOT RIGHT-OF-WAY.

\boxtimes PEDESTRIAN ACCESS ROUTES PROVIDE A CONTINUOUS UNOBSTRUCTED, STABLE, FIRM AND SLIP RESISTANT PATH CONNECTING ALL ACCESSIBLE ELEMENTS OF A FACILITY THAT CAN BE APPROACHED, ENTERED AND USED BY PEDESTRIANS.

* IF PEDESTRIAN ACCESS ROUTES \boxtimes ARE BEING PROVIDED, A MINIMUM 4' TRAVERSABLE WIDTH IS REQUIRED WITH A MAX. 2% CROSS SLOPE.

WHEN USED IN CONJUNCTION WITH STANDARD CG-3 OR CG-7, THE CURB FACE ON THIS STANDARD IS TO BE ADJUSTED TO MATCH THE MOUNTABLE CURB CONFIGURATION.

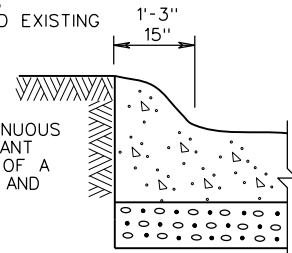

SECTION B-B

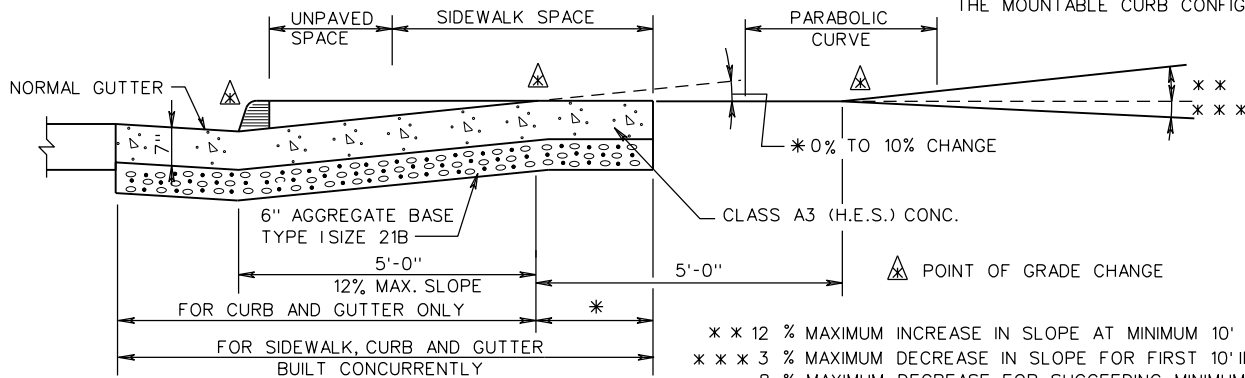

SECTION A-A

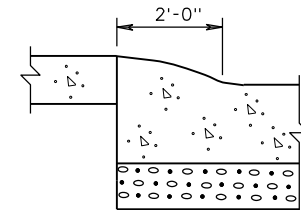

SECTION C-C

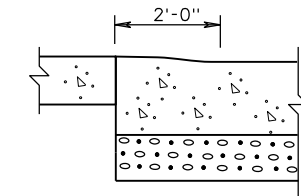

SECTION D-D



ROAD AND BRIDGE STANDARDS

STANDARD ENTRANCE GUTTER

SPECIFICATION REFERENCE

SHEET 1 OF 1

REVISION DATE

502

203.03

07/15

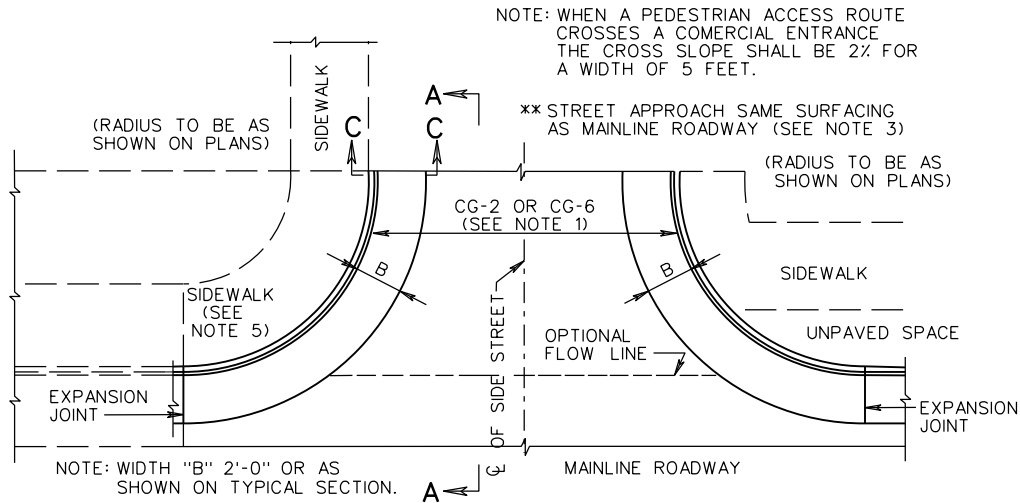

PLAN VIEW

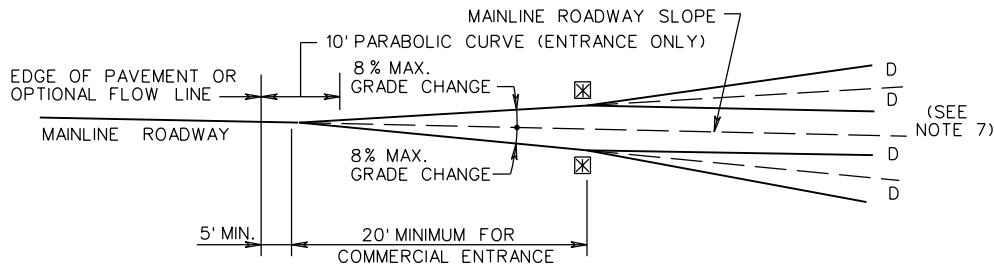

☒ CONSTRUCT GRADE CHANGES WITH A PARABOLIC CURVE.

SECTION A - A

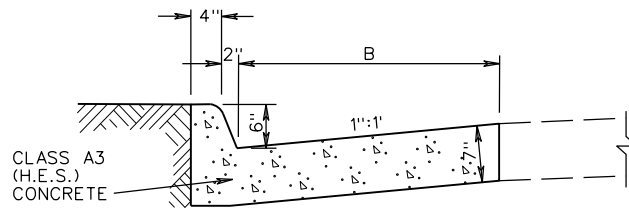

SECTION C-C

GENERAL NOTES

1. WHEN USED IN CONJUNCTION WITH STANDARD CG-3 OR CG-7, THE CURB FACE ON THIS STANDARD IS TO BE ADJUSTED TO MATCH THE MOUNTABLE CURB CONFIGURATION.
2. SEE STANDARD CG-12 FOR CURB RAMP DESIGN TO BE USED WITH THIS STANDARD.
3. MAINLINE PAVEMENT SHALL BE CONSTRUCTED TO THE R/W LINE (EXCEPT ANY SUBGRADE STABILIZATION REQUIRED FOR MAINLINE PAVEMENT WHICH CAN BE OMITTED IN THE ENTRANCE.)
4. RADIAL CURB OR COMBINATION CURB AND GUTTER SHALL NOT BE CONSTRUCTED BEYOND THE R/W LINE EXCEPT FOR REPLACEMENT PURPOSES.

ENTRANCE NOTES

5. WHEN THE ENTRANCE RADII CANNOT ACCOMMODATE THE TURNING REQUIREMENTS OF ANTICIPATED HEAVY TRUCK TRAFFIC, THE DEPTH FOR SIDEWALK & CURB RAMPS WITHIN THE LIMITS OF THE RADII SHOULD BE INCREASED TO 7". (SEE CG-13)
6. PLANS ARE TO INDICATE WHEN CONSTRUCTION OF A FLOW LINE IS REQUIRED TO PROVIDE POSITIVE DRAINAGE ACROSS THE ENTRANCE.
7. THE DESIRABLE AND MAXIMUM ENTRANCE GRADE CHANGES "D" ARE LISTED IN THE ALLOWABLE ENTRANCE GRADE TABLE. THESE VALUES ARE NOT APPLICABLE TO STREET CONNECTIONS.

INTERSECTION NOTES

8. WHEN CG-11 IS USED FOR STREET CONNECTIONS, THE CONNECTION MUST BE DESIGNED IN ACCORDANCE WITH AASHTO POLICY AND THE APPLICABLE REQUIREMENTS OF THE VDOT ROAD DESIGN MANUAL, INCLUDING STOPPING SIGHT DISTANCE AND K VALUE REQUIREMENTS.
9. OPTIONAL FLOWLINE MAY REQUIRE WARPING OF A PORTION OF GUTTER TO PROVIDE POSITIVE DRAINAGE ACROSS THE INTERSECTION.

ALLOWABLE ENTRANCE GRADE CHANGES

ENTRANCE VOLUME		GRADE CHANGE "D"	
		DESIRABLE	MAXIMUM
HIGH	MORE THAN 1500 VPD	0 %	3 %
MEDIUM	500-1500 VPD	≤ 3 %	6 %
LOW	LESS THAN 500 VPD	≤ 6 %	8 %

NOTE: ALLOWABLE ENTRANCE GRADE TABLE IS NOT APPLICABLE TO STREET CONNECTIONS

<p>SPECIFICATION REFERENCE</p>	<p>METHOD OF TREATMENT</p> <p>(CONNECTION FOR STREET INTERSECTIONS AND COMMERCIAL ENTRANCES)</p> <p>VIRGINIA DEPARTMENT OF TRANSPORTATION</p>	<p>VDOT</p> <p>ROAD AND BRIDGE STANDARDS</p>
<p>502</p>		<p>REVISION DATE</p> <p>07/15</p>
		<p>SHEET 1 OF 1</p> <p>203.04</p>

GENERAL NOTES:

1. THE DETECTABLE WARNING SHALL BE PROVIDED BY TRUNCATED DOMES.
2. DETECTABLE WARNING SHALL BE FROM THE MATERIALS APPROVED LIST FOR DETECTABLE WARNING SURFACES. PRODUCTS NOT LISTED SHALL MEET THE REQUIREMENTS OF THE SPECIAL PROVISION FOR CG-12 DETECTABLE WARNING SURFACE AND SHALL BE SUBMITTED TO THE STANDARDS AND SPECIAL DESIGN SECTION FOR APPROVAL.
3. SLOPING SIDES OF CURB RAMP MAY BE POURED MONOLITHICALLY WITH RAMP FLOOR OR BY USING PERMISSIBLE CONSTRUCTION JOINT WITH REQUIRED BARS.
4. IF RAMP FLOOR IS PRECAST, HOLES MUST BE PROVIDED FOR DOWEL BARS SO THAT ADJOINING FLARED SIDES CAN BE CAST IN PLACE AFTER PLACEMENT OF PRECAST RAMP FLOOR. PRECAST CONCRETE SHALL BE CLASS A-4.
5. REQUIRED BARS ARE TO BE NO. 5 X 8" PLACED 1' CENTER TO CENTER ALONG BOTH SIDES OF THE RAMP FLOOR, MID-DEPTH OF RAMP FLOOR. MINIMUM CONCRETE COVER 1/2".
6. CURB / CURB AND GUTTER SLOPE TRANSITIONS ADJACENT TO CURB RAMPS ARE INCLUDED IN PAYMENT FOR CURB / CURB AND GUTTER.
7. CURB RAMPS ARE TO BE LOCATED AS SHOWN ON THE PLANS OR AS DIRECTED BY THE ENGINEER. THEY ARE TO BE PROVIDED AT INTERSECTIONS WHEREVER AN ACCESSIBLE ROUTE WITHIN THE RIGHT OF WAY OF A HIGHWAY FACILITY CROSSES A CURB REGARDLESS OF WHETHER SIDEWALK IS EXISTING, PROPOSED, OR NONEXISTENT. THEY MUST BE LOCATED WITHIN PEDESTRIAN CROSSWALKS AS SHOWN ON PLANS OR AS DIRECTED BY THE ENGINEER, AND SHOULD NOT BE LOCATED BEHIND VEHICLE STOP LINES, EXISTING LIGHT POLES, FIRE HYDRANTS, DROP INLETS, ETC. ACCESSIBLE ROUTES PROVIDE A CONTINUOUS UNOBSTRUCTED, STABLE, FIRM AND SLIP RESISTANT PATH CONNECTING ALL ACCESSIBLE ELEMENTS OF A FACILITY THAT CAN BE APPROACHED, ENTERED AND USED BY PEDESTRIANS.
8. RAMPS MAY BE PLACED ON RADIAL OR TANGENTIAL SECTIONS PROVIDED THAT THE CURB OPENING IS PLACED WITHIN THE LIMITS OF THE CROSSWALK AND THAT THE SLOPE AT THE CONNECTION OF THE CURB OPENING IS PERPENDICULAR TO THE CURB.
9. TYPICAL CONCRETE SIDEWALK IS 4" THICK. WHEN THE ENTRANCE RADIICANNOT ACCOMMODATE THE TURNING REQUIREMENTS OF ANTICIPATED HEAVY TRUCK TRAFFIC, REFER TO STANDARD CG-13, COMMERCIAL ENTRANCE (HEAVY TRUCK TRAFFIC) FOR CONCRETE DEPTH.
10. WHEN CURB RAMPS ARE USED IN CONJUNCTION WITH A SHARED USE PATH, THE MINIMUM WIDTH SHALL BE THE WIDTH OF THE SHARED USE PATH.
11. WHEN ONLY ONE CURB RAMP IS PROVIDED FOR TWO CROSSINGS (DIAGONAL), A 4' x 4' LANDING AREA SHALL BE PROVIDED TO MANEUVER A WHEELCHAIR INTO THE CROSSWALK WITHOUT GOING INTO THE TRAVELWAY. THIS 4' x 4' LANDING AREA MAY INCLUDE THE GUTTER PAN.
12. ALL CASES WHERE CURB RAMPS INTERSECT A RADIAL SECTION OF CURB AT ENTRANCES OR STREET CONNECTIONS THE DETECTABLE WARNING SURFACE SHALL HAVE A FACTORY RADIUS OR BE FIELD -MODIFIED AS RECOMMENDED BY THE MANUFACTURER TO MATCH THE BACK OF CURB.

NOTE: COMPONENTS OF CURB RAMPS CONSIST OF THE FOLLOWING:
 HYDRAULIC CEMENT SIDEWALK (DEPTH IN INCHES, AREA IN SQUARE YARDS)
 CURB WHEN REQUIRED (CG-2 OR CG-3 IN LINEAR FEET)
 DETECTABLE WARNING SURFACE (AREA IN SQUARE YARDS)
 EACH OF THE ABOVE ITEMS IS A SEPARATE PAY ITEM AND SHOULD BE SUMMARIZED FOR EACH CURB CUT RAMP.

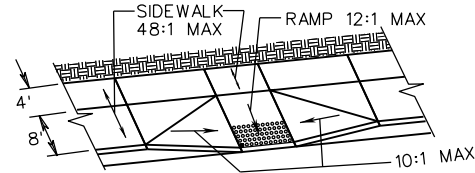

**TYPE A
PERPENDICULAR**

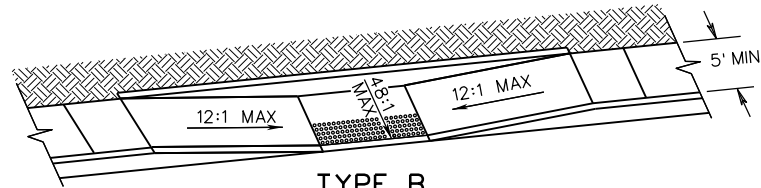

**TYPE B
PARALLEL**

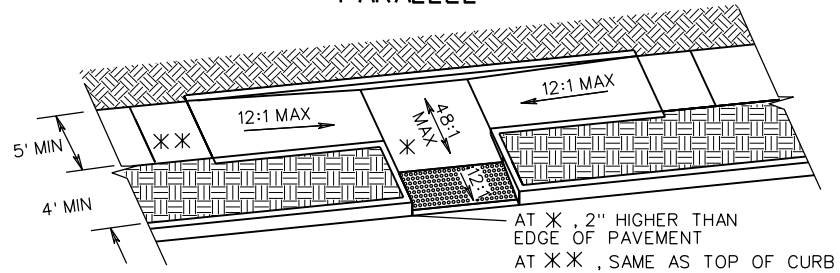

**TYPE C
PARALLEL & PERPENDICULAR**

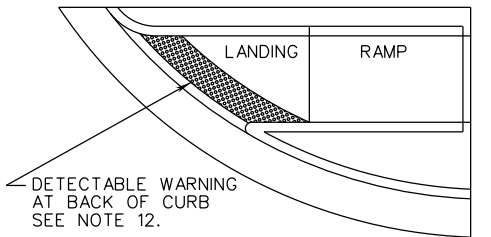

**DETECTABLE WARNING
INSTALLED ON A RADIUS**

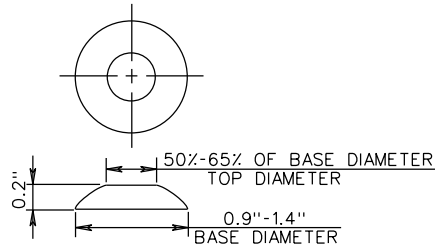

**TRUNCATED DOME
DETAIL**

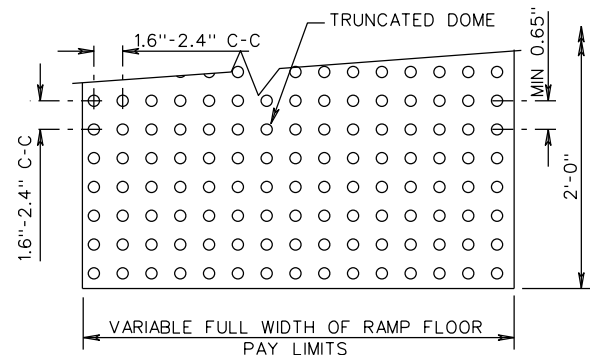

**DETECTABLE WARNING
DETAIL**



ROAD AND BRIDGE STANDARDS

SHEET 1 OF 5

REVISION DATE

203.05

07/15

CG-12 DETECTABLE WARNING SURFACE

(GENERAL NOTES)

VIRGINIA DEPARTMENT OF TRANSPORTATION

SPECIFICATION
REFERENCE

105
502

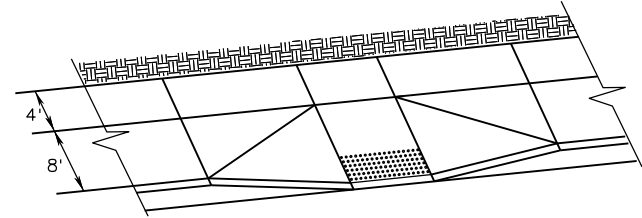
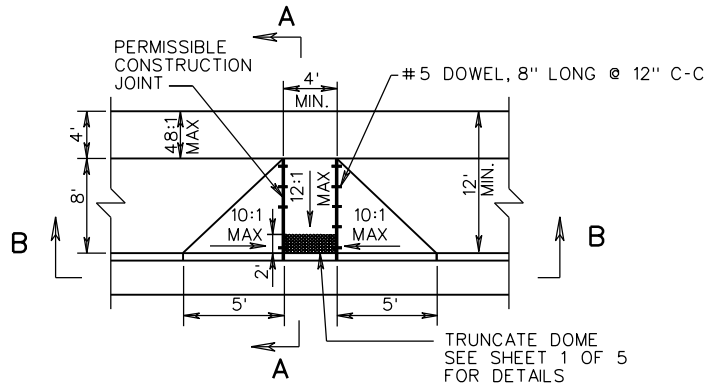

TYPICAL DESIGN

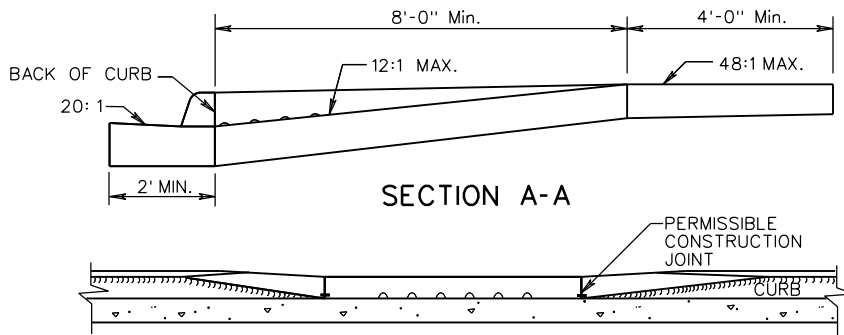

SECTION A-A

SECTION B-B

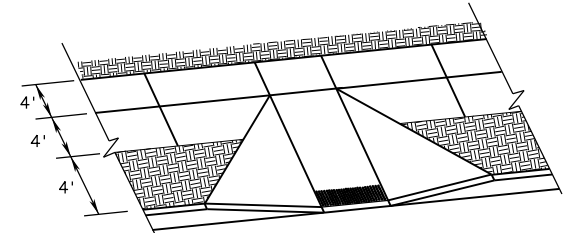

TYPE A WITH BUFFER STRIP

NOTES:
 FOR GENERAL NOTES ON THE DETECTABLE WARNING SURFACE, SEE SHEET 1 OF 5.
 THIS DESIGN TO BE USED FOR CONSTRUCTION THAT INCORPORATES WIDER SIDEWALK. LANDING (4' WIDE) REQUIRED AT TOP OF CURB RAMP. MINIMUM CURB RAMP LENGTH 8 FEET FOR NEW CONSTRUCTION.

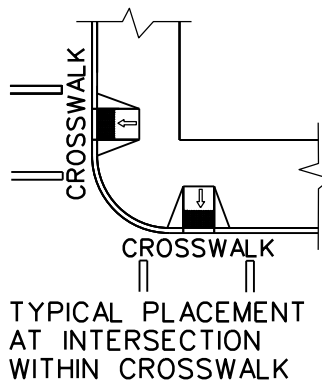

TYPICAL PLACEMENT AT INTERSECTION WITHIN CROSSWALK

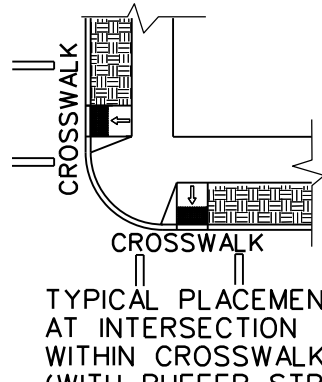

TYPICAL PLACEMENT AT INTERSECTION WITHIN CROSSWALK (WITH BUFFER STRIP)

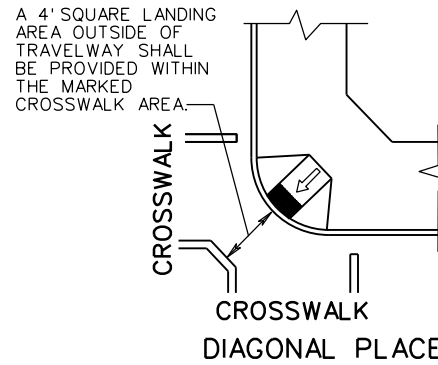

CROSSWALK DIAGONAL PLACEMENT

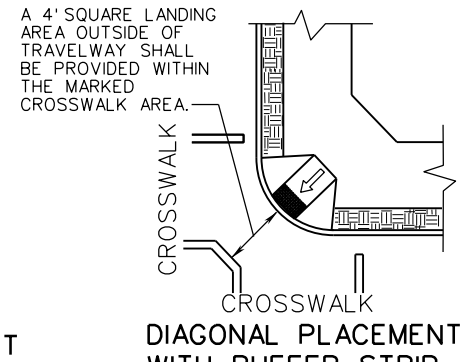

CROSSWALK DIAGONAL PLACEMENT WITH BUFFER STRIP

SPECIFICATION REFERENCE
105 502

CG-12 DETECTABLE WARNING SURFACE
 TYPE A (PERPENDICULAR) APPLICATION

VIRGINIA DEPARTMENT OF TRANSPORTATION

VDOT ROAD AND BRIDGE STANDARDS	
REVISION DATE	SHEET 2 OF 5
07/15	203.06

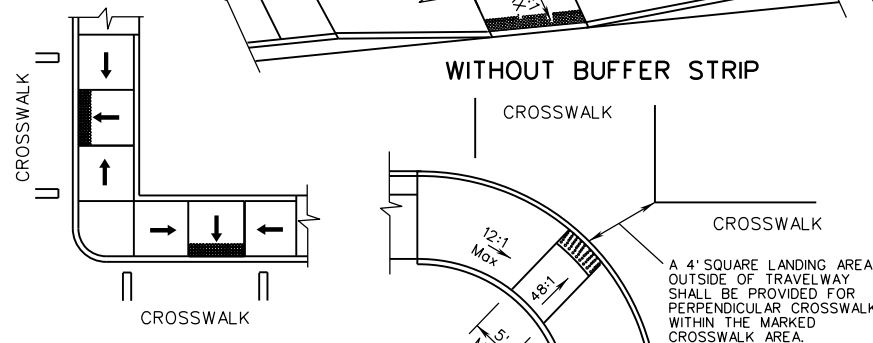
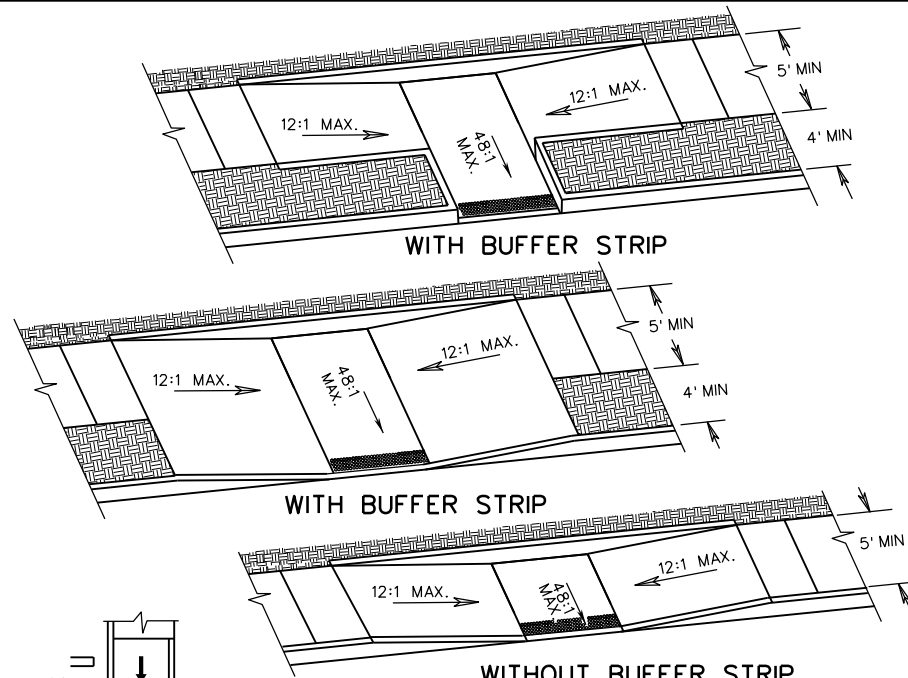
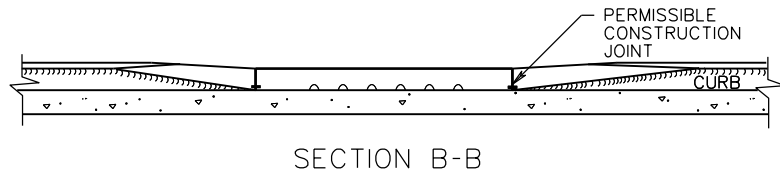
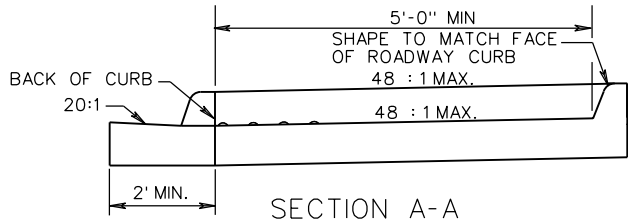
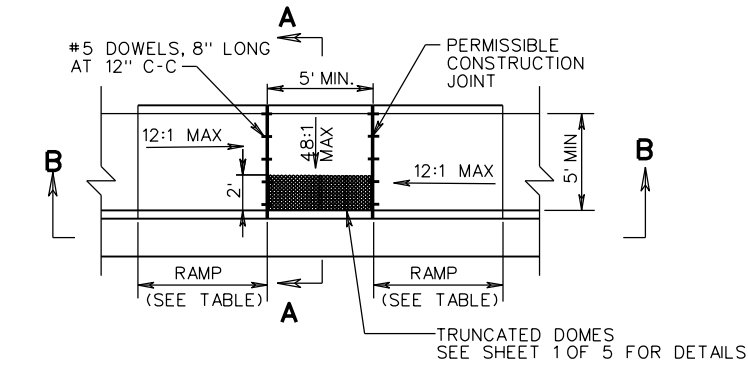

TYPICAL PLACEMENT AT INTERSECTION WITHIN CROSSWALK

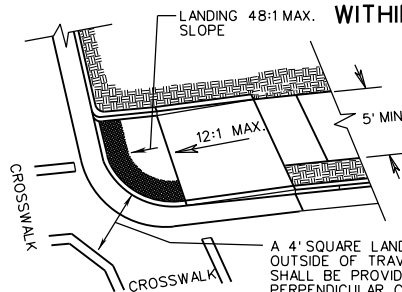

WITH BUFFER STRIP

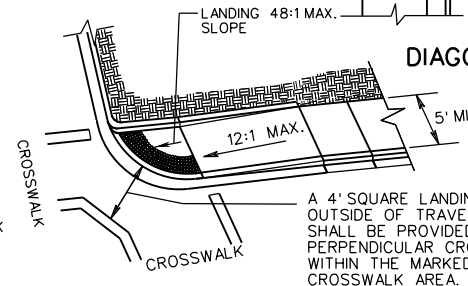

DIAGONAL PLACEMENT

NOTES: FOR GENERAL NOTES ON THE DETECTABLE WARNING SURFACE, SEE SHEET 1 OF 5.

THE REQUIRED LENGTH OF A PARALLEL RAMP IS LIMITED TO 15 FEET, REGARDLESS OF THE SLOPE.

TYPE B PARALLEL APPLICATION		
ROADWAY GRADE IN PERCENT	MINIMUM RAMP LENGTH IN FEET	
	4" CURB	6" CURB
0	4	6
1	5	7
2	5	8
3	6	9
4	8	12
5	10	15
6	14	15



ROAD AND BRIDGE STANDARDS

SHEET 3 OF 5

REVISION DATE

203.07

07/15

CG-12 DETECTABLE WARNING SURFACE

TYPE B (PARALLEL) APPLICATION

VIRGINIA DEPARTMENT OF TRANSPORTATION

SPECIFICATION REFERENCE

105
502

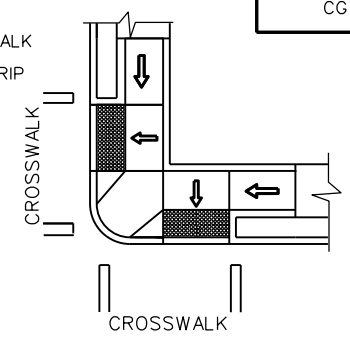
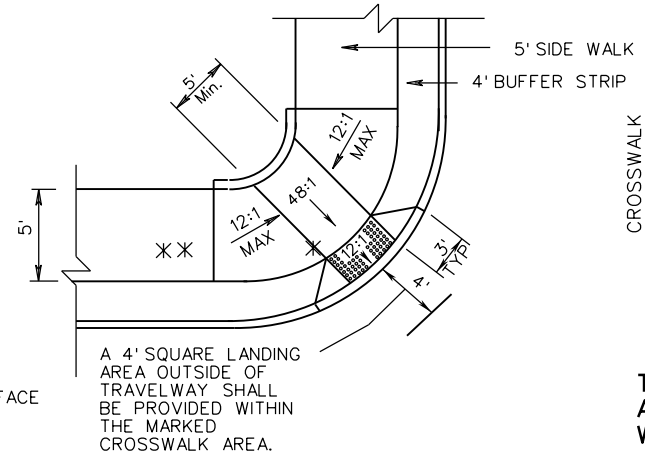
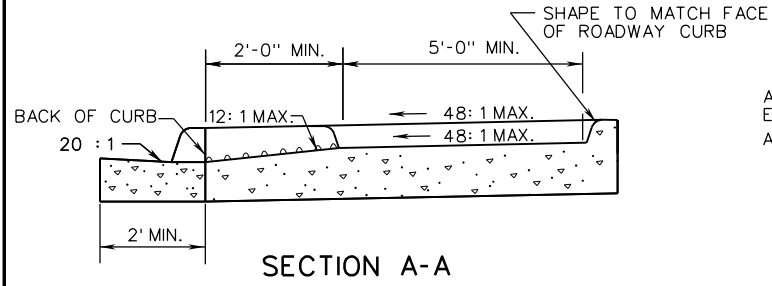
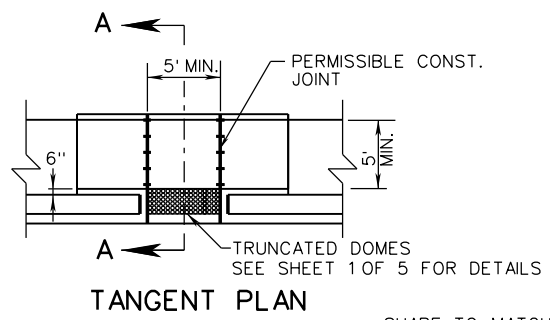

AT ✕, 2" HIGHER THAN EDGE OF PAVEMENT
 AT ✕✕, SAME AS TOP OF CURB

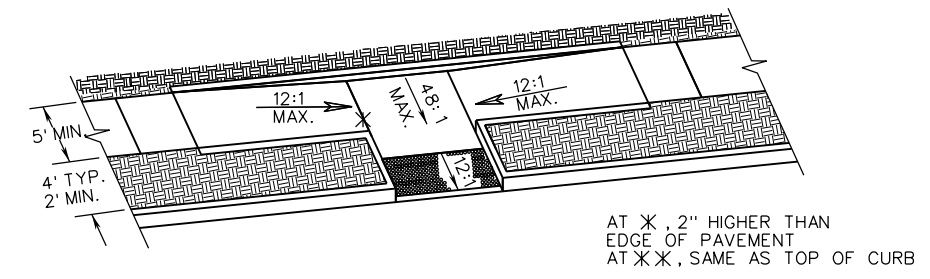
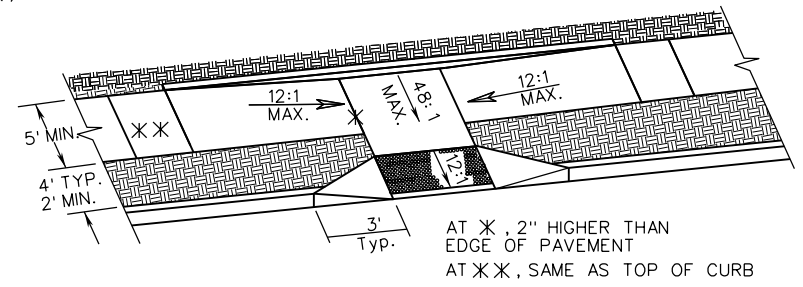

NOTES: FOR GENERAL NOTES ON THE DETECTABLE WARNING SURFACE, SEE SHEET 1 OF 5.

THE SELECTION OF CURB TYPE AND THE CONFIGURATION OF THE BUFFER STRIP MAY VARY TO MEET EXISTING FIELD CONDITIONS AND ROADWAY GEOMETRICS PROVIDING THE DIMENSIONS AND SLOPES ARE AS NOTED.

THIS COMBINED (PARALLEL & PERPENDICULAR) DESIGN CAN BE USED WITH ADJOINING BUFFER STRIP. LANDING AT BOTTOM OF TWO SLOPING SIDES WITH 5' X 5' MIN. DIMENSIONS. THE SHORT PERPENDICULAR RUN TO THE STREET CAN BE PROTECTED BY A LANDSCAPED SETBACK OR CONNECTED TO THE SIDEWALK WITH A WARPED SURFACE.

TYPE C PARALLEL & PERPENDICULAR APPLICATION		
ROADWAY GRADE IN PERCENT	MINIMUM RAMP LENGTH IN FEET	
	4" CURB	6" CURB
0	2	4
1	2	5
2	3	5
3	3	6
4	4	8
5	5	10
6	7	14
7	13	15
8	15	15

THE REQUIRED LENGTH OF A PARALLEL RAMP IS LIMITED TO 15 FEET, REGARDLESS OF THE SLOPE.

SPECIFICATION REFERENCE
105 502

CG-12 DETECTABLE WARNING SURFACE
 TYPE C (PARALLEL & PERPENDICULAR) APPLICATION
 VIRGINIA DEPARTMENT OF TRANSPORTATION

VDOT ROAD AND BRIDGE STANDARDS	
REVISION DATE 07/15	SHEET 4 OF 5 203.08

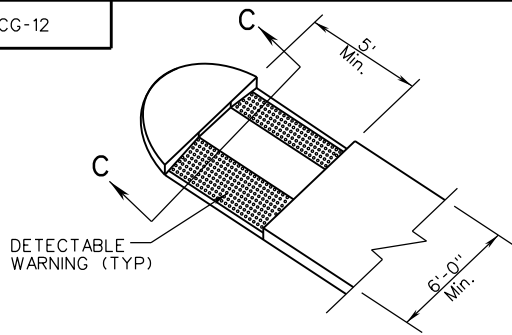

**MEDIAN WITH CUT-THROUGH
TYPE M2**

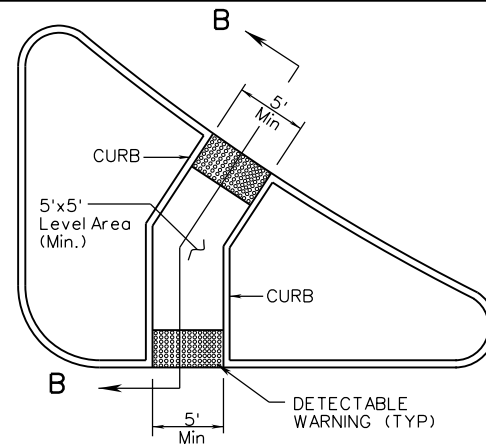
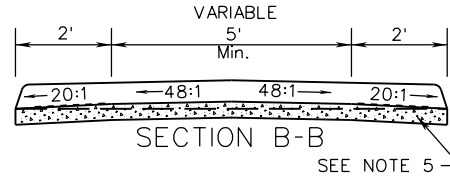
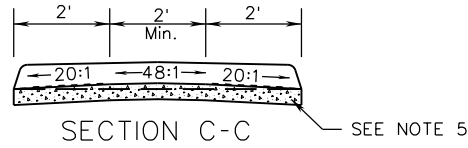

**REFUGE ISLAND WITH RAMPS
TYPE RI1**

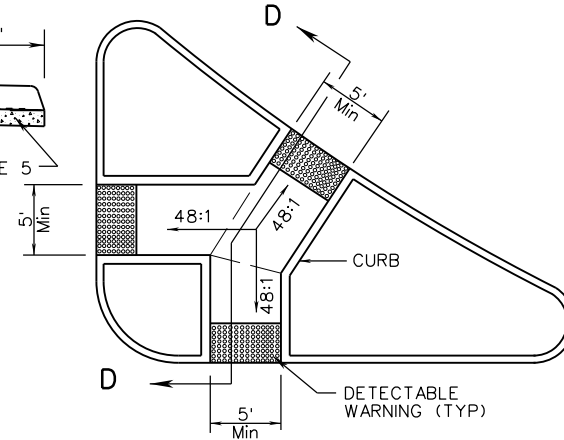
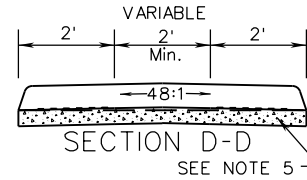

**REFUGE ISLAND CUT - THROUGH
TYPE RI2**

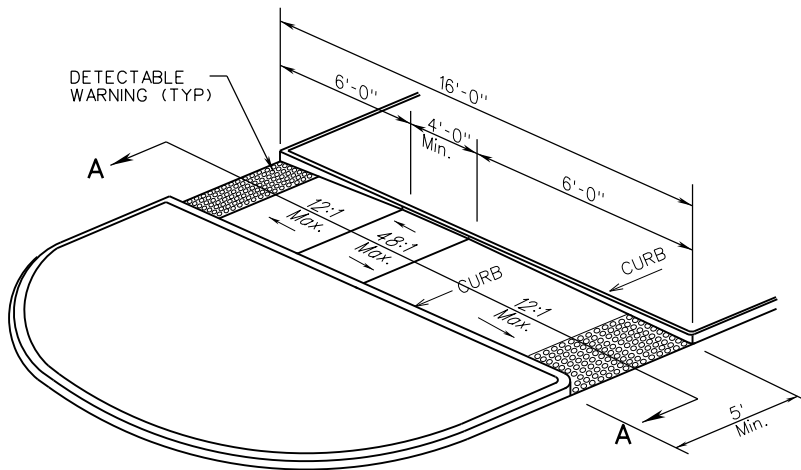

**MEDIAN WITH RAMP
TYPE M1**

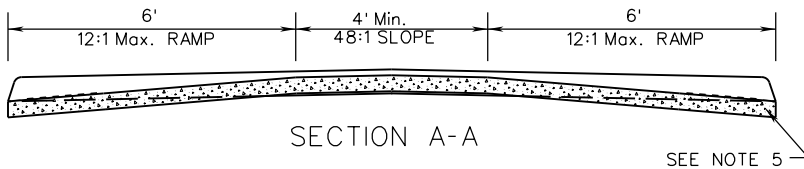

NOTES:

1. FOR GENERAL NOTES ON THE DETECTABLE WARNING SURFACE, SEE SHEET 1 OF 5.
2. CURB SHALL BE SHAPED TO MATCH THE FACE OF ROADWAY CURB.
3. SEE ROADWAY PLANS FOR MEDIAN AND REFUGE ISLAND DIMENSIONS
4. RAMPS AND CUT THROUGH'S SHALL BE ALIGNED WITH CROSSWALKS.
5. THE RAMPS AND CUT THROUGH'S SHALL BE INSTALLED AND PAID FOR AS 4" HYDRAULIC CEMENT CONCRETE SIDEWALK IN ACCORDANCE WITH SECTION 504 OF THE ROAD & BRIDGE SPECIFICATIONS. EXCAVATION OF MATERIAL FOR THE INSTALLATION OF THE SIDEWALK SHALL BE INCLUDED IN THE PRICE BID FOR 4" HYDRAULIC CEMENT CONCRETE SIDEWALK.
6. CUT THROUGH'S LESS THAN 6' IN WIDTH SHALL NOT HAVE DETECTABLE WARNINGS INSTALLED.



ROAD AND BRIDGE STANDARDS

SHEET 5 OF 5

REVISION DATE

203.08A

7/12

CG-12 DETECTABLE WARNING SURFACE

MEDIAN AND REFUGE ISLAND APPLICATIONS

VIRGINIA DEPARTMENT OF TRANSPORTATION

SPECIFICATION
REFERENCE

105
502

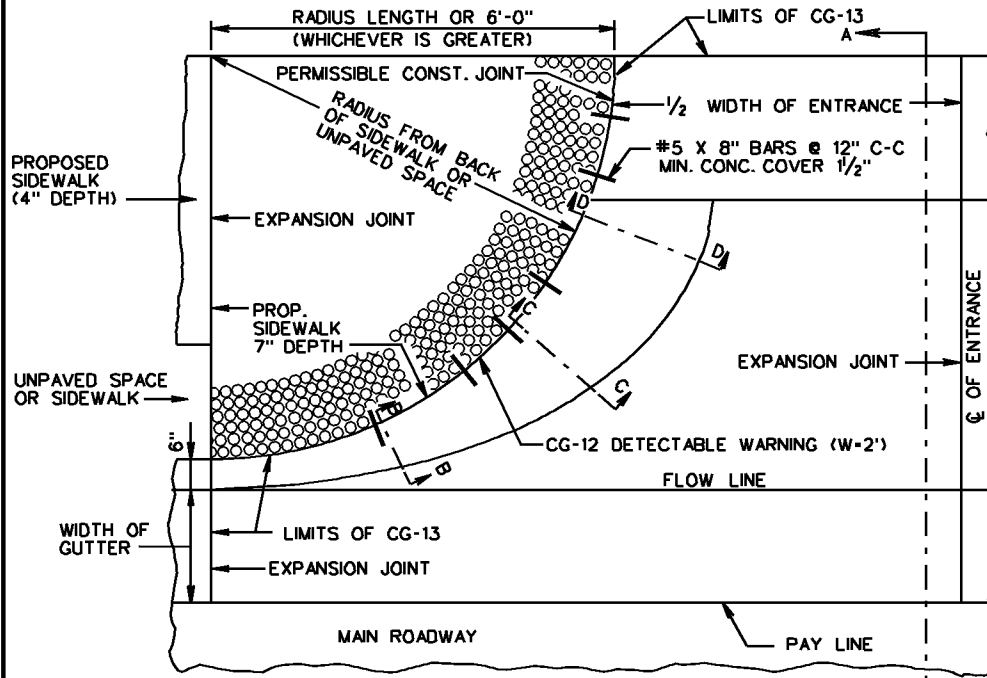

HALF PLAN

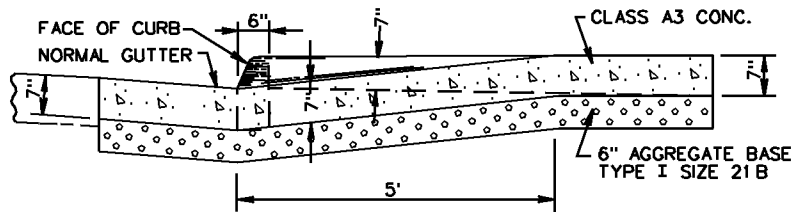

SECTION A-A

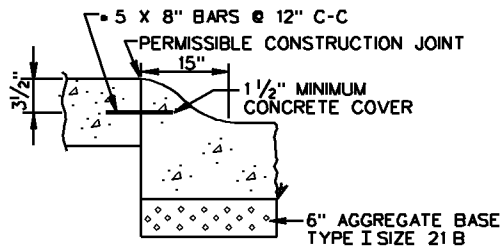

SECTION B-B

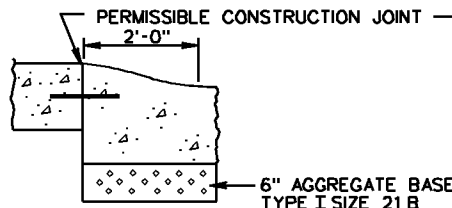

SECTION C-C

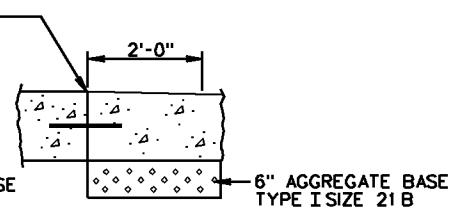

SECTION D-D

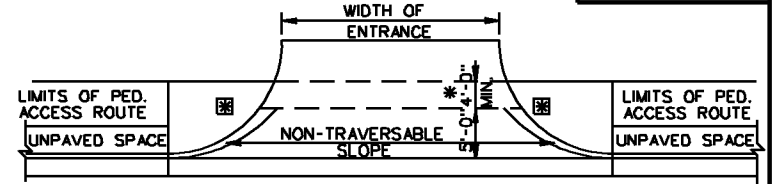

PEDESTRIAN ACCESS ROUTE DETAIL

ADDITIONAL RIGHT-OF-WAY IS REQUIRED IF THE LIMITS OF PEDESTRIAN ACCESS ROUTE EXTEND BEYOND EXISTING OR PROPOSED VDOT RIGHT-OF WAY.

PEDESTRIAN ACCESS ROUTES PROVIDE A CONTINUOUS UNOBSTRUCTED, STABLE, FIRM AND SLIP RESISTANT PATH CONNECTING ALL ACCESSIBLE ELEMENTS OF A FACILITY THAT CAN BE APPROACHED, ENTERED AND USED BY PEDESTRIANS. IF ACCESS ROUTE IS ADJACENT TO BACK OF CURB, MINIMUM WIDTH SHOULD BE 6'.

* IF PEDESTRIAN ACCESS ROUTES ARE BEING PROVIDED, A MINIMUM 4' TRAVERSABLE WIDTH IS REQUIRED WITH MAX. 2% CROSS SLOPE.

NOTES:

1. PROPOSED 7" SIDEWALK IS TO BE POURED MONOLITHICALLY WITH ENTRANCE OR BY USING PERMISSIBLE CONSTRUCTION JOINT WITH REQUIRED BARS.
2. PROPOSED 7" SIDEWALK TO BE CLASS A-3 CONCRETE.
3. REQUIRED BARS ARE TO BE NO. 5X8" PLACED 1' CENTER TO CENTER ALONG BACK OF CURB, MID-DEPTH OF SIDEWALK. MINIMUM CONCRETE COVER 1 1/2".
4. ALL DETAILS AND DIMENSIONS NOT SHOWN ARE THE SAME AS STANDARD CG-9D.
5. THIS DESIGN MAY ALSO BE APPLIED TO OTHER ENTRANCE STANDARDS AS THE NEED ARISES.
6. WHEN USED IN CONJUNCTION WITH STANDARD CG-3 OR CG-7, THE CURB FACE ON THIS STANDARD IS TO BE ADJUSTED TO MATCH THE MOUNTABLE CURB CONFIGURATION.
7. SEE STANDARD CG-12 FOR DETECTABLE WARNING DETAILS.

SPECIFICATION REFERENCE
502

COMMERCIAL ENTRANCE
(HEAVY TRUCK TRAFFIC ANTICIPATED)

VIRGINIA DEPARTMENT OF TRANSPORTATION

VDOT	
ROAD AND BRIDGE STANDARDS	
REVISION DATE	SHEET 1 OF 1
	203.09

THIS PAGE INTENTIONALLY LEFT BLANK



ROAD AND BRIDGE STANDARDS

SHEET 1 OF 1

REVISION DATE

SPECIFICATION
REFERENCE

VIRGINIA DEPARTMENT OF TRANSPORTATION

SECTION 300

PAVEMENT ITEMS

THIS PAGE INTENTIONALLY LEFT BLANK



ROAD AND BRIDGE STANDARDS

SHEET 1 OF 1

REVISION DATE

SPECIFICATION
REFERENCE

VIRGINIA DEPARTMENT OF TRANSPORTATION

STANDARD	TITLE	PAGE
PR-2	PLAIN AND REINFORCED CONCRETE PAVEMENT SHOWING REINFORCEMENT, LONGITUDINAL AND TRANSVERSE JOINTS	301.01
	PLAIN AND REINFORCED CONCRETE PAVEMENT SHOWING REINFORCEMENT, LONGITUDINAL AND TRANSVERSE JOINTS	301.02
	PLAIN AND REINFORCED CONCRETE PAVEMENT SHOWING REINFORCEMENT, LONGITUDINAL AND TRANSVERSE JOINTS	301.03
	STANDARD LOAD TRANSFER ASSEMBLY CONTRACTION JOINT	301.04
	STANDARD LOAD TRANSFER ASSEMBLY EXPANSION JOINT	301.05
PR-3	8" CONTINUOUSLY REINFORCED CONCRETE PAVEMENT (WIRE MESH REINFORCEMENT) THIS STANDARD IS VOID	301.06
	8" CONTINUOUSLY REINFORCED CONCRETE PAVEMENT (STEEL BAR REINFORCEMENT)	301.07
	8" CONTINUOUSLY REINFORCED CONCRETE PAVEMENT (FOR USE WITH BAR OR WIRE MESH REINFORCEMENT)	301.08
	8" CONTINUOUSLY REINFORCED CONCRETE PAVEMENT (LEAVE OUT JOINT DETAIL)	301.09
PR-4	9" CONTINUOUSLY REINFORCED CONCRETE PAVEMENT (STEEL BAR REINFORCEMENT)	301.10
	9" CONTINUOUSLY REINFORCED CONCRETE PAVEMENT (FOR USE WITH BAR REINFORCEMENT ONLY)	301.11
	9" CONTINUOUSLY REINFORCED CONCRETE PAVEMENT (LEAVE OUT JOINT DETAIL)	301.12
PR-5	9" CONTINUOUSLY REINFORCED CONCRETE PAVEMENT 14 FOOT TRAVEL LANE	301.13
	9" CONTINUOUSLY REINFORCED CONCRETE PAVEMENT 14 FOOT TRAVEL LANE	301.14
	9" CONTINUOUSLY REINFORCED CONCRETE PAVEMENT 14 FOOT TRAVEL LANE	301.15
PR-6	10" CONTINUOUSLY REINFORCED CONCRETE PAVEMENT 14 FOOT TRAVEL LANE	301.16
	10" CONTINUOUSLY REINFORCED CONCRETE PAVEMENT 14 FOOT TRAVEL LANE	301.17
	10" CONTINUOUSLY REINFORCED CONCRETE PAVEMENT 14 FOOT TRAVEL LANE	301.18
PR-7	11" CONTINUOUSLY REINFORCED CONCRETE PAVEMENT 14 FOOT TRAVEL LANE	301.19
	11" CONTINUOUSLY REINFORCED CONCRETE PAVEMENT 14 FOOT TRAVEL LANE	301.20
	11" CONTINUOUSLY REINFORCED CONCRETE PAVEMENT 14 FOOT TRAVEL LANE	301.21
PR-8	12" CONTINUOUSLY REINFORCED CONCRETE PAVEMENT 14 FOOT TRAVEL LANE	301.22
	12" CONTINUOUSLY REINFORCED CONCRETE PAVEMENT 14 FOOT TRAVEL LANE	301.23
	12" CONTINUOUSLY REINFORCED CONCRETE PAVEMENT 14 FOOT TRAVEL LANE	301.24
PR-9	13" CONTINUOUSLY REINFORCED CONCRETE PAVEMENT 14 FOOT TRAVEL LANE	301.25
	13" CONTINUOUSLY REINFORCED CONCRETE PAVEMENT 14 FOOT TRAVEL LANE	301.26
	13" CONTINUOUSLY REINFORCED CONCRETE PAVEMENT 14 FOOT TRAVEL LANE	301.27
XJ-1	BRIDGE APPROACH EXPANSION JOINT (FOR WIDENING OR MAINTENANCE OF EXISTING XJ-1 ONLY)	302.01
	BRIDGE APPROACH EXPANSION JOINT (INSTALLATION CRITERIA)	302.02
WP-1	METHOD OF WIDENING BRIDGE APPROACH PAVEMENT THIS STANDARD IS VOID	303.01
WP-2	PAVEMENT WIDENING	303.02
RS-1	CONTINUOUS SHOULDER RUMBLE STRIPS	304.01
RS-3	CENTERLINE RUMBLE STRIPS	304.02
RS-4	CONTINUOUS SHOULDER RUMBLE STRIPES	304.03
RS-5	INTERMITTENT SHOULDER RUMBLE STRIPS	304.04
ACOT-1	ASPHALT CONCRETE OVERLAY TRANSITIONS (REPLACES THE STANDARD TPT-1 TRANSVERSE PAVEMENT TIE-IN)	305.01

INDEX OF SHEETS
SECTION 300-PAVEMENT ITEMS

VIRGINIA DEPARTMENT OF TRANSPORTATION



ROAD AND BRIDGE STANDARDS

REVISION DATE

SHEET 1 OF 1

7/13

300.01

THIS PAGE INTENTIONALLY LEFT BLANK



ROAD AND BRIDGE STANDARDS

SHEET 1 OF 1

REVISION DATE

300.02

VIRGINIA DEPARTMENT OF TRANSPORTATION

SPECIFICATION
REFERENCE

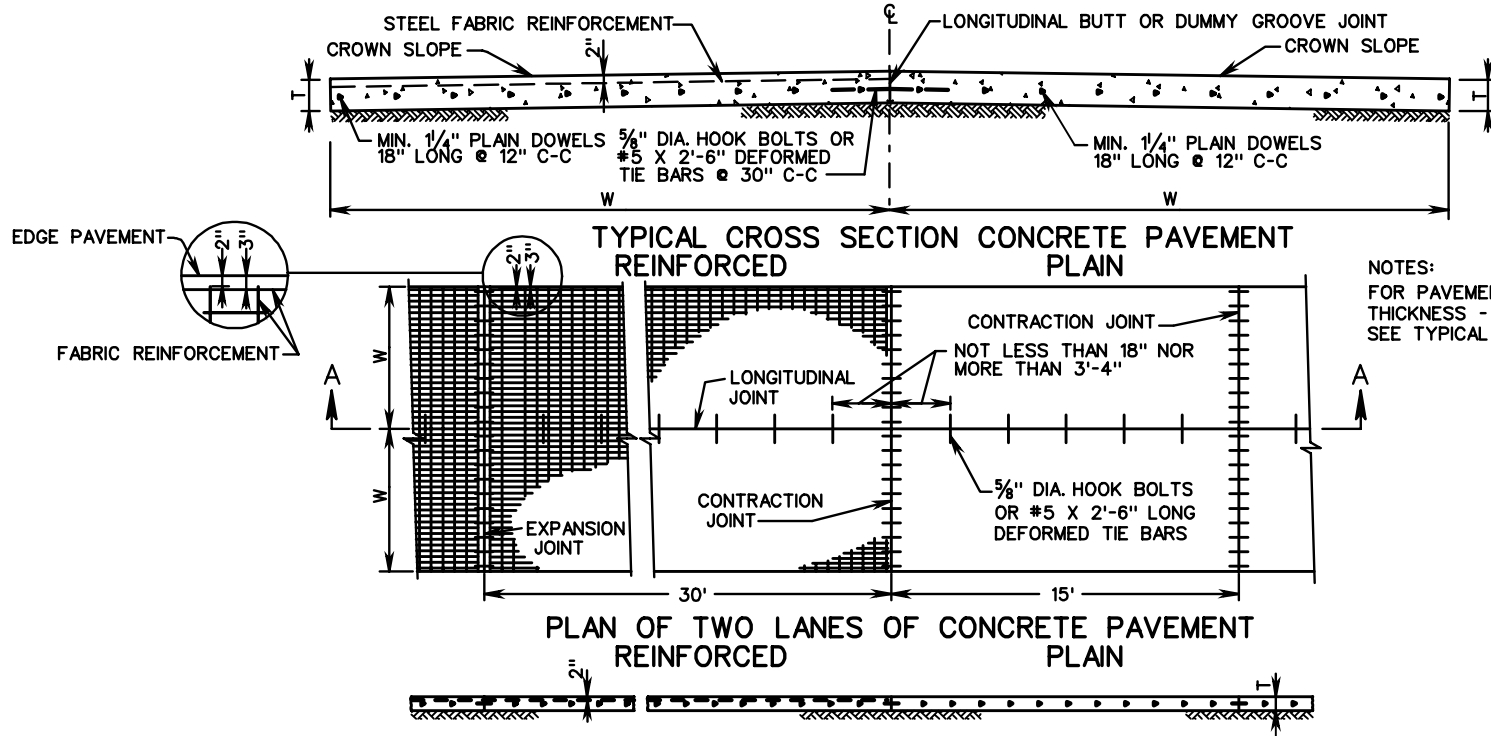

NOTES:
FOR PAVEMENT CROWN SLOPE,
THICKNESS - "T", LANE WIDTH - "W",
SEE TYPICAL SECTIONS IN PLANS.

STEEL FABRIC REINFORCEMENT: STEEL FABRIC REINFORCEMENT SHALL CONSIST OF MEMBERS RIGIDLY ATTACHED AT ALL JOINTS OR POINTS OF INTERSECTION EXCEPT AS NOTED BELOW:(*). LONGITUDINAL MEMBERS SHALL BE OF NO. 2 GAGE WIRE SPACED AT 6" ON CENTERS. TRAVERSE MEMBERS SHALL BE NO. 4 GAGE WIRE, SPACED AT 12" ON CENTERS. (WIRE REINFORCEMENT STEEL INSTITUTE DESIGNATION 6 X 12 - W5.5 X W4).

THE WIDTHS OF STEEL FABRIC SHEETS SHALL BE 4" LESS THAN THE WIDTH OF THE SLAB. THE NUMBER OF SHEETS ALLOWABLE BETWEEN CONTRACTION JOINTS, OR BETWEEN CONTRACTION AND EXPANSION JOINTS, SHALL NOT EXCEED 3.

ALL MEMBERS, LONGITUDINAL OR TRANSVERSE, SHALL BE SO CUT THAT THE PROJECTING ENDS WILL EXTEND NOT LESS THAN 1" NOR MORE THAN 11" FROM THE JOINTS OR POINTS OF INTERSECTION OF THE FABRIC MEMBERS.

WHEN IT IS NECESSARY TO LAP STEEL FABRIC REINFORCEMENT, THE MINIMUM AMOUNT OF LAP SHALL BE EQUIVALENT TO THE SPACING OF THE WIRES PARALLEL TO THE LAP.

OTHER TYPES OF MESH REINFORCEMENT MAY BE USED ON WRITTEN PERMISSION OF THE ENGINEER. THE WIDTH OF SHEETS AND OTHER GENERAL REQUIREMENTS, WHICH APPLY, SHALL BE THE SAME AS FOR STEEL FABRIC REINFORCEMENT.

DOWELS AT CONTRACTION JOINTS MAY BE PLACED IN THE FULL THICKNESS OF PAVEMENT BY MECHANICAL DEVICE IN LIEU OF DOWEL BASKETS.

* HINGED STEEL REINFORCEMENT MAY BE USED IN LIEU OF RIGID SHEETS.

EXPANSION AND CONTRACTION JOINTS: CONSTRUCTION JOINTS IN BOTH PLAIN AND REINFORCED PAVEMENT SHALL HAVE THE SAME LOAD TRANSFER DEVICES AS NOTED FOR CONTRACTION JOINTS IN REINFORCED PAVEMENT.

CONTRACTION JOINTS OF THE TYPE SPECIFIED ON SHEET 2 SHALL BE SPACED AT 30 FOOT INTERVALS FOR REINFORCED CONCRETE PAVEMENT AND AT 15 FOOT INTERVALS FOR PLAIN CONCRETE PAVEMENT UNLESS OTHERWISE NOTED ON JOINT LAYOUTS IN PLANS.

ADJACENT TO RIGID STRUCTURES: CONCRETE STREET INTERSECTIONS, OR R.R. GRADE X-INGS, BRIDGE APPROACH EXPANSION JOINTS AND/OR TRANSVERSE EXPANSION JOINTS ARE TO BE PLACED AS SHOWN ON SHEET 2 OF 3. OTHER EXPANSION JOINTS ARE TO BE USED AS SPECIFIED ON PLANS.

IF ASPHALT CONCRETE IS TO BE APPLIED, ALL TRANSVERSE JOINTS ARE TO BE SAWED, BUT NOT WIDENED, EXCEPT AT THE END OF A DAYS RUN AND WHEN INTERRUPTIONS OCCUR IN THE CONCRETE OPERATIONS OF MORE THAN 30 MINUTES DURATION. IN THESE CASES, BUTT CONSTRUCTION JOINTS ARE TO BE USED.

PAVED SHOULDERS: WHEN ASPHALT CONCRETE PAVED SHOULDERS ARE TO BE USED ADJACENT TO EITHER PLAIN OR REINFORCED CEMENT CONCRETE PAVEMENT, THE EDGE OF THE CONCRETE SLAB IS TO BE PAINTED, TO ITS FULL DEPTH, WITH ASPHALTIC MATERIAL EITHER CRS-2 OR RC-250 AS DIRECTED BY THE ENGINEER.

LONGITUDINAL JOINTS: THE CONTRACTOR WILL BE PERMITTED TO CONSTRUCT THE CONCRETE PAVEMENT IN DUAL LANES, SIMULTANEOUSLY, WHERE THE SUM OF THE LANE WIDTHS DOES NOT EXCEED 25 FEET, PROVIDED A SATISFACTORY AND TRUE LONGITUDINAL DUMMY GROOVE JOINT IS OBTAINED. THIS IS TO BE DONE BY THE USE OF AN APPROVED FORMING STRIP OR BY SAWING, AT THE CONTRACTOR'S OPTION. WHERE LANES ARE POURED SEPARATELY, THE HOOK BOLTS OR TIE BOLTS SHALL BE IN ACCORDANCE WITH THE DETAILS SHOWN OF SHEET 2. WHERE BOTH LANES ARE POURED SIMULTANEOUSLY, TIE BARS SHALL BE AS DETAILED ON SHEET 2. THE MAXIMUM WIDTH OF PAVEMENT THAT MAY BE CONSTRUCTED WITHOUT A LONGITUDINAL JOINT IS 14'-0". FOR WIDTHS GREATER THAN 14 FEET THE LONGITUDINAL JOINT SHALL BE IN THE CENTER. NO OTHER DEVIATIONS ARE TO BE ALLOWED UNLESS SHOWN ON JOINT LAYOUT IN PLANS, OR DIRECTED BY THE ENGINEER.

METHOD OF FINISHING AT EXPANSION JOINTS: A PROTECTIVE CAP OR INSTALLATION SHIELD OF 1/16" STEEL SHALL BE PLACED OVER THE TOP OF THE EXPANSION JOINT FILLER. THE FINISHING MACHINE SHALL THEN BE ALLOWED TO PASS OVER THE JOINT, LEAVING IT AS SHOWN IN FIGURE 1, SHEET 2. PRIOR TO THE INITIAL SET THE SHIELD SHALL BE REMOVED AND A RECTANGULAR BAR 1/4" LESS IN WIDTH THAN THE PREFORMED FILLER PLACED ON TOP OF THE FILLER, THE CONCRETE SQUEEGE FINISHED ADJACENT TO IT AS SHOWN IN FIGURE 2, AND THE EDGES ROUNDED WITH HAND TOOLS, USING THE BAR AS A GUIDE. THE BAR SHALL THEN BE WITHDRAWN, LEAVING A JOINT GAP OF THE SAME WIDTH AS THE FILLER.

SPECIFICATION REFERENCE

316

PLAIN AND REINFORCED CONCRETE PAVEMENT (SHOWING REINFORCEMENT, LONGITUDINAL AND TRANSVERSE JOINTS)

VIRGINIA DEPARTMENT OF TRANSPORTATION

VDOT

ROAD AND BRIDGE STANDARDS

REVISION DATE

SHEET 1 OF 5

301.01

PR-2

FOR X AND Y DIM. SEE
ST'D. PR-2 SHEET 3 OF 5

⊗ JT. SEALANTS TO BE IN
ACCORDANCE WITH
DETAILS ON ST'D. PR-2
SHEET 3 OF 5

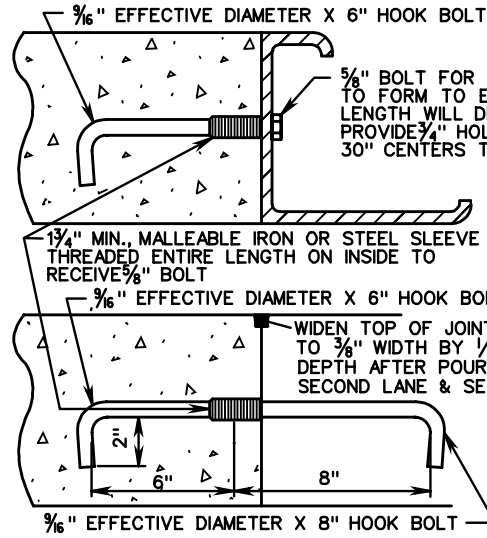
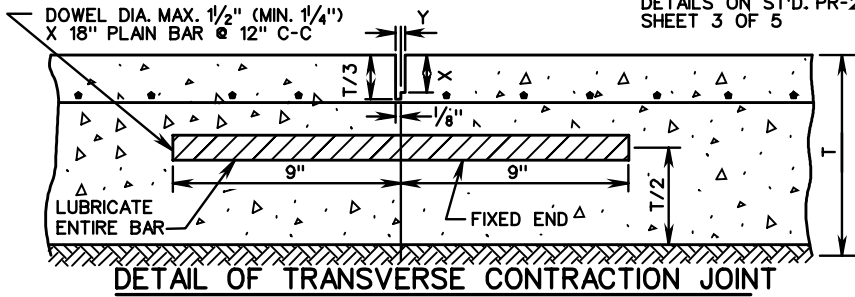

NOTE:
3/8" EFFECTIVE DIAMETER HOOK BOLTS TO BE 3/8" DIAMETER STOCK FOR ROLLED THREADS AND 5/8" DIAMETER STOCK FOR CUT THREADS O.D. OF THREADED PORTION TO BE 5/8".
ANY SIMILAR DEVICE OF EQUAL STRENGTH WILL BE ACCEPTED IF APPROVED BY THE ENGINEER.
NOTE:
#5 X 2'-6" DEFORMED TIE BARS AT 30" C-C MAY BE USED IN LIEU OF HOOK BOLTS.

⊗ SEAL WITH AN APPROVED JOINT SEALANT. A BAND BREAKING MATERIAL IS TO BE PROVIDED BETWEEN THE JOINT FILLER AND SEAL.

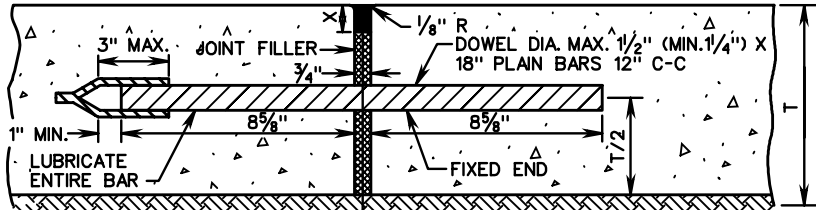

DETAIL OF TRANSVERSE EXPANSION JOINT
FOR X AND Y DIMENSIONS SEE STANDARD PR-2 SHEET 3 OF 5.

WIDEN TOP OF GROOVE TO 3/8" WIDTH BY 1/2" DEPTH & SEAL IF ASPHALT TOP NOT USED.

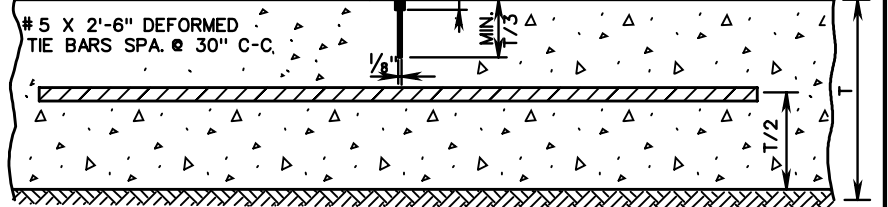

DETAIL OF LONGITUDINAL JOINT TIE BARS
SHOWING ADJACENT LANES POURED SIMULTANEOUSLY

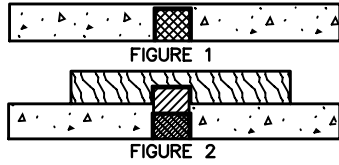

SMOOTH SURFACE TO BE STEEL TROWELED 8" IN FROM THE EDGE OF PAVEMENT EVERY 500', AND STATION NUMBER STAMPED INTO IT. THE DATE IS TO BE SHOWN IN A SIMILAR MANNER AT THE BEGINNING OF EACH DAY'S POUR.
BOTH OUTSIDE EDGES OF DIVIDED HIGHWAY TO BE STAMPED. ONE EDGE OF UNDIVIDED HIGHWAYS WHERE FEASIBLE.

METHOD OF FINISHING AT EXPANSION JOINTS

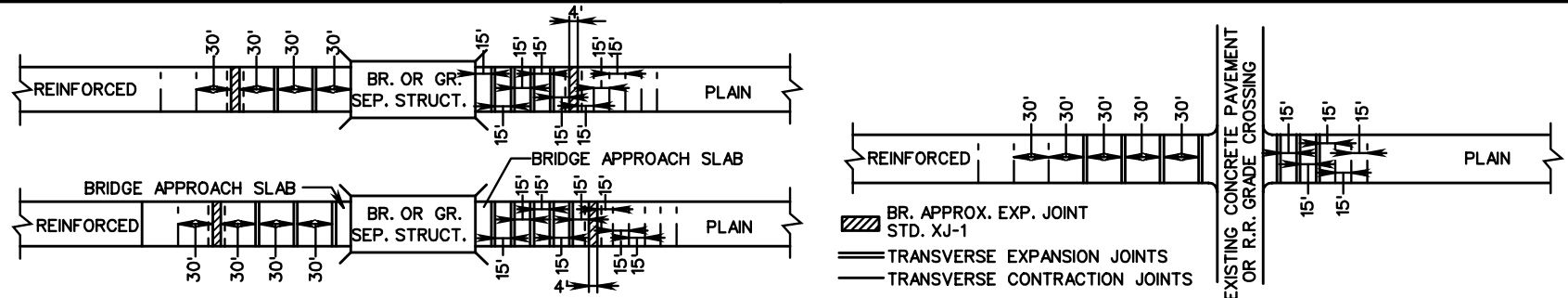

DETAILS OF JOINTS LAYOUTS
(FOR USE WHEN COVERED ON JOINT LAYOUTS IN PLANS)



ROAD AND BRIDGE STANDARDS

PLAIN AND REINFORCED CONCRETE PAVEMENT
(SHOWING REINFORCEMENT, LONGITUDINAL AND TRANSVERSE JOINTS)

SPECIFICATION REFERENCE

SHEET 2 OF 5

REVISION DATE

VIRGINIA DEPARTMENT OF TRANSPORTATION

316

301.02

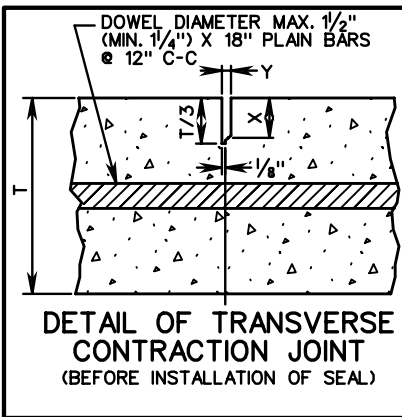

DETAIL OF TRANSVERSE CONTRACTION JOINT
(BEFORE INSTALLATION OF SEAL)

GENERAL NOTES

ALTERNATE PREFORMED SEALANTS HAVING A CROSS-SECTIONAL AREA COMPARABLE TO TYPE A (CONTRACTION JOINTS) AND TYPE D (EXPANSION JOINTS) AND MEETING THE APPROVAL OF THE ENGINEER MAY BE SUBSTITUTED.

OTHER TYPES OF JOINT MATERIAL ARE TO BE IN ACCORDANCE WITH THE SPECIFICATIONS.

ALL DETAILS NOT SHOWN HEREON TO BE IN ACCORDANCE WITH STANDARDS PR-2, SHEET 2 OF 5.

ALL CONTRACTION JOINTS TO BE SAWED IN CONFORMANCE WITH DETAIL TO THE LEFT, EXCEPT THAT WHERE GRAVEL AGGREGATE IS USED IN THE CONCRETE, THE JOINT MAY BE PREPARED BY FORMING 1/4" OR LESS OF THE WIDTH, FOR THE DEPTH SHOWN WITH NON-METALLIC OR REMOVABLE MATERIAL, FOLLOWED BY SAWING TO COMPLETE THE JOINT TO THE REQUIRED WIDTH AND DEPTH.

FOR DETAILS OF TRANSVERSE CONSTRUCTION JOINT, SEE BELOW.

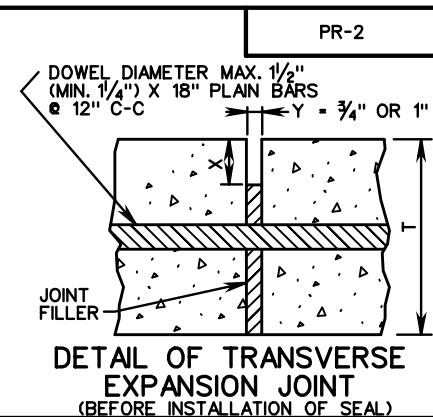

DETAIL OF TRANSVERSE EXPANSION JOINT
(BEFORE INSTALLATION OF SEAL)

PREFORMED CHLOROPRENE ELASTOMERIC JOINT SEALANT

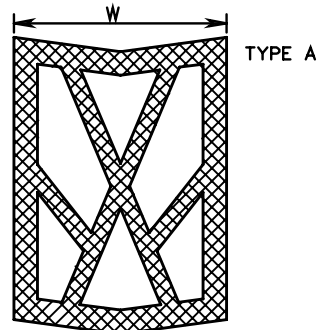

SEALANTS FOR TRANSVERSE CONTRACTION JOINTS

SILICONE JOINT SEALANT

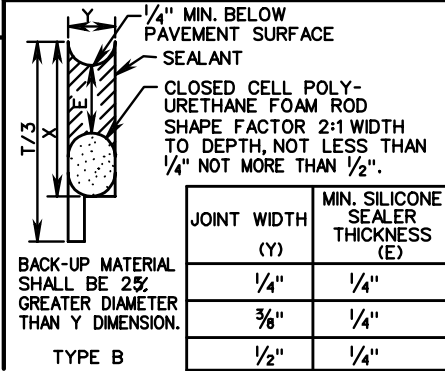

JOINT WIDTH (Y)	MIN. SILICONE SEALER THICKNESS (E)
1/4"	1/4"
3/8"	1/4"
1/2"	1/4"

SILICONE JOINT SEALANT

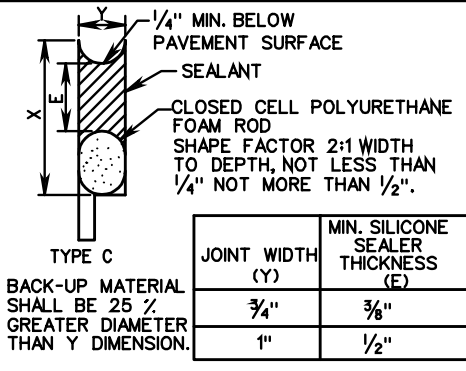

JOINT WIDTH (Y)	MIN. SILICONE SEALER THICKNESS (E)
3/4"	3/8"
1"	1/2"

SEALANTS FOR TRANSVERSE EXPANSION JOINTS

PREFORMED CHLOROPRENE ELASTOMERIC JOINT SEALANT

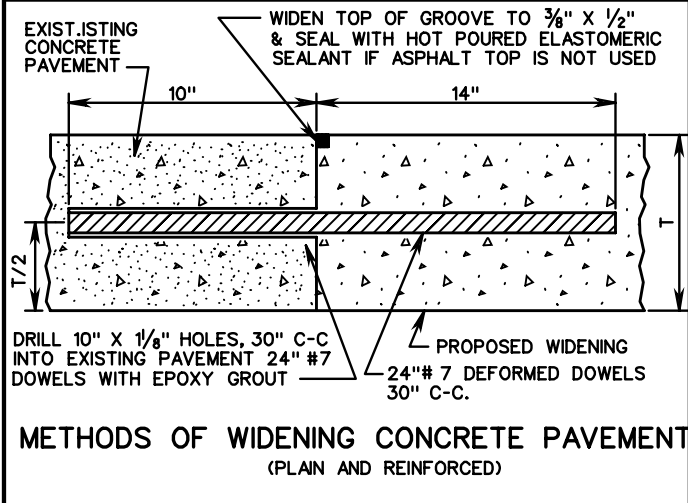
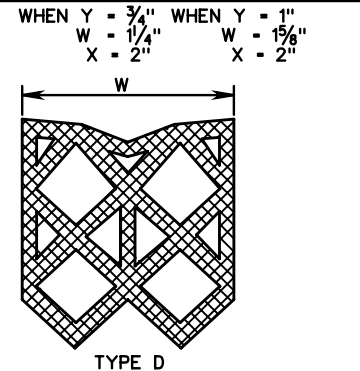

METHODS OF WIDENING CONCRETE PAVEMENT
(PLAIN AND REINFORCED)

DIMENSION	SEALANT TYPE			
	A	B	C	D
X	1 3/4"	1/4"	1 3/4" - 2"	2"
Y	1/4"	1/4"	3/4" OR 1"	3/4" OR 1"
W	5/8" ± 1/16"	-	-	-

DIMENSION	SEALANT TYPE			
	A	B	C	D
X	1 3/4"	1/4"	1 3/4" OR 2"	2"
Y	3/8"	3/8"	3/4" OR 1"	3/4" OR 1"
W	1/4" ± 1/16"	-	-	-

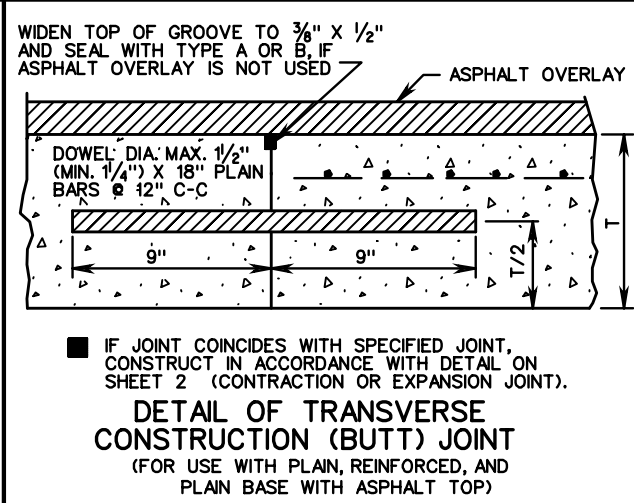

IF JOINT COINCIDES WITH SPECIFIED JOINT, CONSTRUCT IN ACCORDANCE WITH DETAIL ON SHEET 2 (CONTRACTION OR EXPANSION JOINT).

DETAIL OF TRANSVERSE CONSTRUCTION (BUTT) JOINT
(FOR USE WITH PLAIN, REINFORCED, AND PLAIN BASE WITH ASPHALT TOP)

SPECIFICATION REFERENCE
316

PLAIN AND REINFORCED CONCRETE PAVEMENT
SHOWING REINFORCEMENT, LONGITUDINAL AND TRANSVERSE JOINTS

VIRGINIA DEPARTMENT OF TRANSPORTATION

VDOT	
ROAD AND BRIDGE STANDARDS	
REVISION DATE	SHEET 3 OF 5
301.03	

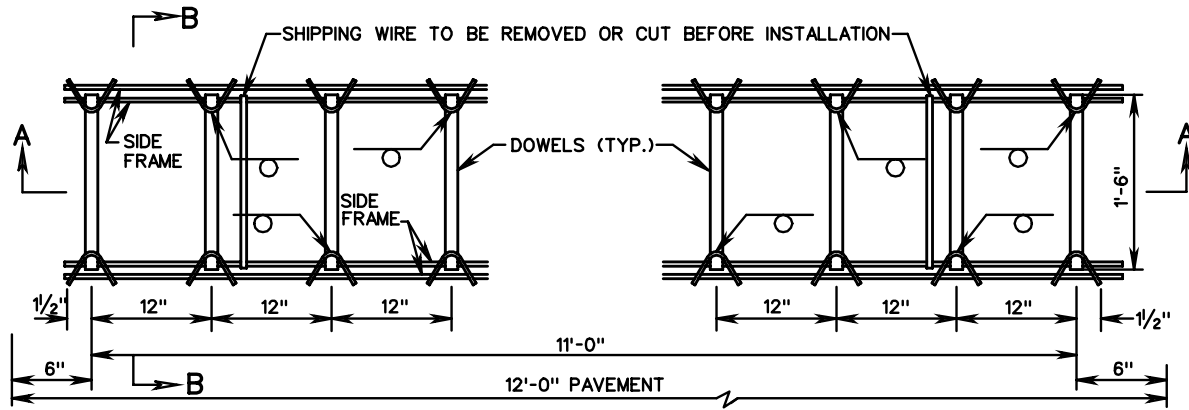

PLAN OF DOWEL UNIT FOR CONTRACTION JOINT

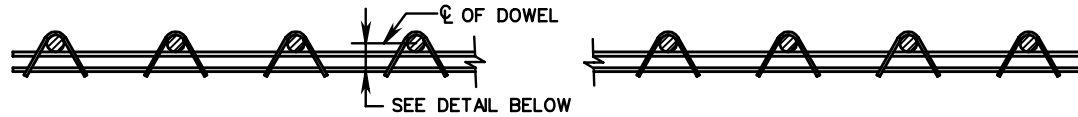

SIDE ELEVATION A - A CONTRACTION JOINT

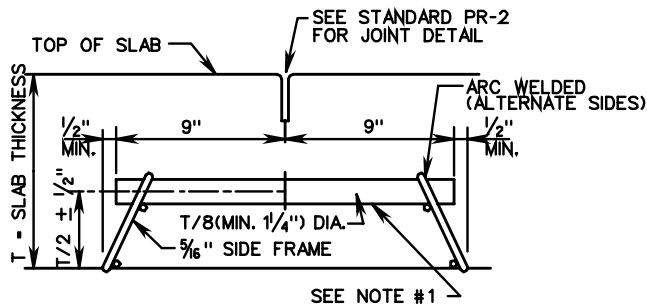

SECTION B - B
THRU CONTRACTION JOINT

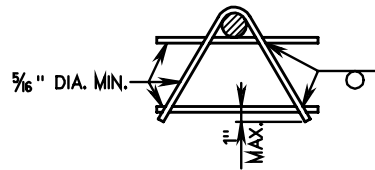

SIDE FRAME DETAIL

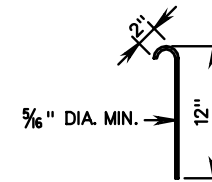

STAKING PIN

NOTES:

1. ENTIRE BAR TO BE LUBRICATED.
2. STAKING PINS, A MINIMUM SIX PER ASSEMBLY, THREE TO EACH SIDE.
3. EXPANSION AND CONTRACTION JOINTS: THE DEVICE FOR SUPPORTING DOWELS AT EXPANSION AND CONTRACTION JOINTS SHALL BE SO CONSTRUCTED THAT IT WILL HOLD THE DOWELS FIRMLY IN POSITION, PARALLEL TO THE SURFACE AND CENTERLINE OF THE SLAB.
4. NO MEMBERS SHALL BE PLACED SO THAT THEY WILL INTERFERE WITH THE FREE FLOW OF CONCRETE BETWEEN THE DOWELS.
5. ASSEMBLY AND WELDING OF ALL MEMBERS SHALL BE SUCH AS TO INSURE A GOOD WORKMANLIKE JOB, WITH ALL JOINTS TRUE AND SQUARE.
6. ASSEMBLIES WHICH HAVE BECOME WARPED OR DAMAGED IN TRANSIT OR STORAGE SO THEY WILL NOT CONFORM TO THE SUBGRADE SHALL NOT BE USED.
7. A SAMPLE OF THE SUPPORTING DEVICE SHALL BE SUBMITTED FOR APPROVAL PRIOR TO THE FILLING OF JOB ORDERS.

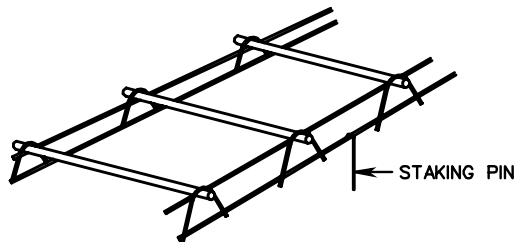

PERSPECTIVE VIEW



ROAD AND BRIDGE STANDARDS

SHEET 4 OF 5

REVISION DATE

301.04

STANDARD LOAD TRANSFER ASSEMBLY
CONTRACTION JOINT

VIRGINIA DEPARTMENT OF TRANSPORTATION

SPECIFICATION
REFERENCE

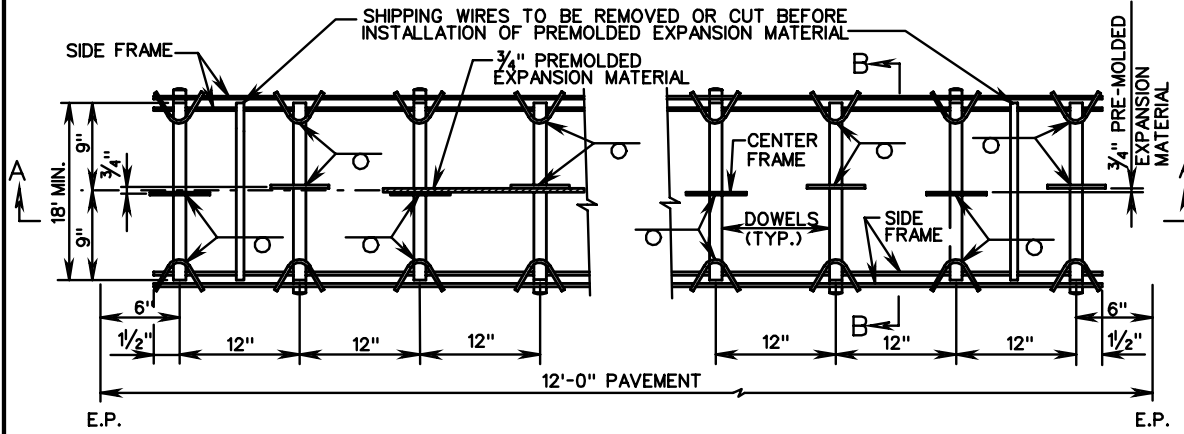

PLAN OF EXPANSION LIMIT

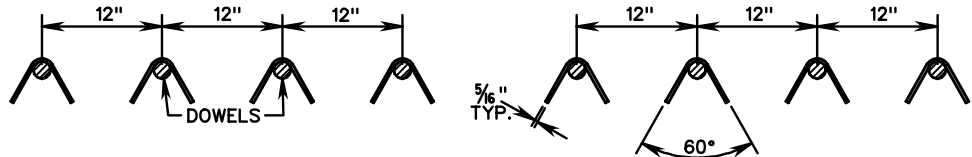
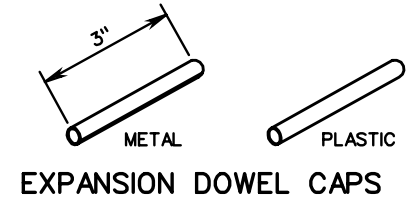
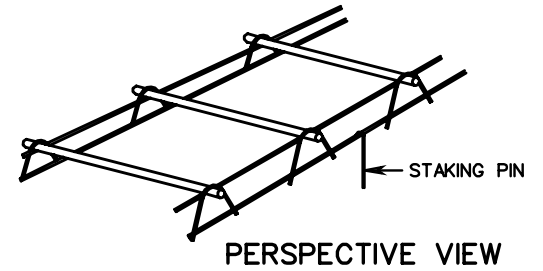

SECTION A - A CENTER FRAME

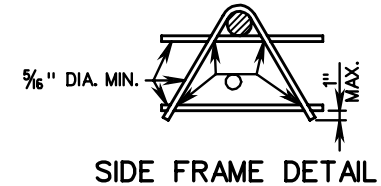

SIDE FRAME DETAIL

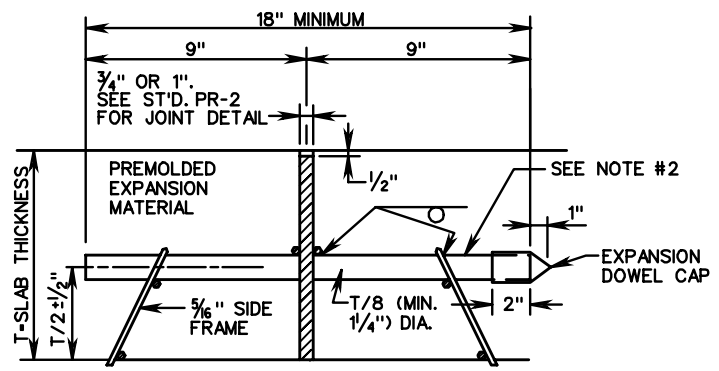

SECTION B - B THRU EXPANSION JOINT

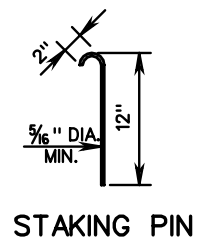

STAKING PIN

NOTES:

1. DOWEL BAR TO BE MIN. LENGTH OF 18". IF BAR IS NOT CENTERED THE LONG SIDE SHALL BE THE FREE END. SEE STANDARD PR-2.
2. ENTIRE BAR TO BE LUBRICATED.
3. STAKING PINS, A MINIMUM SIX PER ASSEMBLY, THREE TO EACH SIDE.
4. EXPANSION AND CONTRACTION JOINTS: THE DEVICE FOR SUPPORTING DOWELS AT EXPANSION AND CONTRACTION JOINTS SHALL BE SO CONSTRUCTED THAT IT WILL HOLD THE DOWELS FIRMLY IN POSITION, PARALLEL TO THE SURFACE AND CENTER-LINE OF THE SLAB.
5. NO MEMBERS SHALL BE PLACED SO THAT THEY WILL INTERFERE WITH THE FREE FLOW OF CONCRETE BETWEEN DOWELS.
6. ASSEMBLY AND WELDING OF ALL MEMBERS SHALL BE SUCH AS TO INSURE A GOOD WORKMANLIKE JOB, WITH ALL JOINTS TRUE AND SQUARE.
7. ASSEMBLIES WHICH HAVE BECOME WARPED OR DAMAGED IN TRANSIT OR STORAGE SO THEY WILL NOT CONFORM TO THE SUBGRADE SHALL NOT BE USED.
8. A SAMPLE OF THE SUPPORTING DEVICE SHALL BE SUBMITTED FOR APPROVAL PRIOR TO THE FILLING OF JOB ORDERS.

SPECIFICATION REFERENCE

STANDARD LOAD TRANSFER ASSEMBLY EXPANSION JOINT

VIRGINIA DEPARTMENT OF TRANSPORTATION

VDOT	
ROAD AND BRIDGE STANDARDS	
REVISION DATE	SHEET 5 OF 5
301.05	

PR-3

TRANSVERSE CONSTR. JOINT

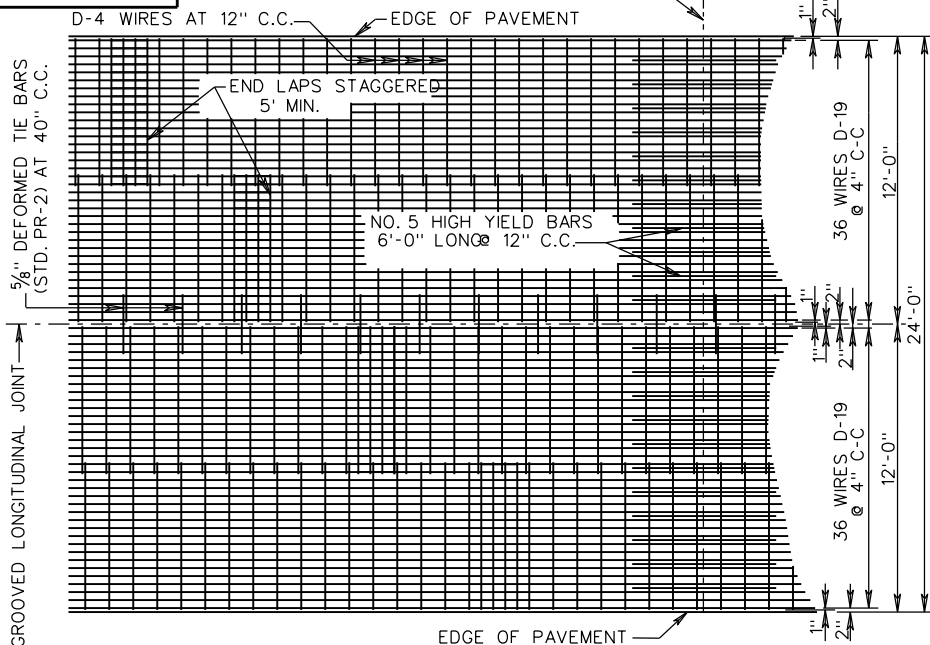

PLAN VIEW

HOOK BOLTS AT 30" C.C. TO BE USED WHEN PAVEMENT IS POURED IN SINGLE LANES.

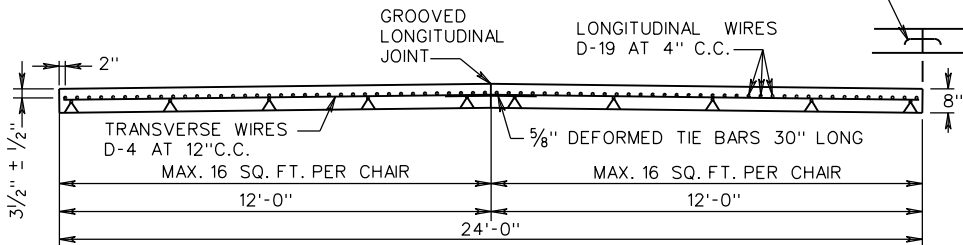

TRANSVERSE SECTION

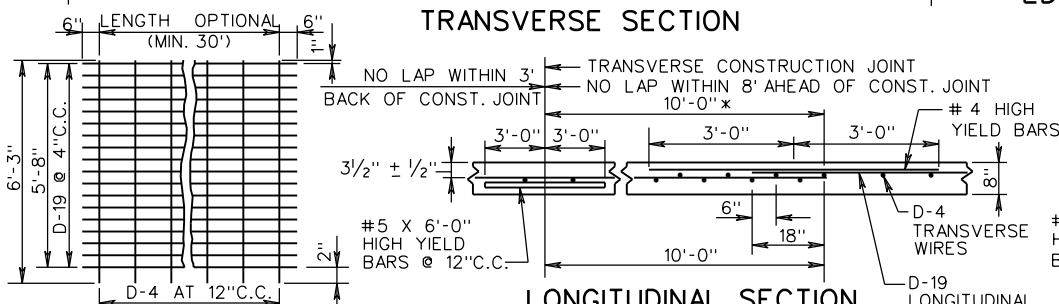

LONGITUDINAL SECTION

EDGE LAP DETAIL

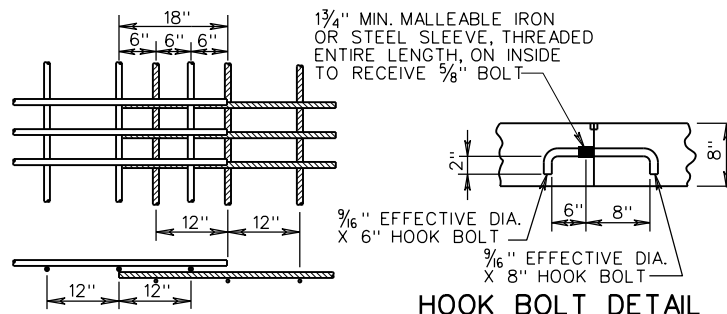

HOOK BOLT DETAIL

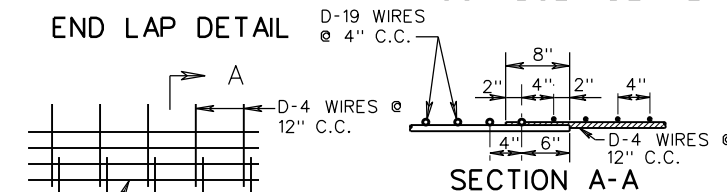

EDGE LAP DETAIL

SHEETS TO BE SECURELY FASTENED TO PREVENT SEPARATION DURING CONCRETE PLACEMENT.

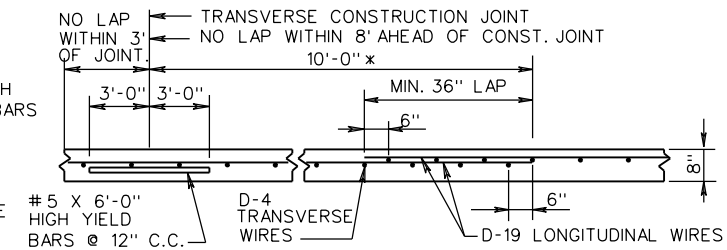

LONGITUDINAL SECTION

NOTES:

- FOR 36' PAVEMENT, USE SINGLE 12' LANES WITH 2 CONSTRUCTION JOINTS, OR 12' AND 24' LANES WITH ONE GROOVE AND ONE CONSTRUCTION JOINT.
- TRANSVERSE WIRES DO NOT EXTEND THROUGH LONGITUDINAL JOINTS.
- TIE BARS AND DOWEL BARS ARE TO BE AS NEAR MIDPOINT OF PAVEMENT DEPTH AS FEASIBLE.
- * THE DOUBLE LAP REQUIREMENT (36") AND OR EXTRA BAR METHOD APPLIES ONLY TO LAPS FALLING WITHIN AAN AREA 10' BEYOND THE CONSTRUCTION JOINT.
- #5 X 2'-6" DEFORMED TIE BARS AT 30" O.C. MAY BE USED IN LIEU OF HOOK BOLTS WHERE SHOWN HEREON.

SMOOTH SURFACE TO BE STEEL TROWELED 8" IN FROM THE EDGE OF PAVEMENT EVERY 500 FEET, AND STATION NUMBER STAMPED INTO IT. THE DATE IS TO BE SHOWN IN A SIMILAR MANNER AT THE BEGINNING OF EACH DAYS POUR.

BOTH OUTSIDE EDGES OF DIVIDED HIGHWAY TO BE STAMPED. ONE EDGE OF UNDIVIDED HIGHWAYS WHERE FEASIBLE. (TRAVEL LANE)

SHEETS TO BE SECURELY FASTENED TO PREVENT SEPARATION DURING CONCRETE PLACEMENT.

TYPICAL WIRE FABRIC SHEET WAS EXTRA BAR METHOD THE JULY 2011 ROAD REVISION DOUBLE LAP METHOD REVISION

8" THICK CONTINUOUSLY REINFORCED CONC. PAVE.

(WIRE MESH REINFORCEMENT)

VIRGINIA DEPARTMENT OF TRANSPORTATION

SPECIFICATION REFERENCE

316



ROAD AND BRIDGE STANDARDS

SHEET 1 OF 4

REVISION DATE

301.06

NOTES: HOOK BOLTS OR TIE BARS ARE TO BE PLACED IN THE SAME HORIZONTAL PLANE AS # 4 TRANSVERSE BARS. WHERE NECESSARY ADJUST THE LOCATION OF HOOK BOLTS OR TIE BARS TO A 2 1/2" MINIMUM CLEARANCE BETWEEN HOOK BOLTS OR TIE BARS AND TRANSVERSE BARS.

TRANSVERSE CONSTRUCTION JOINT BARS ARE TO BE PLACED IN THE SAME HORIZONTAL AS # 5 LONGITUDINAL BARS.

#5 LONGITUDINAL BARS ARE TO BE LAPPED AND TIED IN THE SAME HORIZONTAL PLANE.

FOR 36' WIDTH PAVEMENT USE SINGLE 12' LANES WITH 2 LONGITUDINAL CONSTRUCTION JOINTS OR 12' AND 24' LANES WITH ONE LONGITUDINAL CONSTRUCTION JOINT AND ONE GROVED LONGITUDINAL JOINT. TRANSVERSE BARS SHALL NOT EXTEND THROUGH LONGITUDINAL CONSTRUCTION JOINTS, BUT SHALL EXTEND FULL LENGTH (23'-9") FOR GROOVED LONGITUDINAL JOINTS.

SMOOTH SURFACE TO BE STEEL TROWELED 8" IN FROM THE EDGE OF PAVEMENT EVERY 500 FEET, AND STATION NUMBER STAMPED INTO IT.

THE DATE IS TO BE SHOWN IN A SIMILIAR MANNER AT THE BEGINNING OF EACH DAYS POUR.

BOTH OUTSIDE EDGES OF DIVIDED HIGHWAY TO BE STAMPED. ONE EDGE OF UNDIVIDED HIGHWAYS WHERE FEASIBLE.(TRAVEL LANE)

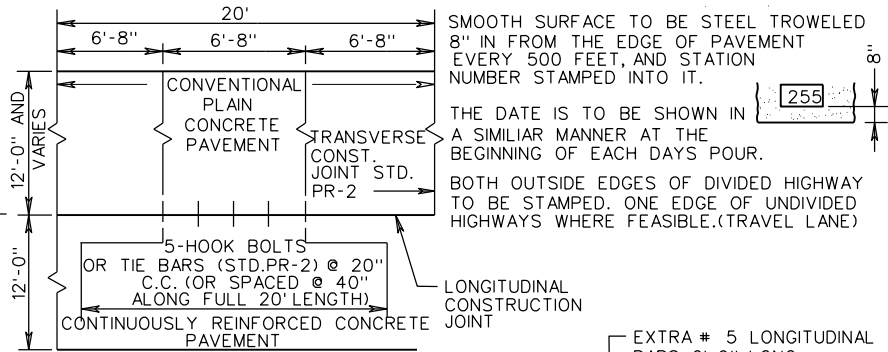
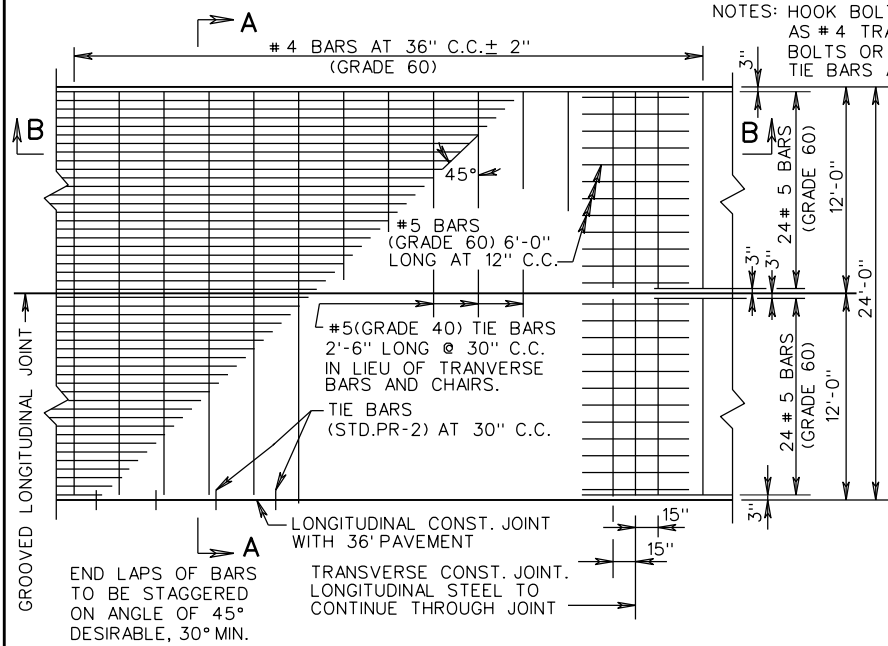

END LAPS OF BARS TO BE STAGGERED ON ANGLE OF 45° DESIRABLE, 30° MIN.

PLAN-RAMP & MAIN LINE CONNECTION

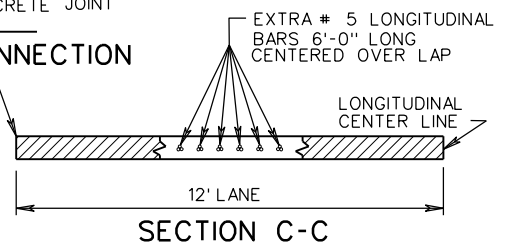
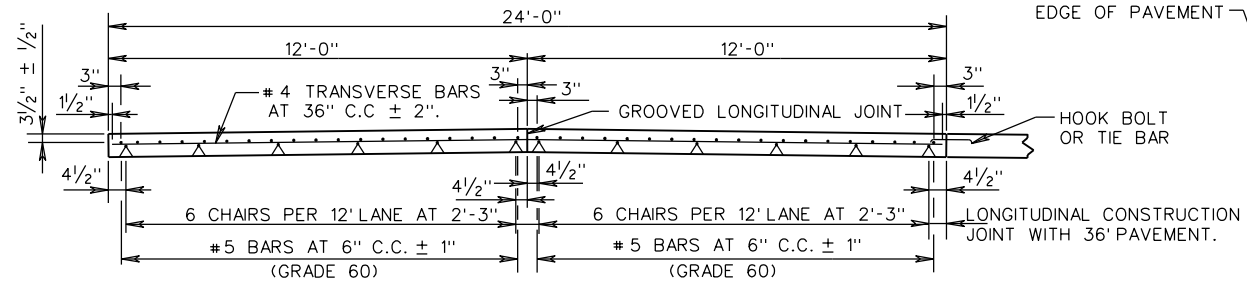

SECTION C-C

SECTION A-A

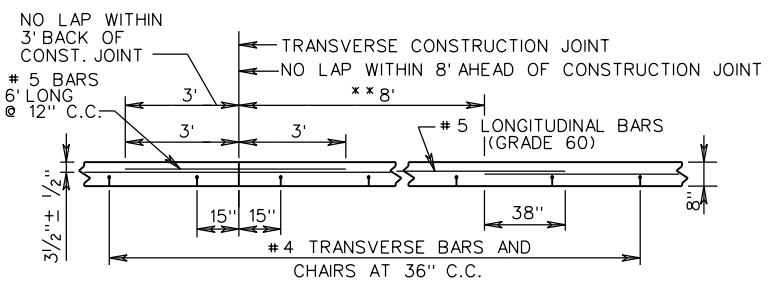

**SECTION B-B
DOUBLE LAP METHOD**

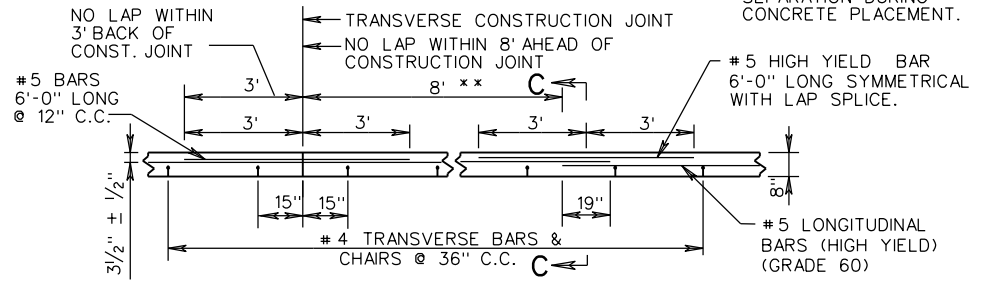

**SECTION B-B
EXTRA BAR METHOD**

** DOUBLE LAP REQUIREMENT (38") AND THE EXTRA BAR METHOD APPLY ONLY TO LAPS FALLING WITHIN AN AREA OF 8' BEYOND THE CONSTRUCTION JOINT.

SPECIFICATION REFERENCE

316

A COPY OF THE ORIGINAL SEALED AND SIGNED DRAWING IS ON FILE IN THE CENTRAL OFFICE.

**8" THICK CONTINUOUSLY REINFORCED CONC. PAVE.
(STEEL BAR REINFORCEMENT)**
VIRGINIA DEPARTMENT OF TRANSPORTATION

VDOT

ROAD AND BRIDGE STANDARDS

REVISION DATE
7/12

SHEET 2 OF 4
301.07

PR-3

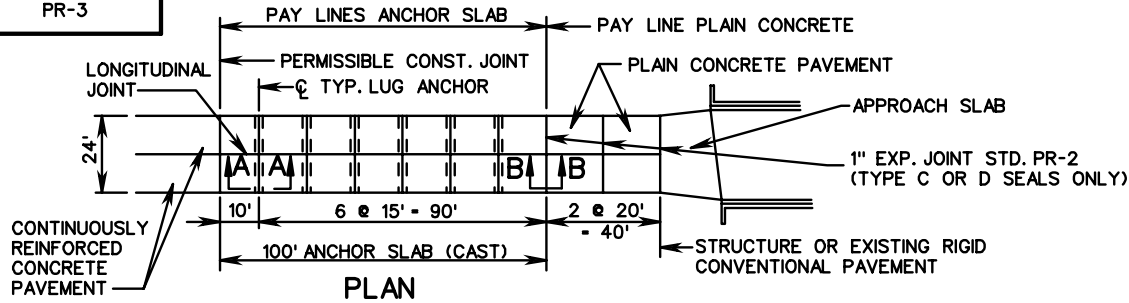

NOTES:

CONCRETE FOR LUG ANCHORS SHALL BE POURED AGAINST COMPACTED SUBGRADE. CONCRETE FOR LUGS AND ANCHOR SLAB MAY BE POURED MONOLITHICALLY OR POURED USING RAISED KEY CONSTRUCTION JOINT METHOD.

ADEQUATE CONSOLIDATION OF CONCRETE IN LUGS WILL BE OBTAINED WITHOUT DISPLACING LONGITUDINAL CONTINUOUS STEEL, BY THE USE OF INTERNAL VIBRATION.

WHEN LESS THAN FULL WIDTH LUG AND PAVEMENT SLAB IS PLACED, THE # 5 TRANSVERSE STEEL IN THE LUGS SHALL BE EXTENDED, LAPPED AND SPLICED IN AT LEAST 25 DIAMETERS.

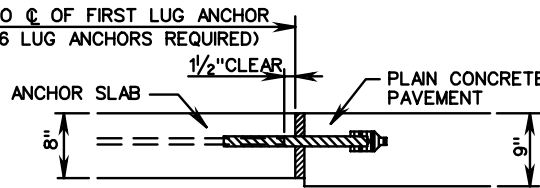
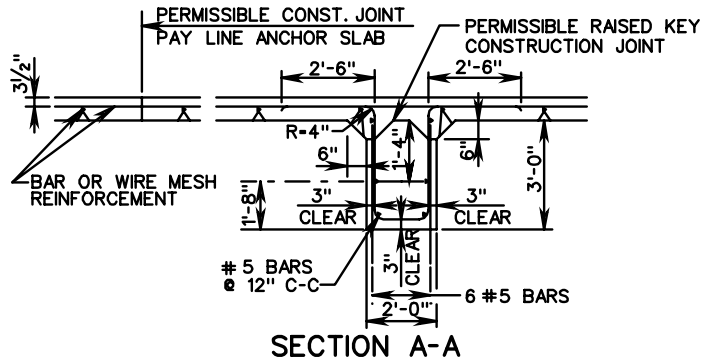

NOTES: FOR DOWEL & JOINT DETAILS SEE DETAIL OF TRANSVERSE EXPANSION JOINT PR-2

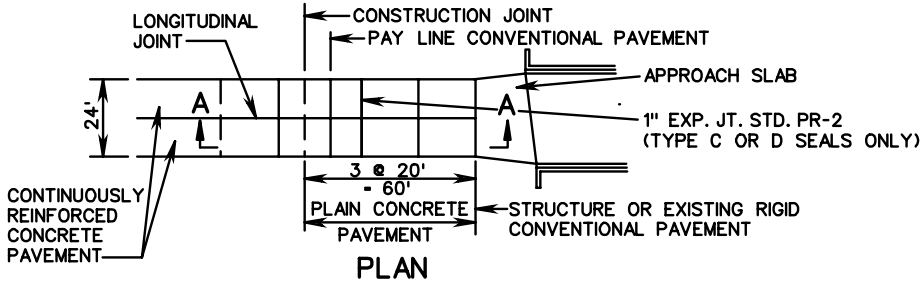
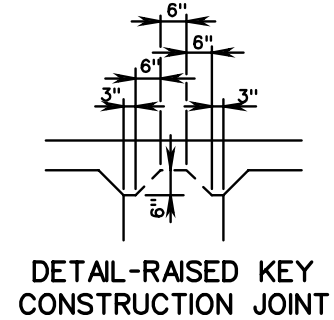

WF BEAM (WEIGHT AND DIMENSIONS)					
CRCP THICKNESS	EMBEDMENT IN "SUB SLAB"	WF BEAM SIZE	FLANGE		WEB THICKNESS
			WIDTH	THICKNESS	
8"	6"	14 X 61	10"	5/8"	3/8"

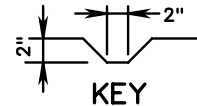

NOTES:

CONCRETE SHOULD BE ADEQUATELY VIBRATED UNDER BEAM FLANGE TO ELIMINATE HONEYCOMB.

2" MIN. CONCRETE COVER FOR STEEL IN SUB-SLAB.

WELDED 1/4" STEEL PLATE AT BOTH ENDS OF WF BEAM TO SEAL ENDS.

▨ DENOTES 1" EXPANSION JOINT MATERIAL POLYSTYRENE OR EQUIVALENT)

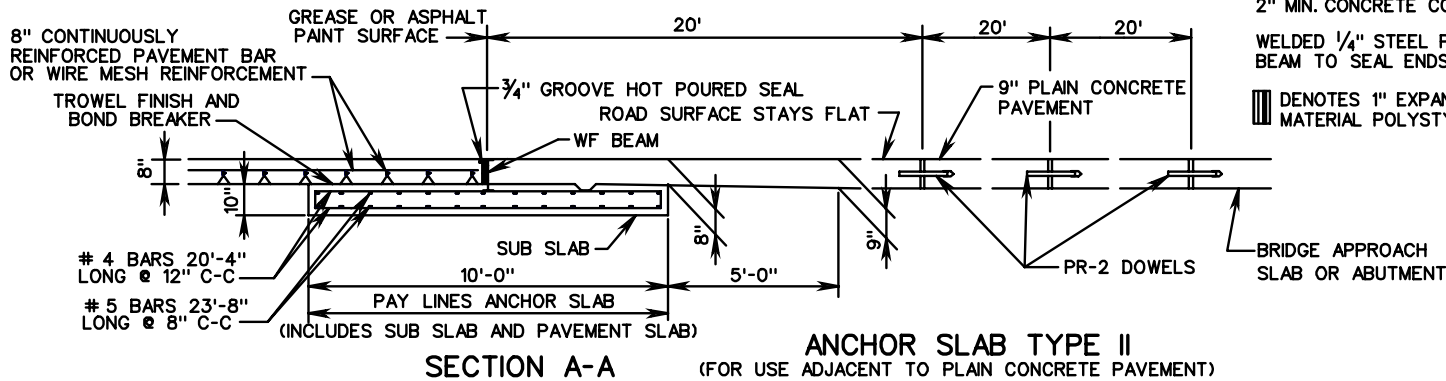

ROAD AND BRIDGE STANDARDS

SHEET 3 OF 4

REVISION DATE

301.08

8" THICK CONTINUOUSLY REINFORCED CONC. PAVE.

(FOR USE WITH BAR OR WIRE MESH REINFORCEMENT)

VIRGINIA DEPARTMENT OF TRANSPORTATION

SPECIFICATION REFERENCE

316

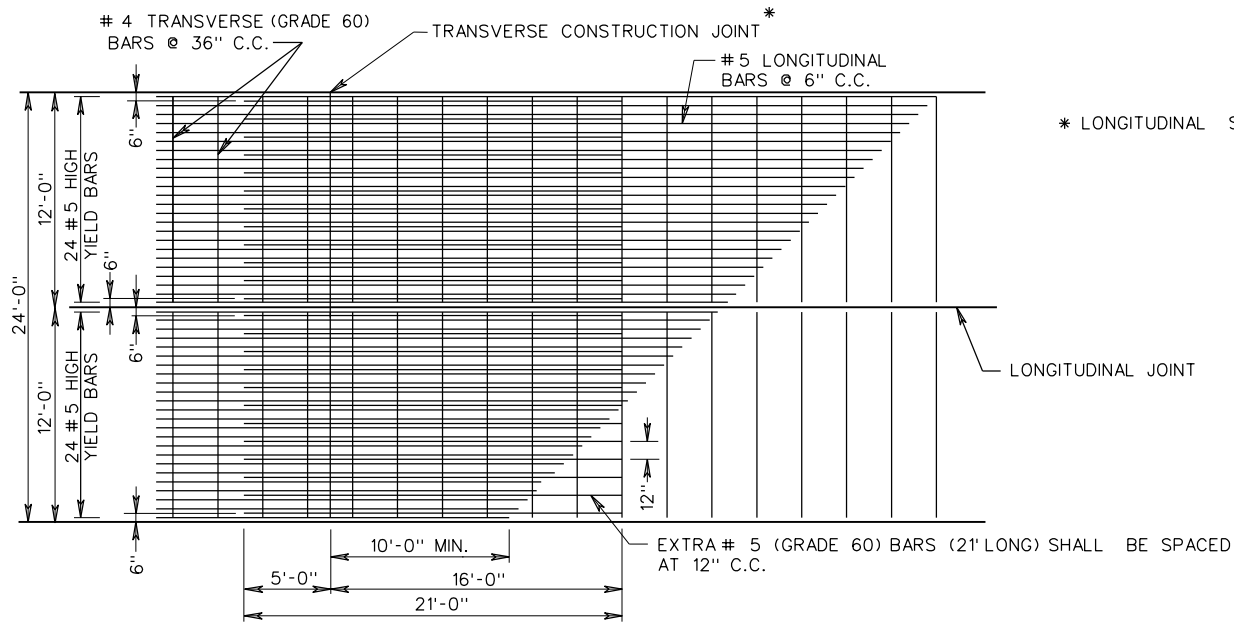

* LONGITUDINAL STEEL TO CONTINUE THROUGH JOINT.

LEAVE OUT JOINT
FOR USE WITH STEEL BAR REINFORCEMENT

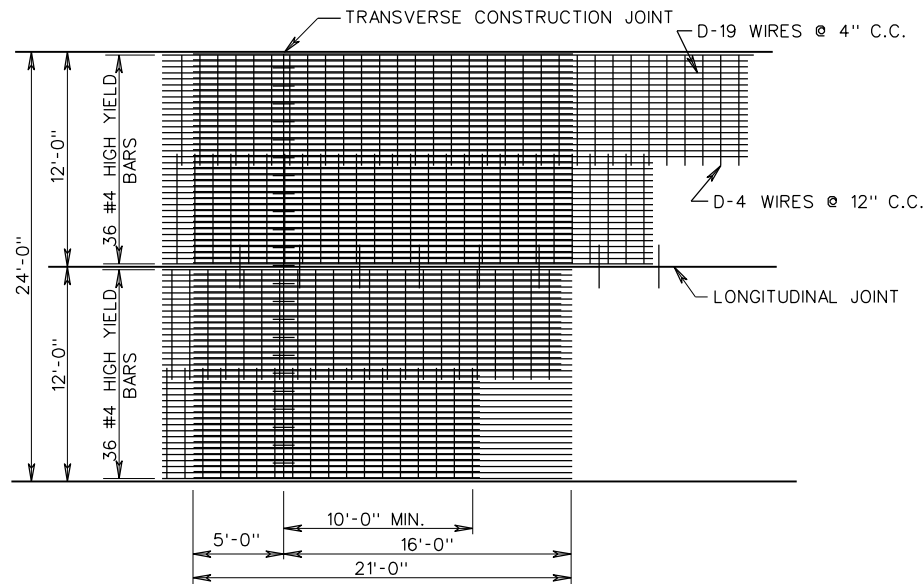

LEAVE OUT JOINT
FOR USE WITH WIRE MESH REINFORCEMENT

SPECIFICATION
REFERENCE

316

A COPY OF THE ORIGINAL SEALED AND SIGNED DRAWING IS ON FILE IN THE CENTRAL OFFICE.

8" THICK CONTINUOUSLY REINFORCED CONC. PAVE.
(LEAVE OUT JOINT DETAIL)

VIRGINIA DEPARTMENT OF TRANSPORTATION

VDOT

ROAD AND BRIDGE STANDARDS

REVISION DATE

7/12

SHEET 4 OF 4

301.09



NOTES:

HOOK BOLTS OR TIE BARS ARE TO BE PLACED IN THE SAME HORIZONTAL PLANE AS #5 TRANSVERSE BARS. WHERE NECESSARY ADJUST THE LOCATION OF HOOK BOLTS OR TIE BARS TO A 2 1/2" MINIMUM CLEARANCE BETWEEN HOOK BOLTS OR TIE BARS AND TRANSVERSE BARS.

TRANSVERSE CONSTRUCTION JOINT BARS ARE TO BE PLACED IN THE SAME HORIZONTAL PLANE AS #6 LONGITUDINAL BARS.

#6 LONGITUDINAL BARS ARE TO BE LAPPED AND TIED IN THE SAME HORIZONTAL PLANE.

FOR 36" WIDTH PAVEMENT USE SINGLE 12' LANES WITH 2 LONGITUDINAL CONSTRUCTION JOINTS OR 12' AND 24' LANES WITH ONE LONGITUDINAL CONSTRUCTION JOINT AND ONE GROOVED LONGITUDINAL JOINT. TRANSVERSE BARS SHALL NOT EXTEND THROUGH LONGITUDINAL CONSTRUCTION JOINTS, BUT SHALL EXTEND FULL LENGTH (23'-9") FOR GROOVED LONGITUDINAL JOINTS.

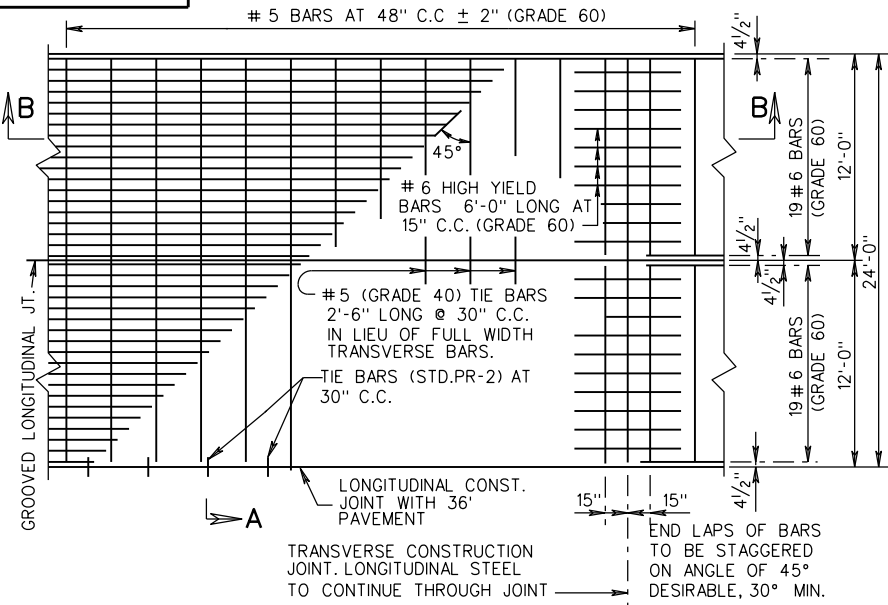
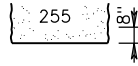

PLAN VIEW

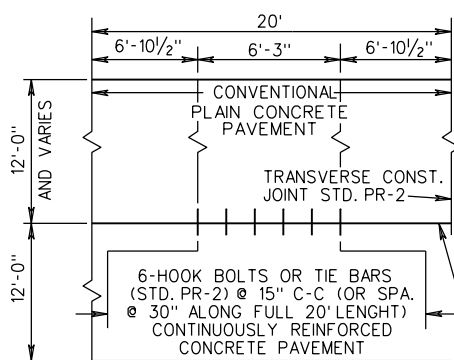

PLAN-RAMP & MAIN LINE CONNECTION

SMOOTH SURFACE TO BE STEEL TROWELED 8" IN FROM THE EDGE OF PAVEMENT EVERY 500 FEET, AND STATION NUMBER STAMPED ON IT.

THE DATE IS TO BE SHOWN IN A SIMILAR MANNER AT THE BEGINNING OF EACH DAYS POUR.

BOTH OUTSIDE EDGES OF DIVIDED HIGHWAY TO BE STAMPED. ONE EDGE OF UNDIVIDED HIGHWAY WHERE FEASIBLE. (TRAVEL LANE)

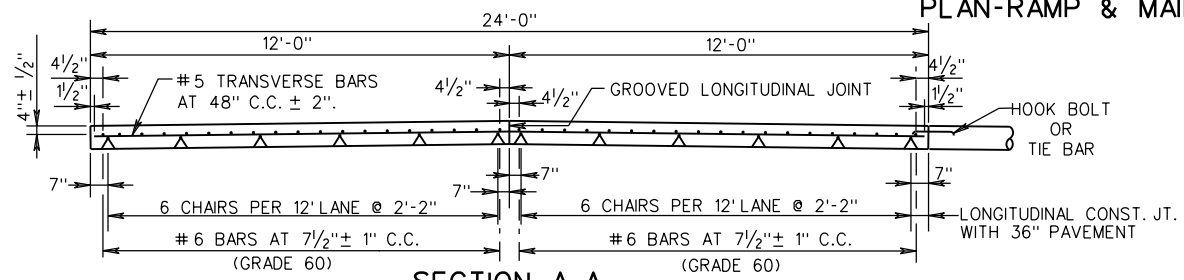

SECTION A-A

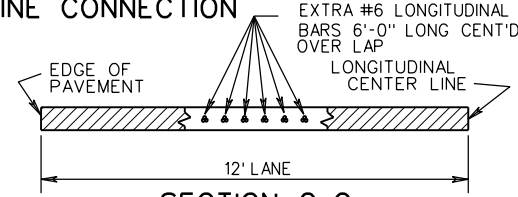

SECTION C-C

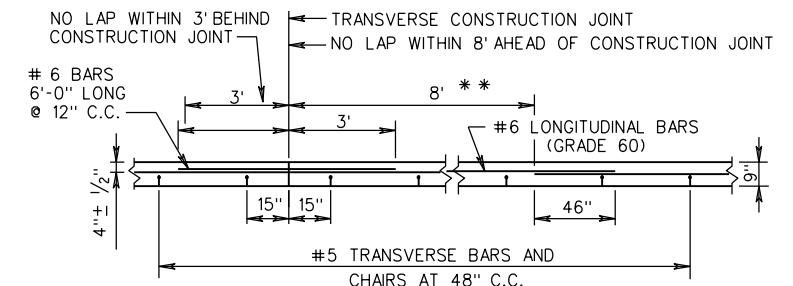

SECTION B-B
DOUBLE LAP METHOD

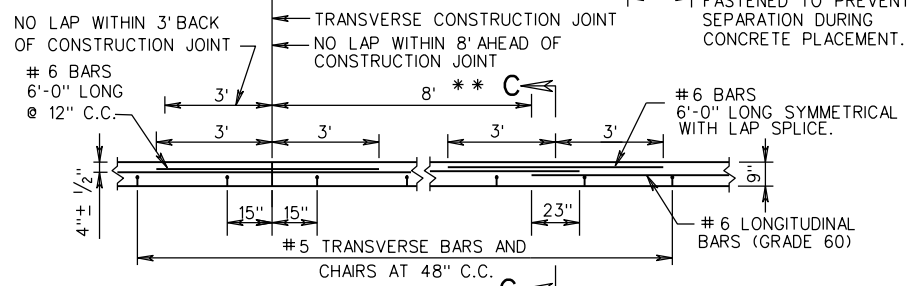

SECTION B-B
EXTRA BAR METHOD

** DOUBLE LAP REQUIREMENT (46") AND THE EXTRA BAR METHOD APPLY ONLY TO LAPS FALLING WITHIN AN AREA OF 8' BEYOND THE CONSTRUCTION JOINT.



ROAD AND BRIDGE STANDARDS

A COPY OF THE ORIGINAL SEALED AND SIGNED DRAWING IS ON FILE IN THE CENTRAL OFFICE.

9" THICK CONTINUOUSLY REINFORCED CONC. PAVE.
(STEEL BAR REINFORCEMENT)

SPECIFICATION REFERENCE

SHEET 1 OF 3

REVISION DATE

VIRGINIA DEPARTMENT OF TRANSPORTATION

316

301.10

7/12

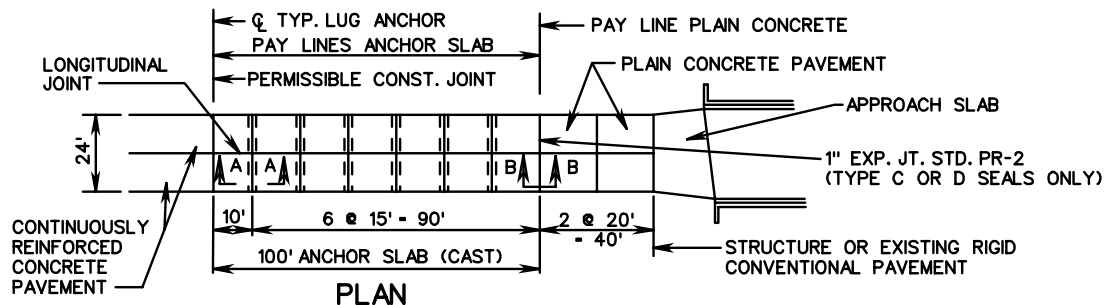

NOTES:
 CONCRETE FOR LUG ANCHORS SHALL BE POURED AGAINST COMPACTED SUBGRADE. CONCRETE FOR LUGS AND ANCHOR SLAB MAY BE POURED MONOLITHICALLY OR POURED USING RAISED KEY CONSTRUCTION JOINT METHOD.

ADEQUATE CONSOLIDATION OF CONCRETE IN LUGS WILL BE OBTAINED WITHOUT DISPLACING LONGITUDINAL CONTINUOUS STEEL, BY THE USE OF INTERNAL VIBRATION.

WHEN LESS THAN FULL WIDTH LUG AND PAVEMENT SLAB IS PLACED, THE #5 TRANSVERSE STEEL IN THE LUGS SHALL BE EXTENDED, LAPPED AND SPLICED AT LEAST 25 DIAMETERS.

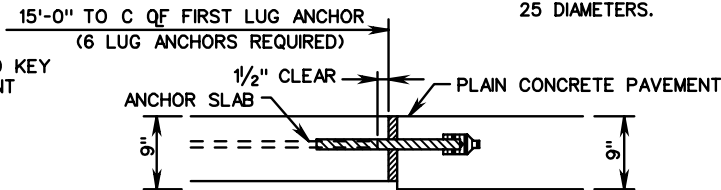
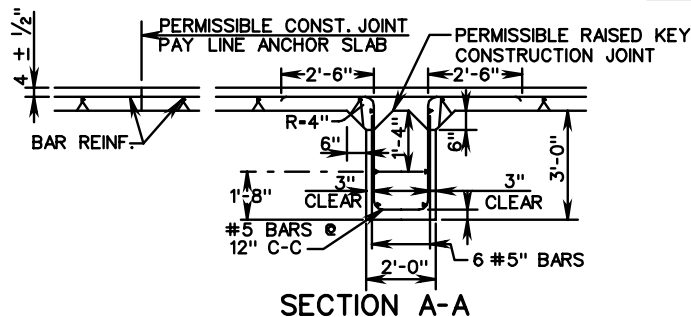

NOTE: FOR DOWEL & JOINT DETAILS SEE DETAIL OF TRANSVERSE EXPANSION JOINT PR-2

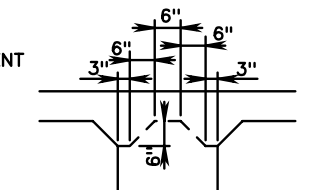

DETAIL-RAISED KEY CONSTRUCTION JOINT

SECTION B-B
 ANCHOR SLAB TYPE I
 (FOR USE ADJACENT TO PLAIN CONCRETE PAVEMENT)

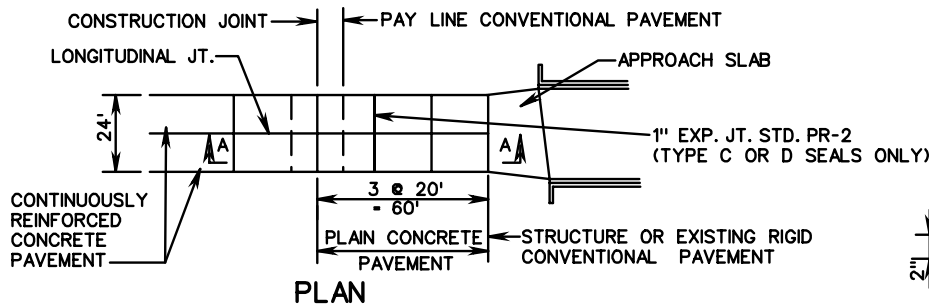

WF BEAM (WEIGHT AND DIMENSIONS)					
CRCP THICKNESS	EMBEDMENT IN "SUB SLAB"	WF BEAM SIZE	FLANGE		WEB THICKNESS
			WIDTH	THICKNESS	
9"	6"	14 X 61	10"	5/8"	3/8"

NOTES:
 CONCRETE SHOULD BE ADEQUATELY VIBRATED UNDER BEAM FLANGE TO ELIMINATE HONEYCOMB.
 2" MIN. CONCRETE COVER FOR STEEL IN SUB-SLAB.
 WELDED 1/4" STEEL PLATE AT BOTH ENDS OF WF BEAM TO SEAL ENDS.

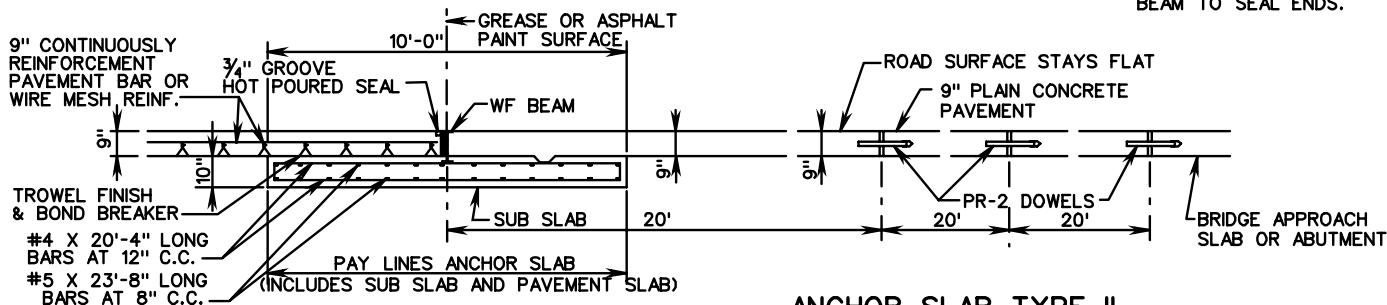
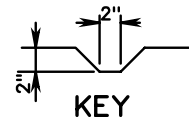

SECTION A-A
 ANCHOR SLAB TYPE II
 (FOR USE ADJACENT TO PLAIN CONCRETE PAVEMENT)

■ DENOTES 1" EXPANSION JOINT MATERIAL (POLYSTYRENE OR EQUIVALENT)

SPECIFICATION REFERENCE

9" THICK CONTINUOUSLY REINFORCED CONC. PAVE.
 (FOR USE WITH BAR REINFORCEMENT ONLY)

316

VIRGINIA DEPARTMENT OF TRANSPORTATION

VDOT

ROAD AND BRIDGE STANDARDS

REVISION DATE

SHEET 2 OF 3

301.11

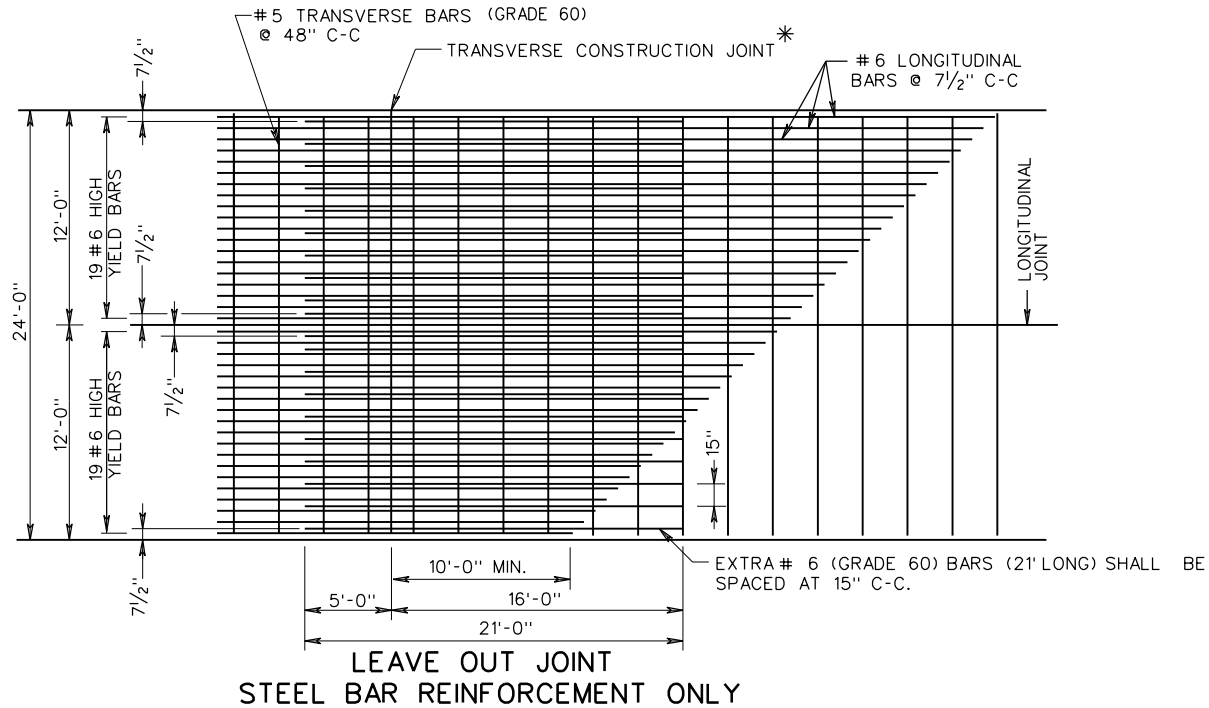

* LONGITUDINAL STEEL TO CONTINUE THROUGH JOINT.



ROAD AND BRIDGE STANDARDS

SHEET 3 OF 3

REVISION DATE

301.12

7/12

A COPY OF THE ORIGINAL SEALED AND SIGNED DRAWING IS ON FILE IN THE CENTRAL OFFICE.

**9" THICK CONTINUOUSLY REINFORCED CONC. PAVE.
(LEAVE OUT JOINT DETAIL)**

VIRGINIA DEPARTMENT OF TRANSPORTATION

SPECIFICATION
REFERENCE

316

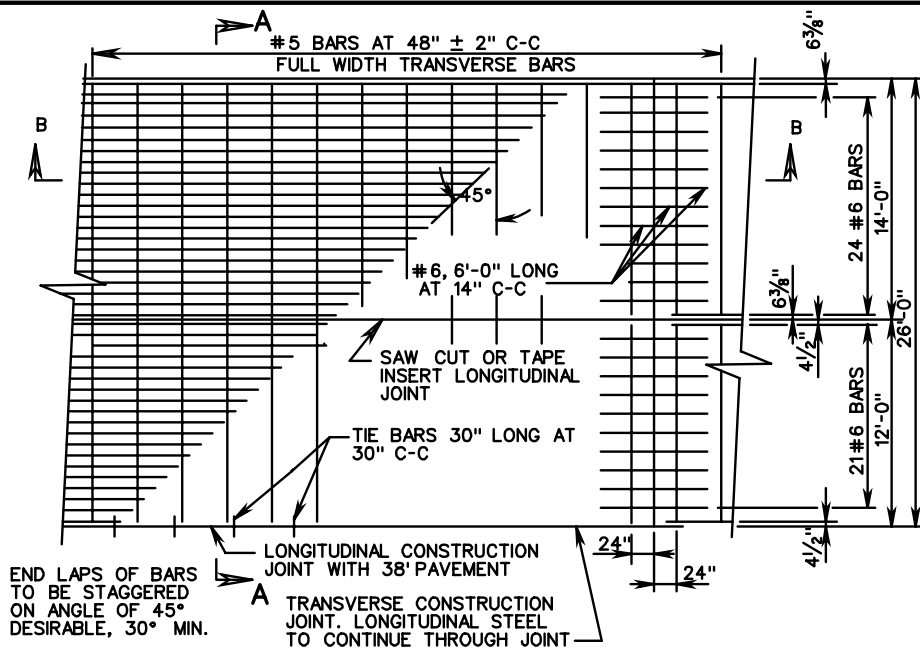

PLAN VIEW
CONTINUOUSLY REINFORCED CONCRETE PAVEMENT

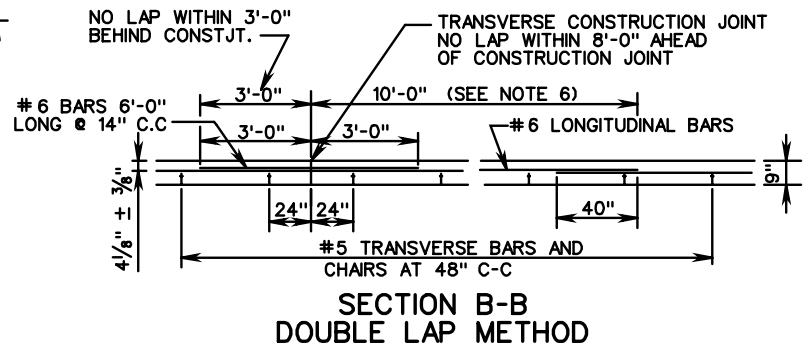

SECTION B-B
DOUBLE LAP METHOD

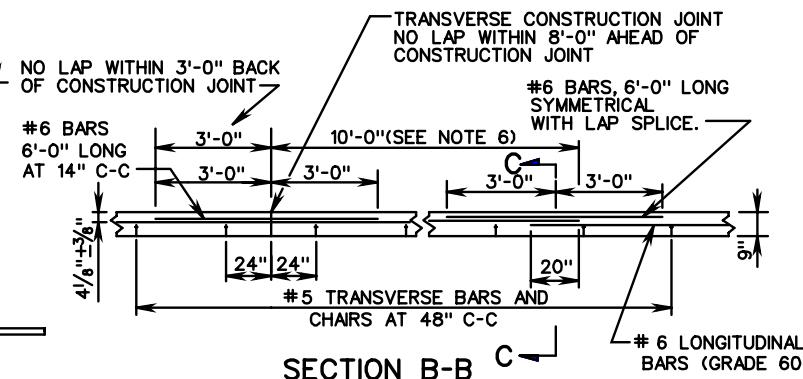

SECTION B-B C
EXTRA BAR METHOD

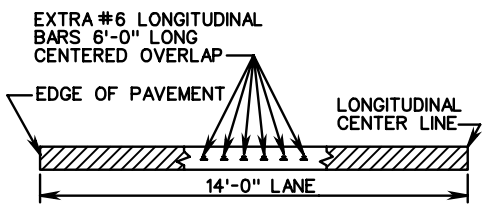

SECTION C-C

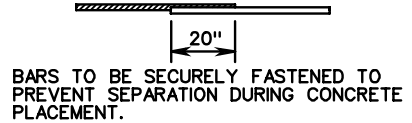

TYPICAL
LONGITUDINAL LAP

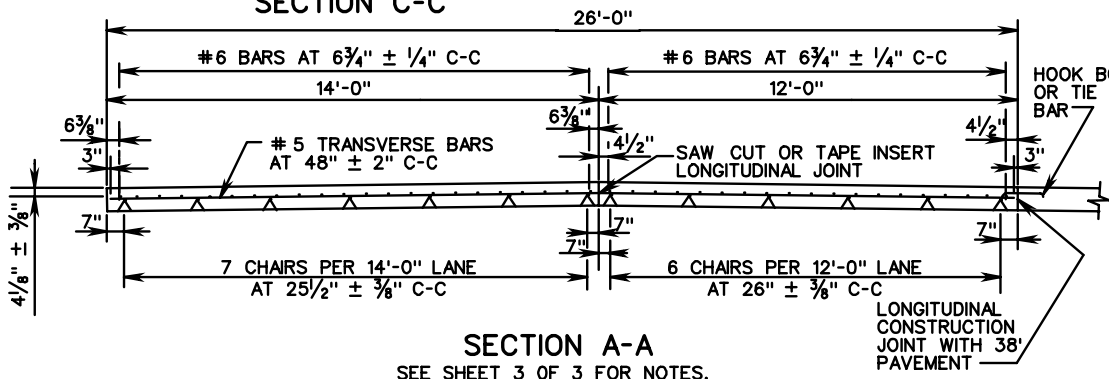

SECTION A-A
SEE SHEET 3 OF 3 FOR NOTES.

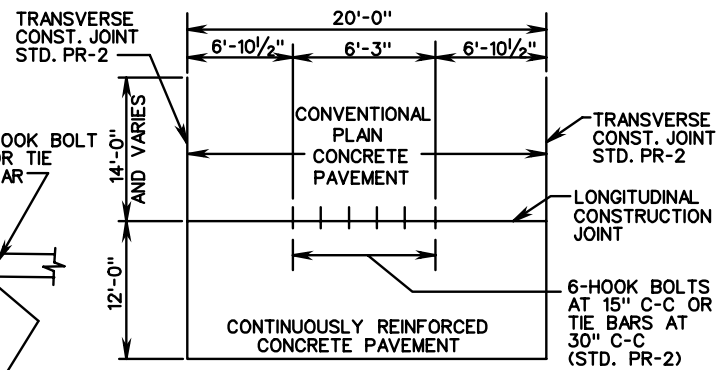

PLAN-RAMP & MAIN LINE CONNECTION

SPECIFICATION REFERENCE
316

9" THICK CONTINUOUSLY REINFORCED CONC. PAVE.
(14 FOOT TRAVEL LANE)
VIRGINIA DEPARTMENT OF TRANSPORTATION

VDOT ROAD AND BRIDGE STANDARDS	
REVISION DATE	SHEET 1 OF 3
301.13	

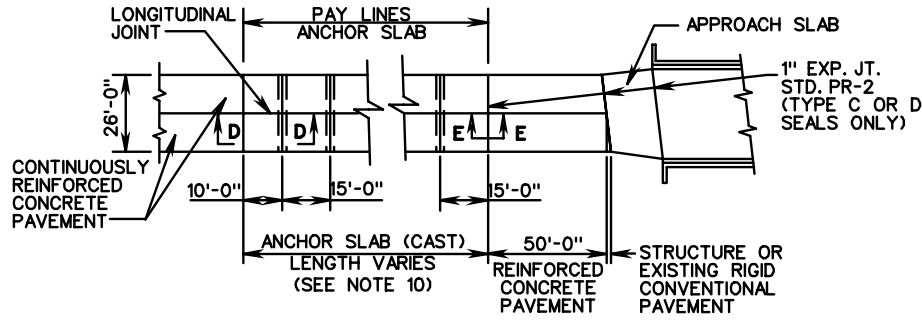

PLAN VIEW ANCHOR SLAB TYPE I

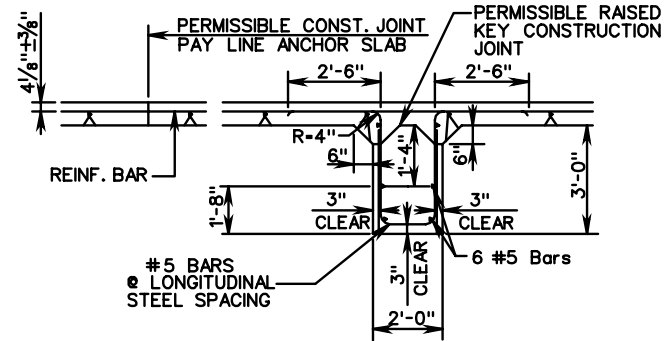

SECTION D-D

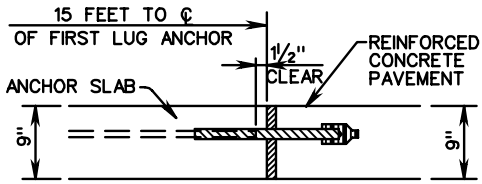

FOR DOWEL & JOINT DETAILS SEE DETAIL OF TRANSVERSE EXPANSION JOINT PR-2

SECTION E-E ANCHOR SLAB TYPE I

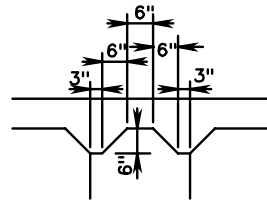

DETAIL-RAISED KEY CONSTRUCTION JOINT

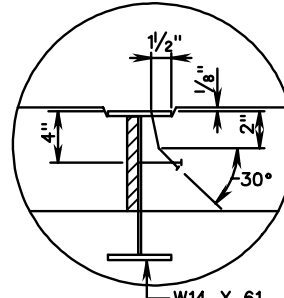

DETAIL A

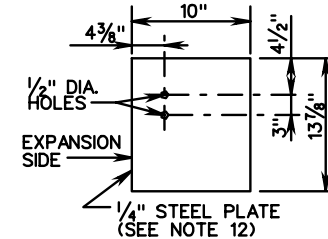

END PLATE DETAIL ANCHOR SLAB TYPE II

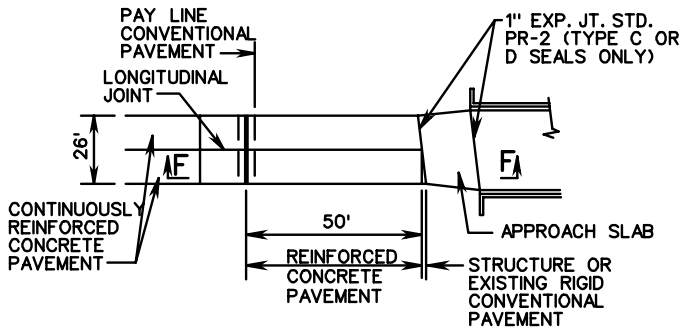

PLAN VIEW ANCHOR SLAB TYPE II (SEE NOTE 11)

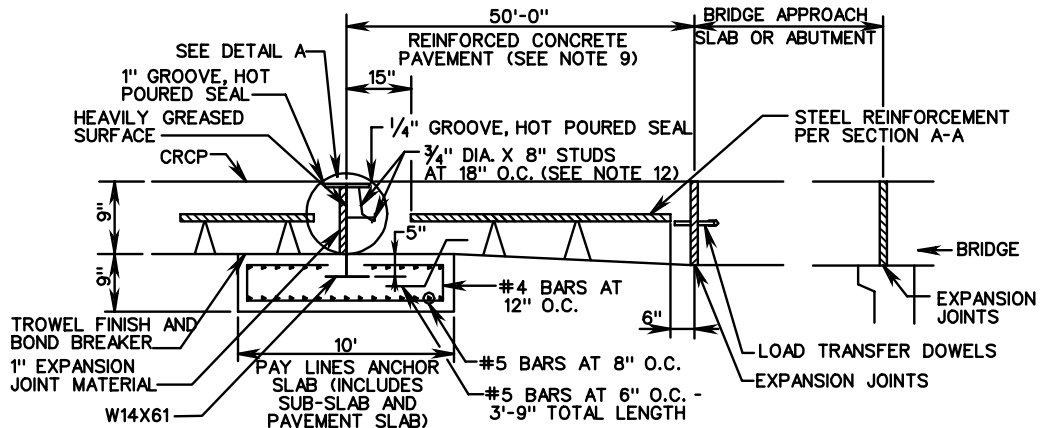

SECTION F-F ANCHOR SLAB TYPE II

SEE SHEET 3 OF 3 FOR NOTES.



ROAD AND BRIDGE STANDARDS

SHEET 2 OF 3

REVISION DATE

301.14

9" THICK CONTINUOUSLY REINFORCED CONC. PAVE.

(14 FOOT TRAVEL LANE)

VIRGINIA DEPARTMENT OF TRANSPORTATION

SPECIFICATION REFERENCE

316

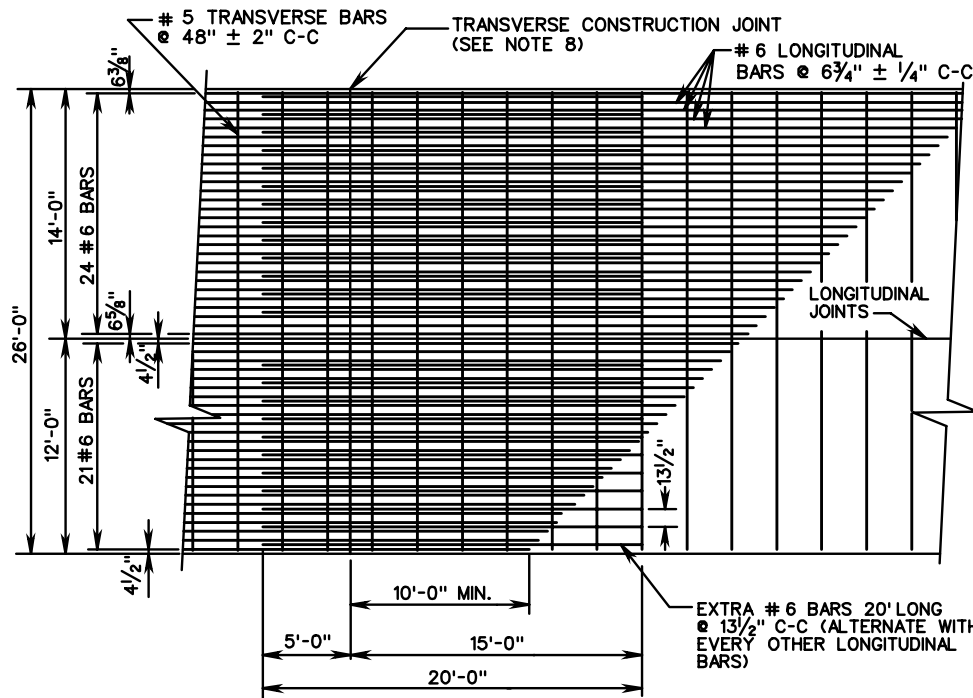

PLAN VIEW
LEAVE OUT JOINT
STEEL BAR REINFORCEMENT ONLY

NOTES:

1. HOOK BOLTS OR TIE BARS ARE TO BE PLACED IN THE SAME HORIZONTAL PLANE AS THE # 5 TRANSVERSE BARS. WHERE NECESSARY, ADJUST THE LOCATION OF THE HOOK BOLTS OR TIE BARS TO A 2 1/2" MINIMUM CLEARANCE BETWEEN HOOK BOLTS OR TIE BARS AND TRANSVERSE BARS.
2. TRANSVERSE CONSTRUCTION JOINT BARS ARE TO BE PLACED IN THE SAME HORIZONTAL PLANE AS THE #6 LONGITUDINAL BARS.
3. # 6 LONGITUDINAL BARS ARE TO BE LAPPED AND TIED IN THE SAME HORIZONTAL PLANE.
4. FOR THE 38 FOOT WIDTH PAVEMENT USE SINGLE 12 FOOT LANES WITH TWO LONGITUDINAL CONSTRUCTION JOINTS OR 12 FOOT AND 14 FOOT LANES WITH ONE LONGITUDINAL CONSTRUCTION JOINT AND ONE SAW CUT OR TAPE INSERT LONGITUDINAL JOINT. TRANSVERSE BARS SHALL NOT EXTEND THROUGH LONGITUDINAL CONSTRUCTION JOINTS, BUT SHALL EXTEND FULL LENGTH (25'-6") FOR SAW CUT OR TAPE INSERT LONGITUDINAL JOINT.
5. SMOOTH SURFACE TO BE STEEL TROWELED 8" IN FROM EDGE OF PAVEMENT EVERY 500 FT., AND THE STATION NUMBER STAMPED INTO IT AS SHOWN BELOW. THE DATE IS TO BE SHOWN IN A SIMILIAR MANNER AT THE BEGINNING OF EACH DAYS POUR. BOTH OUTSIDE EDGES OF DIVIDED HIGHWAY IS TO BE STAMPED. ONE EDGE OF UNDIVIDED HIGHWAY WHERE FEASIBLE (TRAVEL LANE).
6. DOUBLE LAP REQUIREMENT (40") AND THE EXTRA BAR METHOD APPLY ONLY TO LAPS FALLING WITHIN AN AREA OF 10' BEYOND THE CONSTRUCTION JOINT.
7. CONCRETE FOR LUG ANCHORS SHALL BE POURED AGAINST COMPACTED SUBGRADE. CONCRETE FOR LUGS AND ANCHOR SLAB MAY BE POURED MONOLITHICALLY OR POURED USING RAISED KEY CONSTRUCTION JOINT METHOD. ADEQUATE CONSOLIDATION OF CONCRETE IN LUGS WILL BE OBTAINED WITHOUT DISPLACING LONGITUDINAL CONTINUOUS STEEL, BY THE USE OF INTERNAL VIBRATION. WHEN LESS THAN FULL WIDTH LUG AND PAVEMENT SLAB IS PLACED, THE # 5 TRANSVERSE STEEL IN THE LUGS SHALL BE EXTENDED, LAPPED AND SPLICED AT LEAST 25 DIAMETERS.
8. LONGITUDINAL STEEL TO CONTINUE THROUGH JOINT. EXTRA #6 BARS 20' LONG SHALL BE SPACED AT 13 1/2" C-C.
9. CONCRETE SHOULD BE ADEQUATELY VIBRATED UNDER BEAM FLANGE TO ELIMINATE HONEYCOMBS.
10. IN CONDITIONS OF SOFT CLAY UNDERLYING SOILS (AASHTO SOIL CLASSIFICATION OF GROUP A-4, A-5, A-6, OR A-7) INCLUSIVE OF SUBGROUPS (PER AASHTO MATERIALS SPECIFICATIONS M 145), AN ANCHOR SLAB TYPE I UTILIZING 5 ANCHOR LUGS (ANCHOR SLAB LENGTH = 85') OR AN ANCHOR SLAB TYPE II SHALL BE USED. REINFORCEMENT STEEL SIZE AND SPACING WILL BE THE SAME AS THE CONTINUOUS CONCRETE PAVEMENT.

IN CONDITIONS OF GRANULAR UNDERLYING SOILS ONLY (AASHTO SOIL CLASSIFICATION OF GROUP A-1, A-2, OR A-3) INCLUSIVE OF SUBGROUPS (PER AASHTO MATERIALS SPECIFICATIONS M 145), AN ANCHOR SLAB TYPE I UTILIZING 3 ANCHOR LUGS (ANCHOR SLAB LENGTH = 55') OR AN ANCHOR SLAB TYPE II MAY BE USED. REINFORCEMENT STEEL SIZE AND SPACING WILL BE THE SAME AS THE CONTINUOUS CONCRETE PAVEMENT.
11. WELD STEEL END PLATE TO BOTH ENDS OF WF BEAM TO SEAL ENDS. WELD SHEAR CONNECTORS TO WEB AND FLANGE OF WF BEAM.
12. 2 INCH MINIMUM CONCRETE COVER FOR STEEL IN SUB-SLABS.
13. WIDE FLANGE BEAM TO BE TREATED WITH CORROSION INHIBITOR PER SECTION 407 OF THE ROAD AND BRIDGE SPECIFICATIONS.
14. ALL REINFORCED BARS SHALL BE GRADE 60 STEEL.
15. THE USE OF TUBE FEEDING TO PLACE REINFORCEMENT IN PLASTIC CONCRETE WILL NOT BE ALLOWED.

SPECIFICATION REFERENCE 316	<h2 style="margin: 0;">9" THICK CONTINUOUSLY REINFORCED CONC. PAVE.</h2> <p style="margin: 0;">(14 FOOT TRAVEL LANE)</p> <p style="margin: 0;">VIRGINIA DEPARTMENT OF TRANSPORTATION</p>	ROAD AND BRIDGE STANDARDS REVISION DATE SHEET 3 OF 3 301.15
---------------------------------------	--	--

PR-6

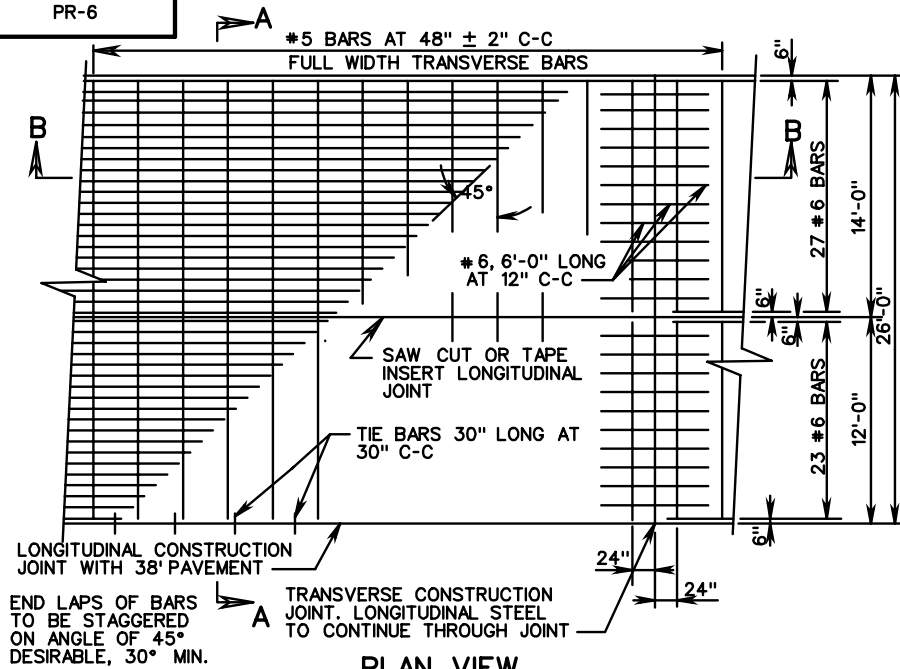

PLAN VIEW
CONTINUOUSLY REINFORCED CONCRETE PAVEMENT

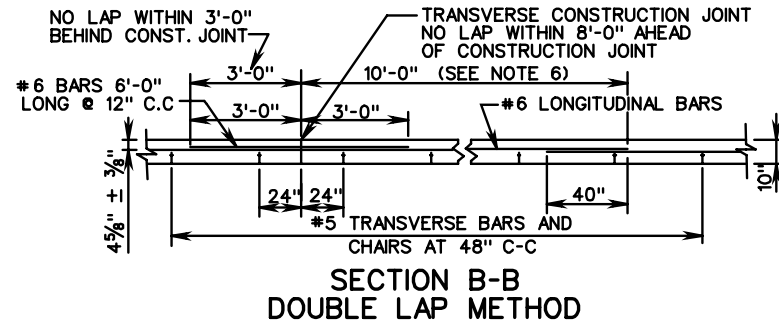

SECTION B-B
DOUBLE LAP METHOD

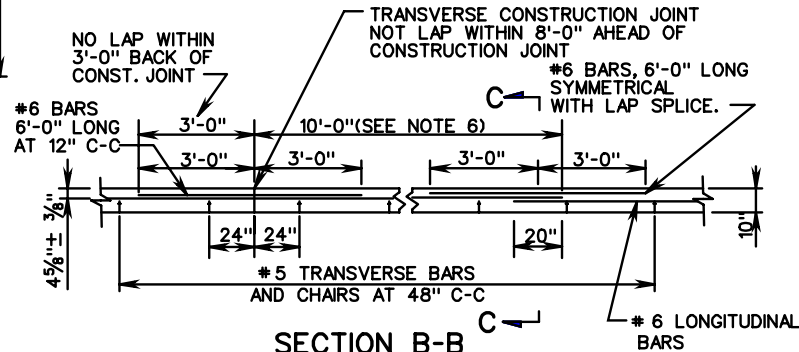

SECTION B-B
EXTRA BAR METHOD

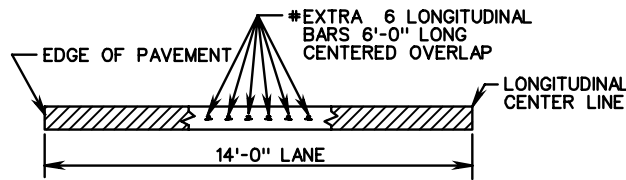

SECTION C-C

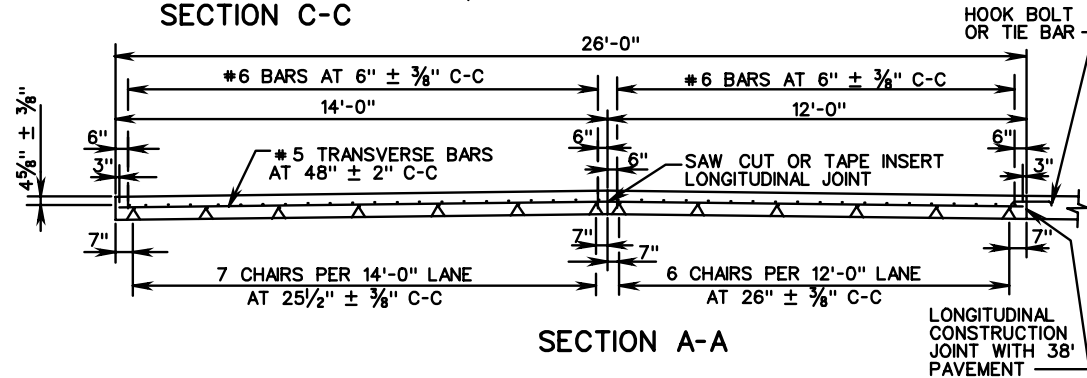
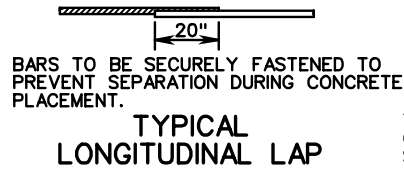

SECTION A-A

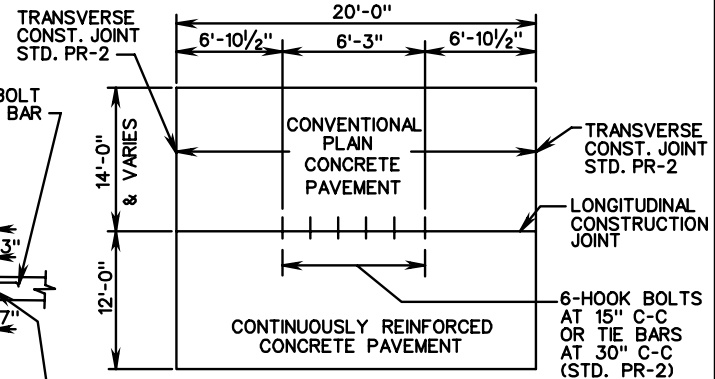

PLAN-RAMP & MAIN LINE CONNECTION

SEE SHEET 3 OF 3 FOR NOTES.



ROAD AND BRIDGE STANDARDS

SHEET 1 OF 3

REVISION DATE

301.16

10" THICK CONTINUOUSLY REINFORCED CONC. PAVE.
(14 FOOT TRAVEL LANE)

VIRGINIA DEPARTMENT OF TRANSPORTATION

SPECIFICATION REFERENCE

316

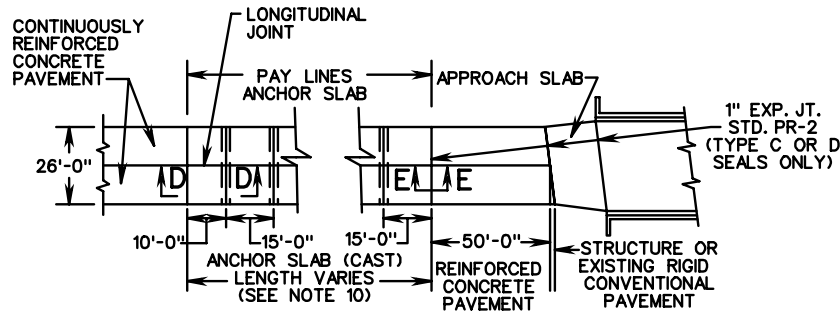

PLAN VIEW
ANCHOR SLAB TYPE I

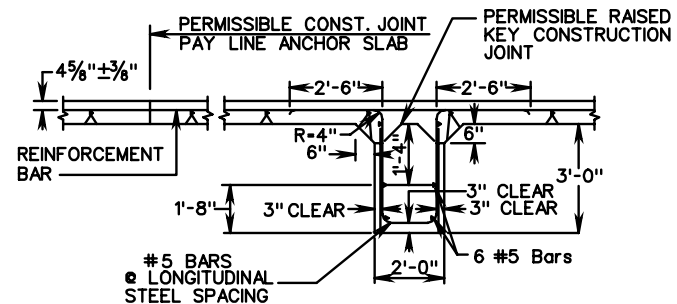

SECTION D-D

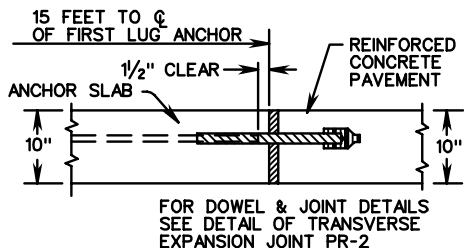

SECTION E-E
ANCHOR SLAB TYPE I

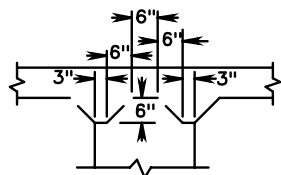

DETAIL-RAISED KEY
CONSTRUCTION JOINT

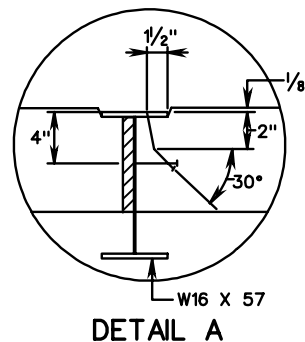

DETAIL A

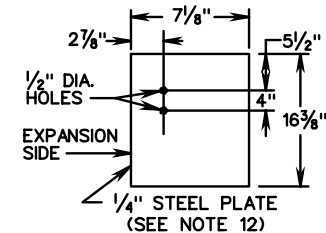

ANCHOR SLAB TYPE II
END PLATE DETAIL

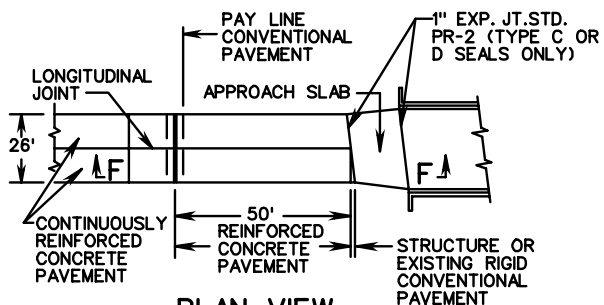

PLAN VIEW
ANCHOR SLAB TYPE II
(SEE NOTE 11)

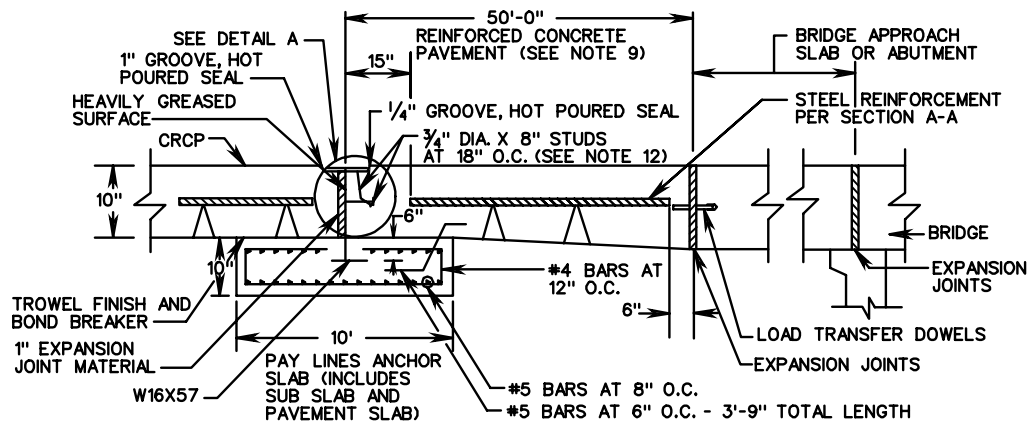

SECTION F-F
ANCHOR SLAB TYPE II

SEE SHEET 3 OF 3 FOR NOTES

SPECIFICATION REFERENCE

10" THICK COUNTINUOUSLY REINFORCED CONC. PAVE.
(14 FOOT TRAVEL LANE)

316

VIRGINIA DEPARTMENT OF TRANSPORTATION

VDOT

ROAD AND BRIDGE STANDARDS

REVISION DATE

SHEET 2 OF 3

301.17

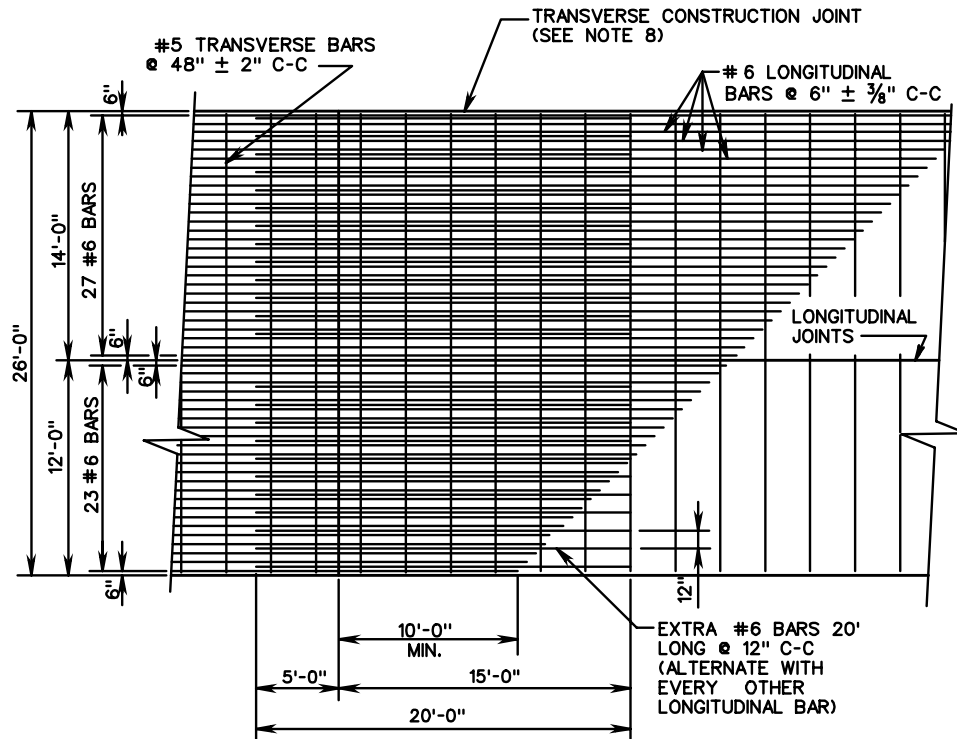

PLAN VIEW
LEAVE OUT JOINT
STEEL BAR REINFORCEMENT ONLY

NOTES:

1. HOOK BOLTS OR TIE BARS ARE TO BE PLACED IN THE SAME HORIZONTAL PLANE AS THE #5 TRANSVERSE BARS. WHERE NECESSARY, ADJUST THE LOCATION OF THE HOOK BOLTS OR TIE BARS TO A 2½" MINIMUM CLEARANCE BETWEEN HOOK BOLTS OR TIE BARS AND TRANSVERSE BARS.
2. TRANSVERSE CONSTRUCTION JOINT BARS ARE TO BE PLACED IN THE SAME HORIZONTAL PLANE AS THE #6 LONGITUDINAL BARS.
3. #6 LONGITUDINAL BARS ARE TO BE LAPPED AND TIED IN THE SAME HORIZONTAL PLANE.
4. FOR THE 38 FT. WIDTH PAVEMENT USE SINGLE 12 FOOT LANES WITH TWO LONGITUDINAL CONSTRUCTION JOINTS OR 12 FT. AND 14 FT. LANES WITH ONE LONGITUDINAL CONSTRUCTION JOINT AND ONE SAW CUT OR TAPE INSERT LONGITUDINAL JOINT. TRANSVERSE BARS SHALL NOT EXTEND THROUGH LONGITUDINAL CONSTRUCTION JOINTS, BUT SHALL EXTEND FULL LENGTH (25'-6") FOR SAW CUT OR TAPE INSERT LONGITUDINAL JOINT.
5. SMOOTH SURFACE TO BE STEEL TROWELED 8" IN FROM EDGE OF PAVEMENT EVERY 500 FT., AND THE STATION NUMBER STAMPED INTO IT AS SHOWN BELOW. THE DATE IS TO BE SHOWN IN A SIMILAR MANNER AT THE BEGINNING OF EACH DAYS POUR. BOTH OUTSIDE EDGES OF DIVIDED HIGHWAY IS TO BE STAMPED. ONE EDGE OF UNDIVIDED HIGHWAY WHERE FEASIBLE (TRAVEL LANE).
6. DOUBLE LAP REQUIREMENT (40") AND THE EXTRA BAR METHOD APPLY ONLY TO LAPS FALLING WITHIN AN AREA OF 10' BEYOND THE CONSTRUCTION JOINT.
7. CONCRETE FOR LUG ANCHORS SHALL BE POURED AGAINST COMPACTED SUBGRADE. CONCRETE FOR LUGS AND ANCHOR SLAB MAY BE POURED MONOLITHICALLY OR POURED USING RAISED KEY CONSTRUCTION JOINT METHOD. ADEQUATE CONSOLIDATION OF CONCRETE IN LUGS WILL BE OBTAINED WITHOUT DISPLACING LONGITUDINAL CONTINUOUS STEEL, BY THE USE OF INTERNAL VIBRATION. WHEN LESS THAN FULL WIDTH LUG AND PAVEMENT SLAB IS PLACED, THE #5 TRANSVERSE STEEL IN THE LUGS SHALL BE EXTENDED, LAPPED AND SPLICED AT LEAST 25 DIA.
8. LONGITUDINAL STEEL TO CONTINUE THROUGH JOINT. EXTRA #6 BARS 20' LONG SHALL BE SPACED AT 13½" C-C.
9. CONCRETE SHOULD BE ADEQUATELY VIBRATED UNDER BEAM FLANGE TO ELIMINATE HONEYCOMBS.
10. IN CONDITIONS OF SOFT CLAY UNDERLYING SOILS (AASHTO SOIL CLASSIFICATION OF GROUP A-4, A-5, A-6, OR A-7) INCLUSIVE OF SUBGROUPS (PER AASHTO MATERIALS SPECIFICATIONS M 145), AN ANCHOR SLAB TYPE I UTILIZING 5 ANCHOR LUGS (ANCHOR SLAB LENGTH = 85') OR AN ANCHOR SLAB TYPE II SHALL BE USED. REINFORCEMENT STEEL SIZE AND SPACING WILL BE THE SAME AS THE CONTINUOUS CONCRETE PAVEMENT.

IN CONDITIONS OF GRANULAR UNDERLYING SOILS ONLY (AASHTO SOIL CLASSIFICATION OF GROUP A-1, A-2, OR A-3) INCLUSIVE OF SUBGROUPS (PER AASHTO MATERIALS SPECIFICATIONS M 145), AN ANCHOR SLAB TYPE I UTILIZING 3 ANCHOR LUGS (ANCHOR SLAB LENGTH = 55') OR AN ANCHOR SLAB TYPE II MAY BE USED. REINFORCEMENT STEEL SIZE AND SPACING WILL BE THE SAME AS THE CONTINUOUS CONCRETE PAVEMENT.
11. WELD STEEL END PLATE TO BOTH ENDS OF WF BEAM TO SEAL ENDS. WELD SHEAR CONNECTORS TO WEB AND FLANGE OF WF BEAM.
12. 2 INCH MINIMUM CONCRETE COVER FOR STEEL IN SUB-SLABS.
13. WIDE FLANGE BEAM TO BE TREATED WITH CORROSION INHIBITOR PER SECTION 407 OF THE ROAD AND BRIDGE SPECIFICATIONS.
14. ALL REINFORCED BARS SHALL BE GRADE 60 STEEL.
15. THE USE OF TUBE FEEDING TO PLACE REINFORCEMENT IN PLASTIC CONCRETE WILL NOT BE ALLOWED.

VDOT

ROAD AND BRIDGE STANDARDS

SHEET 3 OF 3

REVISION DATE

301.18

10" THICK CONTINUOUSLY REINFORCED CONC. PAVE.
(14 FOOT TRAVEL LANE)

VIRGINIA DEPARTMENT OF TRANSPORTATION

SPECIFICATION
REFERENCE

316

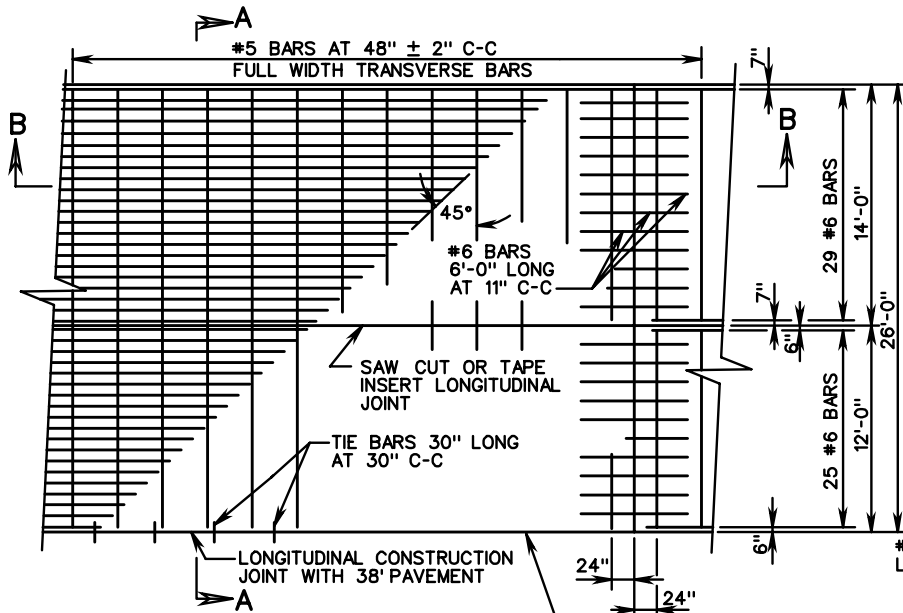

PLAN VIEW
CONTINUOUSLY REINFORCED CONCRETE PAVEMENT

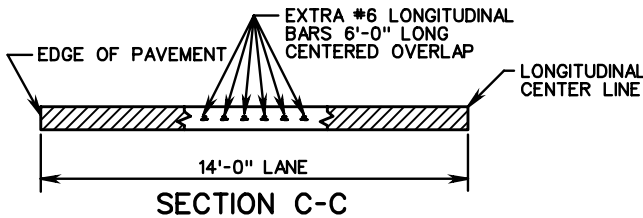

SECTION C-C



TYPICAL LONGITUDINAL LAP
BARS TO BE SECURELY FASTENED TO PREVENT SEPARATION DURING CONCRETE PLACEMENT.

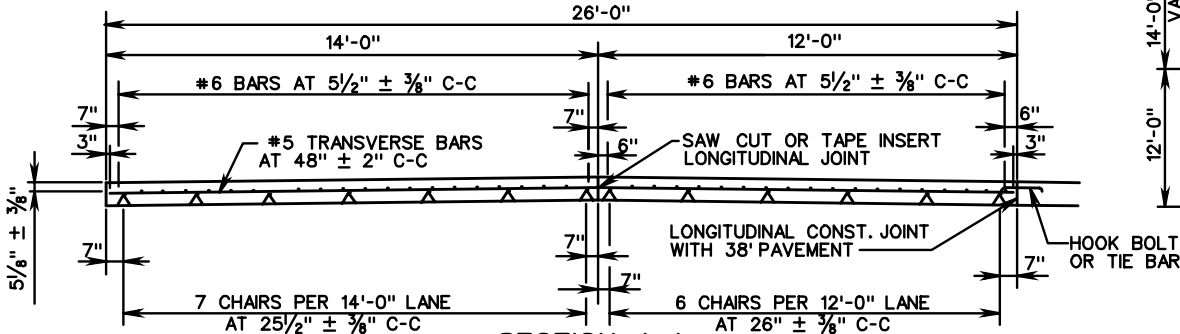

SECTION A-A

SEE SHEET 3 OF 3 FOR NOTES

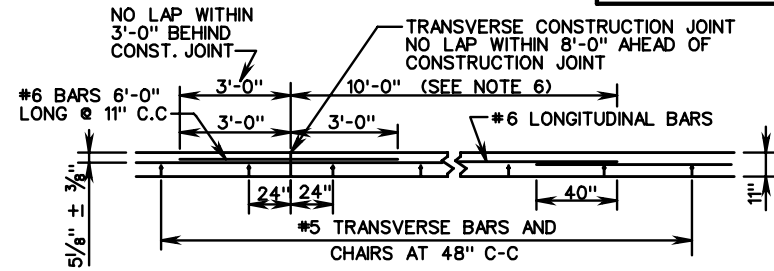

SECTION B-B
DOUBLE LAP METHOD

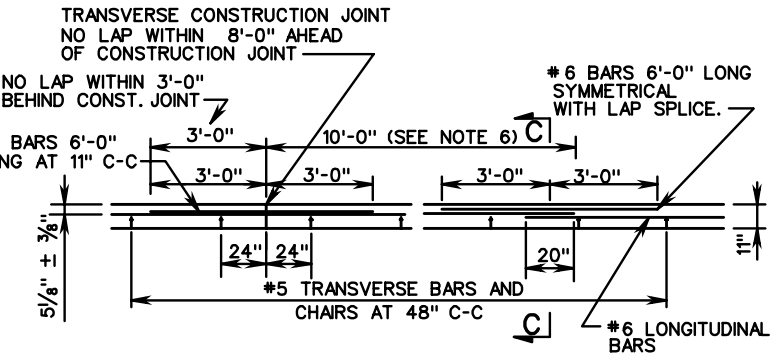

SECTION B-B
EXTRA BAR METHOD

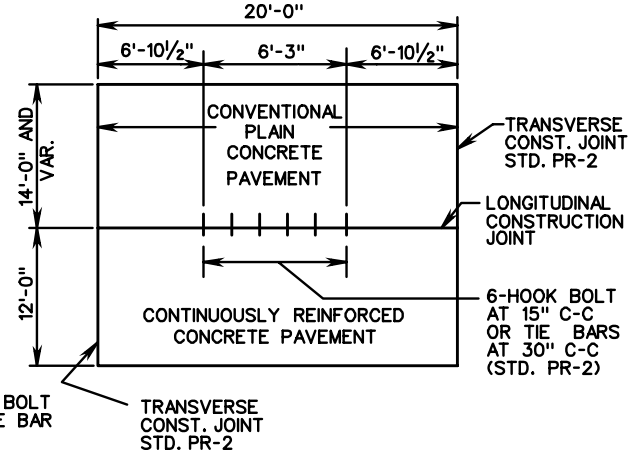

PLAN-RAMP & MAIN LINE
CONNECTION

SPECIFICATION REFERENCE

316

11" THICK CONTINUOUSLY REINFORCED CONC. PAVE.

(14 FOOT TRAVEL LANE)

VIRGINIA DEPARTMENT OF TRANSPORTATION

VDOT

ROAD AND BRIDGE STANDARDS

REVISION DATE

SHEET 1 OF 3

301.19

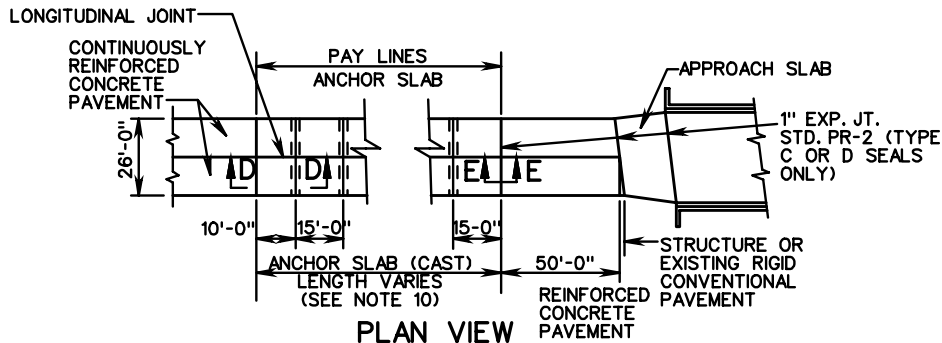

PLAN VIEW ANCHOR SLAB TYPE I

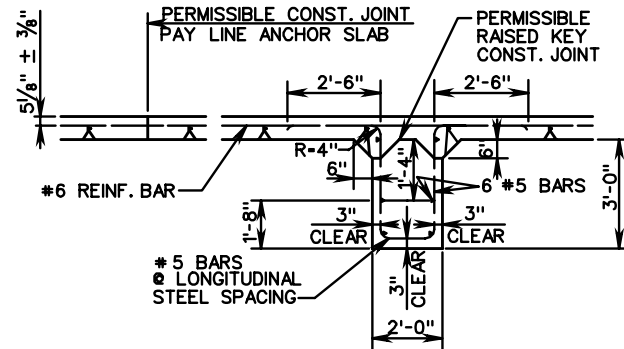

SECTION D-D

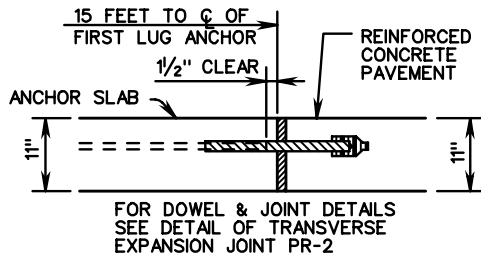

SECTION E-E ANCHOR SLAB TYPE I

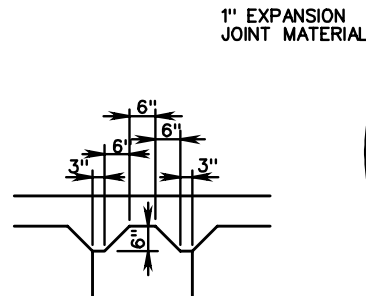

DETAIL-RAISED KEY CONSTRUCTION JOINT

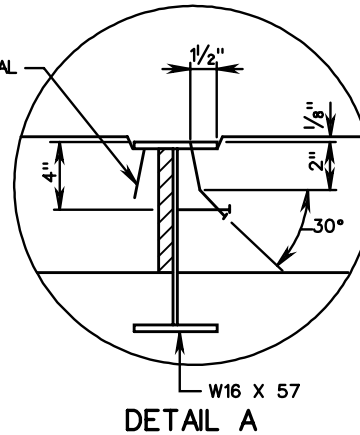

DETAIL A

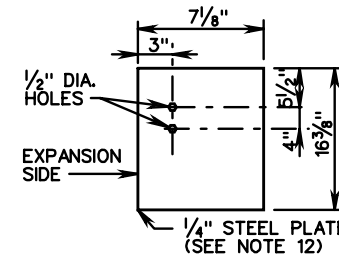

ANCHOR SLAB TYPE II END PLATE DETAIL

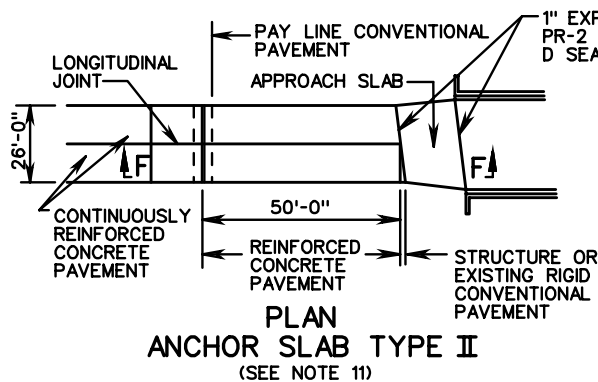

PLAN ANCHOR SLAB TYPE II (SEE NOTE 11)

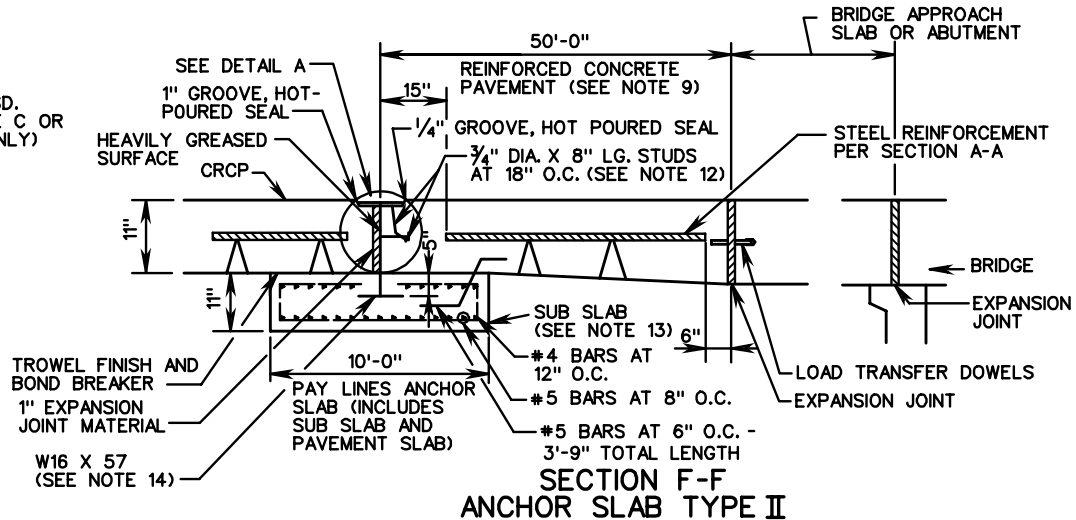

SECTION F-F ANCHOR SLAB TYPE II

SEE SHEET 3 OF 3 FOR NOTES



ROAD AND BRIDGE STANDARDS

11" THICK CONTINUOUSLY REINFORCED CONC. PAVE.
(14 FOOT TRAVEL LANE)

SPECIFICATION REFERENCE

SHEET 2 OF 3

REVISION DATE

VIRGINIA DEPARTMENT OF TRANSPORTATION

301.20

316

NOTES:

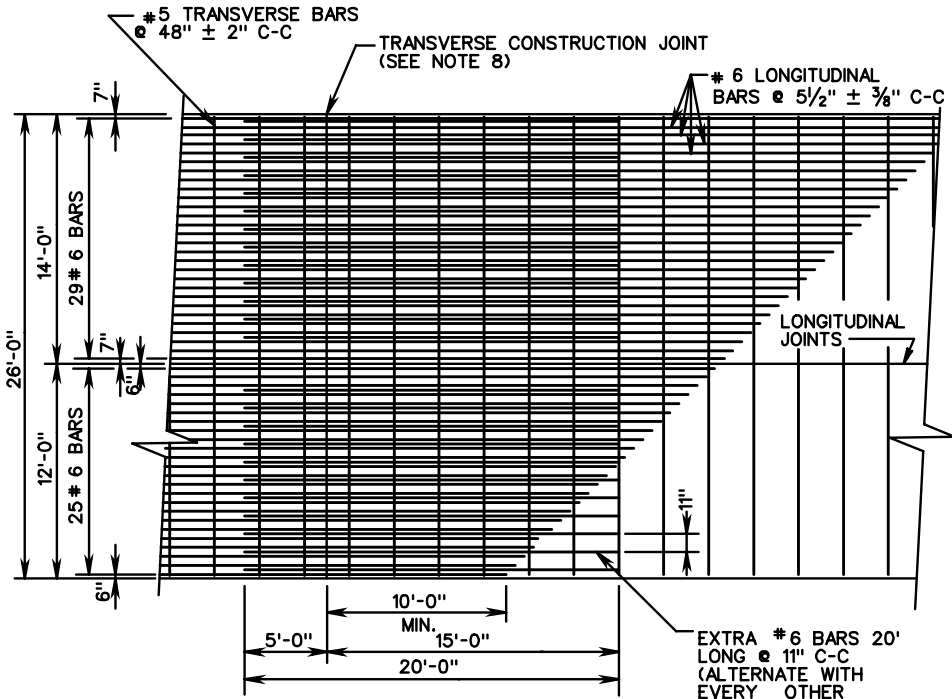

**PLAN VIEW
LEAVE OUT JOINT
STEEL BAR REINFORCEMENT ONLY**

1. HOOK BOLTS OR TIE BARS ARE TO BE PLACED IN THE SAME HORIZONTAL PLANE AS THE #5 TRANSVERSE BARS. WHERE NECESSARY, ADJUST THE LOCATION OF THE HOOK BOLTS OR TIE BARS TO A 2 1/2" MINIMUM CLEARANCE BETWEEN HOOK BOLTS OR TIE BARS AND TRANSVERSE BARS.
2. TRANSVERSE CONSTRUCTION JOINT BARS ARE TO BE PLACED IN THE SAME HORIZONTAL PLANE AS THE #6 LONGITUDINAL BARS.
3. #6 LONGITUDINAL BARS ARE TO BE LAPPED AND TIED IN THE SAME HORIZONTAL PLANE.
4. FOR THE 38 FOOT WIDTH PAVEMENT USE SINGLE 12 FOOT LANES WITH TWO LONGITUDINAL CONSTRUCTION JOINTS OR 12 FOOT AND 14 FOOT LANES WITH ONE LONGITUDINAL CONSTRUCTION JOINT AND ONE SAW CUT OR TAPE INSERT LONGITUDINAL JOINT. TRANSVERSE BARS SHALL NOT EXTEND THROUGH LONGITUDINAL CONSTRUCTION JOINTS, BUT SHALL EXTEND FULL LENGTH (25'-6") FOR SAW CUT OR TAPE INSERT LONGITUDINAL JOINT.
5. SMOOTH SURFACE TO BE STEEL TROWELED 8" IN FROM EDGE OF PAVEMENT EVERY 500 FT., AND THE STATION NUMBER STAMPED INTO IT AS SHOWN BELOW. THE DATE IS TO BE SHOWN IN A SIMILAR MANNER AT THE BEGINNING OF EACH DAYS POUR. BOTH OUTSIDE EDGES OF DIVIDED HIGHWAY ARE TO BE STAMPED. ONE EDGE OF UNDIVIDED HIGHWAY WHERE FEASIBLE (TRAVEL LANE).
6. DOUBLE LAP REQUIREMENT (40") AND THE EXTRA BAR METHOD APPLY ONLY TO LAPS FALLING WITHIN AN AREA OF 10' BEYOND THE CONSTRUCTION JOINT.
7. CONCRETE FOR LUG ANCHORS SHALL BE POURED AGAINST COMPACTED SUBGRADE. CONCRETE FOR LUGS AND ANCHOR SLAB MAY BE POURED MONOLITHICALLY OR POURED USING RAISED KEY CONSTRUCTION JOINT METHOD. ADEQUATE CONSOLIDATION OF CONCRETE IN LUGS WILL BE OBTAINED WITHOUT DISPLACING LONGITUDINAL CONTINUOUS STEEL, BY THE USE OF INTERNAL VIBRATION. WHEN LESS THAN FULL WIDTH LUG AND PAVEMENT SLAB IS PLACED, THE #5 TRANSVERSE STEEL IN THE LUGS SHALL BE EXTENDED, LAPPED AND SPLICED AT LEAST 25 DIAMETERS.
8. LONGITUDINAL STEEL TO CONTINUE THROUGH JOINT. EXTRA # 6 BARS 20' LONG SHALL BE SPACED AT 13 1/2" C-C.
9. CONCRETE SHOULD BE ADEQUATELY VIBRATED UNDER BEAM FLANGE TO ELIMINATE HONEYCOMBS.
10. IN CONDITIONS OF SOFT CLAY UNDERLYING SOILS (AASHTO SOIL CLASSIFICATION OF GROUP A-4, A-5, A-6, OR A-7) INCLUSIVE OF SUBGROUPS (PER AASHTO MATERIALS SPECIFICATIONS M 145), AN ANCHOR SLAB TYPE I UTILIZING 5 ANCHOR LUGS (ANCHOR SLAB LENGTH = 85') OR AN ANCHOR SLAB TYPE II SHALL BE USED. REINFORCEMENT STEEL SIZE AND SPACING WILL BE THE SAME AS THE CONTINUOUS CONCRETE PAVEMENT.

IN CONDITIONS OF GRANULAR UNDERLYING SOILS ONLY (AASHTO SOIL CLASSIFICATION OF GROUP A-1, A-2, OR A-3) INCLUSIVE OF SUBGROUPS (PER AASHTO MATERIALS SPECIFICATIONS M 145), AN ANCHOR SLAB TYPE I UTILIZING 3 ANCHOR LUGS (ANCHOR SLAB LENGTH = 55') OR AN ANCHOR SLAB TYPE II MAY BE USED. REINFORCEMENT STEEL SIZE AND SPACING WILL BE THE SAME AS THE CONTINUOUS CONCRETE PAVEMENT.
11. WELD STEEL END PLATE TO BOTH ENDS OF WF BEAM TO SEAL ENDS. WELD SHEAR CONNECTORS TO WEB AND FLANGE OF WF BEAM.
12. 2 INCH MINIMUM CONCRETE COVER FOR STEEL IN SUB-SLABS.
13. WIDE FLANGE BEAM TO BE TREATED WITH CORROSION INHIBITOR PER SECTION 407 OF THE ROAD AND BRIDGE SPECIFICATIONS.
14. ALL REINFORCED BARS SHALL BE GRADE 60 STEEL.
15. THE USE OF TUBE FEEDING TO PLACE REINFORCEMENT IN PLASTIC CONCRETE WILL NOT BE ALLOWED.

SPECIFICATION REFERENCE

316

**11" THICK CONTINUOUSLY REINFORCED CONC. PAVE.
(14 FOOT TRAVEL LANE)**

VIRGINIA DEPARTMENT OF TRANSPORTATION



ROAD AND BRIDGE STANDARDS

REVISION DATE

SHEET 3 OF 3

301.21

PR-8

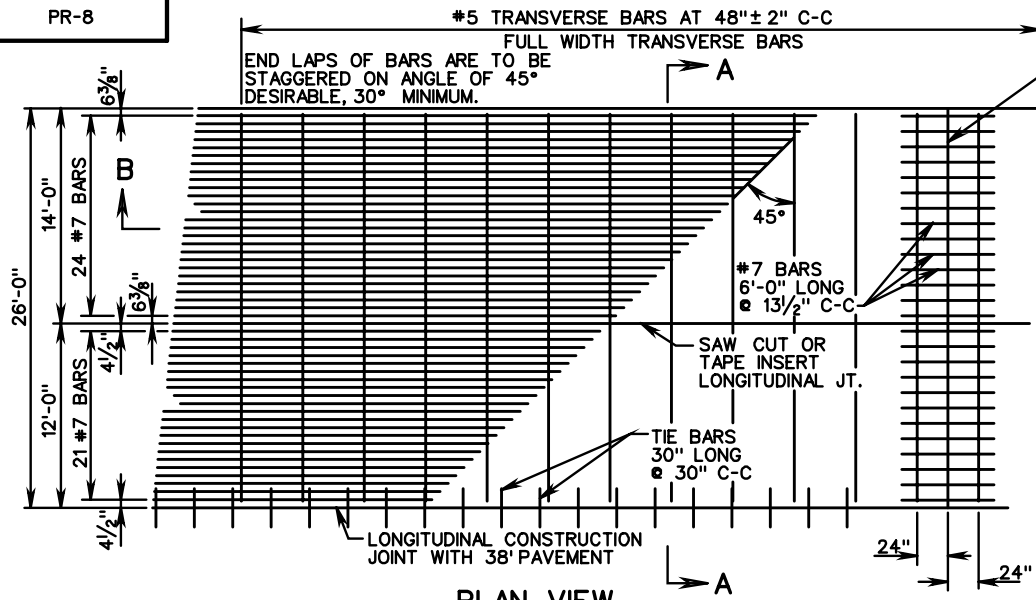

PLAN VIEW
CONTINUOUSLY REINFORCED CONCRETE PAVEMENT

TRANSVERSE CONSTRUCTION JOINT. LONGITUDINAL STEEL TO CONTINUE THROUGH JOINT

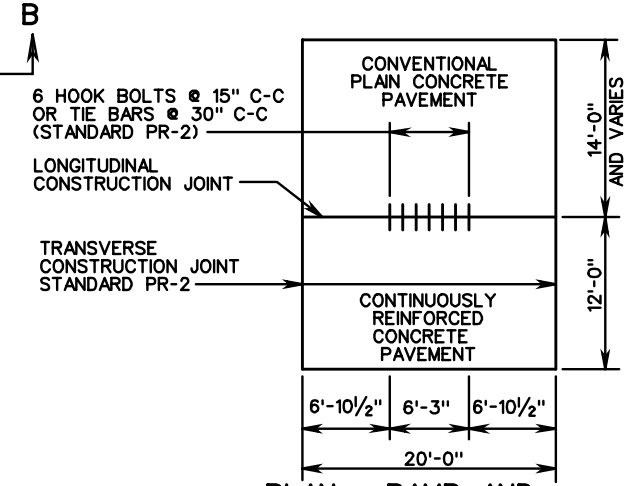

PLAN - RAMP AND MAIN LINE CONNECTION

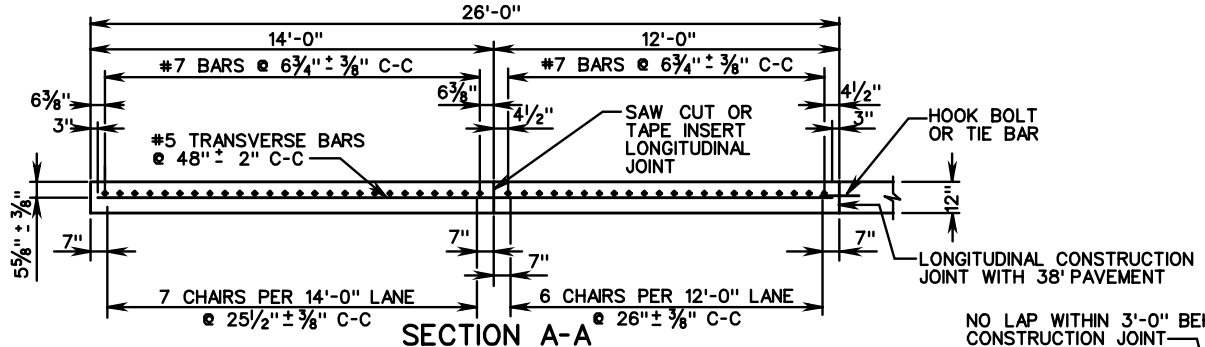

SECTION A-A

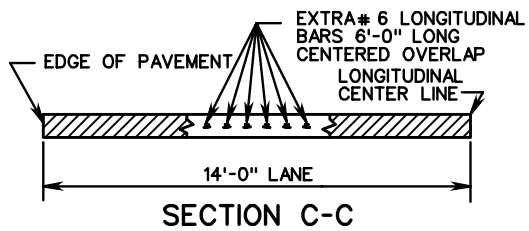

SECTION C-C

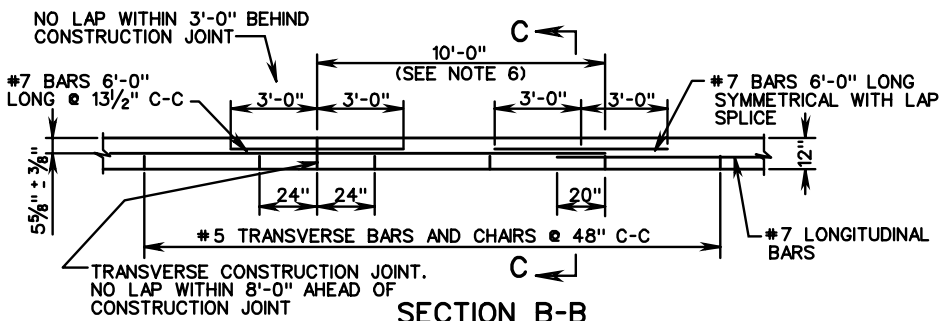

SECTION B-B
EXTRA BAR METHOD

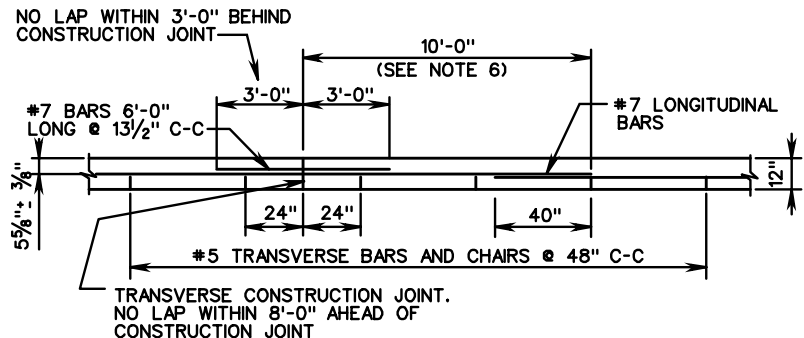

SECTION B-B
DOUBLE LAP METHOD

SEE SHEET 3 OF 3 FOR NOTES

VDOT	
ROAD AND BRIDGE STANDARDS	
SHEET 1 OF 3	REVISION DATE
301.22	

12" THICK CONTINUOUSLY REINFORCED CONC. PAVE. (14' TRAVEL LANE)

VIRGINIA DEPARTMENT OF TRANSPORTATION

SPECIFICATION REFERENCE
316

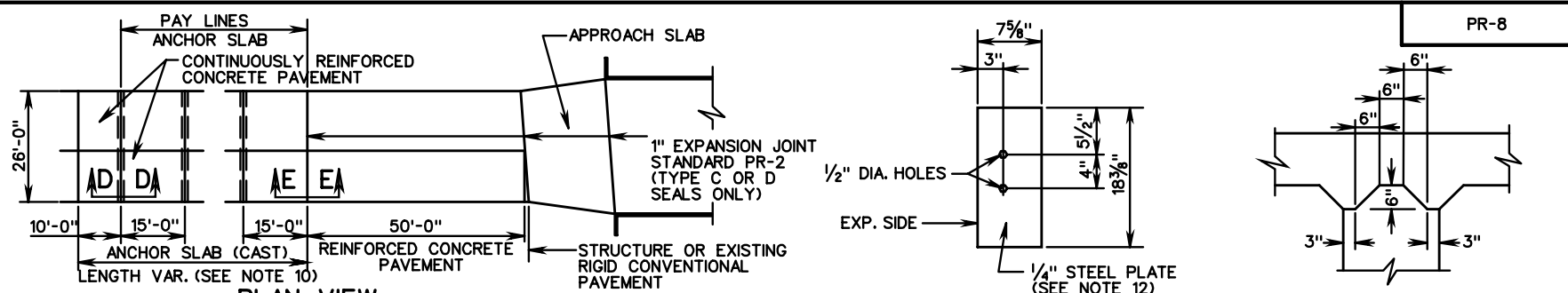

PLAN VIEW ANCHOR SLAB TYPE I

ANCHOR SLAB TYPE II END PLATE DETAIL

DETAIL A RAISED KEY CONSTRUCTION JOINT

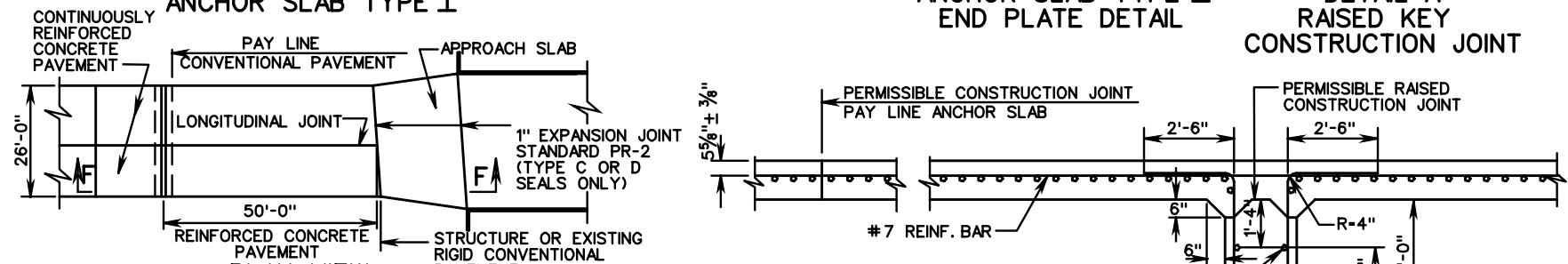

PLAN VIEW ANCHOR SLAB TYPE II

SECTION D-D

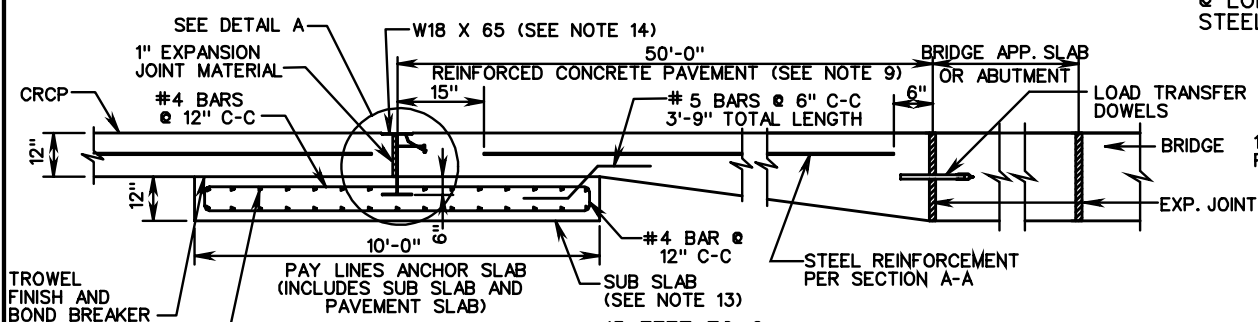

SECTION F-F ANCHOR SLAB TYPE II (SEE NOTE 11)

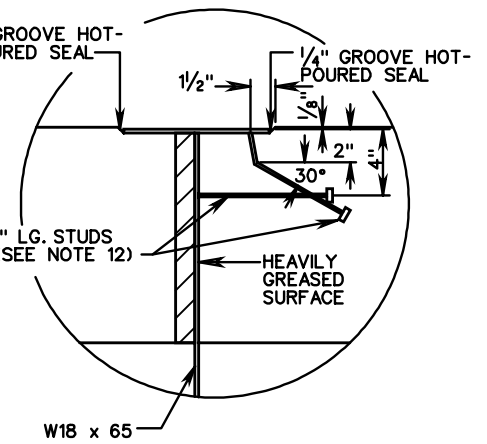

DETAIL A

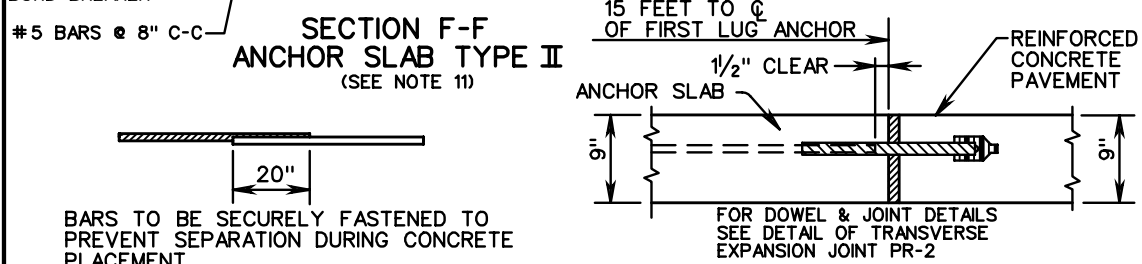

SECTION E-E ANCHOR SLAB TYPE I

BARS TO BE SECURELY FASTENED TO PREVENT SEPARATION DURING CONCRETE PLACEMENT.

TYPICAL LONGITUDINAL LAP

SEE SHEET 3 OF 3 FOR NOTES

SPECIFICATION REFERENCE	12" THICK CONTINUOUSLY REINFORCED CONC PAVE. (14' TRAVEL LANE)	VDOT ROAD AND BRIDGE STANDARDS	
316		REVISION DATE	SHEET 2 OF 3
VIRGINIA DEPARTMENT OF TRANSPORTATION		301.23	

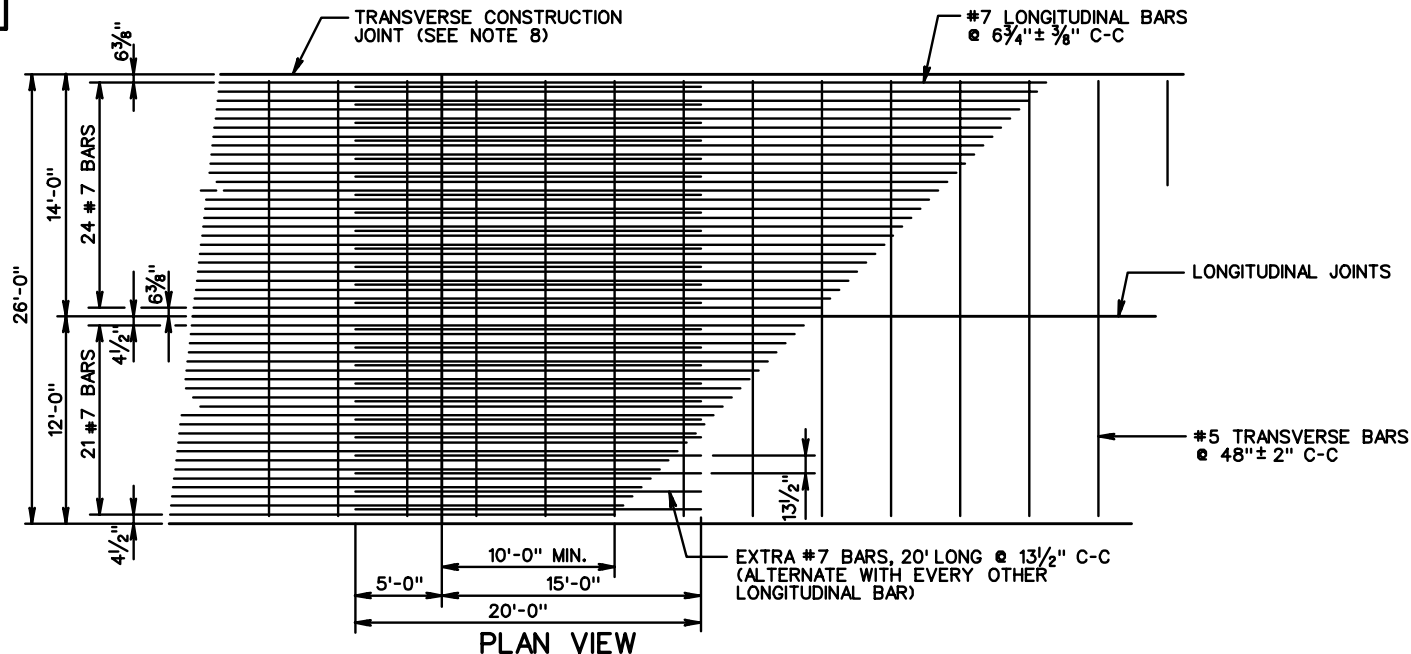

LEAVE OUT JOINT STEEL BAR REINFORCEMENT ONLY

NOTES:

- HOOK BOLTS OR TIE BARS ARE TO BE PLACED IN THE SAME HORIZONTAL PLANE AS #5 TRANSVERSE BARS. WHERE NECESSARY, ADJUST THE LOCATION OF THE HOOK BOLTS OR TIE BARS TO A 2 1/2" MIN. CLEARANCE BETWEEN HOOK BOLTS OR TIE BARS AND TRANSVERSE BARS.
- TRANSVERSE CONSTRUCTION JOINT BARS ARE TO BE PLACED IN THE SAME HORIZONTAL PLANE AS THE #7 LONGITUDINAL BARS.
- #7 LONGITUDINAL BARS ARE TO BE LAPPED AND TIED IN THE SAME HORIZONTAL PLANE.
- FOR THE 38 FOOT WIDTH PAVEMENT USE SINGLE 12 FOOT LANES WITH TWO LONGITUDINAL CONSTRUCTION JOINTS OR 12 FOOT AND 14 FOOT LANES WITH ONE LONGITUDINAL CONSTRUCTION JOINT AND ONE SAW CUT OR TAPE INSERT LONGITUDINAL JOINT. TRANSVERSE BARS SHALL NOT EXTEND THROUGH LONGITUDINAL CONSTRUCTION JOINTS, BUT SHALL EXTEND FULL LENGTH (25'-6") FOR SAW CUT OR TAPE INSERT LONGITUDINAL JOINT.
- SMOOTH SURFACE TO BE STEEL TROWELED 8" FROM EDGE OF PAVEMENT EVERY 500 FT. AND THE STATION NUMBER STAMPED INTO IT AS SHOWN BELOW. THE DATE IS TO BE SHOWN IN A SIMILAR MANNER AT THE BEGINNING OF EACH DAYS POUR. BOTH OUTSIDE EDGES OF DIVIDED HIGHWAY ARE TO BE STAMPED. ONE EDGE OF UNDIVIDED HIGHWAY WHERE FEASIBLE (TRAVEL LANE).

255

↓
- DOUBLE LAP REQUIREMENT (40") AND THE EXTRA BAR METHOD APPLY ONLY TO LAPS FALLING WITHIN AN AREA OF 10' BEYOND THE CONSTRUCTION JOINT.
- CONCRETE FOR LUG ANCHORS SHALL BE POURED AGAINST COMPACTED SUBGRADE. CONCRETE FOR LUGS AND ANCHOR SLAB MAY BE POURED MONOLITHICALLY OR USING RAISED KEY CONSTRUCTION JOINT METHOD. ADEQUATE CONSOLIDATION OF CONCRETE IN LUGS WILL BE OBTAINED WITHOUT DISPLACING LONGITUDINAL CONTINUOUS STEEL, BY THE USE OF INTERNAL VIBRATION. WHEN LESS THAN FULL WIDTH LUG AND PAVEMENT SLAB IS PLACED, THE #5 TRANSVERSE STEEL IN THE LUGS SHALL BE EXTENDED, LAPPED AND SPLICED AT LEAST 25 DIAMETERS.
- LONGITUDINAL STEEL TO CONTINUE THROUGH JOINT. EXTRA # 6 BARS 20' LONG SHALL BE SPACED AT 13 1/2" C-C.
- CONCRETE SHOULD BE ADEQUATELY VIBRATED UNDER BEAM FLANGE TO ELIMINATE HONEYCOMBS.
- IN CONDITIONS OF SOFT CLAY UNDERLYING SOILS (AASHTO SOIL CLASSIFICATION OF GROUP A-4, A-5, A-6, OR A-7) INCLUSIVE OF SUBGROUPS (PER AASHTO MATERIALS SPECIFICATIONS M 145), AN ANCHOR SLAB TYPE I UTILIZING 5 ANCHOR LUGS (ANCHOR SLAB LENGTH = 85') OR AN ANCHOR SLAB TYPE II SHALL BE USED. REINFORCEMENT STEEL SIZE AND SPACING WILL BE THE SAME AS THE CONTINUOUS CONCRETE PAVEMENT.
- IN CONDITIONS OF GRANULAR UNDERLYING SOILS ONLY (AASHTO SOIL CLASSIFICATION OF GROUP A-1, A-2, OR A-3) INCLUSIVE OF SUBGROUPS (PER AASHTO MATERIALS SPECIFICATIONS M 145), AN ANCHOR SLAB TYPE I UTILIZING 3 ANCHOR LUGS (ANCHOR SLAB LENGTH = 55') OR AN ANCHOR SLAB TYPE II MAY BE USED. REINFORCEMENT STEEL SIZE AND SPACING WILL BE THE SAME AS THE CONTINUOUS CONCRETE PAVEMENT.
- WELD STEEL END PLATE TO BOTH ENDS OF WF BEAM TO SEAL ENDS. WELD SHEAR CONNECTORS TO WEB AND FLANGE OF WF BEAM.
- 2 INCH MINIMUM CONCRETE COVER FOR STEEL IN SUB-SLABS.
- WIDE FLANGE BEAM TO BE TREATED WITH CORROSION INHIBITOR PER SECTION 407 OF THE ROAD AND BRIDGE SPECIFICATIONS.
- ALL REINFORCED BARS SHALL BE GRADE 60 STEEL.
- THE USE OF TUBE FEEDING TO PLACE REINFORCEMENT IN PLASTIC CONCRETE WILL NOT BE ALLOWED.

VDOT

ROAD AND BRIDGE STANDARDS

12" THICK CONTINUOUSLY REINFORCED CONC. PAVE. (14' TRAVEL LANE)

SPECIFICATION
REFERENCE

SHEET 3 OF 3

REVISION DATE

301.24

VIRGINIA DEPARTMENT OF TRANSPORTATION

316

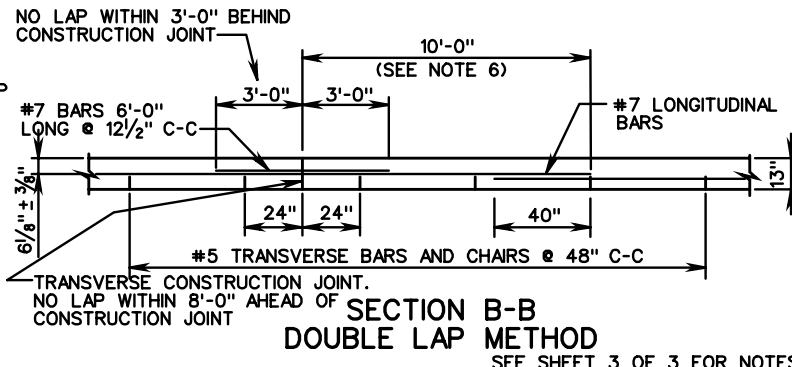
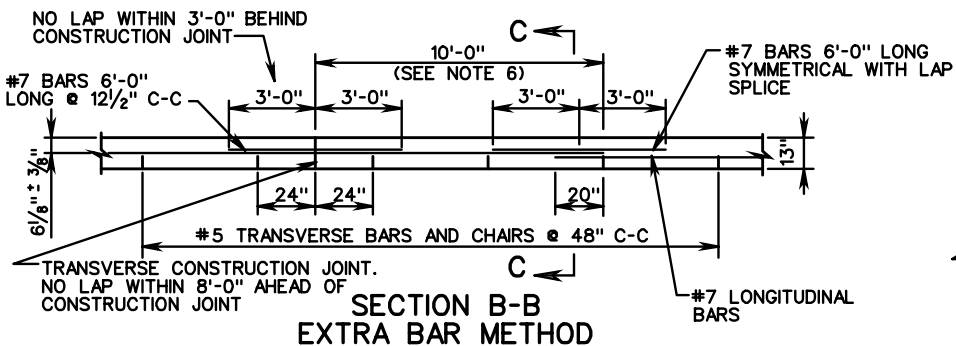
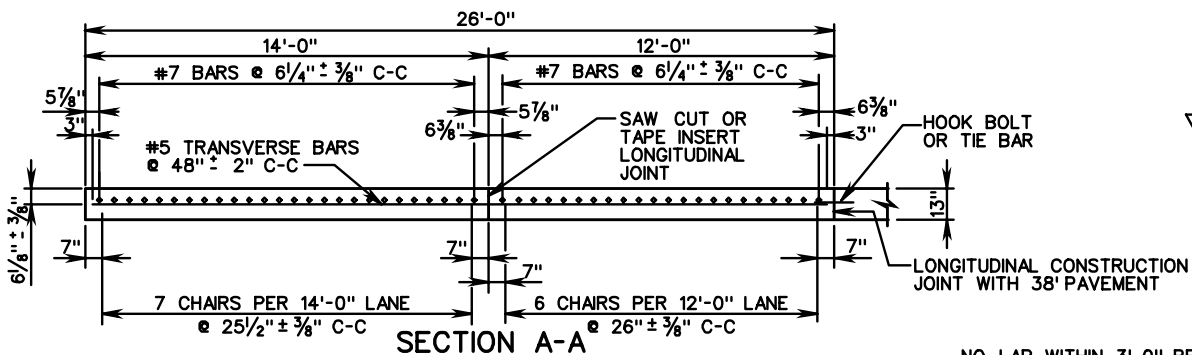
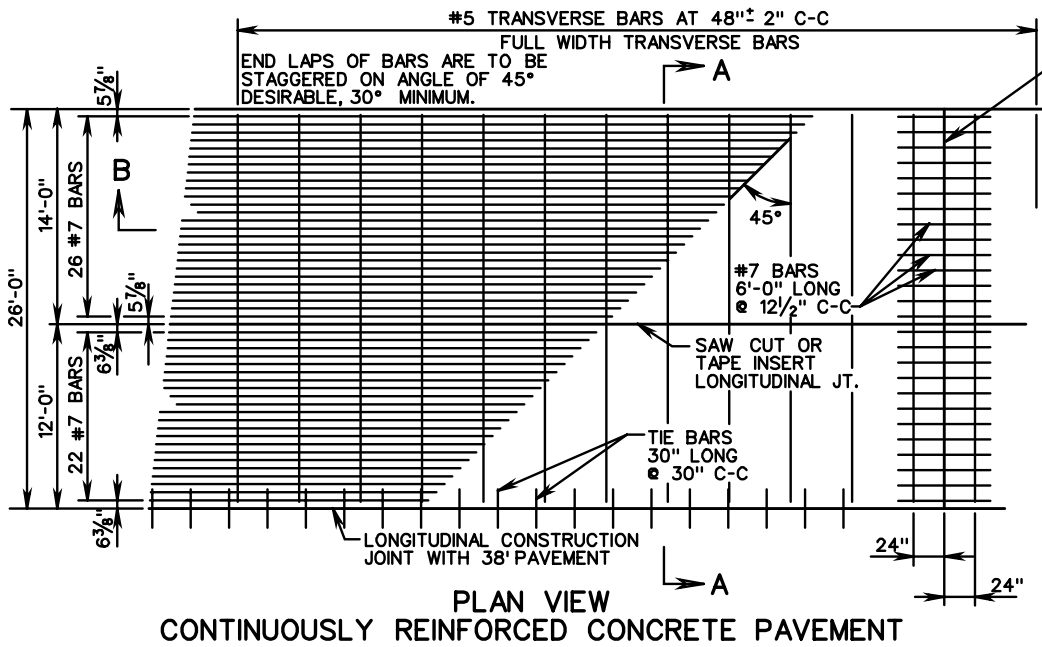

SEE SHEET 3 OF 3 FOR NOTES

SPECIFICATION REFERENCE

13" THICK CONTINUOUSLY REINFORCED CONC. PAVE.
(14' TRAVEL LANE)

316

VIRGINIA DEPARTMENT OF TRANSPORTATION

VDOT

ROAD AND BRIDGE STANDARDS

REVISION DATE

SHEET 1 OF 3

301.25

PR-9

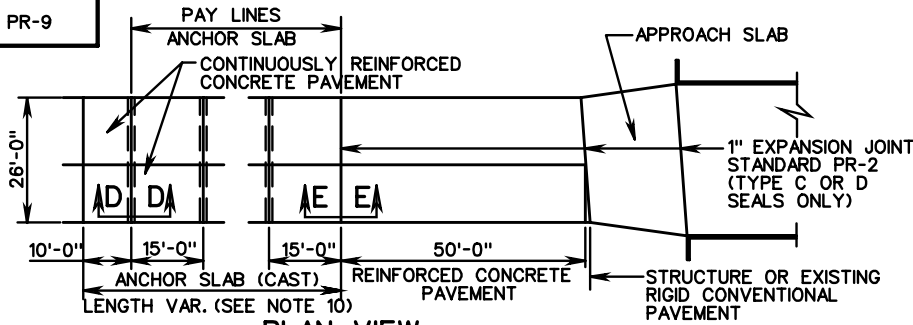

PLAN VIEW ANCHOR SLAB TYPE T

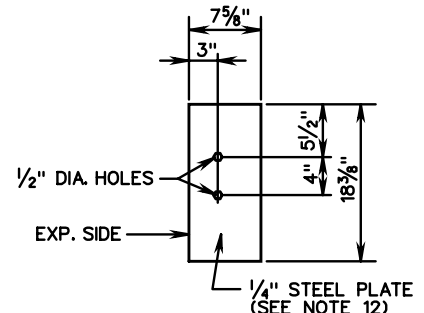

ANCHOR SLAB TYPE II END PLATE DETAIL

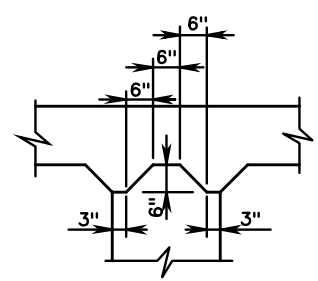

DETAIL A RAISED KEY CONSTRUCTION JOINT

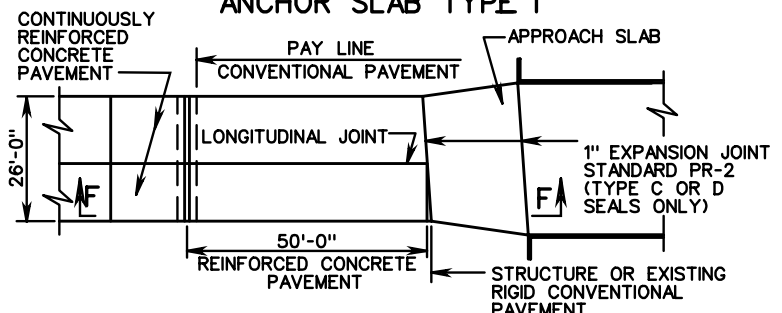

PLAN VIEW ANCHOR SLAB TYPE II

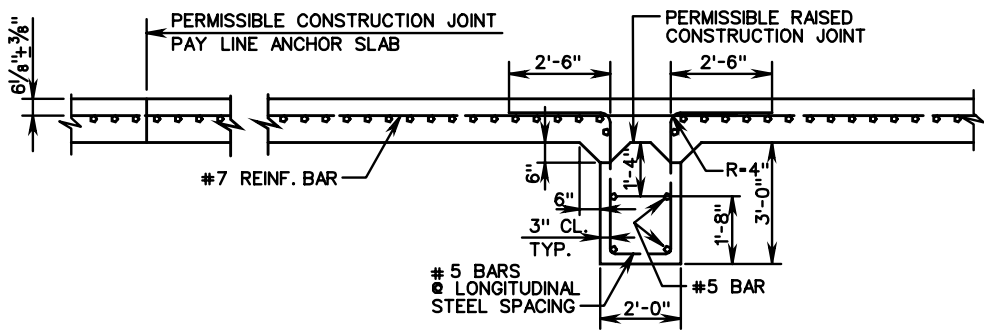

SECTION D-D

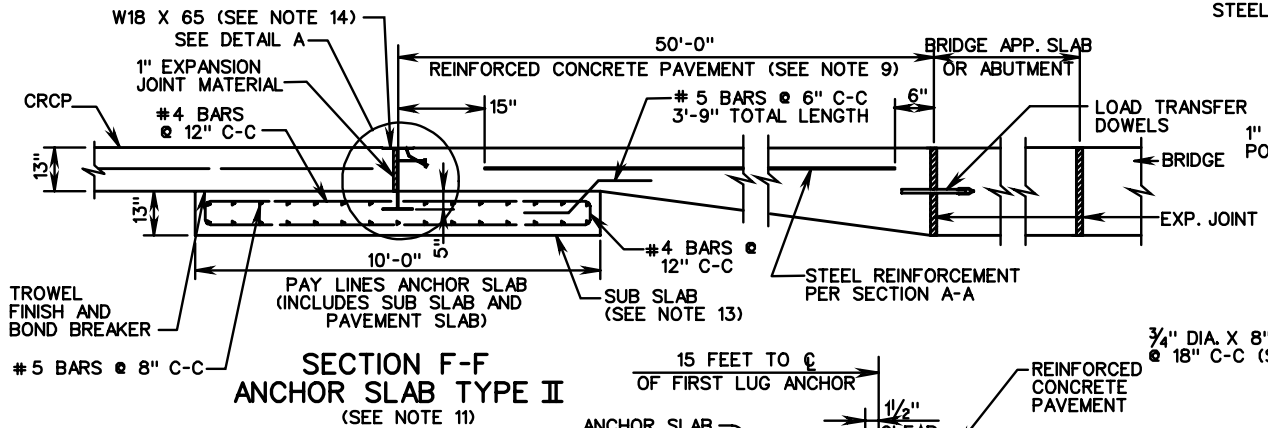

SECTION F-F ANCHOR SLAB TYPE II (SEE NOTE 11)

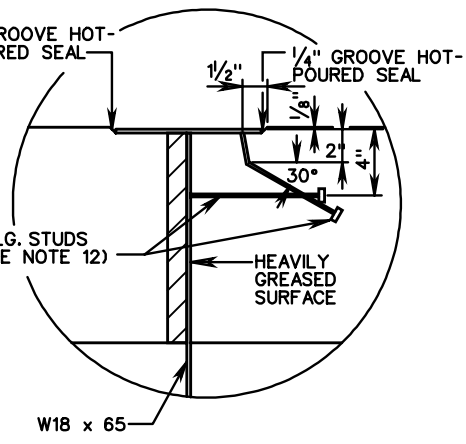

DETAIL A

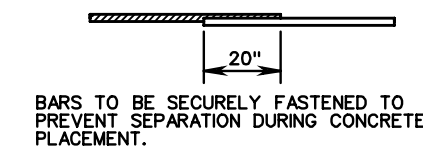

TYPICAL LONGITUDINAL LAP

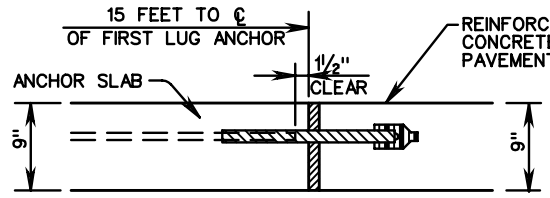

SECTION E-E ANCHOR SLAB TYPE I

FOR DOWEL & JOINT DETAILS SEE DETAIL OF TRANSVERSE EXPANSION JOINT PR-2

SEE SHEET 3 OF 3 FOR NOTES

VDOT	
ROAD AND BRIDGE STANDARDS	
SHEET 2 OF 3	REVISION DATE
301.26	

13" THICK CONTINUOUSLY REINFORCED CONC. PAVE.
(14' TRAVEL LANE)

SPECIFICATION REFERENCE
316

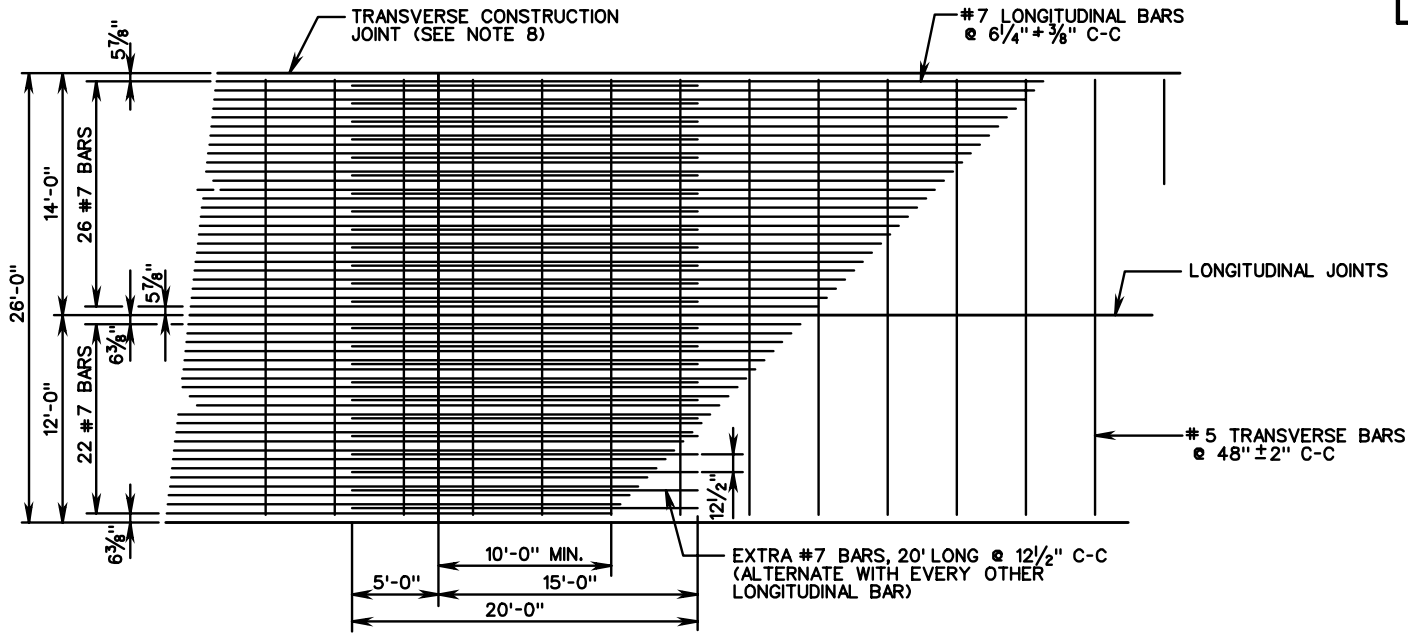

PLAN VIEW
LEAVE OUT JOINT STEEL BAR REINFORCEMENT ONLY

NOTES:

- HOOK BOLTS OR TIE BARS ARE TO BE PLACED IN THE SAME HORIZONTAL PLANE AS #5 TRANSVERSE BARS. WHERE NECESSARY, ADJUST THE LOCATION OF THE HOOK BOLTS OR TIE BARS TO A 2 1/2" MIN. CLEARANCE BETWEEN HOOK BOLTS OR TIE BARS AND TRANSVERSE BARS.
- TRANSVERSE CONSTRUCTION JOINT BARS ARE TO BE PLACED IN THE SAME HORIZONTAL PLANE AS THE #7 LONGITUDINAL BARS.
- #7 LONGITUDINAL BARS ARE TO BE LAPPED AND TIED IN THE SAME HORIZONTAL PLANE.
- FOR THE 38 FOOT WIDTH PAVEMENT USE SINGLE 12 FOOT LANES WITH TWO LONGITUDINAL CONSTRUCTION JOINTS OR 12 FOOT AND 14 FOOT LANES WITH ONE LONGITUDINAL CONSTRUCTION JOINT AND ONE SAW CUT OR TAPE INSERT LONGITUDINAL JOINT. TRANSVERSE BARS SHALL NOT EXTEND THROUGH LONGITUDINAL CONSTRUCTION JOINTS, BUT SHALL EXTEND FULL LENGTH (25'-6") FOR SAW CUT OR TAPE INSERT LONGITUDINAL JOINT.
- SMOOTH SURFACE TO BE STEEL TROWELED 8" FROM EDGE OF PAVEMENT EVERY 500 FT. AND THE STATION NUMBER STAMPED INTO IT AS SHOWN BELOW. THE DATE IS TO BE SHOWN IN A SIMILAR MANNER AT THE BEGINNING OF EACH DAYS POUR. BOTH OUTSIDE EDGES OF DIVIDED HIGHWAY ARE TO BE STAMPED. ONE EDGE OF UNDIVIDED HIGHWAY WHERE FEASIBLE (TRAVEL LANE).
- DOUBLE LAP REQUIREMENT (40") AND THE EXTRA BAR METHOD APPLY ONLY TO LAPS FALLING WITHIN AN AREA OF 10' BEYOND THE CONSTRUCTION JOINT.
- CONCRETE FOR LUG ANCHORS SHALL BE POURED AGAINST COMPACTED SUBGRADE. CONCRETE FOR LUGS AND ANCHOR SLAB MAY BE POURED MONOLITHICALLY OR USING RAISED KEY CONSTRUCTION JOINT METHOD. ADEQUATE CONSOLIDATION OF CONCRETE IN LUGS WILL BE OBTAINED WITHOUT DISPLACING LONGITUDINAL CONTINUOUS STEEL, BY THE USE OF INTERNAL VIBRATION. WHEN LESS THAN FULL WIDTH LUG AND PAVEMENT SLAB IS PLACED, THE #5 TRANSVERSE STEEL IN THE LUGS SHALL BE EXTENDED, LAPPED AND SPLICED AT LEAST 25 DIAMETERS.
- LONGITUDINAL STEEL TO CONTINUE THROUGH JOINT. EXTRA #6 BARS 20' LONG SHALL BE SPACED AT 13 1/2" C-C.
- CONCRETE SHOULD BE ADEQUATELY VIBRATED UNDER BEAM FLANGE TO ELIMINATE HONEYCOMBS.
- IN CONDITIONS OF SOFT CLAY UNDERLYING SOILS (AASHTO SOIL CLASSIFICATION OF GROUP A-4, A-5, A-6, OR A-7) INCLUSIVE OF SUBGROUPS (PER AASHTO MATERIALS SPECIFICATIONS M 145), AN ANCHOR SLAB TYPE I UTILIZING 5 ANCHOR LUGS (ANCHOR SLAB LENGTH = 85') OR AN ANCHOR SLAB TYPE II SHALL BE USED. REINFORCEMENT STEEL SIZE AND SPACING WILL BE THE SAME AS THE CONTINUOUS CONCRETE PAVEMENT.

IN CONDITIONS OF GRANULAR UNDERLYING SOILS ONLY (AASHTO SOIL CLASSIFICATION OF GROUP A-1, A-2, OR A-3) INCLUSIVE OF SUBGROUPS (PER AASHTO MATERIALS SPECIFICATIONS M 145), AN ANCHOR SLAB TYPE I UTILIZING 3 ANCHOR LUGS (ANCHOR SLAB LENGTH = 55') OR AN ANCHOR SLAB TYPE II MAY BE USED. REINFORCEMENT STEEL SIZE AND SPACING WILL BE THE SAME AS THE CONTINUOUS CONCRETE PAVEMENT.
- WELD STEEL END PLATE TO BOTH ENDS OF WF BEAM TO SEAL ENDS. WELD SHEAR CONNECTORS TO WEB AND FLANGE OF WF BEAM.
- 2 INCH MINIMUM CONCRETE COVER FOR STEEL IN SUB-SLABS.
- WIDE FLANGE BEAM TO BE TREATED WITH CORROSION INHIBITOR PER SECTION 407 OF THE ROAD AND BRIDGE SPECIFICATIONS.
- ALL REINFORCED BARS SHALL BE GRADE 60 STEEL.
- THE USE OF TUBE FEEDING TO PLACE REINFORCEMENT IN PLASTIC CONCRETE WILL NOT BE ALLOWED.

SPECIFICATION REFERENCE

13" THICK CONTINUOUSLY REINFORCED CONC. PAVE.

VDOT

ROAD AND BRIDGE STANDARDS

316

(14' TRAVEL LANE)

REVISION DATE

SHEET 3 OF 3

VIRGINIA DEPARTMENT OF TRANSPORTATION

301.27

THIS PAGE INTENTIONALLY LEFT BLANK



ROAD AND BRIDGE STANDARDS

SHEET 1 OF 1

REVISION DATE

301.28

VIRGINIA DEPARTMENT OF TRANSPORTATION

SPECIFICATION
REFERENCE

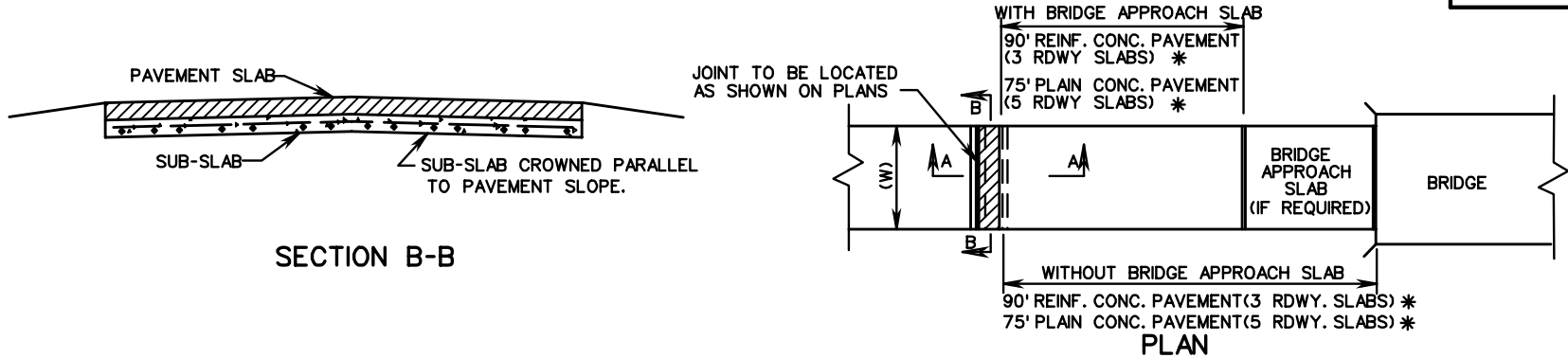

* DENOTES DESIRABLE VALUES, PAVEMENT TYPE (PLAIN OR REINFORCED) TO BE DETERMINED BY THE MATERIALS DIVISION.

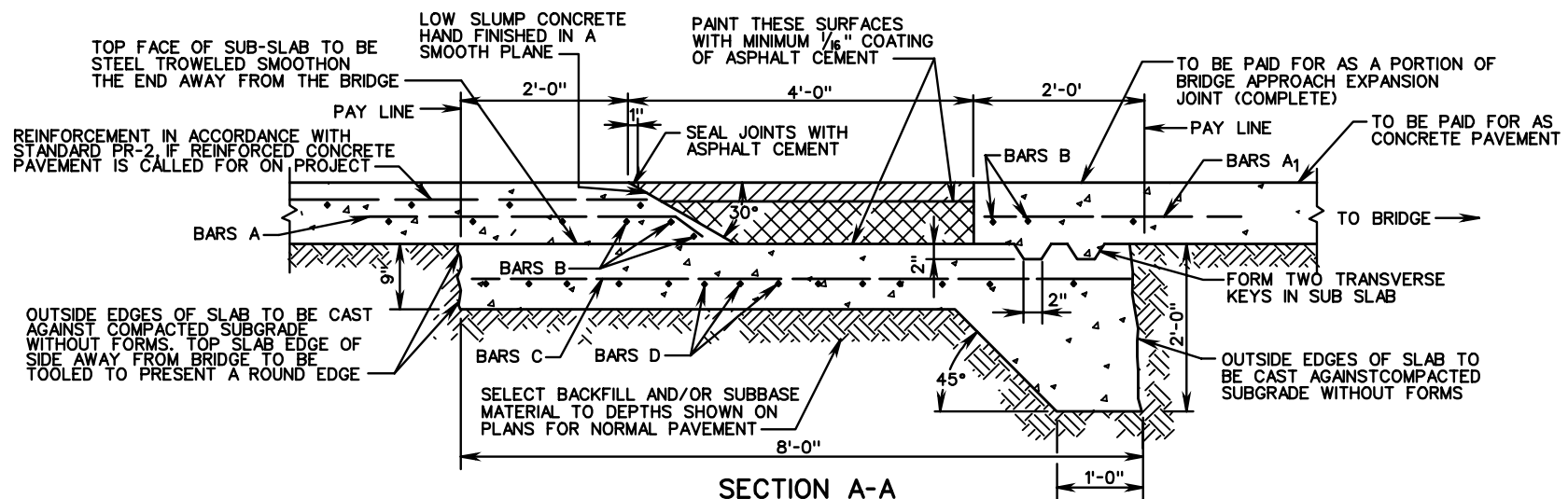

	APPROXIMATE QUANTITIES PER YARD OF TRANSVERSE MEASURE	
	8"	9"
CUBIC YARDS CLASS A3 CONCRETE	0.30	0.30
REINFORCING STEEL LBS.	33.44	33.44
ASPHALT CONCRETE BM-25.0 TONS	0.16	0.18
TONS ASPHALT CONCRETE CONN. SM-9.5A OR D	0.06	0.06
SQ. YARDS CONCRETE PAVEMENT **	0.51	0.52

** BEVELED PORTION OF PAVEMENT SLAB HAS BEEN CONVERTED TO EQUIVALENT DESIGN DEPTH OF MAIN LINE PAVEMENT.

SCHEDULE OF REINFORCING STEEL					
MARK	SIZE	SPACING C-C	LENGTH	NO. REQ'D.	WEIGHT/FT. TRANSVERSE MEASURE LBS.
A	5	12"	4'-0"	(W)	4.172
A ₁	5	12"	3'-0"	(W)	3.129
B	5	6"	W-4"	5	5.215
C	4	6"	7'-8"	(W)(2)	10.240
D	4	6"	W-4"	16	10.688

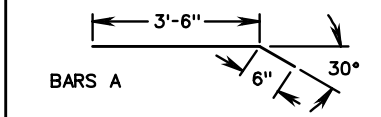

ASPHALT CONCRETE BASE COURSE TYPE BM-25.0
6" WITH 8" PAVEMENT
7" WITH 9" PAVEMENT

2" ASPHALT CONCRETE TYPE SM-9.5A OR D

NOTES:
CONCRETE IN SUBSLAB TO BE CLASS A3.
BARS A, A₁, & B TO BE PLACED AS SHOWN WHETHER PLAIN OR REINFORCED CONCRETE PAVEMENT IS USED.
PORTIONS OF BARS A AND A₁, WHICH ARE OUTSIDE OF THE INDICATED PAY LINES ARE INCLUDED IN PRICE BID FOR COMPLETE JOINT.

SPECIFICATION REFERENCE
316

BRIDGE APPROACH EXPANSION JOINT (FOR WIDENING OR MAINTENANCE OF EXISTING XJ-1 ONLY)

VIRGINIA DEPARTMENT OF TRANSPORTATION

VDOT ROAD AND BRIDGE STANDARDS	
REVISION DATE	SHEET 1 OF 2
302.01	

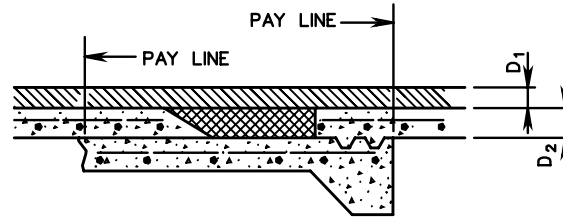

D₁ = DEPTH OF ASPHALT TOP USED ON APPROACHES
 D₂ = DEPTH OF CONCRETE BASE USED ON APPROACHES

VIEW (A)

USED WITH CONCRETE BASE WITH ASPHALT CONCRETE SURFACE

NOTE:

BRIDGE APPROACH EXPANSION JOINT INCLUDING SUB-SLAB IS TO TERMINATE AT EDGE OF THROUGH PAVEMENT.

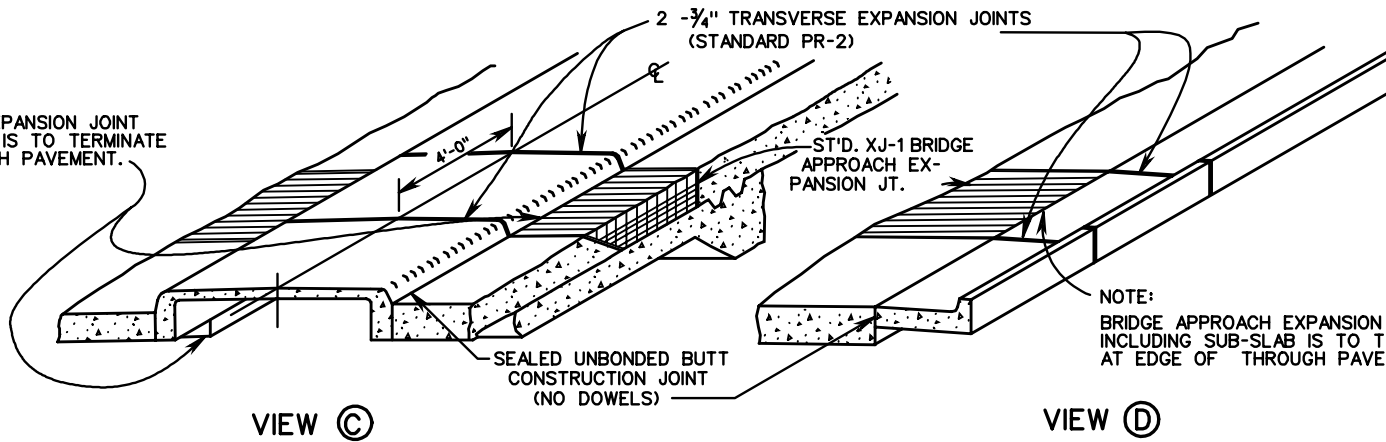

VIEW (C)

USED ADJACENT TO RAISED MEDIAN

VIEW (D)

USED ADJACENT TO CURB OR COMBINATION CURB AND GUTTER

NOTES:

ALL CONSTRUCTION FEATURES TO BE IN ACCORDANCE WITH SHEET 1 OF 2.
 IF CONCRETE PAVEMENT IS USED ADJACENT TO CONCRETE PAVEMENT WITH ASPHALT CONCRETE SURFACE, THE JOINT IS TO CONTINUE ACROSS ENTIRE WIDTH IN ACCORDANCE WITH SHEET 1 OF 2 AND VIEW A.
 IF CONCRETE PAVEMENT IS USED ADJACENT TO FLEXIBLE PAVEMENT THE JOINT IS TO EXTEND THROUGH RIGID PAVEMENT ONLY.



ROAD AND BRIDGE STANDARDS

SHEET 2 OF 2

REVISION DATE

302.02

**BRIDGE APPROACH EXPANSION JOINT
 (INSTALLATION CRITERIA)**

VIRGINIA DEPARTMENT OF TRANSPORTATION

SPECIFICATION REFERENCE

316

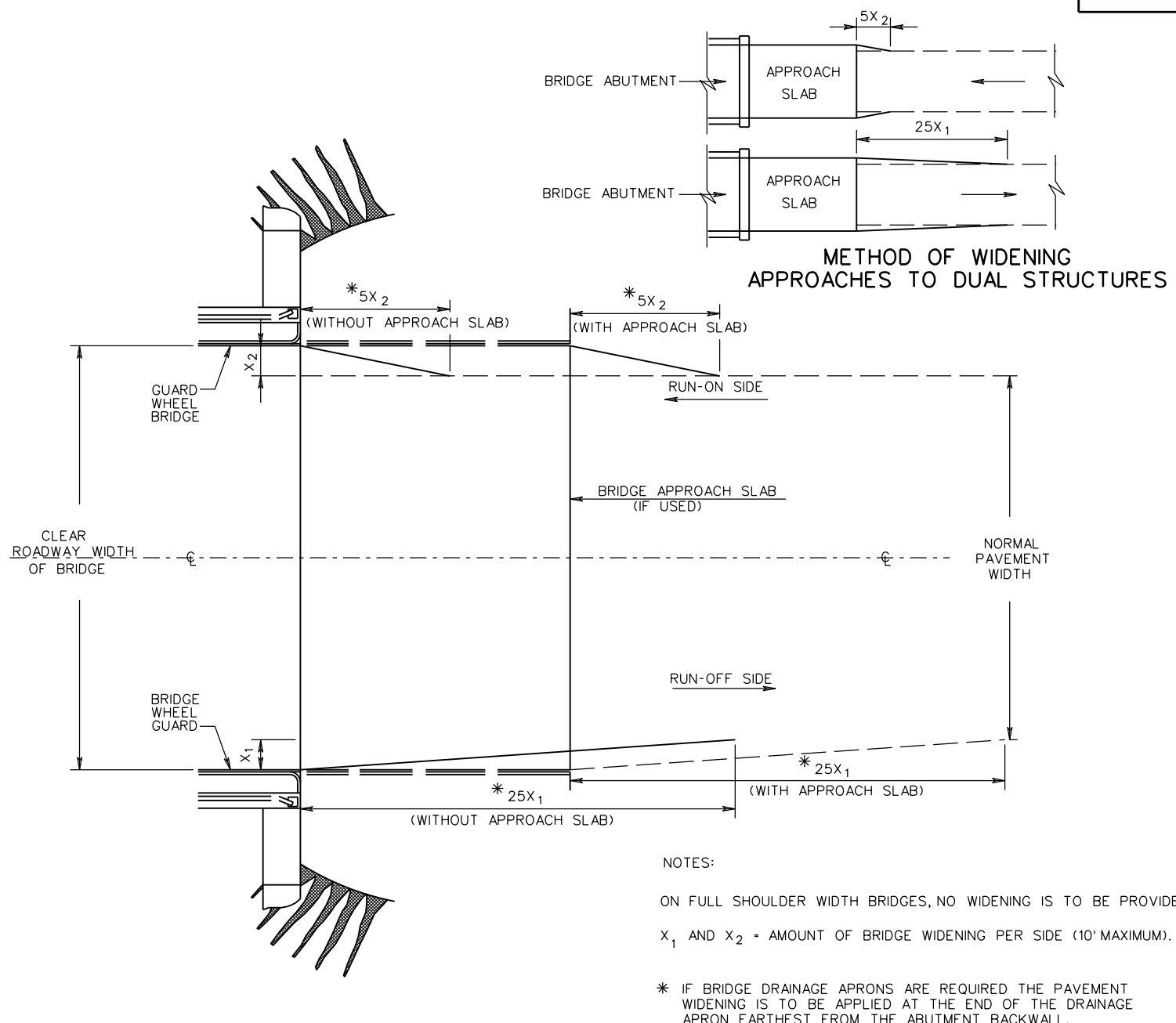

NOTES:

ON FULL SHOULDER WIDTH BRIDGES, NO WIDENING IS TO BE PROVIDED.

X_1 AND X_2 = AMOUNT OF BRIDGE WIDENING PER SIDE (10' MAXIMUM).



* IF BRIDGE DRAINAGE APRONS ARE REQUIRED THE PAVEMENT WIDENING IS TO BE APPLIED AT THE END OF THE DRAINAGE APRON FARTHEST FROM THE ABUTMENT BACKWALL.

THIS DRAWING WAS VOID WITH THE JULY 2013 R&B STANDARDS REVISION

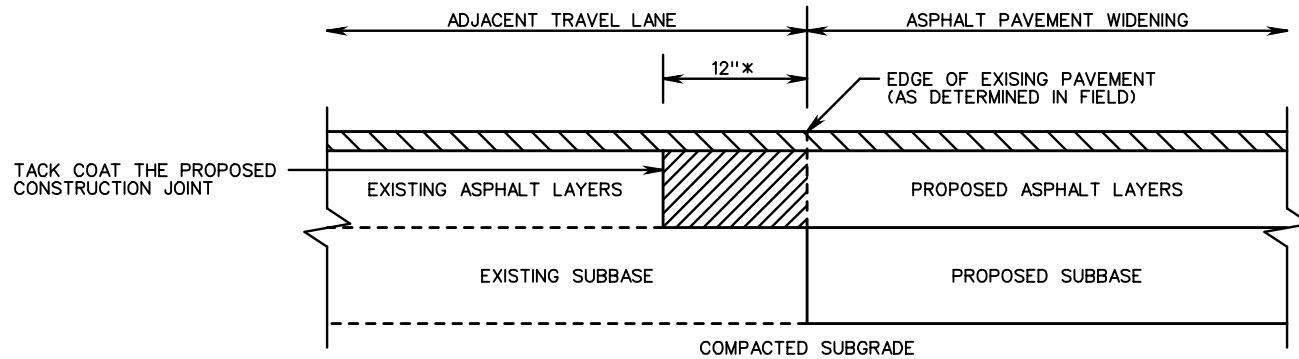
SPECIFICATION REFERENCE NONE	<p style="font-size: 2em; font-weight: bold; opacity: 0.5;">VOID</p> <p style="font-size: 1.5em; font-weight: bold;">METHOD OF WIDENING BRIDGE APPROACH PAVEMENT</p> <p style="font-size: 0.8em;">VIRGINIA DEPARTMENT OF TRANSPORTATION</p>	<p style="font-weight: bold; font-size: 1.2em;">VDOT</p> ROAD AND BRIDGE STANDARDS REVISION DATE 7/12 SHEET 1 OF 1 303.01
---------------------------------	---	--



CONSTRUCTION JOINT DETAIL

-  REMOVE EXISTING ASPHALT LAYERS TO EXISTING SUBBASE AND REPLACE WITH PROPOSED ASPHALT WIDENING LAYERS
-  PROPOSED MINIMUM 1½ INCH THICK ASPHALT SURFACE COURSE (SEE NOTE 5)
- * MINIMUM 12 INCHES, OR GREATER AS NECESSARY TO ABUT THE FULL THICKNESS OF EXISTING ASPHALT LAYERS AS DETERMINED BY CORES (SEE NOTE 3)

NOTES:

1. ASPHALT PAVEMENT WIDENING SHALL HAVE A PAVEMENT DESIGN IN ACCORDANCE WITH CURRENT VDOT PROCEDURES AND BE APPROVED BY THE ENGINEER.
2. THE PAVEMENT DESIGN FOR ASPHALT PAVEMENT WIDENING SHALL MEET OR EXCEED THE DEPTHS AND TYPES OF THE LAYERS OF EXISTING PAVEMENT. SUBSURFACE DRAINAGE OF THE EXISTING AND PROPOSED PAVEMENT SHALL BE ADDRESSED IN THE PAVEMENT DESIGN.
3. A MINIMUM OF THREE CORES SHALL BE TAKEN ALONG THE CENTER OF THE ADJACENT TRAVEL LANE TO DETERMINE THE TYPE AND THICKNESS OF EXISTING PAVEMENT LAYERS. THESE CORES SHALL BE SPACED NO MORE THAN 500 FEET APART.
4. THE ADJACENT TRAVEL LANE SHALL BE MILLED A MINIMUM DEPTH OF 1½ INCHES AND REPLACED WITH AN ASPHALT SURFACE COURSE TO MATCH THE PROPOSED PAVEMENT WIDENING SURFACE COURSE, UNLESS WAIVED BY THE ENGINEER.
5. THE ENGINEER MAY REQUIRE THE MILLING DEPTH OF THE EXISTING PAVEMENT TO BE ADJUSTED TO ACHIEVE AN ACCEPTABLE PAVEMENT CROSS-SLOPE AND EFFECTIVE SURFACE DRAINAGE.
6. EXISTING PAVEMENT MARKINGS AND MARKERS WITHIN THE PROJECT LIMITS SHALL BE RESTORED SUBJECT TO THE APPROVAL OF THE ENGINEER.
7. FINAL TRANSVERSE PAVEMENT TIE-IN SHALL CONFORM TO THE REQUIREMENTS OF SECTION 315.05(c) OF THE SPECIFICATIONS EXCEPT THAT ALL JOINTS AT TIE-IN LOCATIONS SHALL BE TESTED USING A 10 FOOT STRAIGHTEDGE IN ACCORDANCE WITH THE REQUIREMENTS OF SECTION 315.07(q) OF THE SPECIFICATIONS.



ROAD AND BRIDGE STANDARDS

SHEET 1 OF 1

REVISION DATE

303.02

**ASPHALT PAVEMENT WIDENING
FOR WIDENING SUBJECT TO TRAFFIC**

VIRGINIA DEPARTMENT OF TRANSPORTATION

SPECIFICATION
REFERENCE

315

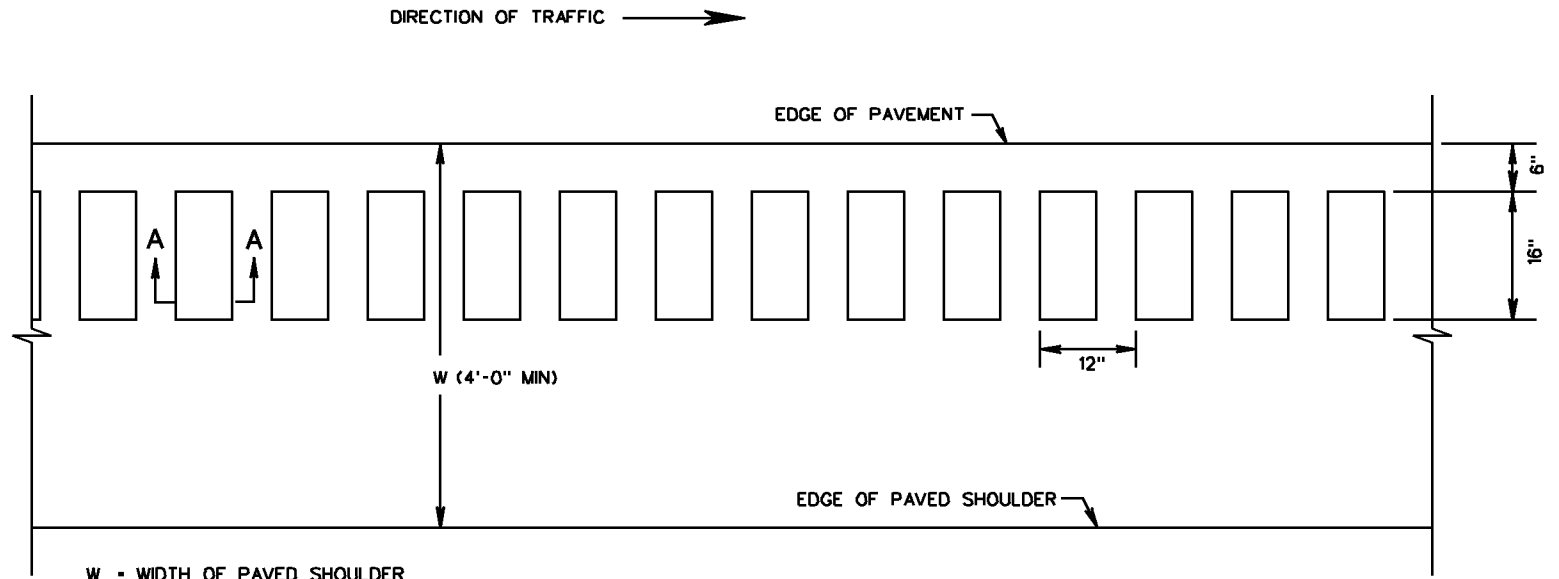

W - WIDTH OF PAVED SHOULDER

PLAN VIEW

NOTES

1. RUMBLE STRIPS SHALL BE PLACED CONTINUOUSLY AS DIRECTED BY THE ENGINEER.
2. RUMBLE STRIPS SHALL NOT BE PLACED WITHIN LIMITS OF BRIDGE DRAINAGE APRONS OR SPECIAL DESIGN SHOULDER SLOT INLETS.
3. RUMBLE STRIPS SHALL BE PLACED ON MAINLINE SHOULDERS ONLY.
4. FOLLOWING CUTTING AND CLEANING DEPRESSIONS OF WASTE MATERIAL, THE ENTIRE RUMBLE STRIP AREA SHALL BE COATED WITH LIQUID ASPHALT COATING (EMULSION) USING A PRESSURE DISTRIBUTOR AT AN APPROXIMATE RATE OF 0.1 GALLON PER SQUARE YARD. OVERSPRAY SHALL NOT EXTEND MORE THAN 2 INCHES BEYOND THE WIDTH OF CUT AND/OR SHALL NOT COME IN CONTACT WITH PAVEMENT MARKINGS.
5. RUMBLE STRIPS SHALL NOT BE PLACED WITHIN 50 FEET OF ANY INTERSECTION, TURN LANE, ACCELERATION/DECELERATION LANE OR GORE AREA.
6. PAVEMENT MARKINGS SHALL BE PLACED AS DIRECTED BY THE ENGINEER.

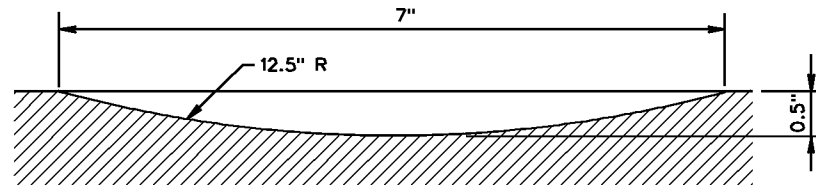

SECTION A-A

SPECIFICATION REFERENCE
310 315

CONTINUOUS SHOULDER RUMBLE STRIPS

VIRGINIA DEPARTMENT OF TRANSPORTATION

 ROAD AND BRIDGE STANDARDS	
REVISION DATE	SHEET 1 OF 1
10/09	304.01

← DIRECTION OF TRAFFIC

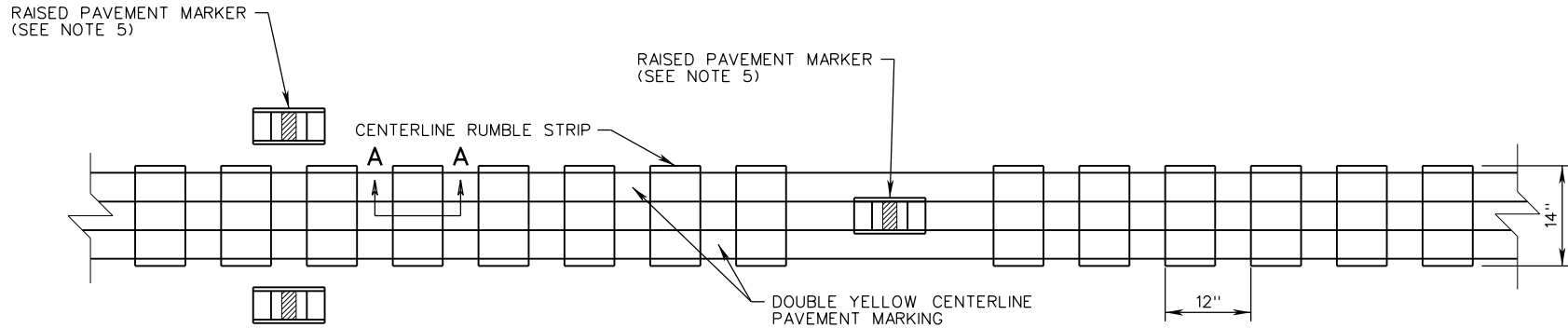

DIRECTION OF TRAFFIC →

PLAN VIEW

NOTES

1. CENTERLINE RUMBLE STRIPS SHALL NOT BE INSTALLED WITHIN THE LIMITS OF BRIDGES.
2. CENTERLINE RUMBLE STRIPS SHALL NOT BE INSTALLED ON SUBDIVISION STREETS OR IN NARROW UNMARKED ROAD SECTIONS WITHOUT PAVEMENT MARKINGS.
3. CENTERLINE RUMBLE STRIPS SHALL NOT BE INSTALLED WITHIN THE LIMITS OF CENTER TWO-WAY TURN LANES.
4. CENTERLINE RUMBLE STRIPS SHALL NOT BE INSTALLED IN PASSING ZONES EXCEPT AS DIRECTED BY THE TRAFFIC ENGINEER. THE DEPTH OF CENTERLINE RUMBLE STRIPS IN PASSING ZONES SHALL BE $\frac{3}{8}$ ".
5. USE OF RAISED PAVEMENT MARKERS IS OPTIONAL. SEE STANDARD PM-9 FOR DETAILS ON RAISED PAVEMENT MARKER PLACEMENT. WHEN NECESSARY TO ACCOMMODATE THE PM-9 STANDARD TWO GROOVES SHALL BE OMITTED EVERY 40' TO ALLOW FOR A CENTERLINE RAISED PAVEMENT MARKER.
6. WHERE A LEFT-TURN LANE IS MARKED, THE CONTINUOUS CENTERLINE RUMBLE STRIPS SHALL FOLLOW THE DOUBLE YELLOW MARKINGS OF THE OPPOSING LANES AND SHALL STOP 50 FEET FROM THE EDGE OF THE INTERSECTING DRIVEWAY OR ROADWAY.
7. FOLLOWING CUTTING AND CLEANING DEPRESSIONS OF WASTE MATERIAL, THE ENTIRE RUMBLE STRIP AREA SHALL BE COATED WITH LIQUID ASPHALT COATING (EMULSION) USING A PRESSURE DISTRIBUTOR AT AN APPROXIMATE RATE OF 0.1 GALLON PER SQUARE YARD. OVERSPRAY SHALL NOT EXTEND MORE THAN 2 INCHES BEYOND THE WIDTH OF CUT AND/OR SHALL NOT COME IN CONTACT WITH PAVEMENT MARKINGS.
8. PAVEMENT MARKINGS SHALL BE PLACED AS DIRECTED BY THE ENGINEER.

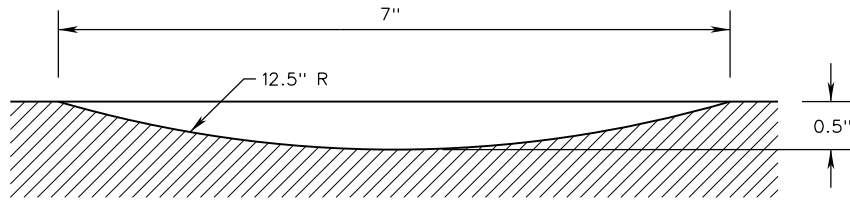

SECTION A-A



ROAD AND BRIDGE STANDARDS

CENTERLINE RUMBLE STRIPS

SPECIFICATION REFERENCE

SHEET 1 OF 1

REVISION DATE

310
315

304.02

7/13

VIRGINIA DEPARTMENT OF TRANSPORTATION

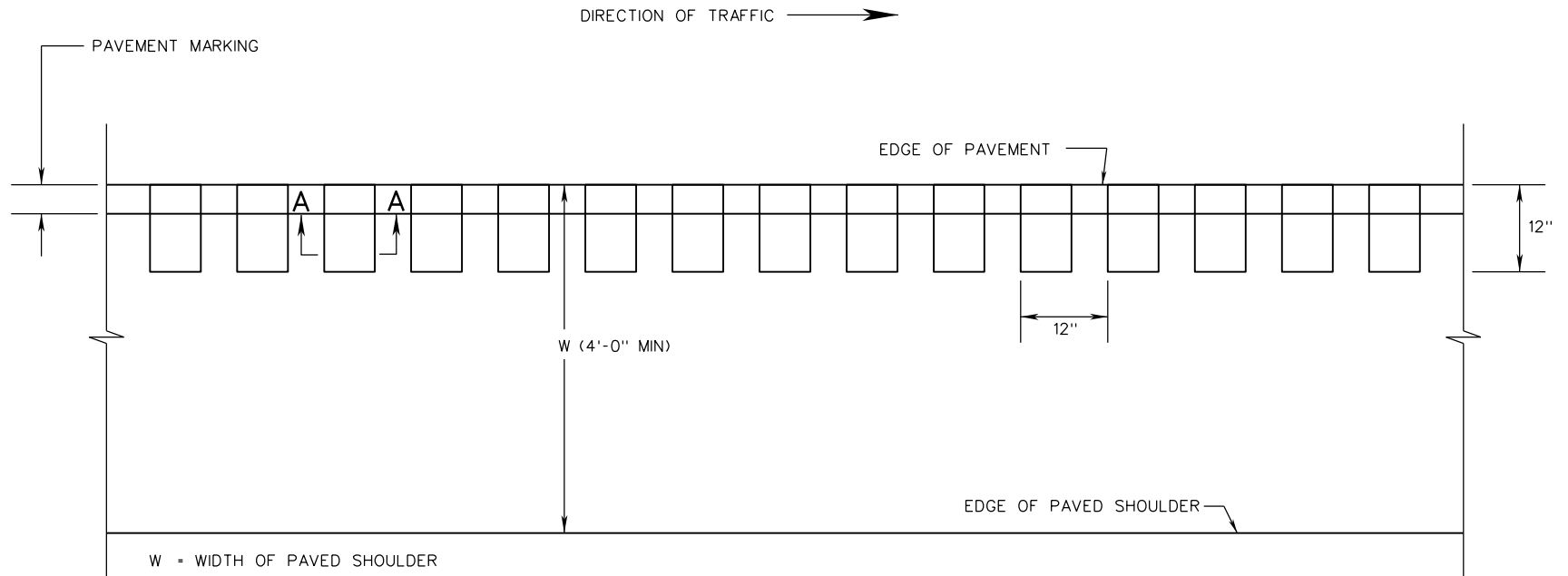

W = WIDTH OF PAVED SHOULDER

PLAN VIEW

NOTES

1. RUMBLE STRIPES SHALL BE PLACED CONTINUOUSLY AS DIRECTED BY THE ENGINEER.
2. RUMBLE STRIPES SHALL NOT BE PLACED WITHIN LIMITS OF BRIDGE DRAINAGE APRONS OR SPECIAL DESIGN SHOULDER SLOT INLETS.
3. RUMBLE STRIPES SHALL BE PLACED ON MAINLINE SHOULDERS ONLY.
4. FOLLOWING CUTTING AND CLEANING DEPRESSIONS OF WASTE MATERIAL, THE ENTIRE RUMBLE STRIP AREA SHALL BE COATED WITH LIQUID ASPHALT COATING (EMULSION) USING A PRESSURE DISTRIBUTOR AT AN APPROXIMATE RATE OF 0.1 GALLON PER SQUARE YARD. OVERSPRAY SHALL NOT EXTEND MORE THAN 2 INCHES BEYOND THE WIDTH OF CUT AND/OR SHALL NOT COME IN CONTACT WITH PAVEMENT MARKINGS.
5. RUMBLE STRIPES SHALL NOT BE PLACED WITHIN 50 FEET OF ANY INTERSECTION, TURN LANE, ACCELERATION/DECELERATION LANE OR GORE AREA.
6. PAVEMENT MARKINGS SHALL BE PLACED AS DIRECTED BY THE ENGINEER.

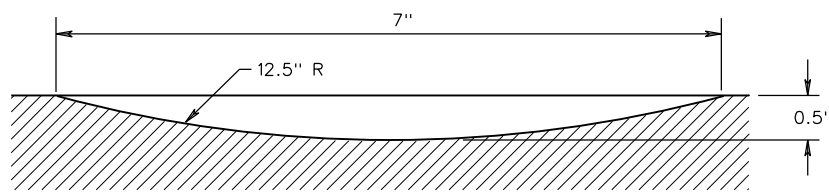

SECTION A-A

SPECIFICATION REFERENCE

310
315

A COPY OF THE ORIGINAL SEALED AND SIGNED STANDARD DRAWING IS ON FILE IN THE CENTRAL OFFICE

CONTINUOUS SHOULDER RUMBLE STRIPES

VIRGINIA DEPARTMENT OF TRANSPORTATION

VDOT

ROAD AND BRIDGE STANDARDS

REVISION DATE

7/13

SHEET 1 OF 1

304.03

RS-5

DIRECTION OF TRAFFIC →

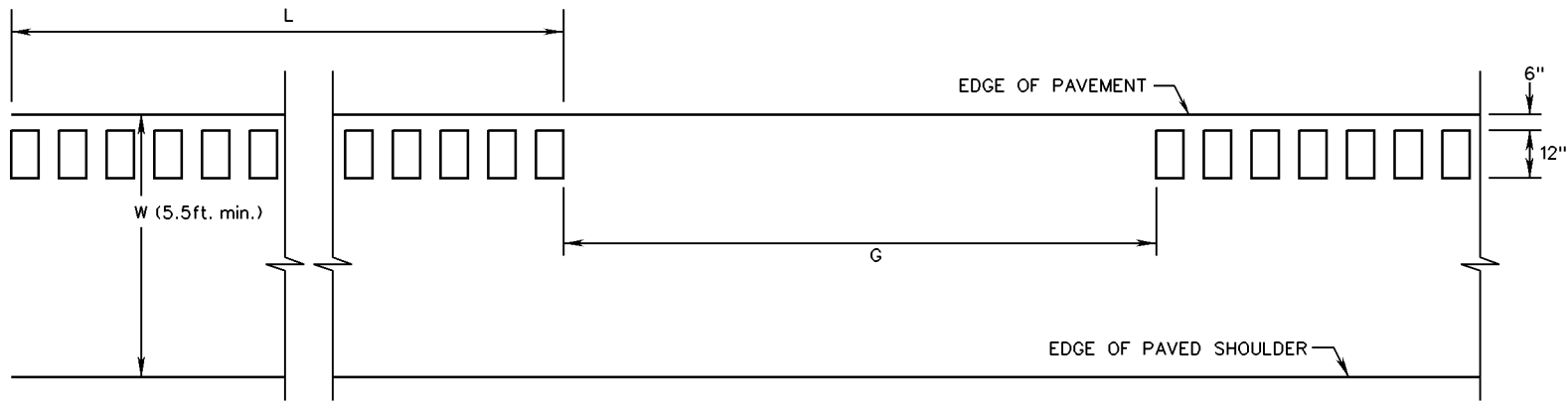

W = WIDTH OF PAVED SHOULDER

PLAN VIEW

	L	G
ROADWAY DOWN GRADE LESS THAN 6%	48 ft.	12 ft.
ROADWAY DOWN GRADE EQUAL TO 6% AND GREATER	52 ft.	16 ft.

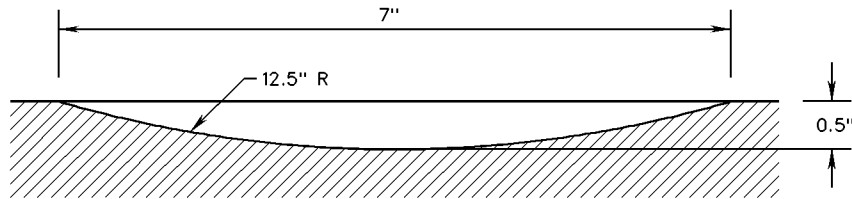

SECTION A-A

NOTES

1. RUMBLE STRIPS SHALL BE PLACED WITH AN INTERMITTENT PATTERN AS SHOWN IN THE PLAN VIEW AND SHALL BE INSTALLED IN THE LOCATIONS SHOWN ON THE PLANS, OR AS DIRECTED BY THE ENGINEER.
2. RUMBLE STRIPS SHALL NOT BE PLACED WITHIN LIMITS OF BRIDGE DRAINAGE APRONS OR SPECIAL DESIGN SHOULDER SLOT INLETS.
3. RUMBLE STRIPS SHALL BE PLACED ON MAINLINE SHOULDERS ONLY.
4. INTERMITTENT RUMBLE STRIPS SHALL BE PLACED ON OUTSIDE SHOULDERS ONLY.
5. FOLLOWING CUTTING AND CLEANING DEPRESSIONS OF WASTE MATERIAL, THE ENTIRE RUMBLE STRIP AREA SHALL BE COATED WITH LIQUID ASPHALT COATING (EMULSION) USING A PRESSURE DISTRIBUTOR AT AN APPROXIMATE RATE OF 0.1 GALLON PER SQUARE YARD. OVERSPRAY SHALL NOT EXTEND MORE THAN 2 INCHES BEYOND THE WIDTH OF CUT AND/OR SHALL NOT COME IN CONTACT WITH PAVEMENT MARKINGS.
6. RUMBLE STRIPS SHALL NOT BE PLACED WITHIN 50 FEET OF ANY INTERSECTION, TURN LANE, ACCELERATION/DECELERATION LANE OR GORE AREA.
7. PAVEMENT MARKINGS SHALL BE PLACED AS DIRECTED BY THE ENGINEER.



ROAD AND BRIDGE STANDARDS

SHEET 1 OF 1

REVISION DATE

304.04

08/10

A COPY OF THE ORIGINAL SEALED AND SIGNED STANDARD DRAWING IS ON FILE IN THE CENTRAL OFFICE

INTERMITTENT SHOULDER RUMBLE STRIPS

VIRGINIA DEPARTMENT OF TRANSPORTATION

SPECIFICATION REFERENCE

310
315

NOTES

1. TIE-IN REQUIREMENTS TO INTERSECTING ROADS OR STREETS SHALL BE IN ACCORDANCE WITH THE CONTRACT DOCUMENTS OR AT THE DIRECTION OF THE ENGINEER.
2. EXISTING PAVEMENT SURFACE SHALL BE PLANNED TO TRANSITION THE TOP COURSE OF THE ASPHALT CONCRETE OVERLAY. ANY SUB-COURSE TERMINATION MAY BE NOTCHED INTO THE EXISTING PAVEMENT OR BLENDED WITH THE NEXT COURSE OF PAVEMENT.
3. WHEN THERE IS A SPECIAL PROVISION FOR RIDEABILITY INCLUDED IN THE CONTRACT, A DISTANCE OF 105 FEET (0.02 OF A MILE), MEASURED FROM THE LINE OF THE TIE-IN WILL BE EXEMPTED FROM PAY ADJUSTMENT.
4. TRANSITION SHALL BEGIN/END AT THE PROJECT LIMITS, AT BRIDGE APPROACH SLAB/ABUTMENT (OR AN INTERMEDIATE POINT DETERMINED BY THE ENGINEER), AND A MINIMUM OF 75 FEET FROM A VERTICAL PLANE OF THE NEAREST OUTER FACE OF THE BRIDGE OVERPASS.
5. NO OVERLAY OR MILLING SHALL BE PERMITTED ON THE BRIDGE DECK WITHOUT THE PRIOR WRITTEN APPROVAL OF THE DISTRICT BRIDGE ENGINEER.

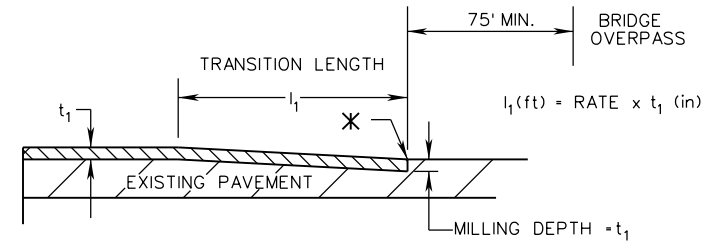

SINGLE COURSE OVERLAY TRANSITION GEOMETRY
(NOT TO SCALE)

✱ BRIDGE DECK OR PROJECT TERMINI

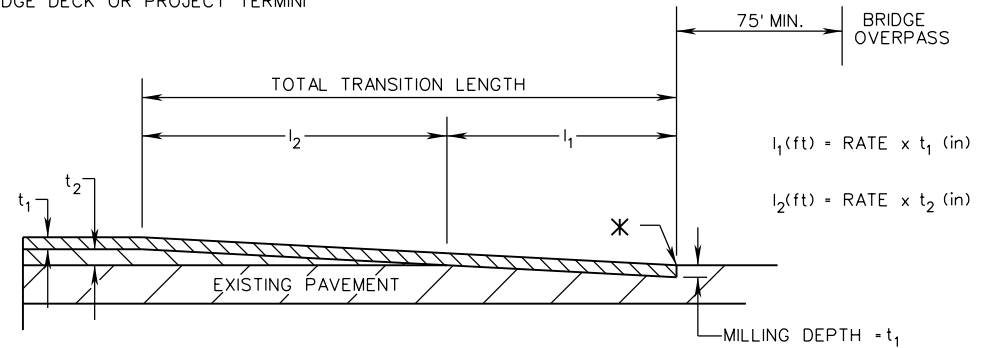

TWO COURSE OVERLAY TRANSITION GEOMETRY
(NOT TO SCALE)

TRANSITION RATE		POSTED SPEED MPH					
		25	35	45	55	65	70
RATE (FT/INCH)		20	25	35	40	45	50

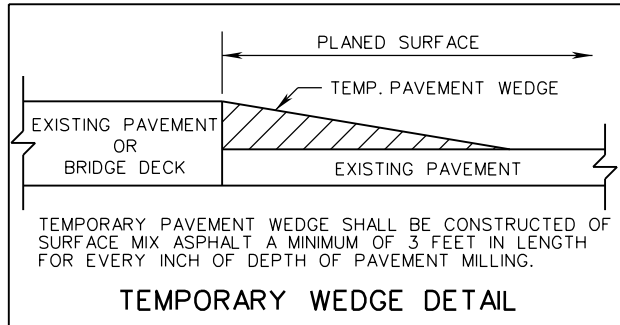

TEMPORARY WEDGE DETAIL

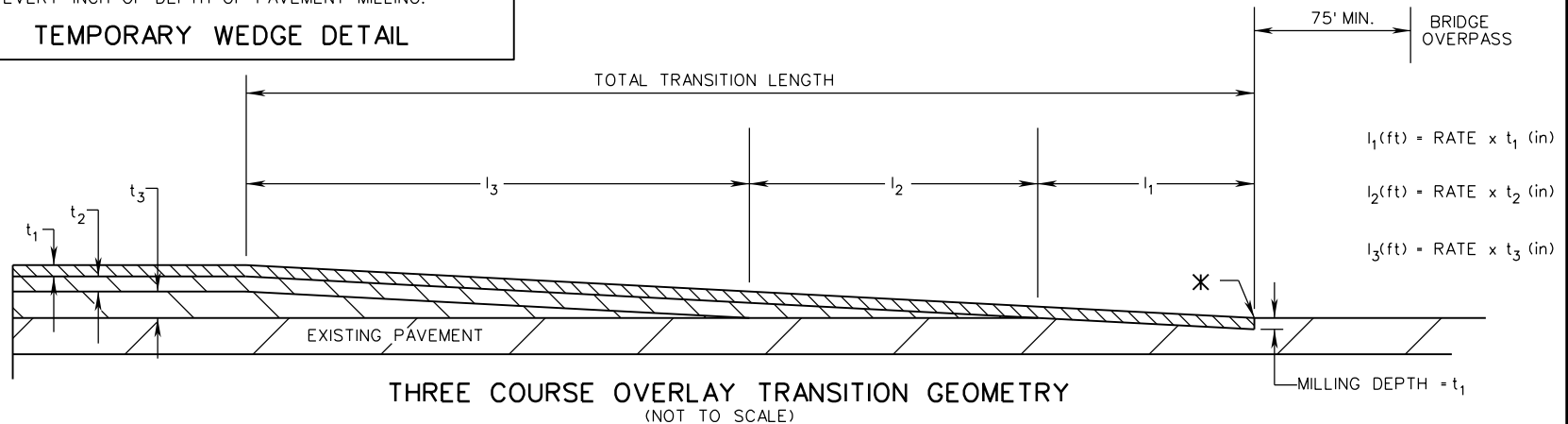

THREE COURSE OVERLAY TRANSITION GEOMETRY
(NOT TO SCALE)

SPECIFICATION REFERENCE

- 210
- 315
- 515

A COPY OF THE ORIGINAL SEALED AND SIGNED DRAWING IS ON FILE IN THE CENTRAL OFFICE.
ASPHALT CONCRETE OVERLAY TRANSITIONS

VIRGINIA DEPARTMENT OF TRANSPORTATION

VDOT

ROAD AND BRIDGE STANDARDS

REVISION DATE

SHEET 1 OF 1

7/12

305.01

THIS PAGE INTENTIONALLY LEFT BLANK



ROAD AND BRIDGE STANDARDS

SHEET 1 OF 1

REVISION DATE

305.02

VIRGINIA DEPARTMENT OF TRANSPORTATION

SPECIFICATION
REFERENCE

SECTION 400

RETAINING WALLS

THIS PAGE INTENTIONALLY LEFT BLANK



ROAD AND BRIDGE STANDARDS

SHEET 1 OF 1

REVISION DATE

SPECIFICATION
REFERENCE

VIRGINIA DEPARTMENT OF TRANSPORTATION

STANDARD	TITLE	PAGE
RW-2	CONCRETE GRAVITY RETAINING WALLS - LEVEL BACKFILL	401.01
RW-3	CONCRETE GRAVITY RETAINING WALLS INFINITE SURCHARGE AND DECK SURCHARGE - LOADED	401.02
RW-2, 3	SUGGESTED RUSTICATION TREATMENTS FOR RETAINING WALLS	401.03
CW-1	STANDARD REINFORCED CONCRETE CRIB WALL	402.01
	STANDARD REINFORCED CONCRETE CRIB WALL	402.02

INDEX OF SHEETS
SECTION 400-RETAINING WALLS
 VIRGINIA DEPARTMENT OF TRANSPORTATION



ROAD AND BRIDGE STANDARDS

REVISION DATE

SHEET 1 OF 1

400.01

THIS PAGE INTENTIONALLY LEFT BLANK



ROAD AND BRIDGE STANDARDS

SHEET 1 OF 1

REVISION DATE

400.02

VIRGINIA DEPARTMENT OF TRANSPORTATION

SPECIFICATION
REFERENCE

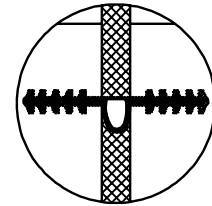
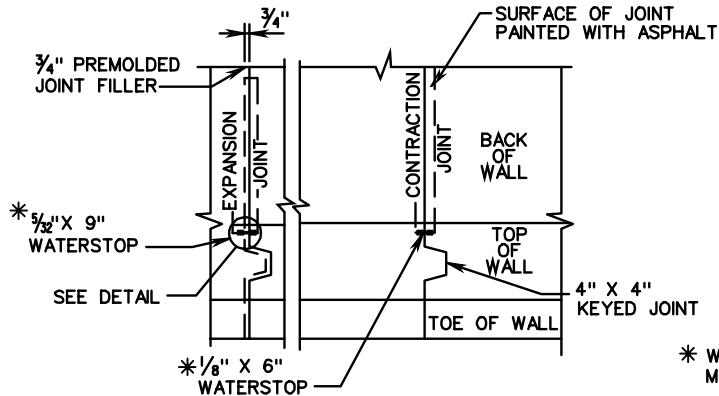

**WATERSTOP
DETAIL**

* WATER STOPS TO BE ELASTOMERIC OR OTHER APPROVED MATERIAL. DIMENSIONS SHOWN ARE ABSOLUTE MINIMUM.
EXPANSION JOINTS AT INTERVALS NOT EXCEEDING 90'.

HEIGHT OF WALL "H" IN FEET	THICKNESS AT TOP "A" IN FEET	THICKNESS AT BASE B=4H	COMPRESSION AT TOE LBS. PER SQ. FT.	AREA OF SECTION SQ. FT.
2	1'-0"	1'-0"	627	2.63
3	"	1'-2 ³ / ₈ "	1009	3.93
4	"	1'-7 ¹ / ₄ "	1369	5.83
5	"	2'-0"	1709	8.13
6	"	2'-4 ³ / ₄ "	2049	10.83
7	"	2'-9 ⁵ / ₈ "	2385	13.93
8	"	3'-2 ³ / ₈ "	2720	17.43
9	"	3'-7 ¹ / ₄ "	3054	21.33
10	"	4'-0"	3386	25.63
11	"	4'-4 ³ / ₄ "	3718	30.33
12	"	4'-9 ⁵ / ₈ "	4050	35.43
13	"	5'-2 ³ / ₈ "	4381	40.93
14	"	5'-7 ¹ / ₄ "	4712	46.83
15	"	6'-0"	5043	53.13

H - HEIGHT IN FT.
A - 1'
BASE - 4/10 H
EARTH - 100 LBS.
CONCRETE - 150 LBS.
ANGLE OF REPOSE - 1 1/2: 1

POROUS BACKFILL @ 100 LBS./CU. FT.
#78 OR #8 AGGREGATE OR CRUSHED GLASS
MEETING #78 OR #8 GRADATION REQUIREMENTS

3" DRAIN PIPE 8' APART
WEEP HOLE WITH 12"X12" PLASTIC HARDWARE CLOTH 1/4" MESH OR GALVANIZED STEEL WIRE, MINIMUM WIRE DIAMETER 0.03", #4 MESH HARDWARE CLOTH ANCHORED FIRMLY TO OUTSIDE OF STRUCTURE.

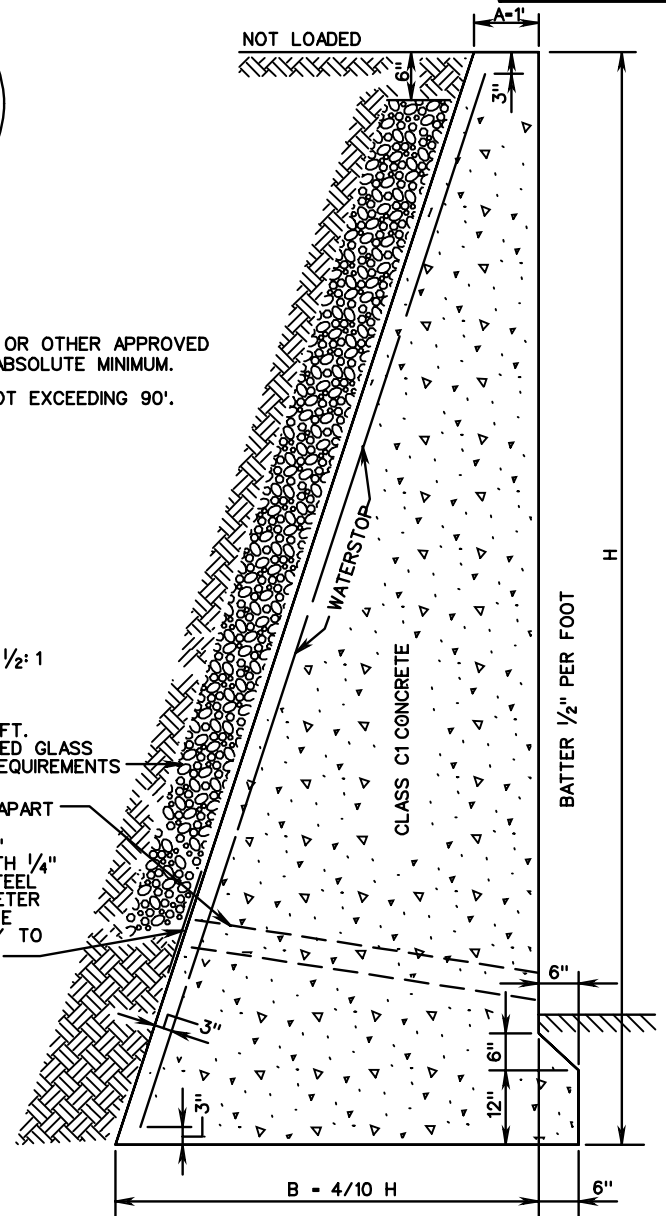

NOTE:
IF COMPRESSION AT TOE EXCEEDS SAFE BEARING CAPACITY OF SOIL, A SPECIAL FOOTING IS TO BE USED.
DEPTH OF WALL IN GROUND DETERMINED BY CONDITIONS. TO BE NOT LESS THAN 1'-6".

SAFE BEARING CAPACITY OF SOIL	
ROCK MINIMUM.....	10,000 - 20,000 LBS. PER SQ. FT.
GRAVEL AND COARSE SAND, WELL CEMENTED	16,000 - 20,000 LBS. PER SQ. FT.
CLAY IN THICK BEDS, ALWAYS DRY.....	12,000 - 16,000 LBS. PER SQ. FT.
CLAY IN THICK BEDS, MODERATELY DRY.....	8,000 - 12,000 LBS. PER SQ. FT.
CLAY, SOFT	2,000 - 4,000 LBS. PER SQ. FT.
SAND, DRY, COMPACT, AND WELL CEMENTED	8,000 - 12,000 LBS. PER SQ. FT.
SAND, CLEAN, DRY	4,000 - 8,000 LBS. PER SQ. FT.
ALLUVIAL SOILS, ETC	1,000 - 2,000 LBS. PER SQ. FT.

SPECIFICATION REFERENCE
506

CONCRETE GRAVITY RETAINING WALL - LEVEL BACKFILL

VIRGINIA DEPARTMENT OF TRANSPORTATION

VDOT	
ROAD AND BRIDGE STANDARDS	
REVISION DATE	SHEET 1 OF 1
401.01	

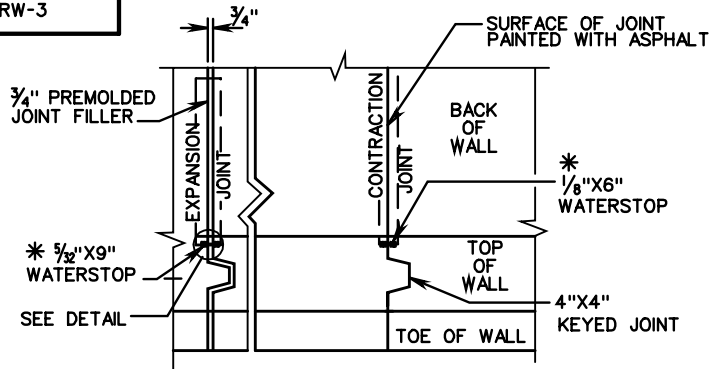

CONTRACTION JOINTS AT INTERVALS NOT EXCEEDING 30'.
EXPANSION JOINTS AT INTERVALS NOT EXCEEDING 90'.

* WATER STOPS TO BE ELASTOMERIC OR OTHER APPROVED MATERIAL. DIMENSIONS SHOWN ARE ABSOLUTE MINIMUM.

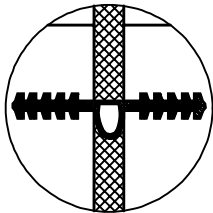

WATERSTOP
DETAIL

HEIGHT OF WALL "H" IN FEET	THICKNESS AT TOP "A" IN FEET	THICKNESS AT BASE B=.6H	COMPRESSION AT TOE LBS. PER SQ. FT.	AREA OF SECTION SQ. FT.
3	1'-0"	1'-9 $\frac{5}{8}$ "	856	4.83
4	1'-0"	2'-4 $\frac{3}{4}$ "	1141	7.43
5	1'-0"	3'-0"	1427	10.63
6	1'-0"	3'-7 $\frac{1}{4}$ "	1712	14.43
7	1'-0"	4'-2 $\frac{3}{8}$ "	1997	18.83
8	1'-0"	4'-9 $\frac{5}{8}$ "	2283	23.83
9	1'-0"	5'-4 $\frac{3}{4}$ "	2568	29.43
10	1'-0"	6'-0"	2853	35.63
11	1'-1 1/4 "	6'-7 $\frac{1}{4}$ "	3139	42.98
12	1'-2 3/8 "	7'-2 $\frac{3}{8}$ "	3424	51.03
13	1'-3 5/8 "	7'-9 $\frac{5}{8}$ "	3709	59.78
14	1'-4 3/4 "	8'-4 $\frac{3}{4}$ "	3995	69.23
15	1'-6"	9'-0"	4280	79.38

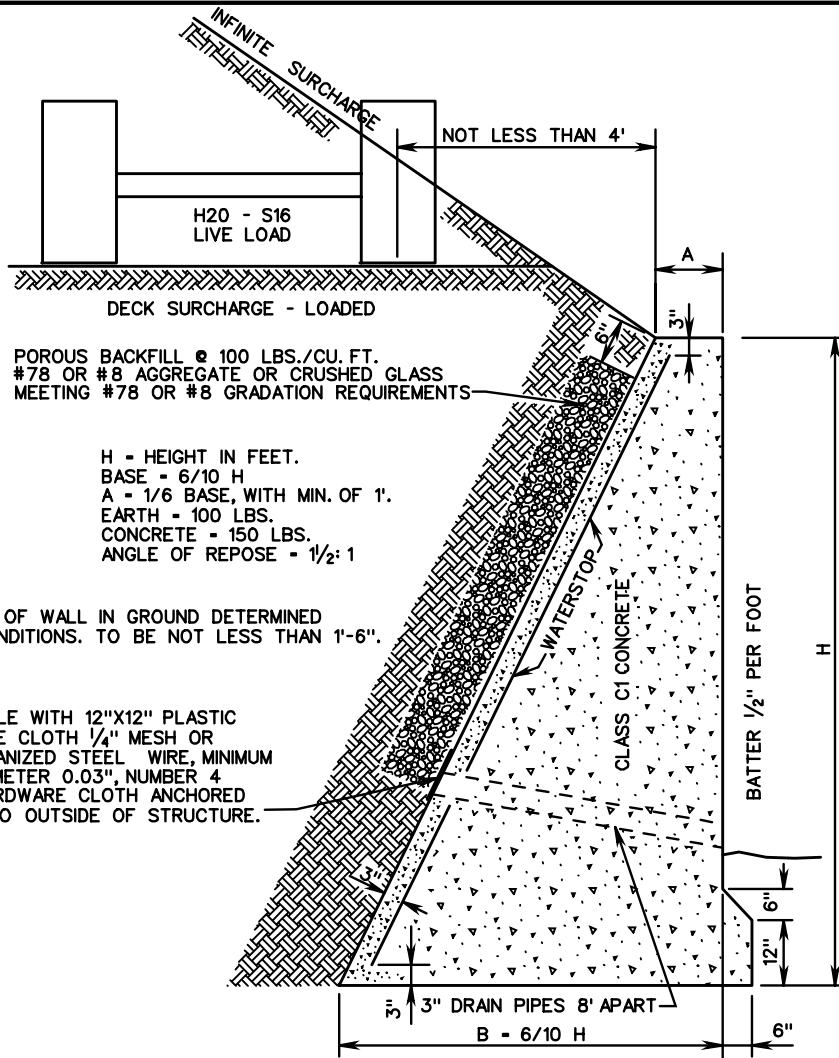

NOTE:
DEPTH OF WALL IN GROUND DETERMINED BY CONDITIONS. TO BE NOT LESS THAN 1'-6".

WEEP HOLE WITH 12"X12" PLASTIC HARDWARE CLOTH 1/4" MESH OR GALVANIZED STEEL WIRE, MINIMUM WIRE DIAMETER 0.03", NUMBER 4 MESH HARDWARE CLOTH ANCHORED FIRMLY TO OUTSIDE OF STRUCTURE.

SAFE BEARING CAPACITY OF SOIL	
ROCK MINIMUM.....	10,000 - 20,000 LBS. PER SQ. FT.
GRAVEL AND COARSE SAND, WELL CEMENTED	16,000 - 20,000 LBS. PER SQ. FT.
CLAY IN THICK BEDS, ALWAYS DRY.....	12,000 - 16,000 LBS. PER SQ. FT.
CLAY IN THICK BEDS, MODERATELY DRY.....	8,000 - 12,000 LBS. PER SQ. FT.
CLAY, SOFT.....	2,000 - 4,000 LBS. PER SQ. FT.
SAND, DRY, COMPACT, AND WELL CEMENTED	8,000 - 12,000 LBS. PER SQ. FT.
SAND, CLEAN, DRY	4,000 - 8,000 LBS. PER SQ. FT.
ALLUVIAL SOILS, ETC	1,000 - 2,000 LBS. PER SQ. FT.

NOTE: IF COMPRESSION AT TOE EXCEEDS SAFE BEARING CAPACITY OF SOIL, A SPECIAL FOOTING IS TO BE USED.



CONCRETE GRAVITY RETAINING WALLS INFINITE SURCHARGE AND DECK SURCHARGE - LOADED

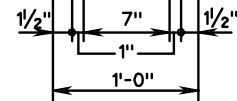
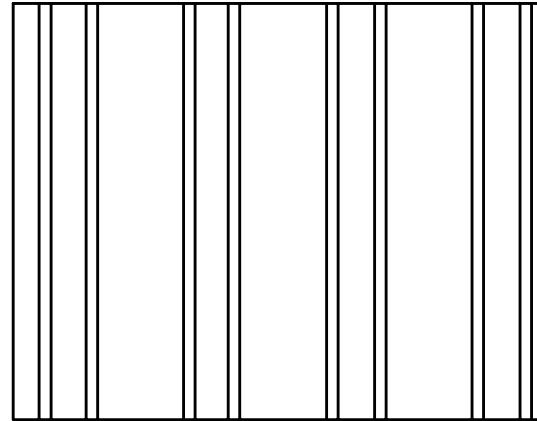
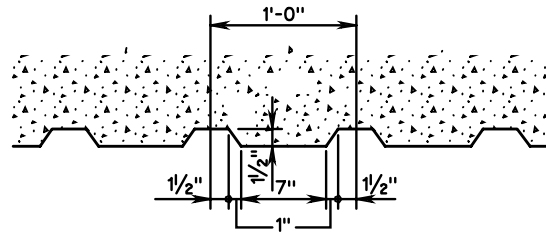

VERTICAL GROOVE

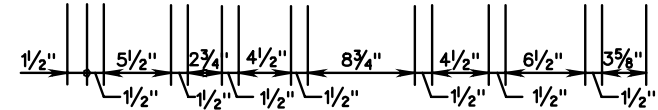
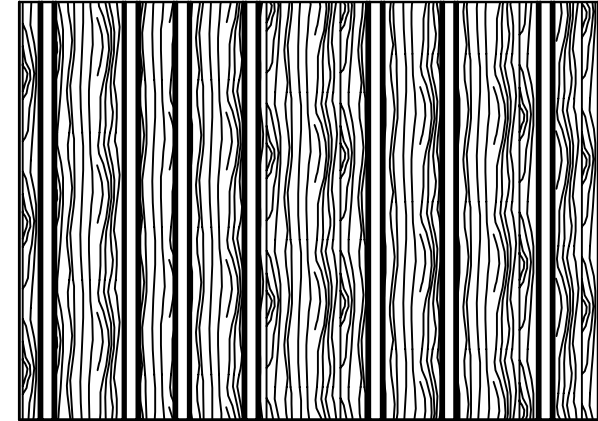
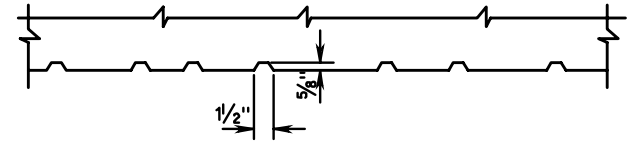

RANDOM BOARD RUSTICATION

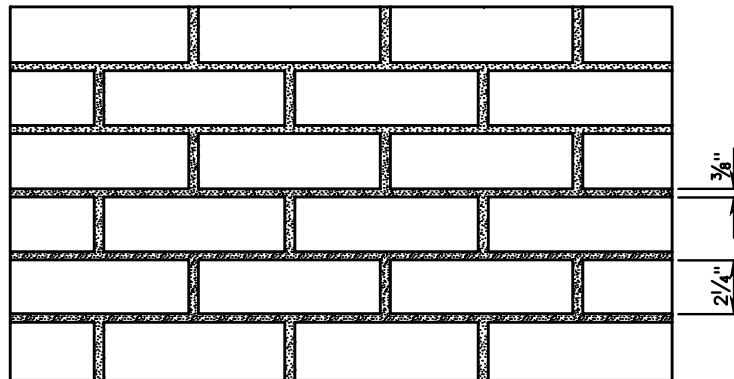

BRICK

NOTES:

RUSTIC TREATMENTS FOR STANDARD RW-2 AND RW-3 CONCRETE GRAVITY RETAINING WALLS ARE TO BE CONSIDERED WHERE LARGE AREAS ARE SUBJECT TO VIEWING BY GENERAL PUBLIC. AS A GENERAL GUIDELINE THE USE OF SUCH TREATMENT WILL BE CONSIDERED ON WALLS WHERE THE HEIGHT IS 3' OR GREATER.

THE SELECTION OF THE PROPOSED TREATMENT SHOULD BE MADE AT THE FIELD INSPECTION REVIEW AND PARTICULAR ATTENTION GIVEN IF THE PROPOSED WALL TIES INTO A BRIDGE ABUTMENT TO INSURE THAT BOTH HAVE THE SAME TREATMENT.

IF ENVIRONMENTAL CONSIDERATIONS DICTATE, OTHER TYPES OF TREATMENTS CAN BE USED.

SPECIFICATION REFERENCE

506

SUGGESTED RUSTICATION TREATMENTS FOR RETAINING WALLS

VIRGINIA DEPARTMENT OF TRANSPORTATION

VDOT

ROAD AND BRIDGE STANDARDS

REVISION DATE

SHEET 1 OF 1

401.03

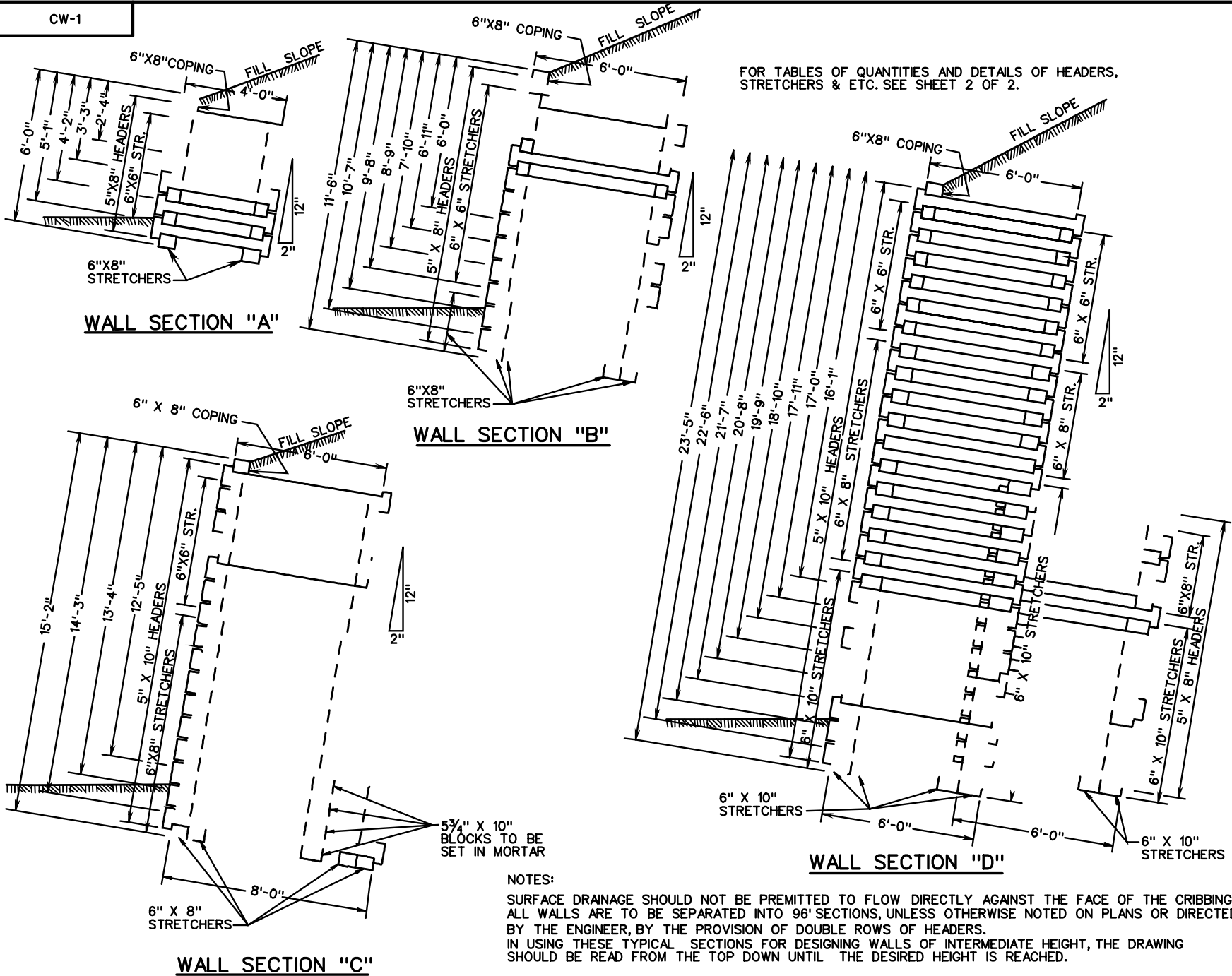

FOR TABLES OF QUANTITIES AND DETAILS OF HEADERS, STRETCHERS & ETC. SEE SHEET 2 OF 2.

NOTES:
 SURFACE DRAINAGE SHOULD NOT BE PERMITTED TO FLOW DIRECTLY AGAINST THE FACE OF THE CRIBBING. ALL WALLS ARE TO BE SEPARATED INTO 96' SECTIONS, UNLESS OTHERWISE NOTED ON PLANS OR DIRECTED BY THE ENGINEER, BY THE PROVISION OF DOUBLE ROWS OF HEADERS.
 IN USING THESE TYPICAL SECTIONS FOR DESIGNING WALLS OF INTERMEDIATE HEIGHT, THE DRAWING SHOULD BE READ FROM THE TOP DOWN UNTIL THE DESIRED HEIGHT IS REACHED.

VDOT	
ROAD AND BRIDGE STANDARDS	
SHEET 1 OF 2	REVISION DATE
402.01	

STANDARD REINFORCING CONCRETE CRIB WALL

SPECIFICATION REFERENCE
506

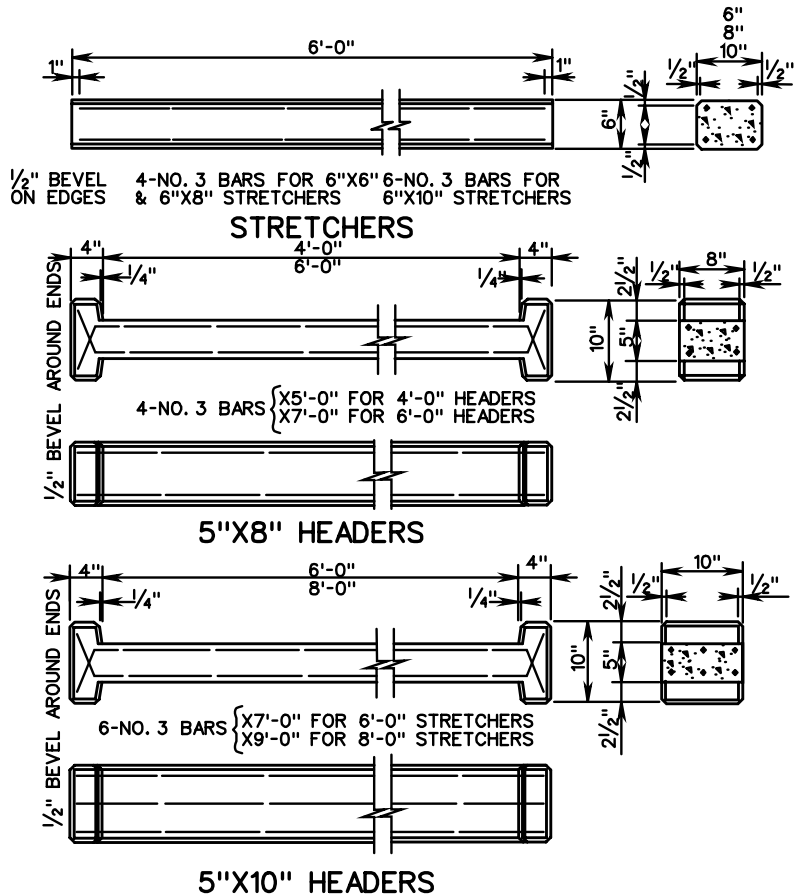

1/2" BEVEL ON EDGES 4-NO. 3 BARS FOR 6"X6" & 6"X8" STRETCHERS 6-NO. 3 BARS FOR 6"X10" STRETCHERS

STRETCHERS

4-NO. 3 BARS { X5'-0" FOR 4'-0" HEADERS
X7'-0" FOR 6'-0" HEADERS

5"X8" HEADERS

6-NO. 3 BARS { X7'-0" FOR 6'-0" STRETCHERS
X9'-0" FOR 8'-0" STRETCHERS

5"X10" HEADERS

UNIT	WEIGHT	CU. FT.
5"X8"X4'-0" HEADER	235#	1.48
5"X8"X6'-0" HEADER	325#	2.04
5"X10"X6'-0" HEADER	405#	2.55
5"X10"X8'-0" HEADER	515#	3.24
6"X6"X6'-0" STRETCHER	240#	1.50
6"X8"X6'-0" HEADER	320#	2.00
6"X10"X6'-0" HEADER	400#	2.50
5 3/4"X10"X10" BLOCK	50#	0.33

NOTES:
ALL REINFORCING TO BE NO. 3 BARS PLACED 1" CLEAR FROM SURFACE OF CONCRETE.
BARS TO BE HELD IN POSITION BY CHAIRS HAVING NON-CORROSIVE TIPS
CLASS A-5 CONCRETE TO BE USED EXCEPT MAXIMUM SIZE AGGREGATE TO BE NO. 7.

HEIGHT OF WALL	UNITS REQUIRED FOR TYPICAL WALL 96' LONG						WALL SECTION	
	HEADERS			STRETCHERS				BL'K'S 5 3/4"X 10"X10"
	5"X8" X4'-0"	5"X8" X6'-0"	5"X10" X6'-0"	5"X10" X8'-0"	6"X6" X6'-0"	6"X8" X6'-0"		
2'-4"	34				32	48		
3'-3"	51				64	48		
4'-2"	68				96	48		
5'-1"	85				128	48		
6'-0"	102				160	48		
6'-0"		102			224	16		
6'-11"		119			256	16		
7'-10"		136			288	16		
8'-9"		153			320	16		
9'-8"		170			288	80		
10'-7"		187			288	112		
11'-6"		204			288	144		
12'-5"			204	17	192	272	17	
13'-4"			204	34	192	304	34	
14'-3"			204	51	192	336	51	
15'-2"			204	68	192	368	68	
16'-1"		68	289		192	336	144	
17'-0"		85	306		192	320	208	
17'-11"		102	323		192	320	256	
18'-10"		119	340		192	320	304	
19'-9"		136	357		192	320	352	
20'-8"		153	374		192	320	400	
21'-7"		170	391		192	320	448	
22'-6"		187	408		192	320	496	
23'-5"		204	425		192	320	544	

CRIBBING IS TO BE PLACED ON A FOUNDATION OF FIRM BEARING MATERIAL MEETING THE APPROVAL OF THE ENGINEER.
THIS FOUNDATION IS TO BE AT LEAST 3' BELOW THE SURFACE OF THE GROUND, BEYOND ALL DANGER OF FROST, UNLESS ON SOLID ROCK.
FOR DETAILS NOT SHOWN ON THIS SHEET, SEE SHEET 1 OF 2.
BLOCKS SHALL BE SET IN MORTAR.

SPECIFICATION REFERENCE
506

STANDARD REINFORCED CONCRETE CRIB WALL

VIRGINIA DEPARTMENT OF TRANSPORTATION

VDOT	
ROAD AND BRIDGE STANDARDS	
REVISION DATE	SHEET 2 OF 2
402.02	

THIS PAGE INTENTIONALLY LEFT BLANK



ROAD AND BRIDGE STANDARDS

SHEET 1 OF 1

REVISION DATE

402.03

VIRGINIA DEPARTMENT OF TRANSPORTATION

SPECIFICATION
REFERENCE

SECTION 500

GUARDRAIL, MEDIAN BARRIER,
FENCING & MARKERS

THIS PAGE INTENTIONALLY LEFT BLANK



ROAD AND BRIDGE STANDARDS

SHEET 1 OF 1

REVISION DATE

SPECIFICATION
REFERENCE

VIRGINIA DEPARTMENT OF TRANSPORTATION

STANDARD	TITLE	PAGE
GR-HDW	STANDARD W-BEAM GUARDRAIL HARDWARE	501.01
	STANDARD W-BEAM GUARDRAIL HARDWARE	501.02
	STANDARD THRIE BEAM GUARDRAIL HARDWARE	501.03
GR-2, 2A	STANDARD BLOCKED-OUT W-BEAM GUARDRAIL (STRONG POST SYSTEM)	501.04
	STANDARD BLOCKED-OUT W-BEAM GUARDRAIL (STRONG POST SYSTEM) POST AND BLOCKOUT DETAILS	501.05
GR-3	CABLE GUARDRAILS	501.06
	CABLE GUARDRAILS	501.07
	CABLE GUARDRAILS	501.08
GR-6	TERMINAL TREATMENT FOR W-BEAM GUARDRAIL	501.09
	TERMINAL TREATMENT FOR W-BEAM GUARDRAIL	501.10
GR-7	BREAKWAY CABLE TERMINAL - 4' FLARE	501.11
	BREAKWAY CABLE TERMINAL - 4' FLARE	501.12
	BREAKWAY CABLE TERMINAL - 4' FLARE (SITE PREPARATION)	501.13
GR-8, 8A, 8B, 8C	STANDARD W-BEAM GUARDRAIL (WEAK POST SYSTEM)	501.14
	STANDARD W-BEAM GUARDRAIL (WEAK POST SYSTEM)	501.15
GR-9	ALTERNATE BREAKAWAY CABLE TERMINAL - NO FLARE	501.16
	ALTERNATE BREAKAWAY CABLE TERMINAL - NO FLARE (SITE PREPARATION)	501.17
GR-10	GUARDRAIL AT LOW-FILL CULVERT	501.18
	GUARDRAIL AT LOW-FILL CULVERT	501.19
GR-11	TRAILING END TERMINAL TREATMENT	501.20
BGR-01	STANDARD BOX CULVERT GUARDRAIL (TEXAS T6)	501.22
	STANDARD BOX CULVERT GUARDRAIL (TEXAS T6)	501.23
	STANDARD BOX CULVERT GUARDRAIL (TEXAS T6)	501.24
GR-FOA-1	W BEAM GUARDRAIL-FIXED OBJECT ATTACHMENT FOR USE WITH VERTICAL FIXED OBJECTS AND GUARDRAIL (WOOD POSTS)	501.25
	W BEAM GUARDRAIL-FIXED OBJECT ATTACHMENT FOR USE WITH VERTICAL FIXED OBJECTS AND GUARDRAIL (STEEL POSTS)	501.26
	W BEAM GUARDRAIL-FIXED OBJECT ATTACHMENT RUBRAIL AND HARDWARE DETAILS	501.27
GR-FOA-2	W BEAM GUARDRAIL-FIXED OBJECT ATTACHMENT FOR USE BETWEEN SAFETY SHAPE AND AND GUARDRAIL (WOOD POSTS)	501.28
	W BEAM GUARDRAIL-FIXED OBJECT ATTACHMENT FOR USE BETWEEN SAFETY SHAPE AND AND GUARDRAIL (STEEL POSTS)	501.29
GR-FOA-2, & 4	W BEAM GUARDRAIL-FIXED OBJECT ATTACHMENT RUBRAIL AND HARDWARE DETAILS	501.30
GR-FOA-4	BLOCKED-OUT W-BEAM MEDIAN BARRIER - FIXED OBJECT ATTACHMENT FOR USE BETWEEN MB-7 AND MB-3	501.31
	BLOCKED-OUT W-BEAM MEDIAN BARRIER - FIXED OBJECT ATTACHMENT RUBRAIL AND HARDWARE DETAILS	501.32
FOA-CZ	W-BEAM GUARDRAIL INSTALLATION CRITERIA (FIXED OBJECT ATTACHMENT METHODS FOR CONSTRUCTION ZONES)	501.33
GR-INS	W-BEAM GUARDRAIL INSTALLATION CRITERIA	501.34
	W-BEAM GUARDRAIL INSTALLATION CRITERIA	501.35
	W-BEAM GUARDRAIL INSTALLATION CRITERIA	501.36
	W-BEAM GUARDRAIL INSTALLATION CRITERIA	501.37

INDEX OF SHEETS
SECTION 500-GUARDRAIL, BARRIER AND FENCE

VIRGINIA DEPARTMENT OF TRANSPORTATION



ROAD AND BRIDGE STANDARDS

REVISION DATE

SHEET 1 OF 2

500.01

STANDARD	TITLE	PAGE
GR-INS	W BEAM GUARDRAIL INSTALLATION CRITERIA	501.38
	W BEAM GUARDRAIL INSTALLATION CRITERIA	501.39
	W BEAM GUARDRAIL INSTALLATION CRITERIA	501.40
	W BEAM GUARDRAIL AND MEDIAN BARRIER INSTALLATION CRITERIA	501.41
MB-3	BLOCKED-OUT W BEAM MEDIAN BARRIER	502.01
MB-5	STANDARD W BEAM MEDIAN BARRIER (WEAK POST SYSTEM)	502.02
	STANDARD W BEAM MEDIAN BARRIER (WEAK POST SYSTEM)	502.03
MB-7D, 7E, 7F	CONCRETE MEDIAN BARRIER	502.04
MB-7D PC	PRECAST TRAFFIC BARRIER CONCRETE SERVICE	502.05
	PRECAST TRAFFIC BARRIER CONCRETE SERVICE	502.06
MB-8A	CONCRETE MEDIAN BARRIER TYPE I, II OR III	502.07
	CONCRETE MEDIAN BARRIER TYPE I, II, OR III	502.08
MB-9A	CAST IN PLACE CONCRETE MEDIAN BARRIER 12 FOOT TERMINAL SECTION.	502.09
MB-9A, PC	PRECAST CONCRETE MEDIAN BARRIER 12 FOOT TERMINAL SECTION	502.10
MB-10A	TRAFFIC BARRIER SERVICE CONCRETE PARAPET (SINGLE FACE) (FOR TEMPORARY INSTALLATION ON BRIDGE DECK EXTERIOR)	502.11
	TRAFFIC BARRIER SERVICE CONCRETE PARAPET (SINGLE FACE) (FOR TEMPORARY INSTALLATION ON BRIDGE DECK EXTERIOR)	502.12
MB-11A	TRAFFIC BARRIER SERVICE CONCRETE PARAPET (DOUBLE FACE) (FOR TEMPORARY INSTALLATION ON BRIDGE DECK EXTERIOR)	502.13
	TRAFFIC BARRIER SERVICE CONCRETE PARAPET (DOUBLE FACE) (FOR TEMPORARY INSTALLATION ON BRIDGE DECK EXTERIOR)	502.14
	TRAFFIC BARRIER SERVICE CONCRETE PARAPET (DOUBLE FACE) (FOR TEMPORARY INSTALLATION ON BRIDGE DECK EXTERIOR)	502.15
MB-12A, B, C	CONCRETE MEDIAN BARRIER (TALL WALL)	502.16
	CONCRETE MEDIAN BARRIER (TALL WALL)	502.17
MB-13	CONCRETE MEDIAN BARRIER TYPE I, II OR III	502.18
	CONCRETE MEDIAN BARRIER TYPE I, II OR III	502.19
MB-INS	PRECAST CONCRETE MEDIAN BARRIER POSITIVE CONNECTION OPTIONS	502.20
	PRECAST CONCRETE MEDIAN BARRIER POSITIVE CONNECTION OPTIONS	502.21
	PRECAST CONCRETE MEDIAN BARRIER POSITIVE CONNECTION OPTIONS	502.22
	BUTTING TRAFFIC BARRIER SERVICE TO SINGLE FACE PARAPET SERVICE	502.23
	BUTTING TRAFFIC BARRIER SERVICE TO SINGLE FACE PARAPET SERVICE	502.24
	STANDARD FENCE GENERAL NOTES	503.01
FE-W1, W2	STANDARD FENCE WOVEN WIRE FABRIC	503.02
FE-B	STANDARD FENCE BARBED WIRE	503.03
FE-CL	STANDARD FENCE CHAIN LINK	503.04
FE-G	STANDARD FENCE GATES	503.05
FE-4	WATER GATES IN FENCE LINES	503.06
FE-6	STANDARD METHOD OF FENCE AND HANDRAIL GROUNDING	503.07
RM-1	STANDARD PLAN AND METHOD OF SETTING RIGHT-OF-WAY MONUMENTS	504.01
RM-2	STANDARD PLAN AND METHOD OF SETTING RIGHT-OF-WAY MONUMENTS	504.02



ROAD AND BRIDGE STANDARDS

SHEET 2 OF 2

REVISION DATE

500.02

INDEX OF SHEETS

SECTION 500-GUARDRAIL, BARRIER AND FENCE

VIRGINIA DEPARTMENT OF TRANSPORTATION

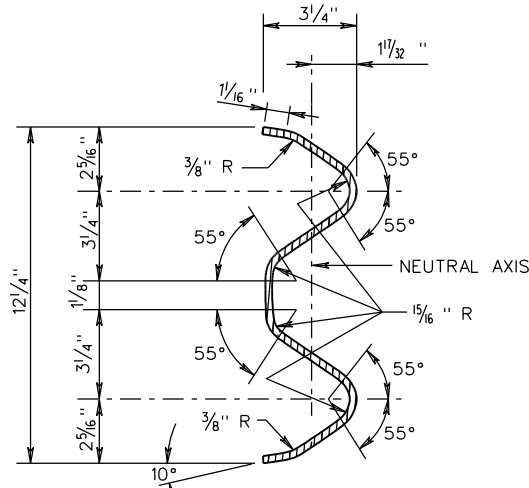

SECTION THRU RAIL ELEMENT AND W BEAM BACK-UP PLATE

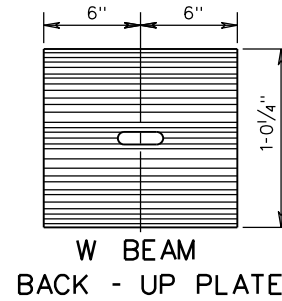

W BEAM BACK-UP PLATE

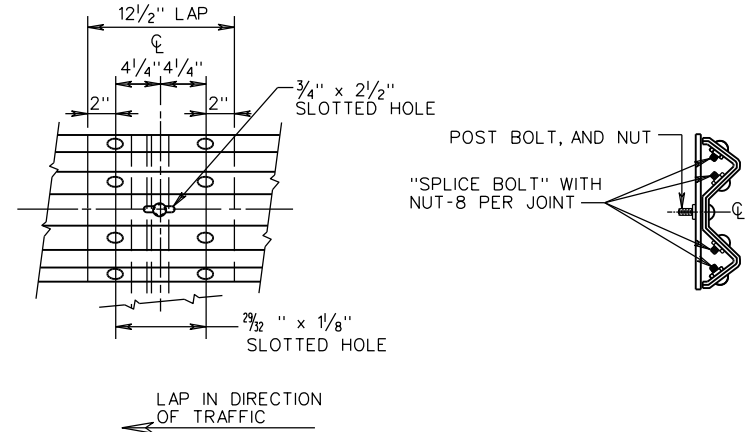

DETAIL OF SPLICE JOINT

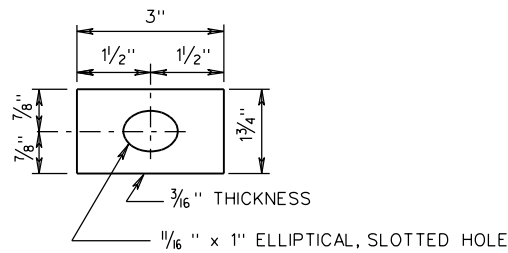

DETAIL OF STANDARD WASHER

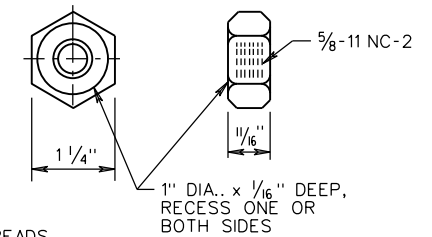
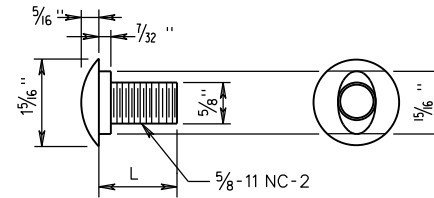

- L = 1 1/4" FOR SPLICE BOLT-FULL LENGTH THREADS
- L = 2" FOR SPLICE BOLT-FULL LENGTH THREADS ON NESTED W BEAMS.
- L = 10" FOR STEEL POST BOLT-1 1/2" MIN. THREADS
- L = 18" FOR WOOD AND CONCRETE POST BOLT-2 1/2" MIN. THREADS
- L = 26" FOR MB WOOD OR CONCRETE POST-2" MIN. THREADS

DETAIL OF BUTTON HEAD BOLT AND RECESS NUT (GUARDRAIL BOLT)

NOTES:

ALL HARDWARE IS TO BE GALVANIZED IN ACCORDANCE WITH THE SPECIFICATIONS.

THE GUARDRAIL AND MEDIAN BARRIER COMPONENTS DEPICTED IN ARTBA TECHNICAL BULLETIN NUMBER 268B MAY BE SUBSTITUTED IF INTERCHANGEABLE WITH THE STANDARDS FOR GUARDRAIL (GR) OR MEDIAN BARRIER (MB) AND APPROVED BY THE ENGINEER.

SPECIFICATION REFERENCE	<h1>STANDARD GUARDRAIL HARDWARE</h1>	VDOT ROAD AND BRIDGE STANDARDS	
221		REVISION DATE	SHEET 1 OF 3
505		01/14	501.01

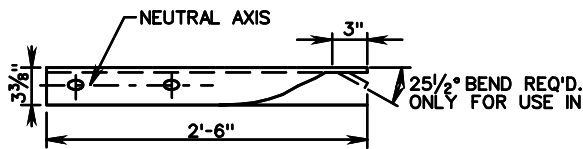

NOTE:
LAP IN DIRECTION OF
TRAFFIC AT SPLICE JOINT.

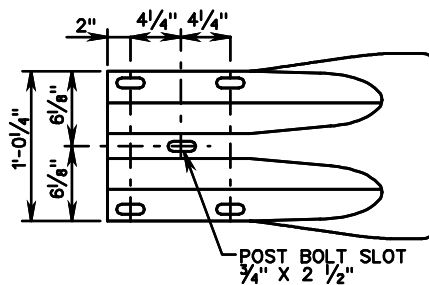
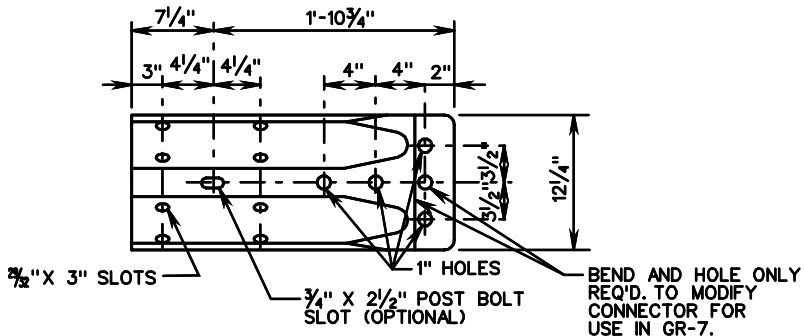
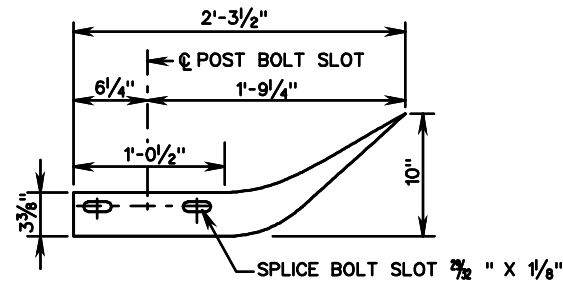

W BEAM TERMINAL CONNECTOR

W BEAM END SECTION (FLARED)

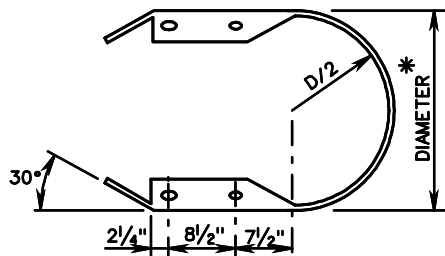

* THE GUARDRAIL MEDIAN BARRIER COMPONENTS DEPICTED IN A.R.T.B.A. TECHNICAL BULLETIN NUMBER 268B MAY BE SUBSTITUTED IF INTERCHANGEABLE WITH THE STANDARDS FOR GUARDRAIL (GR) OR MEDIAN BARRIER (MB) AND APPROVED BY THE ENGINEER.

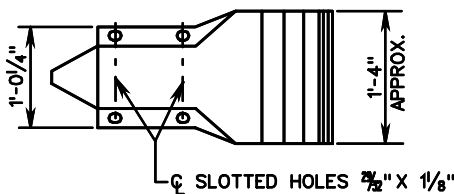
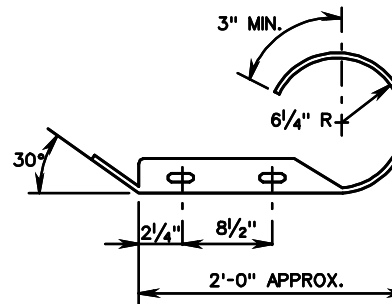

* STANDARD DIMENSIONS OF 12 1/2", 24" AND 30" ARE SUGGESTED.

W BEAM END SECTION (BUFFER)

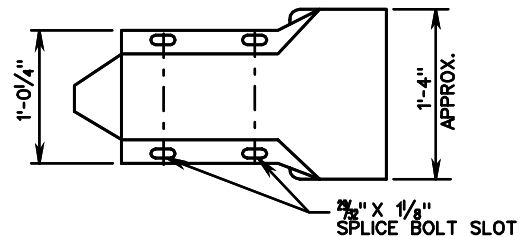

W BEAM END SECTION (ROUNDED)

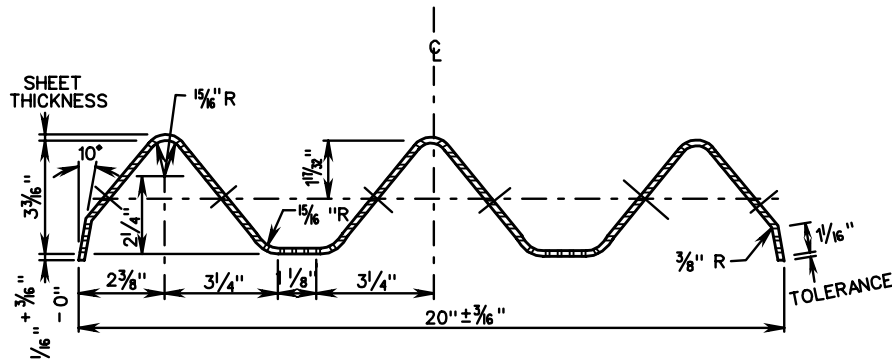

SECTION THRU THRIE BEAM RAIL ELEMENT

NOTES:

THE GUARDRAIL AND MEDIAN BARRIER COMPONENTS DEPICTED IN ARTBA TECHNICAL BULLETIN NUMBER 268B MAY BE SUBSTITUTED IF INTERCHANGEABLE WITH THE STANDARDS FOR GUARDRAIL (GR) OR MEDIAN BARRIER (MB) AND APPROVED BY THE ENGINEER.

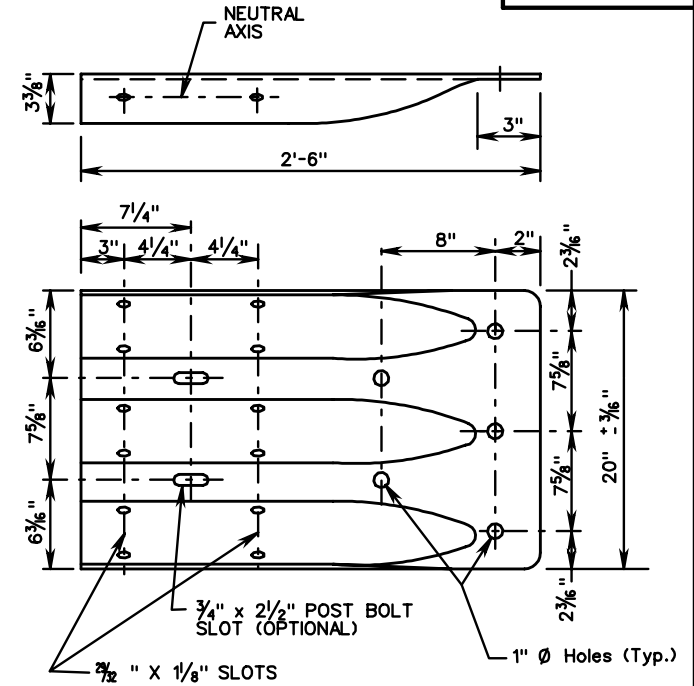

THRIE BEAM TERMINAL CONNECTOR DETAIL

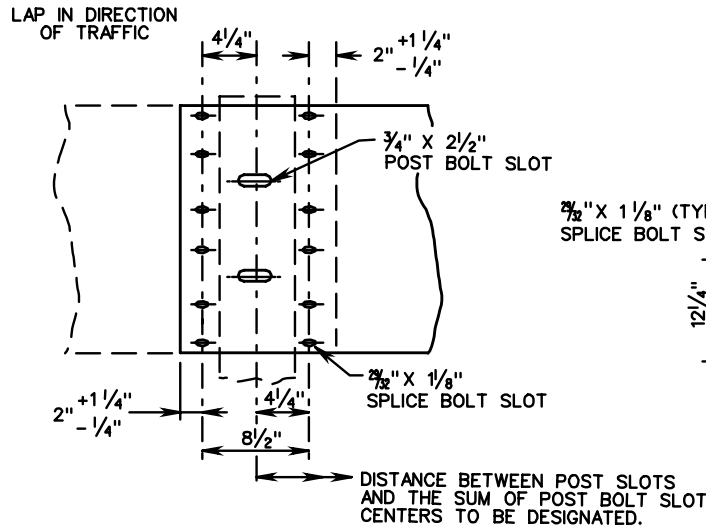

SPLICE DETAIL

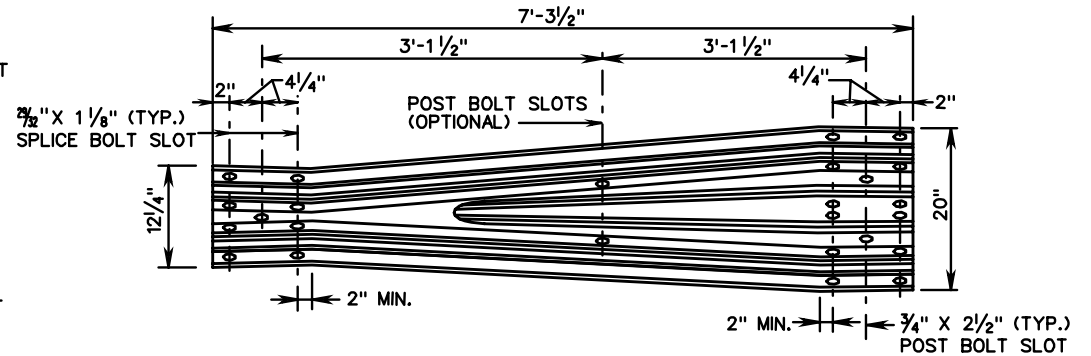

TRANSITION SECTION DETAIL (W-BEAM TO THRIE BEAM)

SPECIFICATION REFERENCE

221
505

STANDARD GUARDRAIL HARDWARE
THRIE BEAM GUARDRAIL HARDWARE

VIRGINIA DEPARTMENT OF TRANSPORTATION

VDOT

ROAD AND BRIDGE STANDARDS

REVISION DATE

SHEET 3 OF 3

501.03

* 27³/₄" MIN - 28³/₄" MAX RAIL HEIGHT

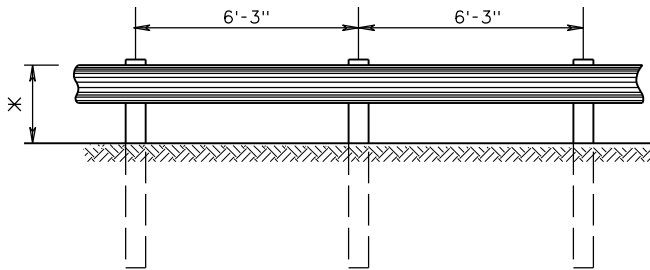

GR-2

(6'-3" POST SPACING)
MAX DYNAMIC DEFLECTION = 3'

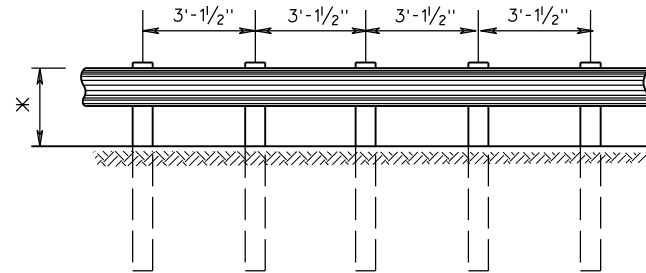

GR-2A

(3'-1/2" POST SPACING)
MAX DYNAMIC DEFLECTION = 2'

NOTES:

GUARDRAIL LOCATIONS SHOWN ON PLANS ARE APPROXIMATE ONLY AND CAN BE ADJUSTED DURING CONSTRUCTION IF AND AS DIRECTED BY THE ENGINEER.

FOR DETAILS OF POST AND BLOCKOUTS SEE SHEET NO. 501.05.

FOR DETAILS OF RAIL ELEMENT, RAIL SPLICE JOINT, AND ASSOCIATED HARDWARE SEE SHEET NOS. 501.01 AND 501.02.

RAIL ELEMENTS ARE FURNISHED SHOP CURVED FOR RADII BETWEEN 5 FEET AND 150 FEET.

ALL GUARDRAIL POSTS SHALL BE SET PLUMB. POST SHALL NOT BE SET WITH A VARIATION OF MORE THAN 1/8" PER FOOT FROM VERTICAL. W-BEAM, BLOCKOUTS, AND POSTS SHALL BE SET AND ALIGNED WITHOUT ALTERATION OR FORCE, AS PER SECTION 505 OF THE SPECIFICATIONS.

ALL GR-2 AND GR-2A RAIL SHALL BE MAINTAINED AT A HEIGHT OF 27³/₄" MIN - 28³/₄" MAX AS MEASURED PER STANDARD GR-INS.

ALL W-BEAM RAILS SHALL BE LAPPED IN THE DIRECTION OF VEHICULAR TRAVEL FOR THE FINISHED ROADWAY.

THE OPTIONAL GR-2A METHODS OF NESTING THE RAIL OR USE OF AN ADDITIONAL RAIL ON THE BACK OF THE POST FOR STANDARD GR-2A SHALL BE APPROVED BY THE ENGINEER PRIOR TO INSTALLATION.

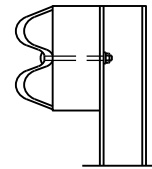

* OPTIONAL GR-2A METHOD USING NESTED RAIL

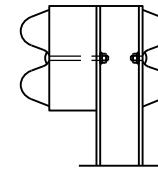

* OPTIONAL GR-2A METHOD USING ADDITIONAL RAIL ON BACK OF POST

* WHEN NESTED RAIL OR ADDITIONAL RAIL IS PLACED ON BACK OF POST FOR GR-2A THE POST SPACING WILL BE 6'-3".

DESIGN SPEED	FLARE RATES		
	INSIDE SHY LINE	BEYOND SHY LINE	
MPH	SHY LINE LS	FLARE RATE	FLARE RATE
70	9'	30:1	15:1 *
60	8'	26:1	14:1 *
50	6.5'	21:1	11:1 *
40	5'	16:1	8:1 *
30	4'	13:1	7:1 *

* SUGGESTED MAXIMUM FLARE RATE FOR SEMI-RIGID BARRIER SYSTEMS.



ROAD AND BRIDGE STANDARDS

A COPY OF THE ORIGINAL SEALED AND SIGNED DRAWING IS ON FILE IN THE CENTRAL OFFICE.
STANDARD BLOCKED-OUT W-BEAM GUARDRAIL
(STRONG POST SYSTEM)

VIRGINIA DEPARTMENT OF TRANSPORTATION

SPECIFICATION REFERENCE

221
505

SHEET 1 OF 2

REVISION DATE

501.04

08/14

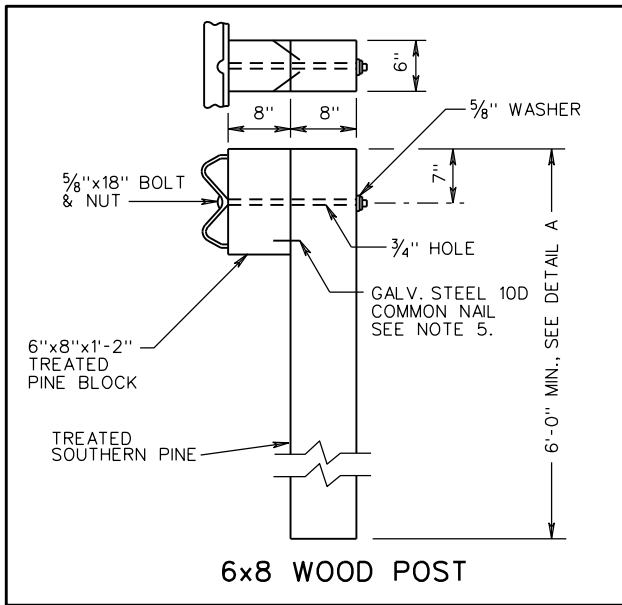

THE CRT POST IS FOR USE WITH THE STANDARD GR-10 TYPE III OR WHERE SPECIFIED BY THE ENGINEER IN THE PLANS.

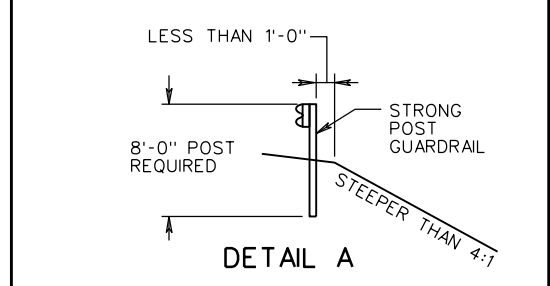
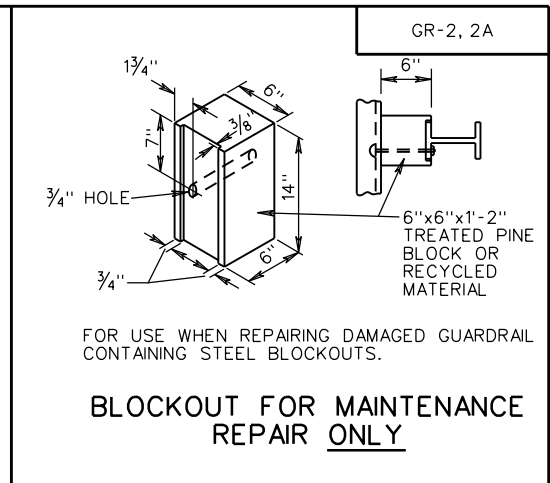
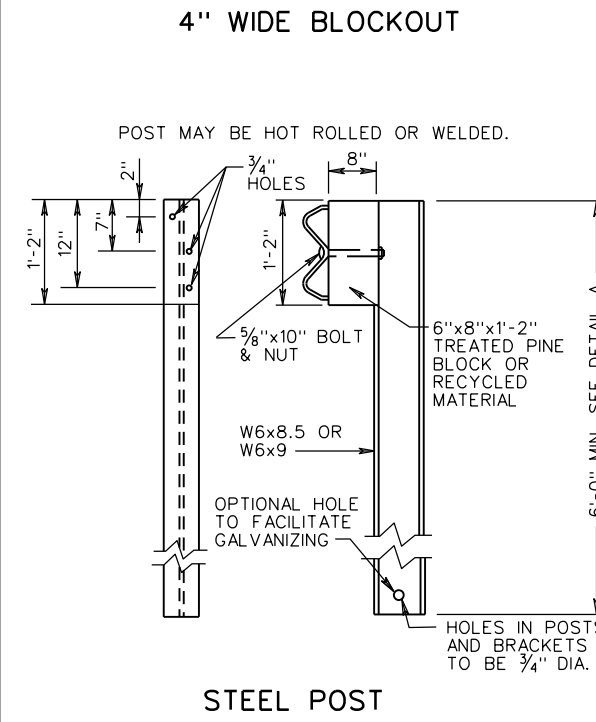
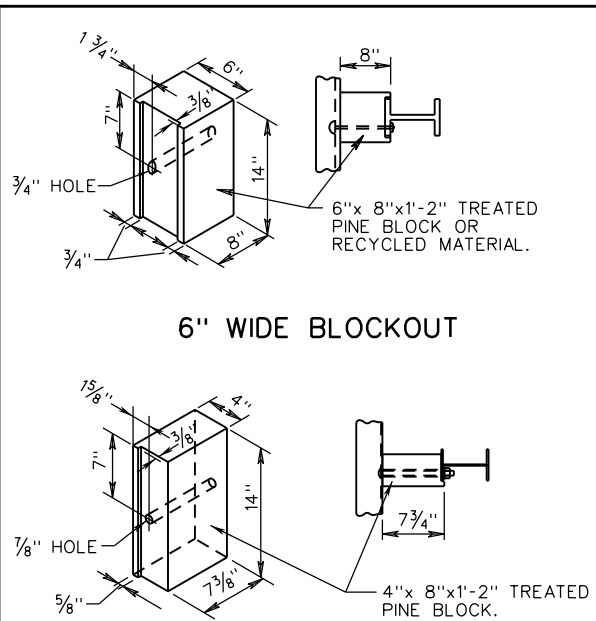
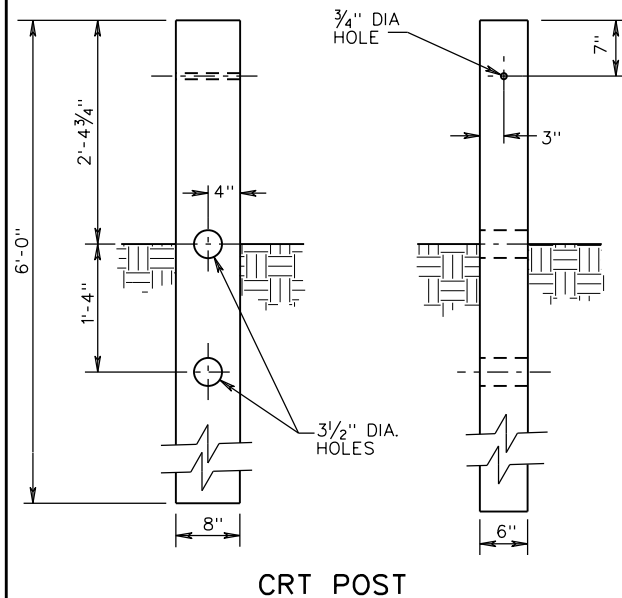

GUARDRAIL INSTALLATION SITES REQUIRING LONGER GUARDRAIL POSTS

- NOTES:
1. ALL BOLTS, NUTS, WASHERS, AND OTHER STEEL ITEMS ARE TO BE GALVANIZED.
 2. ALTERNATE TYPE POSTS AND BLOCKOUT MAY BE INTERCHANGED ON ANY ONE PROJECT WITH THE RESTRICTION THAT THE SAME TYPE OF POST AND BLOCKOUT MUST BE USED IN ANY SINGLE RUN OF GUARDRAIL.
 3. FOR DETAILS OF GUARDRAIL ELEMENT SPLICE JOINT, HARDWARE, ETC. SEE SHEET NOS. 501.01 AND 501.02.
 4. DRIVE NAIL ON BOTH SIDES WITHIN 2" OF THE TOP OR BOTTOM OF BLOCKOUT AFTER 5/8" x 18 BOLT IS INSTALLED.

SPECIFICATION REFERENCE
221
236
505

A COPY OF THE ORIGINAL SEALED AND SIGNED DRAWING IS ON FILE IN THE CENTRAL OFFICE.

STANDARD BLOCKED-OUT W-BEAM GUARDRAIL
(STRONG POST SYSTEM, POST AND BLOCKOUT DETAILS)

VIRGINIA DEPARTMENT OF TRANSPORTATION

VDOT ROAD AND BRIDGE STANDARDS	
REVISION DATE	SHEET 2 OF 2
08/14	501.05

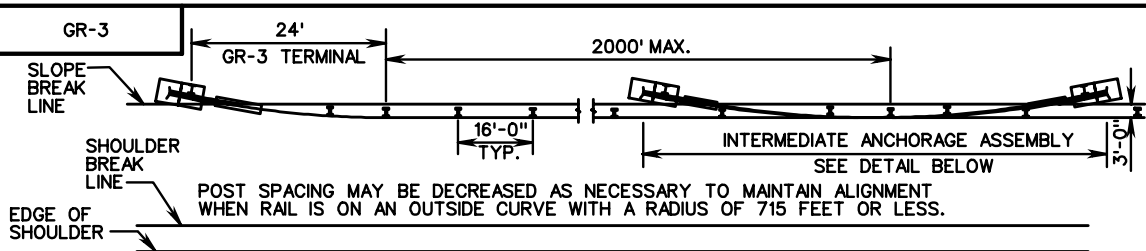

NOTES:

1. FOR ARRANGEMENTS OF SPRING CABLE END ASSEMBLIES (COMPENSATING DEVICES) AND TURNBUCKLE CABLE END ASSEMBLIES, THE FOLLOWING CRITERIA SHALL APPLY:
2. LENGTH OF CABLE RUNS:
 - TO 1000'-USE COMPENSATING DEVICE ON ONE END AND USE TURNBUCKLE ON THE OTHER END OF EACH INDIVIDUAL CABLE.
 - OVER 1000' TO 2000'-USE COMPENSATING DEVICE ON EACH END OF EACH INDIVIDUAL CABLE.
 - OVER 2000'-START NEW STRETCH BY INTERLACING AT LAST PARALLEL POST. SEE TYP. INSTALLATION.
3. FITTINGS: ALL FITTINGS SHALL BE SO DESIGNED AND BE OF SUCH SECTION AS TO DEVELOP THE FULL STRENGTH OF A SINGLE CABLE OR CABLE ASSEMBLIES, AS THE CASE MAY BE.
 - SINGLE CABLE ANCHOR ASSEMBLY- MIN. TENSILE STRENGTH.....25,000 LBS.
 - THREE CABLE ANCHOR ASSEMBLY- MIN. TENSILE STRENGTH.....100,000 LBS.
 - ALL FITTINGS SHALL BE HOT DIPPED GALVANIZED.
4. THE DYNAMIC DEFLECTION FOR STANDARD GR-3 IS 11 FEET.
5. FOR ROCK INSTALLATION, 8"x24"x1/4" PLATE SHALL BE ELIMINATED. DRILL OR EXCAVATE HOLE FOR POST AND BACKFILL WITH CRUSHER RUN AGGREGATE TO LEVEL OF ROCK.
6. 5/16" ANSIB18.2.2 HEX. BACKING NUT OR APPROVED SHOULDER MUST EQUAL BEARING AREA OF 5/16" STANDARD NUT.
7. THE GUARDRAIL AND MEDIAN BARRIER COMPONENTS DEPICTED IN AASHTO-AGC-ARTBA "A GUIDE TO STANDARDIZED HIGHWAY BARRIER HARDWARE" MAY BE SUBSTITUTED IF INTERCHANGEABLE WITH THE STANDARDS FOR GUARDRAIL (GR) OR MEDIAN BARRIER (MB) AND APPROVED BY THE ENGINEER.

TYPICAL INSTALLATION

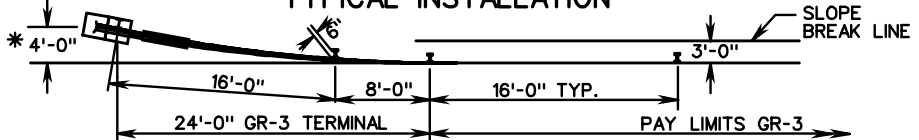

GUARDRAIL TERMINAL PLAN VIEW

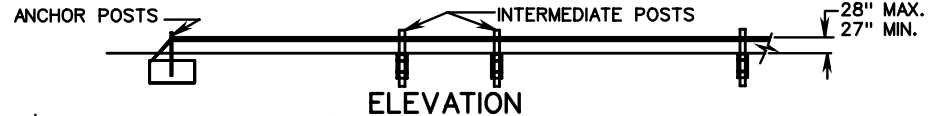

ELEVATION

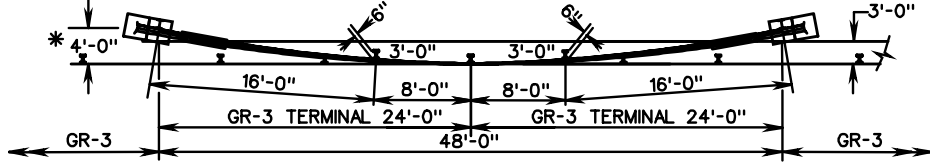

INTERMEDIATE ANCHORAGE PLAN VIEW

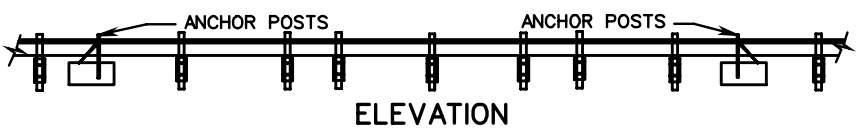

ELEVATION

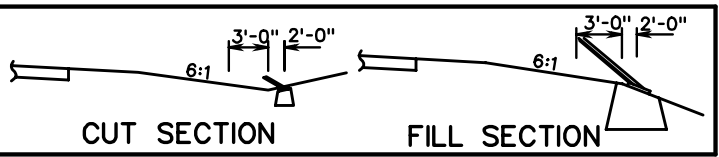

* WHEN BURYING GR-3 CABLE GUARDRAIL IN THE BACKSLOPE, THE CONCRETE ANCHOR ASSEMBLY MUST BE PLACED AT A HEIGHT ON THE BACKSLOPE TO MAINTAIN THE 27" MIN./28" MAX. CABLE HEIGHT AT THE ANCHORAGE.

CUT SECTION

FILL SECTION

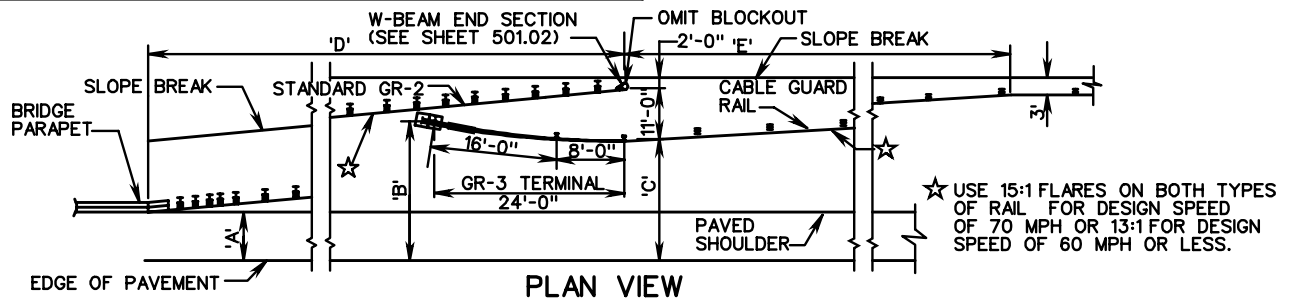

METHOD OF TRANSITION FROM CABLE GUARDRAIL TO W-BEAM GUARDRAIL AT BRIDGE APPROACHES

RECOVERABLE AREA WIDTH	LT. OR RT. OF C	70 MPH D.S.				
		A	B	C	D	E
24'	12'	27'	26'	375'	150'	
24'	6'	27'	26'	465'	150'	
21'	12'	24'	23'	330'	150'	
21'	6'	24'	23'	420'	150'	

☆ USE 15:1 FLARES ON BOTH TYPES OF RAIL FOR DESIGN SPEED OF 70 MPH OR 13:1 FOR DESIGN SPEED OF 60 MPH OR LESS.

VDOT
ROAD AND BRIDGE STANDARDS

SHEET 1 OF 3 REVISION DATE

501.06

CABLE GUARDRAIL

VIRGINIA DEPARTMENT OF TRANSPORTATION

SPECIFICATION REFERENCE

221
505

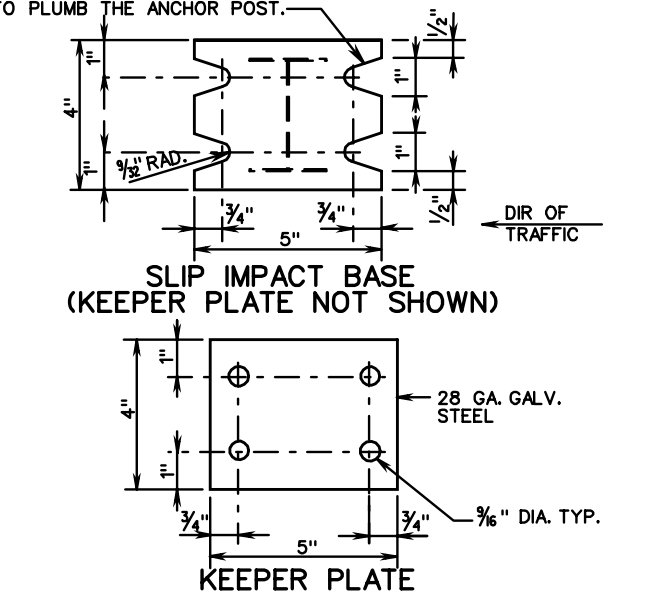
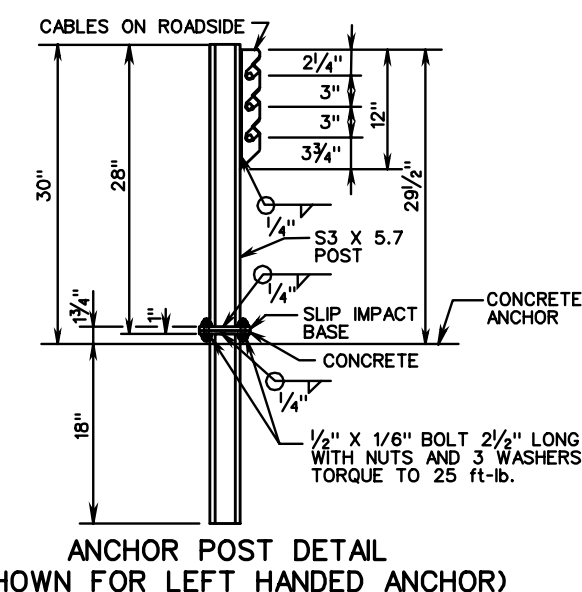
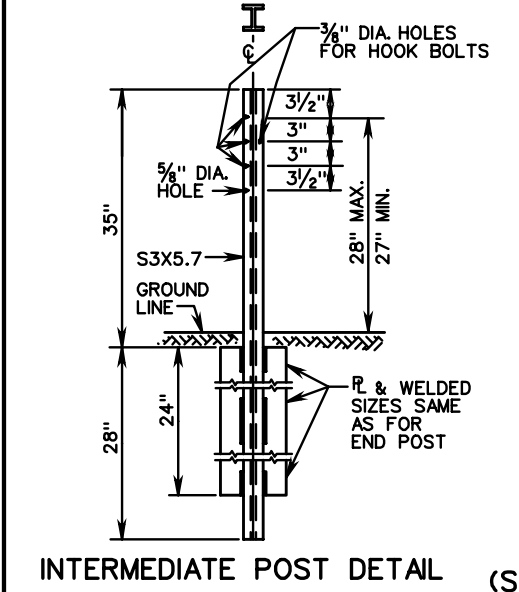
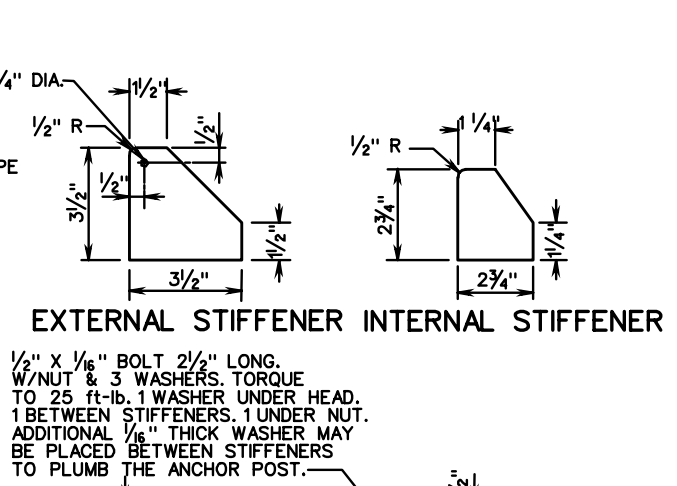
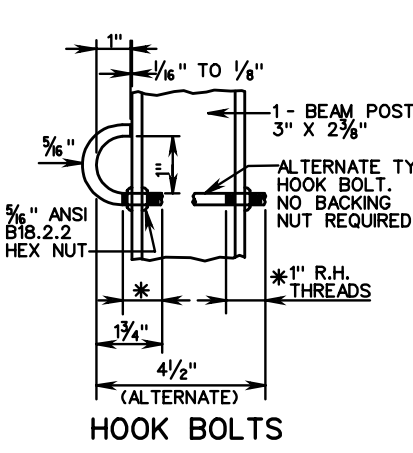
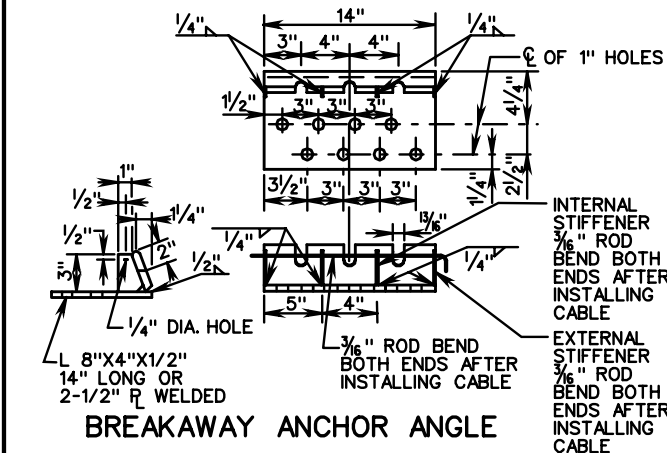
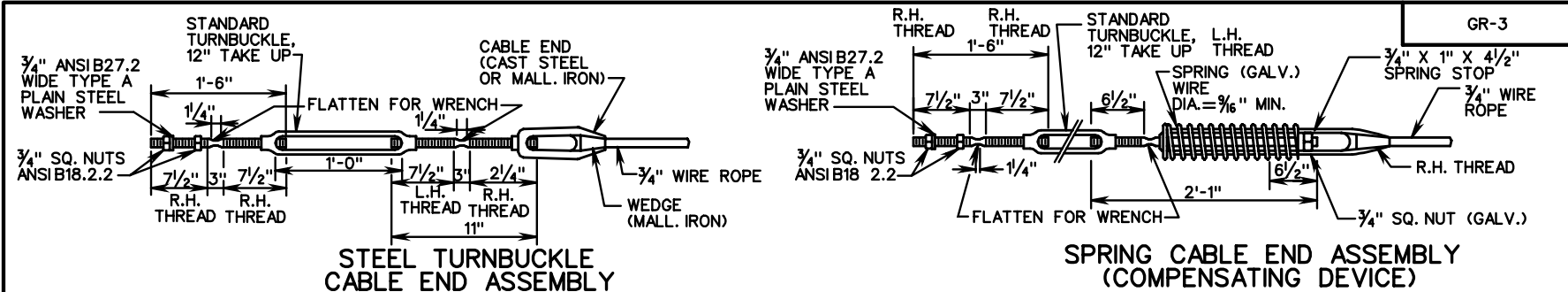

SPECIFICATION REFERENCE		CABLE GUARDRAIL		VDOT ROAD AND BRIDGE STANDARDS	
221 505					
VIRGINIA DEPARTMENT OF TRANSPORTATION		REVISION DATE	SHEET 2 OF 3		501.07

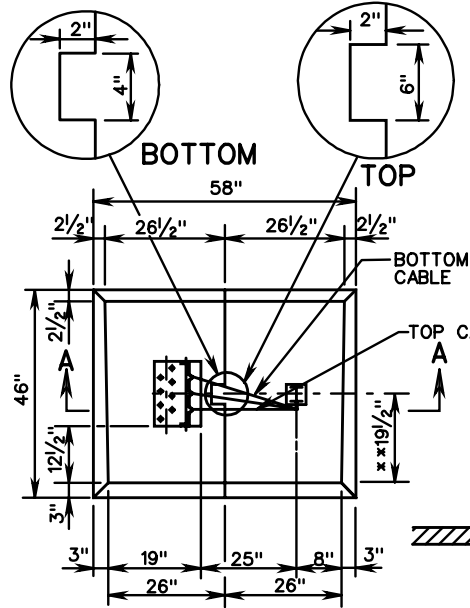

**ANCHOR UNIT DETAIL
TOP VIEW RIGHT HAND
(REINFORCEMENT NOT SHOWN)
TWO PIECE**

**ANCHOR UNIT DETAIL
TOP VIEW LEFT HAND
(REINFORCEMENT NOT SHOWN)**

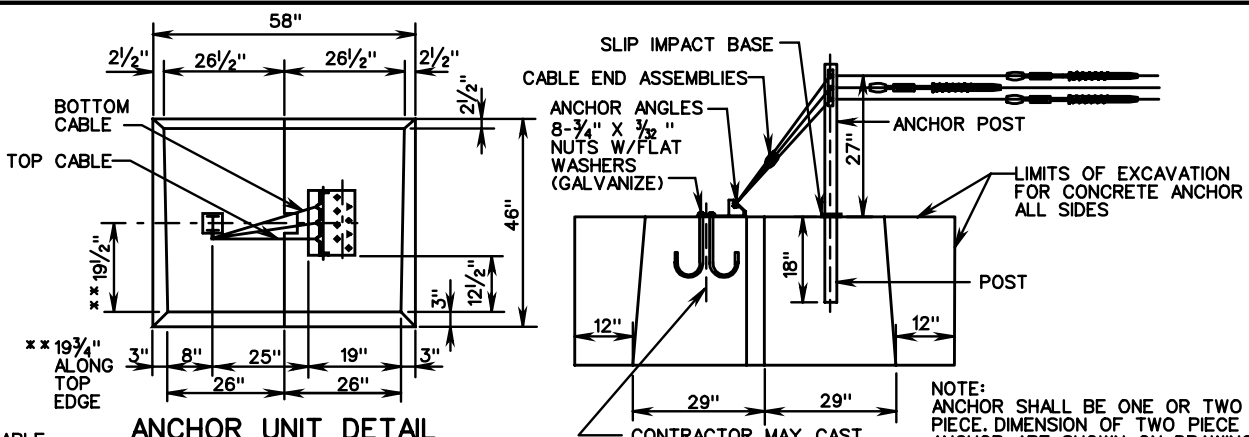

**SECTION AA
ANCHOR UNIT DETAIL
LEFT HAND
(REINFORCEMENT NOT SHOWN)**

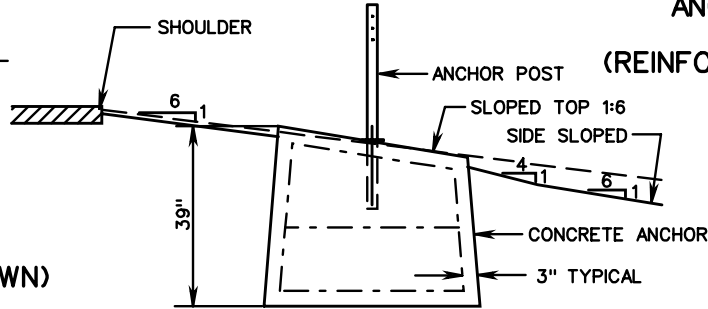

**ANCHOR UNIT DETAIL & RE-BAR
INSTALLATION DETAIL**

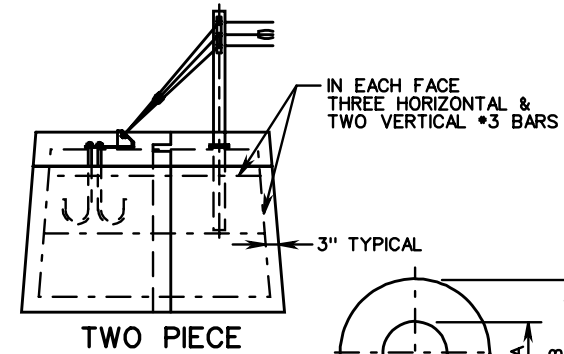

TWO PIECE

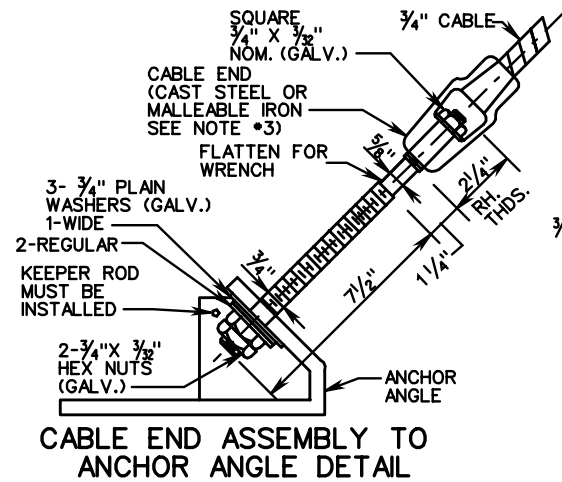

**CABLE END ASSEMBLY TO
ANCHOR ANGLE DETAIL**

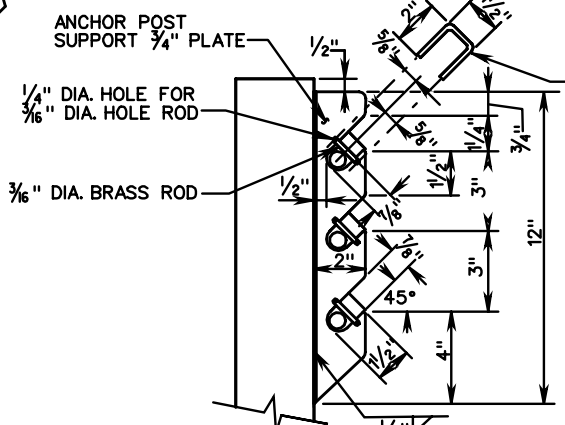

SIDE VIEW OF POST TOP

WASHER	WASHER SERIES	A		B		C	
		INSIDE DIA.	MIN.	MAX.	MIN.	MAX.	MIN.
3/4"	REGULAR	7/8"	55/64"	2"	1 15/16"	3/16"	9/64"
	WIDE	7/8"	55/64"	2 19/32"	2 35/64"	19/64"	5/32"
1/2"	NARROW	1 1/32"	1/2"	1"	63/64"	7/64"	1/16"

CABLE GUARDRAIL

SPECIFICATION REFERENCE

221
505

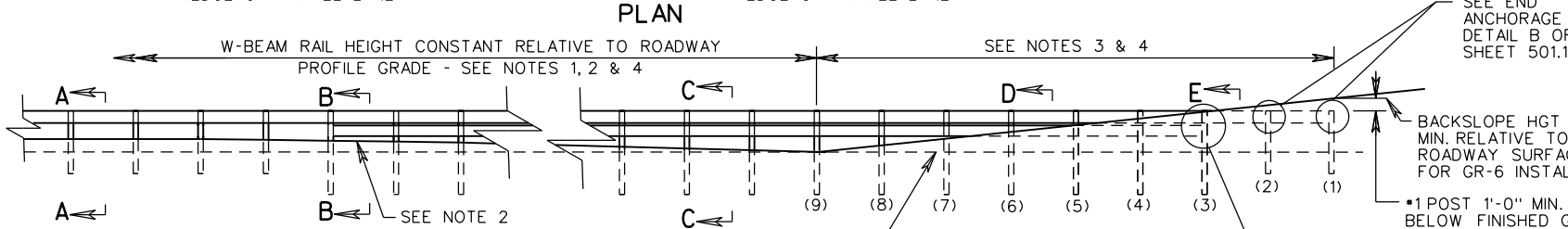
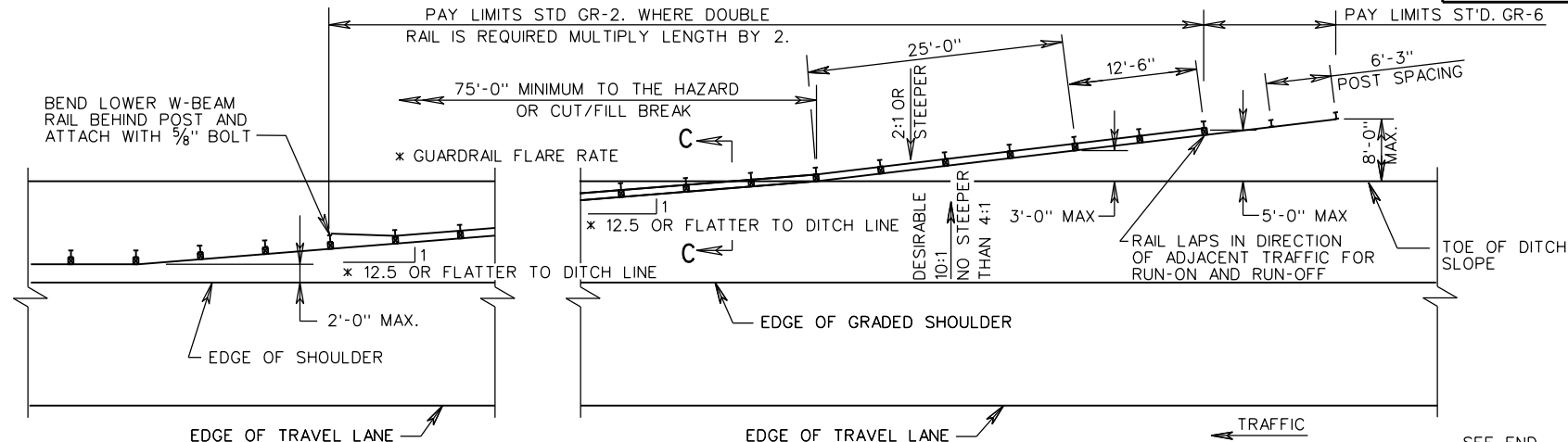

- NOTES:**
1. A SECOND RAIL IS REQ'D. WHERE THE DISTANCE BETWEEN THE GROUND AND BOTTOM OF THE TOP RAIL EXCEEDS 18" (UP TO THE POINT WHERE THE RAIL CROSSES THE DITCH LINE). THE DOUBLE RAIL WILL EXTEND TO POST #3.
 2. MAXIMUM DISTANCE BETWEEN BOTTOM OF THE LOWER W-BEAM RAIL AND GROUND LINE IS 18". WHEN DOUBLE RAIL IS REQ'D., TAPER BOTH W-BEAM RAILS TO MAINTAIN THE 18" DISTANCE FROM THE GROUND.
 3. BOTH W-BEAM RAILS TO BE 1'-0" BELOW FINISHED GRADE AT POST #1 (8'-0" OFFSET).
 4. A 8'-0" LONG POST MUST BE USED WHEN UPPER AND LOWER W-BEAM RAILS ARE REQUIRED. FROM THE BEGINNING OF THE LOWER RAIL THROUGH POST #3.
 5. STANDARD GR-6 TERMINAL TREATMENT MAY BE USED AT THE RUN-ON END OF DIVIDED HIGHWAYS (LEFT AND RIGHT OF TRAFFIC) AND AT THE RUN-ON AND RUN-OFF ENDS ON UNDIVIDED HIGHWAYS.
 6. ALL POST SPACING 6'-3" C-C UNLESS OTHERWISE NOTED. THE POST MAY BE W6 X 8.5 STEEL OR 6 X 8 WOOD EXCEPT THE LAST 3 TERMINAL POSTS MUST BE W6 X 8.5 STEEL.
 7. FOR SECTIONS D-D & E-E, AND END ANCHORAGE DETAILS SEE SHEET 501.10.
 8. ALL TERMINAL RUN-ON OR RUN-OFF INSTALLATIONS SHALL BE INSTALLED WITH RAILS LAPPED IN THE DIRECTION OF ADJACENT TRAFFIC.
 9. IF THE BACKSLOPE IS ROCK AND 1:1 OR STEEPER, THE W-BEAM MAY BE ANCHORED PER SOLID ROCK CUT INSTALLATION (DETAIL F).

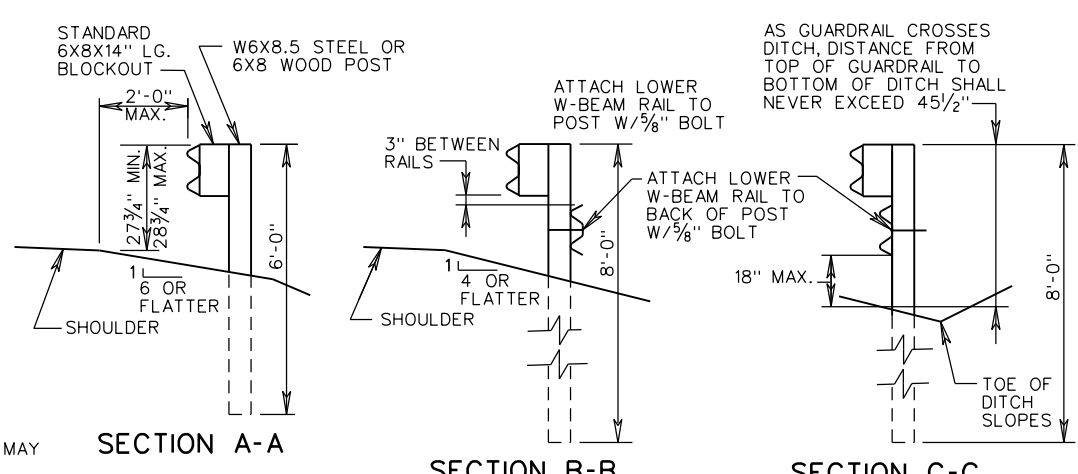

SPECIFICATION REFERENCE
221 505

A COPY OF THE ORIGINAL SEALED AND SIGNED DRAWING IS ON FILE IN THE CENTRAL OFFICE.

TERMINAL TREATMENT FOR W-BEAM GUARDRAIL

VIRGINIA DEPARTMENT OF TRANSPORTATION

VDOT	
ROAD AND BRIDGE STANDARDS	
REVISION DATE	SHEET 1 OF 2
7/12	501.09

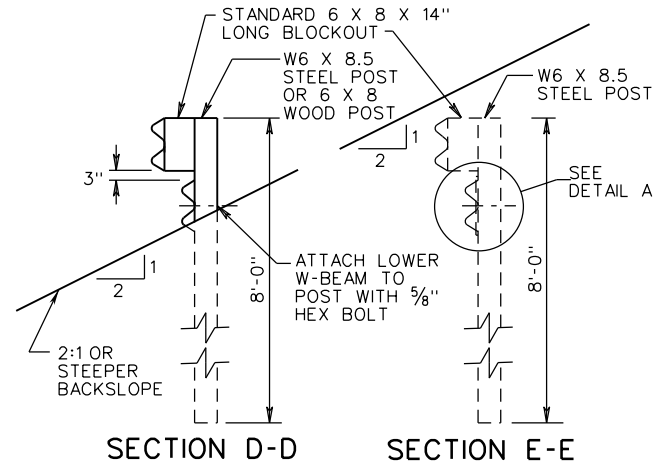
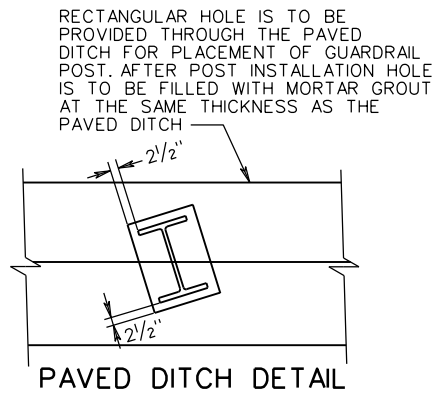
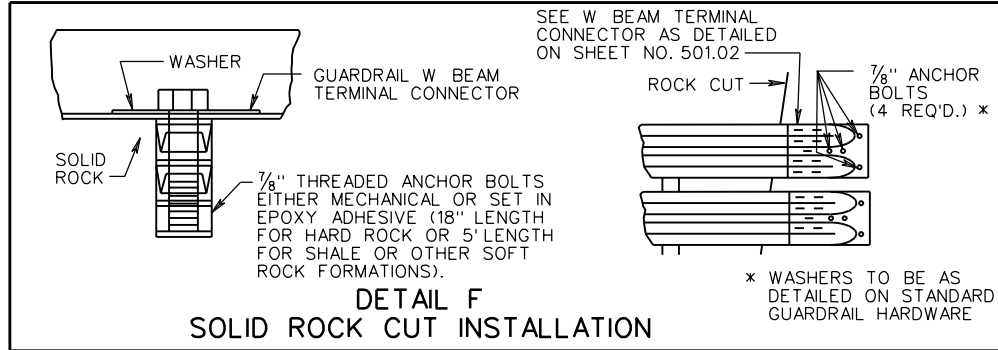
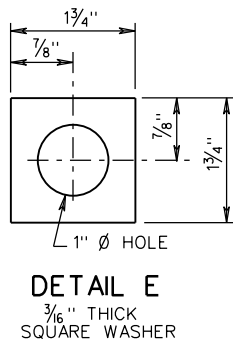
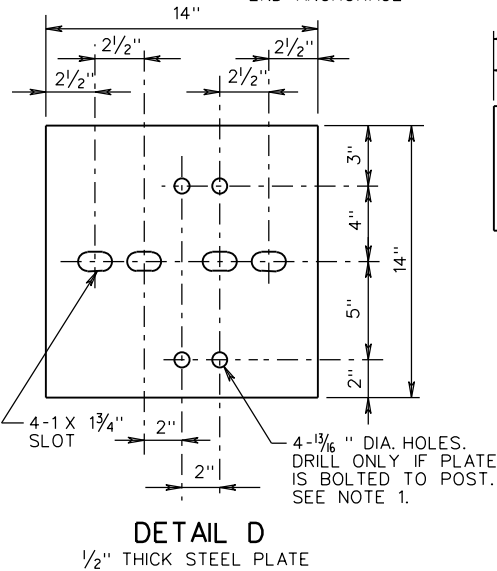
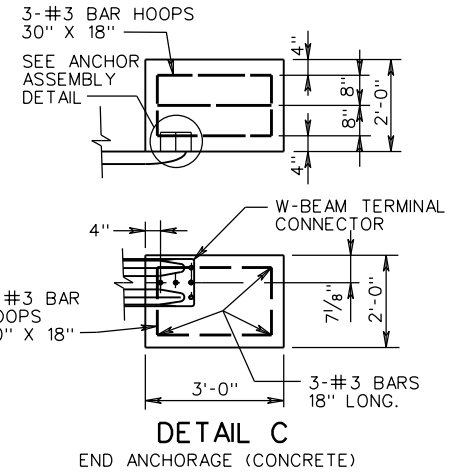
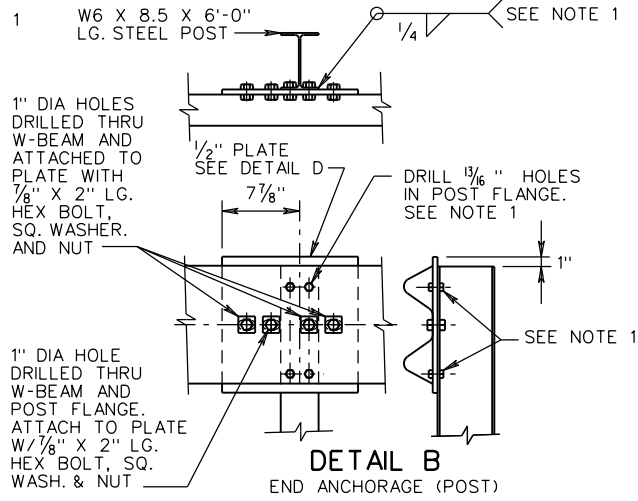
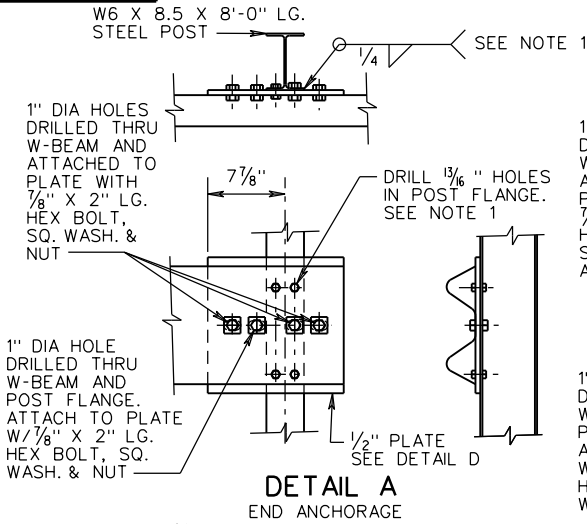

- NOTE:**
- 1/2" STEEL PLATE MAY BE WELDED OR BOLTED TO POST. IF PLATE IS BOLTED TO POST USE 4 - 3/8" X 1 1/2" LG. HEX HEAD BOLTS W/ HEX NUTS. IF PLATE IS WELDED TO POST DO NOT DRILL 13/16" HOLES IN PLATE OR IN POST FLANGES.
 - CONCRETE END ANCHORAGE MAY BE USED IN PLACE OF STEEL POST AT 8'-0" OFFSET.



ROAD AND BRIDGE STANDARDS

SHEET 2 OF 2

REVISION DATE

501.10

7/12

A COPY OF THE ORIGINAL SEALED AND SIGNED DRAWING IS ON FILE IN THE CENTRAL OFFICE.

TERMINAL TREATMENT FOR W-BEAM GUARDRAIL

VIRGINIA DEPARTMENT OF TRANSPORTATION

SPECIFICATION REFERENCE

221

505

NOTES:

1. GUARDRAIL TERMINAL, STD. GR-7 IS TO BE SRT 350 (SIMILAR TO AS SHOWN) MANUFACTURED BY TRINITY INDUSTRIES, THE FLEAT 350 MANUFACTURED BY ROAD SYSTEMS, INC., OR OTHER VDOT APPROVED EQUAL MEETING NCHRP 350 TESTING CRITERIA.
2. ALL TERMINALS SHALL BE INSTALLED ACCORDING TO THE MANUFACTURER'S INSTALLATION INSTRUCTIONS AND THE FOLLOWING VDOT REQUIREMENTS:
 - A. ALL STANDARD GR-7 TERMINALS SHALL BE INSTALLED WITH A 4 FT. OFFSET.
 - B. YELLOW 8" X 36" REFLECTIVE SHEETING, IN ACCORDANCE WITH VDOT SPECIFICATIONS, SHOULD BE APPLIED IN TERMINALS EMPLOYING W-BEAM END SECTIONS. FOR TERMINALS EMPLOYING IMPACT (EXTRUDER) HEADS, AMBER (YELLOW) REFLECTIVE SHEETING WITH BLACK DIAGONAL STRIPES SHOULD BE APPLIED TO THE FULL AREA INSIDE THE IMPACT HEAD WITH THE DIRECTION OF THE BLACK DIAGONAL STRIPES CONFORMING TO CURRENT MUTCD APPLICATION FOR TYPE 3 OBJECT MARKERS (OM-3).
 - C. DO NOT CHANGE THE LAPPING OF TERMINAL FOR ANY INSTALLATIONS. INSTALL AS SHOWN BELOW REGARDLESS OF ADJACENT TRAFFIC DIRECTION.
 - D. HEIGHT MEASURED AT TOP OF W-BEAM IS 27 $\frac{3}{4}$ " MIN. - 28 $\frac{3}{4}$ " MAX.
3. IF YOU CANNOT GET THE NECESSARY CLEAR RUNOUT AREA FOR THE GR-7 TERMINAL, CONSIDER ALTERNATIVE TERMINAL OPTIONS.
4. THIS DRAWING IS REPRESENTATIONAL ONLY. DETAILS, DIMENSIONS, QUANTITIES, AND OTHER INFORMATION NOT SHOWN WILL VARY FOR EACH MANUFACTURER. SEE INDIVIDUAL MANUFACTURER'S PLANS FOR THIS INFORMATION.

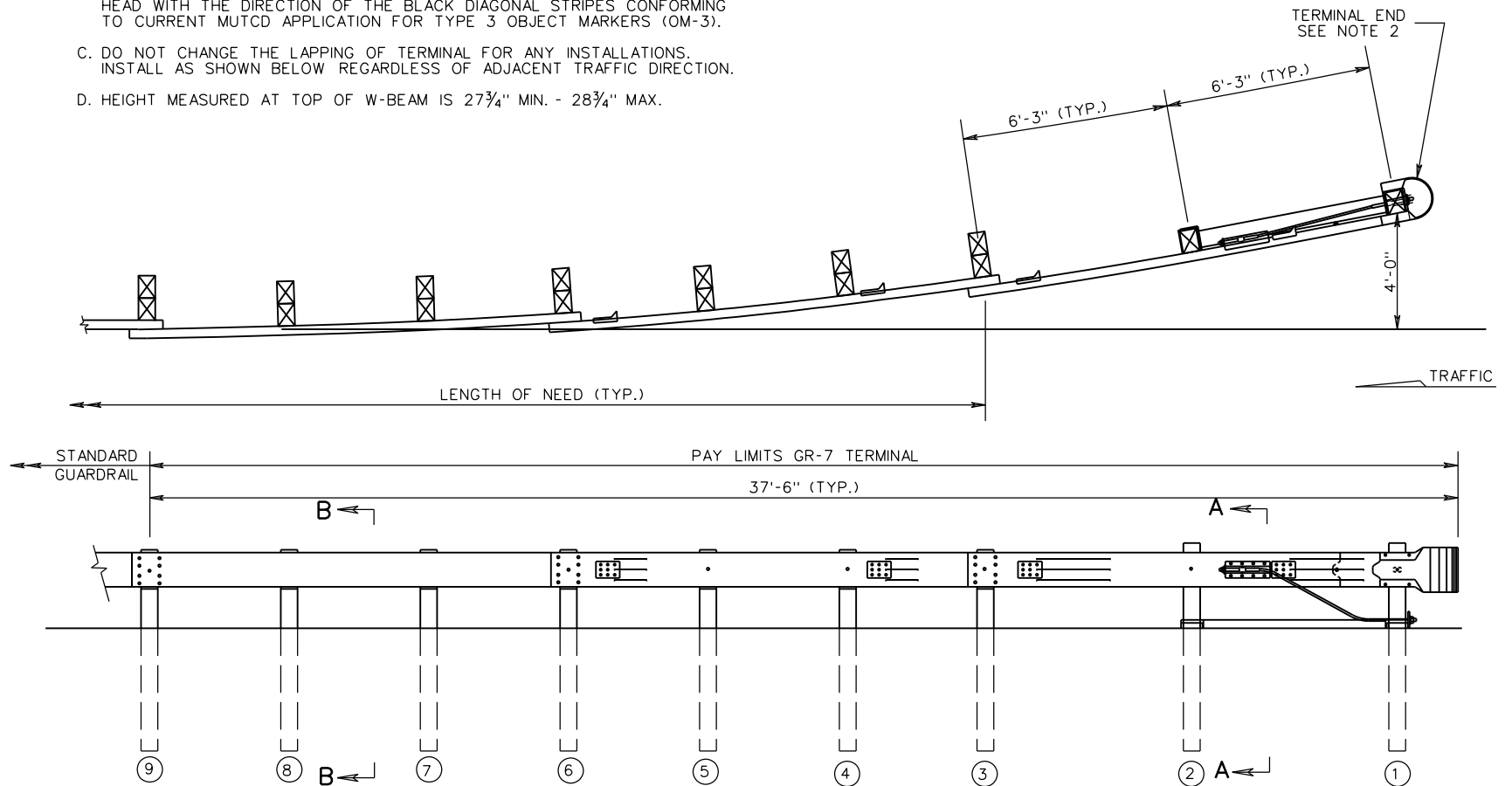

SPECIFICATION REFERENCE

221
505

A COPY OF THE ORIGINAL SEALED AND SIGNED DRAWING IS ON FILE IN THE CENTRAL OFFICE.

BREAKAWAY CABLE TERMINAL (4' FLARE)

VIRGINIA DEPARTMENT OF TRANSPORTATION

VDOT

ROAD AND BRIDGE STANDARDS

REVISION DATE

07/12

SHEET 1 OF 3

501.11

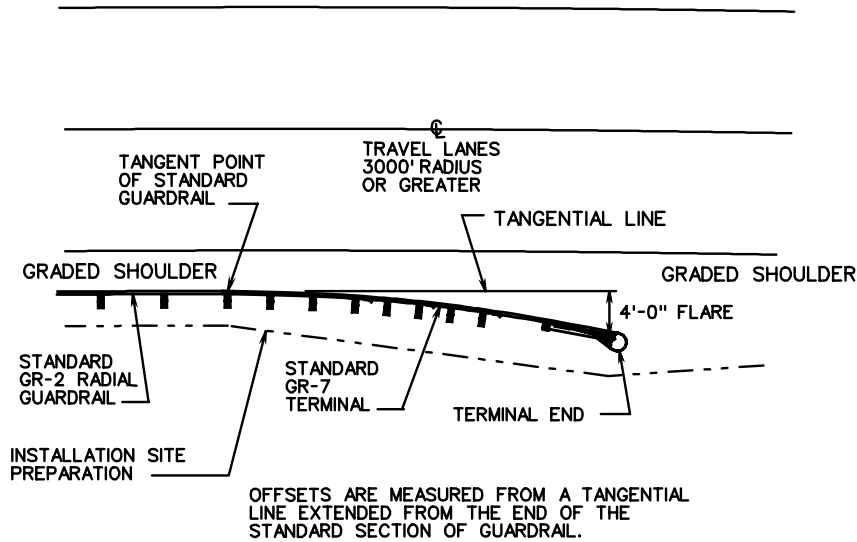

**FLARED TERMINAL PLACEMENT
3000 FT. RADIUS OR GREATER**

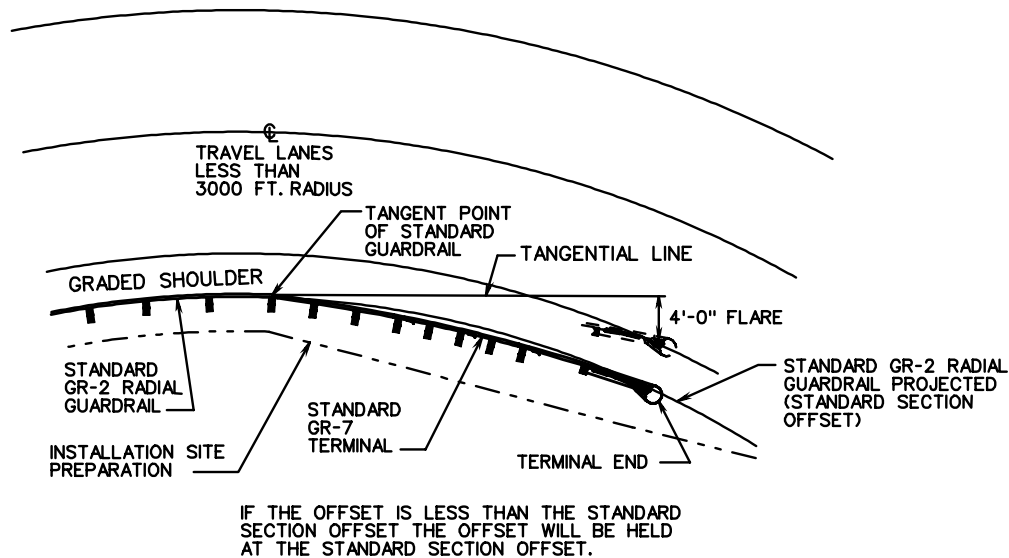

**FLARED TERMINAL PLACEMENT ON
INSIDE OF CURVE - LESS THAN
3000 FT. RADIUS**



ROAD AND BRIDGE STANDARDS

SHEET 2 OF 3

REVISION DATE

501.12

**BREAKAWAY CABLE TERMINAL
(4' FLARE)**

VIRGINIA DEPARTMENT OF TRANSPORTATION

SPECIFICATION
REFERENCE

221
505

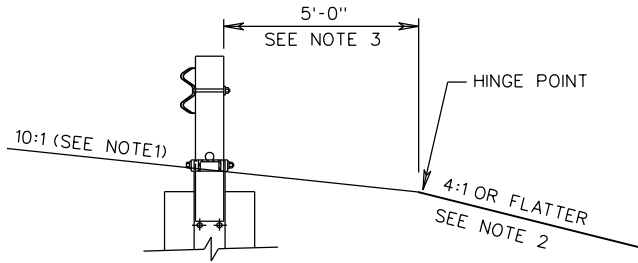

SECTION A-A

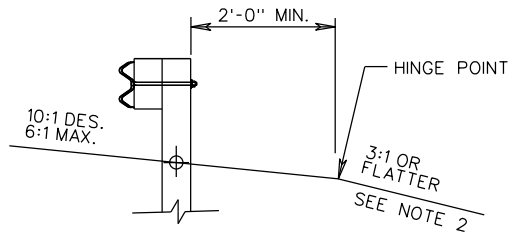

SECTION B-B

NOTES:

1. THE CROSS SLOPE OF THE GRADE APPROACHING THE GUARDRAIL TERMINAL, AND ADJACENT TO FOR ITS FULL LENGTH, MUST BE 10:1. IF THE EXISTING GRADE IS FLAT OR IS A POSITIVE SLOPE DUE TO THE SUPERELEVATION OF THE ROADWAY PAVEMENT, THE MIN. OFFSET FROM BEHIND THE POST TO THE HINGE POINT, AS SHOWN, IS REQUIRED.
2. THE AREA IMMEDIATELY BEHIND AND BEYOND THE TERMINAL SHOULD BE TRAVERSABLE (3:1 OR FLATTER) AND FREE FROM FIXED OBJECTS. IF A CLEAR RUN OUT IS NOT ATTAINABLE THIS AREA SHOULD AT LEAST BE SIMILAR IN CHARACTER TO THE UPSTREAM UN-SHIELDED ROADSIDE AREAS.
3. FOR NEW CONSTRUCTION, RECONSTRUCTION, AND 3R WORK THE 10:1 SLOPE GRADING MUST EXTEND A MINIMUM OF 5'-0" BEHIND THE END POST.
4. FOR PROPRIETARY GUARDRAIL TERMINALS THE MANUFACTURER'S SITE PREPARATION REQUIREMENTS TAKE PRECEDENCE OVER THIS STANDARD.

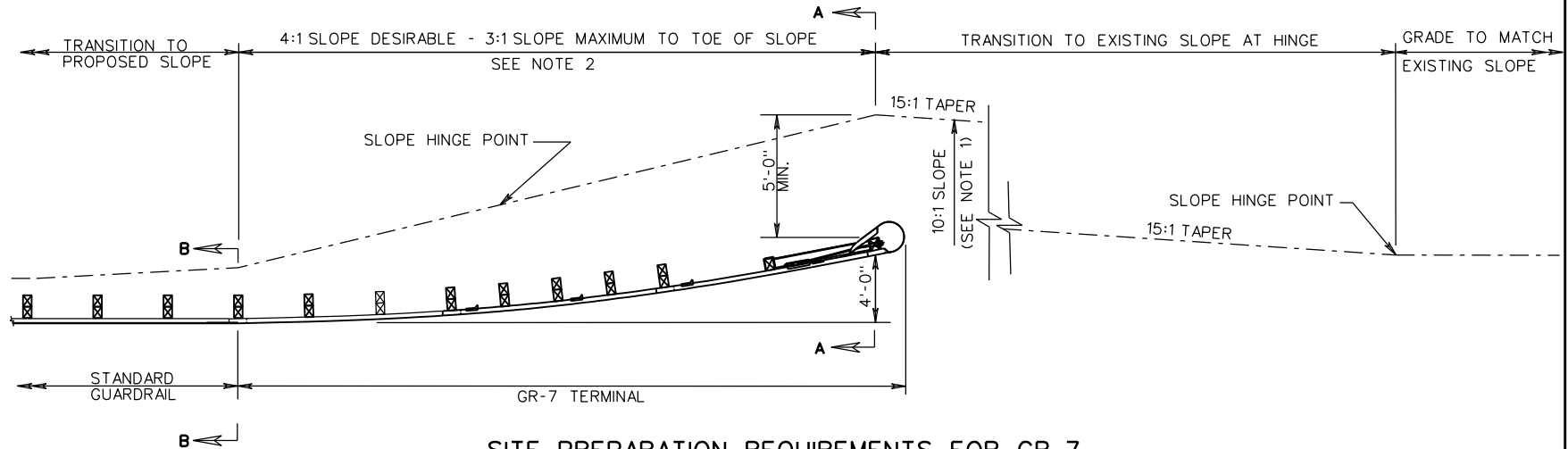

SITE PREPARATION REQUIREMENTS FOR GR-7

SPECIFICATION REFERENCE

221
505

A COPY OF THE ORIGINAL SEALED AND SIGNED DRAWING IS ON FILE IN THE CENTRAL OFFICE.
GUARDRAIL TERMINAL INSTALLATION SITE PREPARATION REQUIREMENTS FOR GR-7

VIRGINIA DEPARTMENT OF TRANSPORTATION

VDOT

ROAD AND BRIDGE STANDARDS

REVISION DATE

01/14

SHEET 3 OF 3

501.13

GR-8,8A,8B,8C

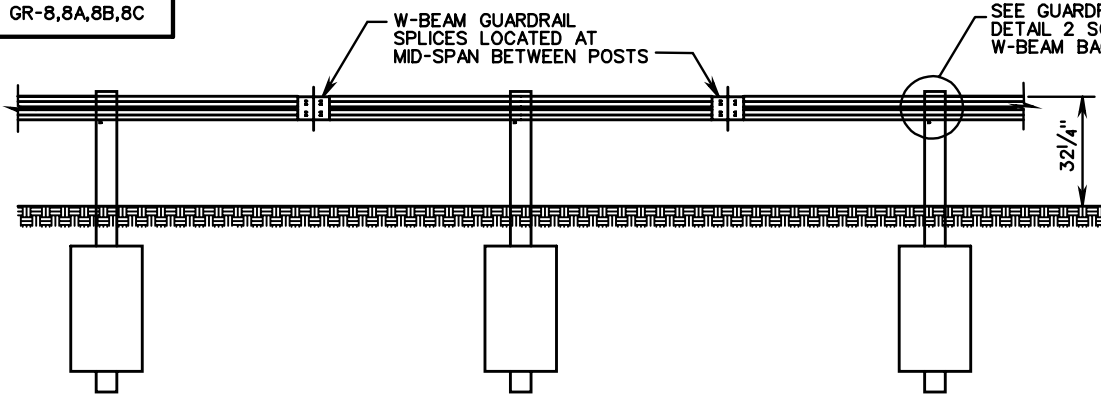

TYPICAL INSTALLATION

STANDARD	POST SPACING	DEFLECTION
GR-8	12' - 6"	7' - 0"
GR-8A	6' - 3"	5' - 0"
GR-8B	3' - 1/2"	4' - 0"
GR-8C	4' - 2"	4' - 6"

FOR ROCK INSTALLATION, 8" X 24" X 1/4" PLATE IS TO BE ELIMINATED. DRILL OR EXCAVATE HOLE FOR POST, PLACE POST AND BACKFILL WITH CRUSHER RUN AGGREGATE TO LEVEL OF ROCK.

ALL POSTS, BOLTS, NUTS AND WASHERS ARE TO BE GALVANIZED.

FOR DETAILS OF GUARDRAIL ELEMENT, SPLICE JOINT, HARDWARE, ETC. SEE SHEET NO. 501.01.

⊗ THE GUARDRAIL AND MEDIAN BARRIER COMPONENTS DEPICTED IN A.R.T.B.A. TECHNICAL BULLETIN NUMBER 268B MAY BE SUBSTITUTED IF INTERCHANGEABLE WITH THE STANDARDS FOR GUARDRAIL (GR) OR MEDIAN BARRIER (MB) AND APPROVED BY THE ENGINEER.

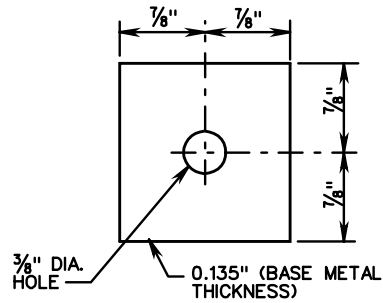

SQUARE WASHER

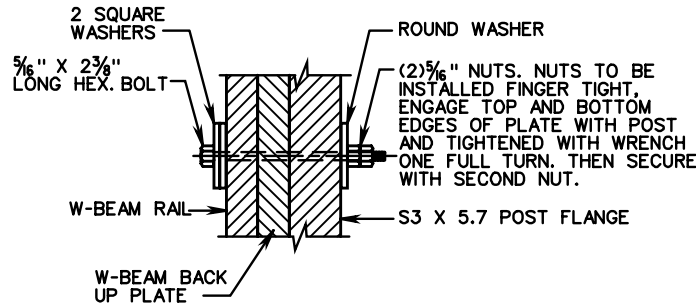

GUARDRAIL POST CONNECTION DETAIL

POST SPACING ON CURVES	
PAVEMENT ϕ RADIUS	POST SPACING
> 220 FT. R	12' - 6"
219 FT. - 111 FT.	6' - 3"
110 FT. - 76 FT.	4' - 2"
75 FT. - 50 FT.	3' - 1/2"
< 50 FT.	USE NOT RECOMMENDED

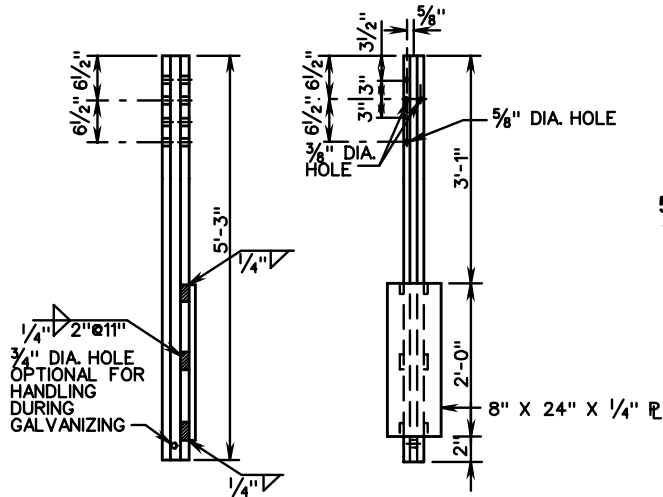

S 3 X 5.7 STEEL POST

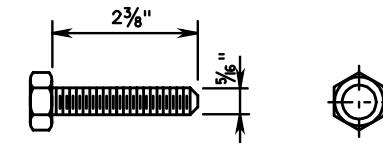

5/16" HEX BOLT AND NUT

BOLT AND NUT SHALL HAVE 4000 POUNDS MIN. TENSILE STRENGTH

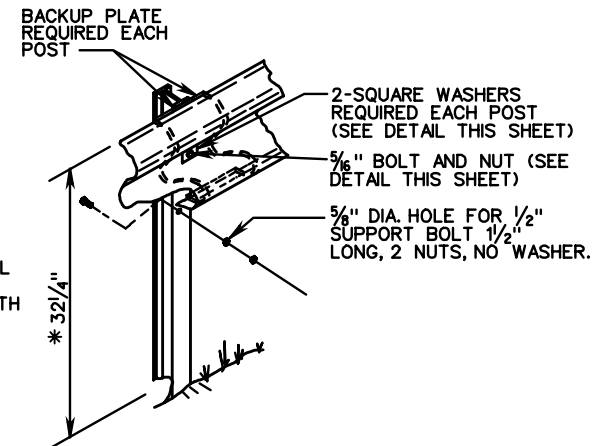

TYPICAL INSTALLATION

* HEIGHT TOLERANCE \pm 3/4"

VDOT

ROAD AND BRIDGE STANDARDS

STANDARD W-BEAM GUARDRAIL (WEAK POST SYSTEM)

SPECIFICATION REFERENCE

SHEET 1 OF 2

REVISION DATE

TL-3 (>45 MPH)

221
505

501.14

VIRGINIA DEPARTMENT OF TRANSPORTATION

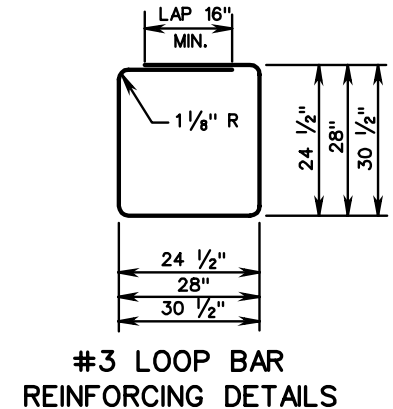
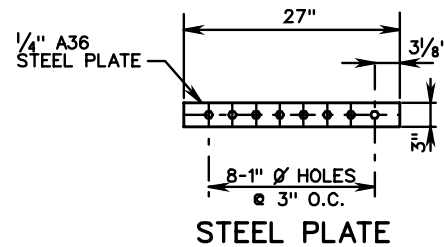
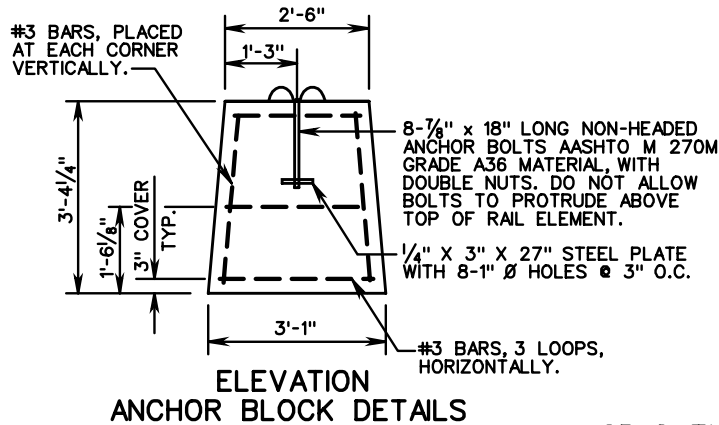
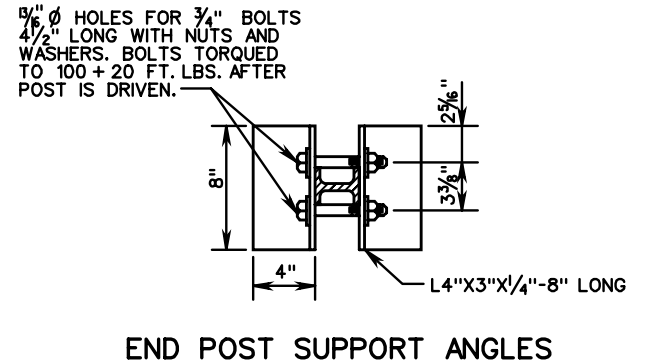
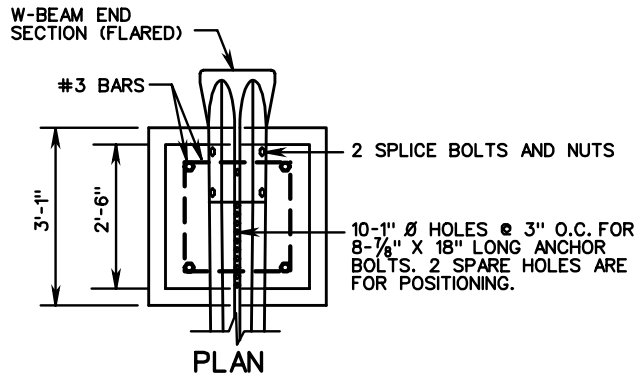
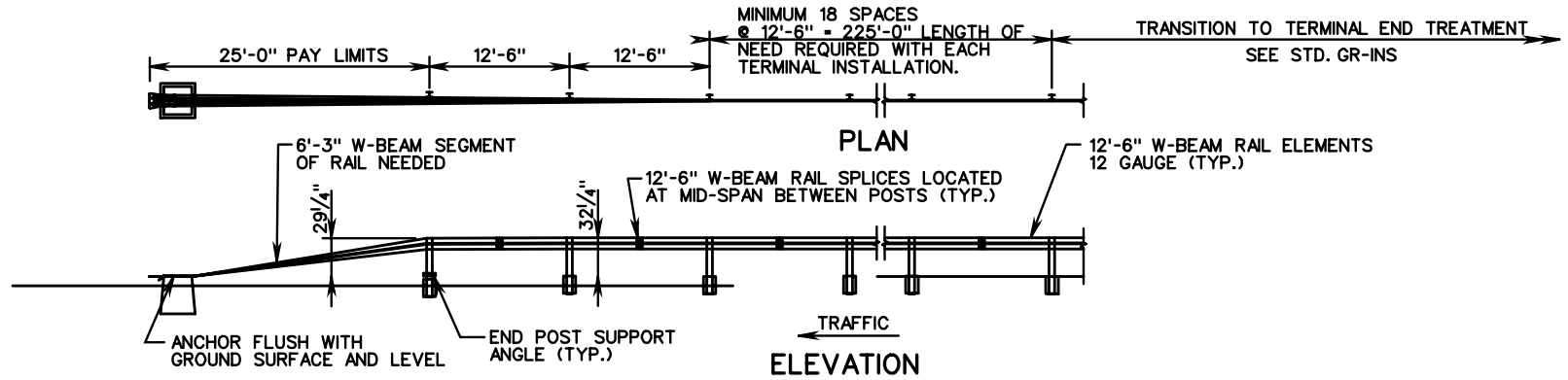

GR-8 TYPE II TERMINAL TREATMENT
(RUN-OFF ANCHORAGE)

SPECIFICATION REFERENCE 221 505	STANDARD W-BEAM GUARDRAIL (WEAK POST SYSTEM) TL-3 (>45 MPH) VIRGINIA DEPARTMENT OF TRANSPORTATION	VDOT ROAD AND BRIDGE STANDARDS	
		REVISION DATE	SHEET 2 OF 2 501.15

GR-9

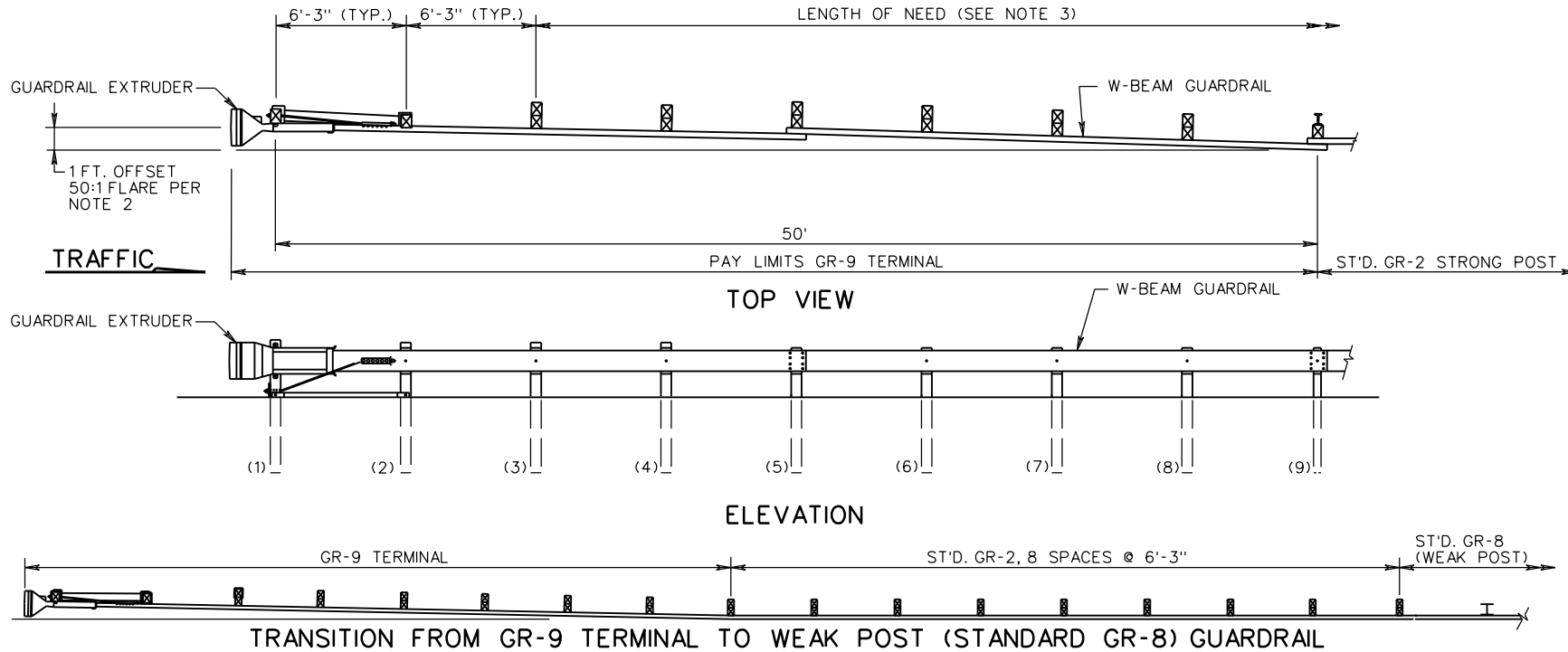

NOTES:

1. ALTERNATE BREAKAWAY CABLE TERMINAL (GR-9) SHALL BE A VDOT APPROVED PRODUCT MEETING NCHRP 350 OR MASH TESTING CRITERIA. ANY TERMINAL USED FOR THE GR-9 SHALL BE FROM THE VDOT APPROVED PRODUCTS LIST. STANDARD MB-3 TERMINAL OPTIONS ARE INCLUDED WITH THE GR-9 TERMINALS ON THE APPROVED PRODUCTS LIST.
2. ALL TERMINALS SHALL BE INSTALLED ACCORDING TO THE MANUFACTURER'S INSTALLATION INSTRUCTIONS AND THE FOLLOWING VDOT REQUIREMENTS:
 - A. ALL STANDARD GR-9 TERMINALS (SIMILAR TO AS SHOWN ABOVE) SHALL BE INSTALLED WITH A 1 FT. OFFSET ACCOMPLISHED WITH A 50:1 FLARE TO PREVENT THE GUARDRAIL EXTRUDER FROM ENCROACHING ON THE SHOULDER FOR 3R WORK WHERE RIGHT OF WAY IS LIMITED, THE OFFSET CAN BE DECREASED AS DIRECTED BY THE ENGINEER.
 - B. DIRECTION OF THE REFLECTIVE TAPE ON THE EXTRUDER SHALL CONFORM TO MUTCD APPLICATION FOR DIAGONAL STRIPES ON OBJECT MARKERS AND BRIDGE END PANELS. COLOR OF TAPE SHALL BE AMBER (YELLOW).
 - C. DO NOT CHANGE THE LAPPING OF TERMINAL FOR ANY INSTALLATIONS. INSTALL AS SHOWN ABOVE REGARDLESS OF ADJACENT TRAFFIC DIRECTION.
 - D. HEIGHT MEASURED AT TOP OF W-BEAM IS $27\frac{3}{4}$ " MIN. - $28\frac{3}{4}$ " MAX.
3. IF THE CALCULATED LENGTH OF NEED CANNOT BE MET FOR THE SITES OF RETROFIT, MAINTENANCE, OR UPGRADE OF TERMINALS, PROVIDE AS MUCH DISTANCE AS POSSIBLE TO THE HAZARD.
4. THIS DRAWING IS REPRESENTATIONAL ONLY. DETAILS, DIMENSIONS, QUANTITIES, AND OTHER INFORMATION NOT SHOWN WILL VARY FOR EACH MANUFACTURER. SEE INDIVIDUAL MANUFACTURER'S PLANS FOR THIS INFORMATION.



ROAD AND BRIDGE STANDARDS

SHEET 1 OF 2

REVISION DATE

501.16

10/14

A COPY OF THE ORIGINAL SEALED AND SIGNED DRAWING IS ON FILE IN THE CENTRAL OFFICE.
ALTERNATE BREAKAWAY CABLE TERMINAL
 NO FLARE

VIRGINIA DEPARTMENT OF TRANSPORTATION

SPECIFICATION REFERENCE

505

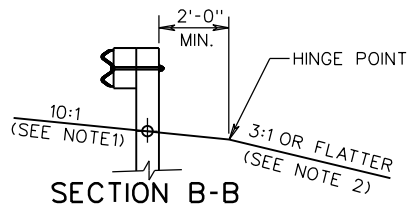
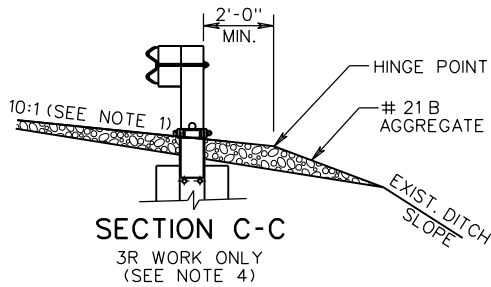
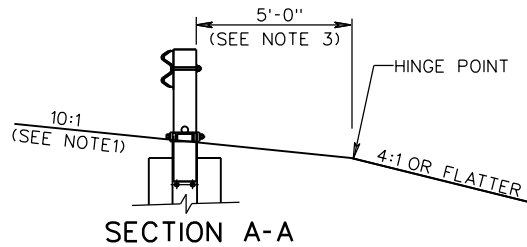

NOTES:

1. THE CROSS SLOPE OF THE GRADE APPROACHING THE GUARDRAIL TERMINAL, AND ADJACENT TO FOR ITS FULL LENGTH, MUST BE 10:1. IF THE EXISTING GRADE IS FLAT OR IS A POSITIVE SLOPE DUE TO THE SUPERELEVATION OF THE ROADWAY PAVEMENT, THE MINIMUM OFFSET FROM BEHIND THE POST TO THE HINGE POINT, AS SHOWN, IS REQUIRED.
2. THE AREA IMMEDIATELY BEHIND AND BEYOND THE TERMINAL SHOULD BE TRAVERSABLE AND FREE FROM FIXED OBJECTS. IF A CLEAR RUN OUT IS NOT ATTAINABLE THIS AREA SHOULD AT LEAST BE SIMILAR IN CHARACTER TO THE UPSTREAM UNSHIELDED ROADSIDE AREAS.
3. FOR NEW CONSTRUCTION AND RECONSTRUCTION THE 10:1 SLOPE GRADING MUST EXTEND A MINIMUM OF 5'-0" BEHIND THE END POST.
4. FOR 3R WORK, THE GRADING SHOULD BE AS CLOSE AS POSSIBLE TO THE NEW CONSTRUCTION WITH SLOPE EXTENDING A MINIMUM OF 2'-0" BEHIND THE BLOCKED OUT POST. FROM THE HINGE POINT, TIE THE GRADED SLOPE INTO THE EXISTING DITCH SLOPE TO COVER THE FOUNDATION TUBES AND SOIL PLATES WITHOUT EXTENDING THIS SLOPE BEYOND THE DITCH BOTTOM. USE #21B AGGREGATE, OR OTHER SUITABLE MATERIAL AS APPROVED BY THE ENGINEER, AT ROADWAY SHOULDERS.
5. THE TAPER FOR NEW CONSTRUCTION WILL BE 15:1. FOR 3R WORK THE MINIMUM ALLOWABLE TAPER IS 10:1.
6. FOR PROPRIETARY GUARDRAIL TERMINALS THE MANUFACTURER'S SITE PREPARATION REQUIREMENTS TAKE PRECEDENCE OVER THIS STANDARD.

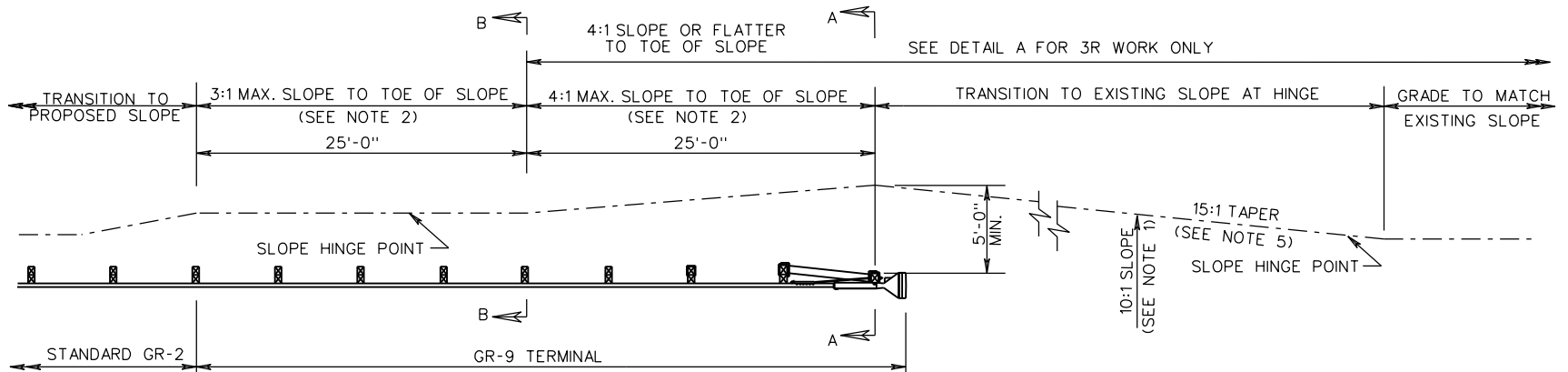
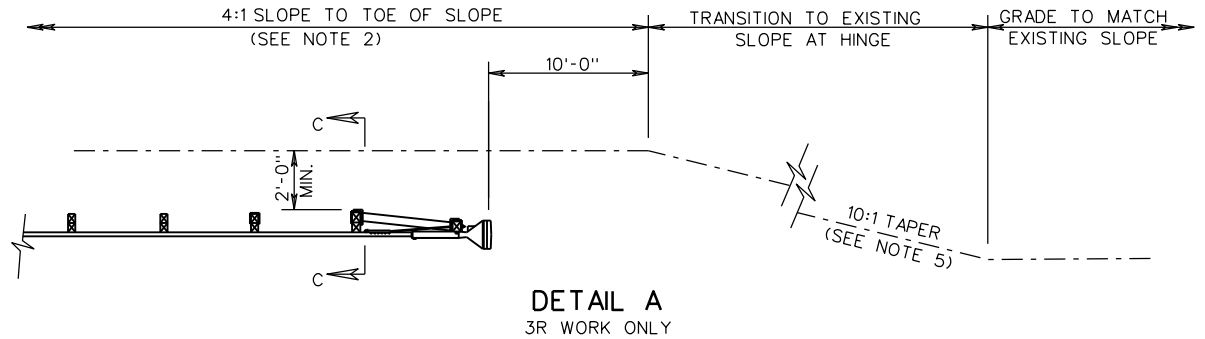

SITE PREPARATION REQUIREMENTS FOR GR-9

SPECIFICATION REFERENCE

A COPY OF THE ORIGINAL SEALED AND SIGNED DRAWING IS ON FILE IN THE CENTRAL OFFICE.
GUARDRAIL TERMINAL INSTALLATION SITE PREPARATION REQUIREMENTS FOR GR-9

VIRGINIA DEPARTMENT OF TRANSPORTATION

VDOT

ROAD AND BRIDGE STANDARDS

REVISION DATE

SHEET 2 OF 2

01/14

501.17

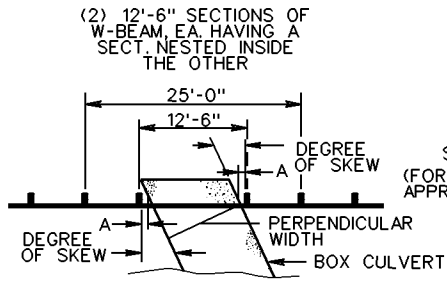

ONE POST OMITTED TOP VIEW

FOR DETAILS OF GUARDRAIL POSTS AND BLOCKOUTS, SEE STANDARD GR-2, 2A.

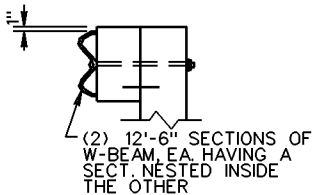
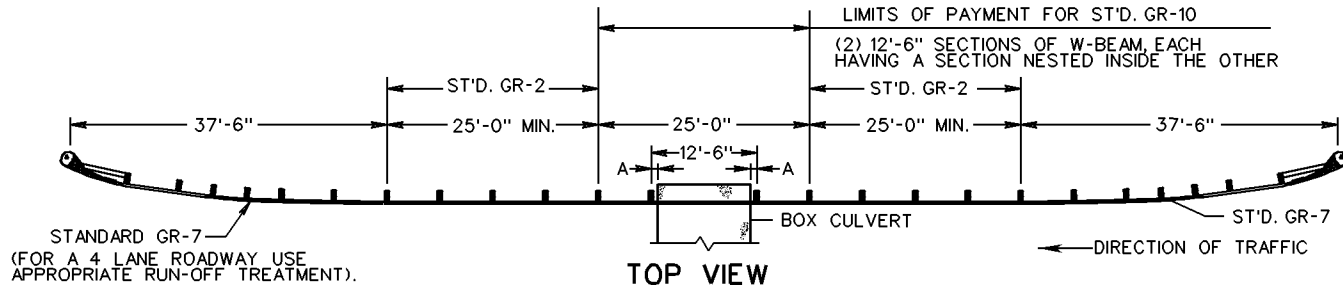

TABLE OF MAXIMUM ALLOWABLE STRUCTURE WIDTHS FOR THIS DESIGN

* "A" THE MINIMUM ALLOWABLE DISTANCE BETWEEN CLOSEST POINT OF POST TO STRUCTURE.

TYPE I- ONE POST OMITTED			TYPE II- TWO POST OMITTED		
SKEW	A*	MAX. PERPENDICULAR WIDTH (FEET)	SKEW	A*	MAX. PERPENDICULAR WIDTH (FEET)
0°	9"	10.5	0°	9"	16.75
5°	9"	10.4	5°	9"	16.6
10°	9"	10.2	10°	9"	16.4
15°	9"	10.0	15°	9"	16.0
20°	9"	9.6	20°	9"	15.5
25°	9"	9.2	25°	9"	14.9
30°	9"	8.8	30°	9"	14.2
35°	9"	8.2	35°	9"	13.2
40°	9"	7.6	40°	9"	12.4
45°	9"	7.0	45°	9"	11.4



TOP VIEW

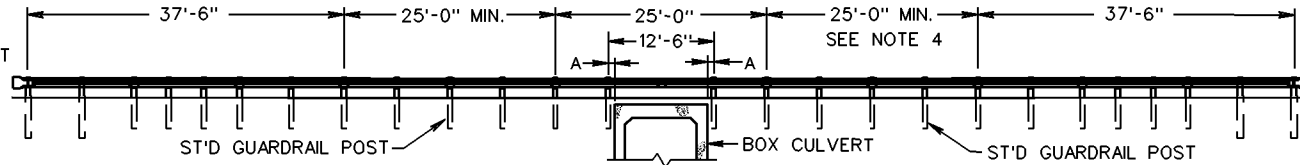

ELEVATION

TYPE I-ONE POST OMITTED

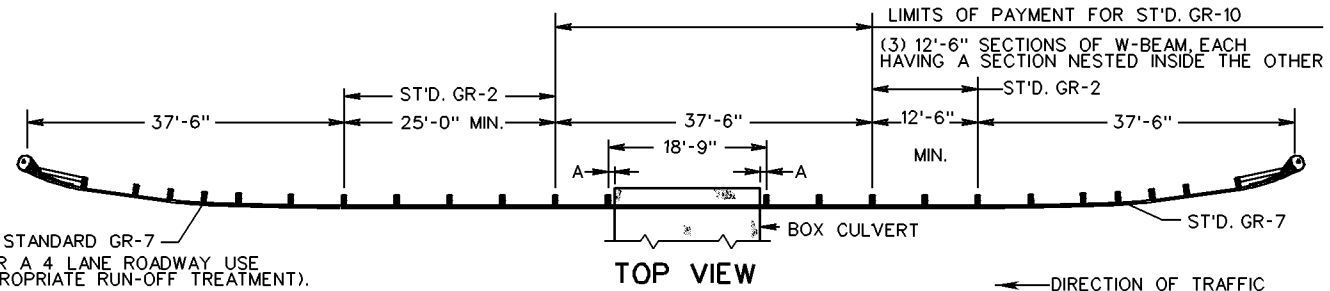

TOP VIEW

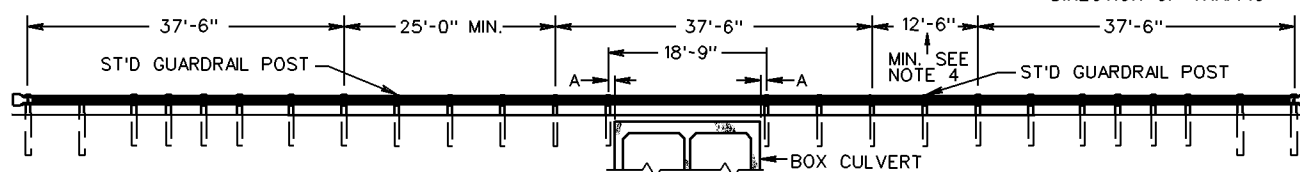

ELEVATION

TYPE II-TWO POSTS OMITTED

NOTES:

1. THIS SHEET IS APPLICABLE WHEN GUARDRAIL IS REQUIRED AND THE DEPTH OF FILL ABOVE THE TOP SLAB OF THE BOX CULVERT IS LESS THAN 4'-0".
2. GUARDRAIL INSTALLATION SHALL BE IN ACCORDANCE WITH SECTION 505 OF THE SPECIFICATIONS. MATERIAL REQUIREMENT FOR COMPONENTS SHALL BE IN ACCORDANCE WITH SECTION 221 OF THE SPECIFICATIONS.
3. GUARDRAIL POST SPACING SHALL BE IN ACCORDANCE WITH STANDARD GR-2.
4. THIS DISTANCE SHALL BE IN ACCORDANCE WITH VDOT POLICY ON DETERMINING THE LENGTH OF NEED FOR GUARDRAIL WITH A MINIMUM DISTANCE AS SHOWN.
5. ALL SPLICES IN NESTED W-BEAM SECTIONS MUST COINCIDE AT A COMMON POINT AND BE BOLTED TOGETHER USING ONE SET OF BOLTS AT EACH SPLICE.



ROAD AND BRIDGE STANDARDS

GUARDRAIL AT LOW-FILL CULVERTS

SPECIFICATION REFERENCE

SHEET 1 OF 2

REVISION DATE

VIRGINIA DEPARTMENT OF TRANSPORTATION

501.18

08/10

221
505

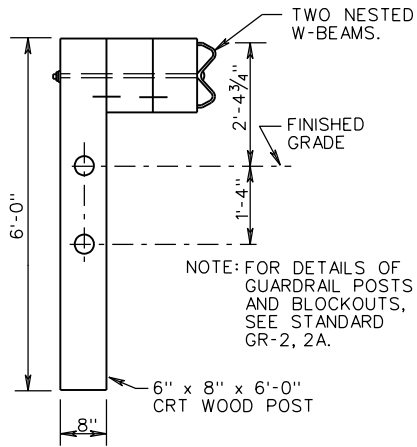

CRT POST WITH DOUBLE BLOCKOUTS

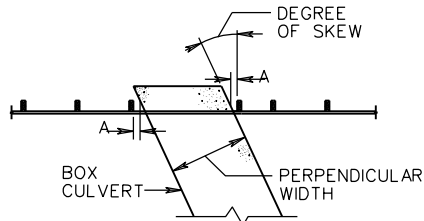

THREE POSTS OMITTED TOP VIEW

TYPE III-THREE POSTS OMITTED		
SKEW	A*	MAX. PERPENDICULAR WIDTH (FEET)
0°	9"	23.00
5°	9"	22.90
10°	9"	22.60
15°	9"	22.10
20°	9"	21.40
25°	9"	20.60
30°	9"	19.60
35°	9"	18.40
40°	9"	17.10
45°	9"	15.60

* "A" THE MINIMUM ALLOWABLE DISTANCE BETWEEN CLOSEST POINT OF POST TO STRUCTURE.

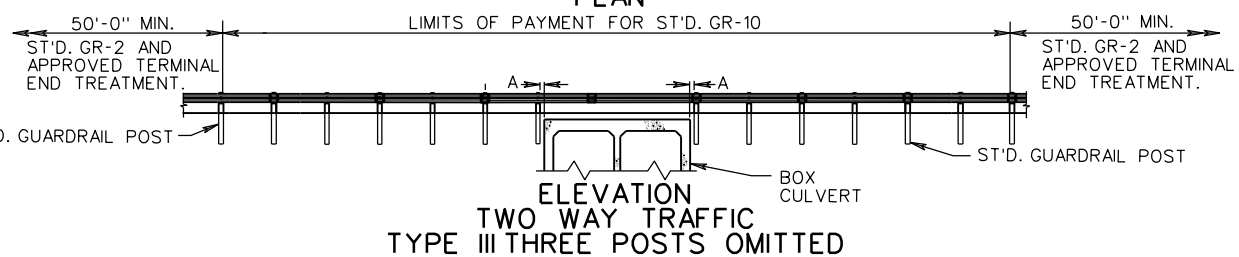
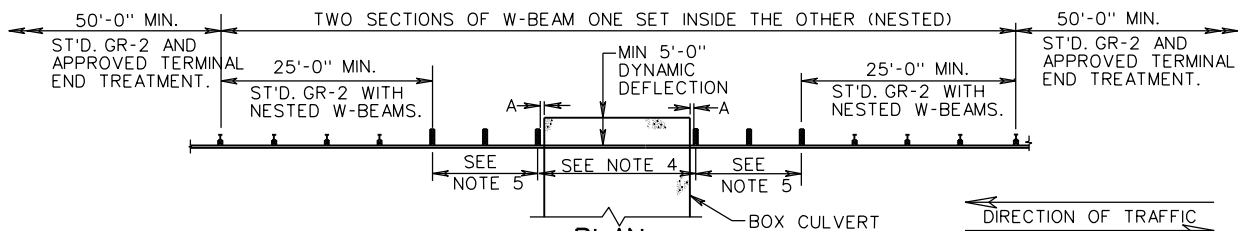
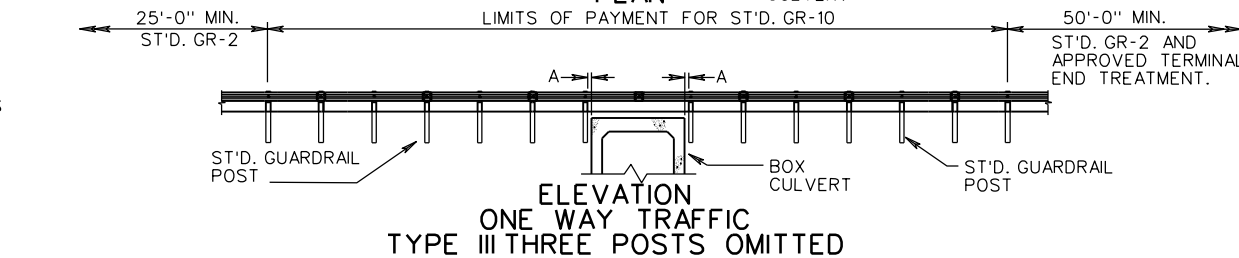
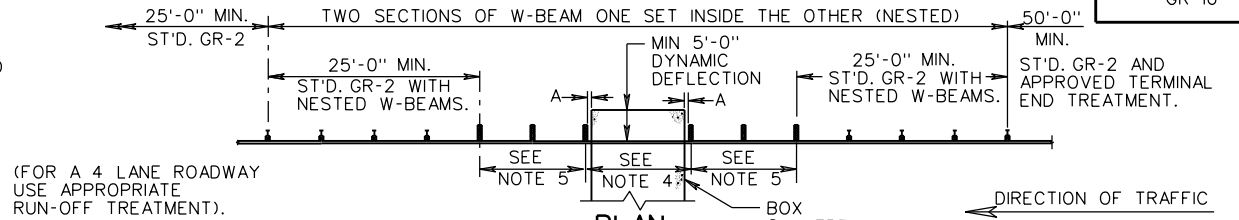

NOTES:

1. THIS SHEET IS APPLICABLE WHEN GUARDRAIL IS REQUIRED AND THE DEPTH OF FILL ABOVE THE TOP SLAB OF THE BOX CULVERT IS LESS THAN 4'-0".
2. GUARDRAIL INSTALLATION SHALL BE IN ACCORDANCE WITH SECTION 505 OF THE SPECIFICATIONS. MATERIAL REQUIREMENT FOR COMPONENTS SHALL BE IN ACCORDANCE WITH SECTION 221 OF THE SPECIFICATIONS.
3. GUARDRAIL POST SPACING SHALL BE IN ACCORDANCE WITH STANDARD GR-2.
4. TWO NESTED W-BEAM GUARDRAILS, SEE TABLE FOR ALLOWABLE WIDTHS (25'-0" MAXIMUM).
5. TWO NESTED W-BEAM GUARDRAILS, CRT WOODPOST, 6'-3" SPACING, WITH TWO 6"x8"x14" WOOD OR RECYCLED MATERIAL BLOCKOUTS.
6. ALL SPLICES IN NESTED W-BEAM SECTIONS MUST COINCIDE AT A COMMON POINT AND BE BOLTED TOGETHER USING ONE SET OF BOLTS AT EACH SPLICE.

SPECIFICATION REFERENCE

221
505

GUARDRAIL AT LOW-FILL CULVERTS

VIRGINIA DEPARTMENT OF TRANSPORTATION

VDOT

ROAD AND BRIDGE STANDARDS

REVISION DATE

7/11

SHEET 2 OF 2

501.19

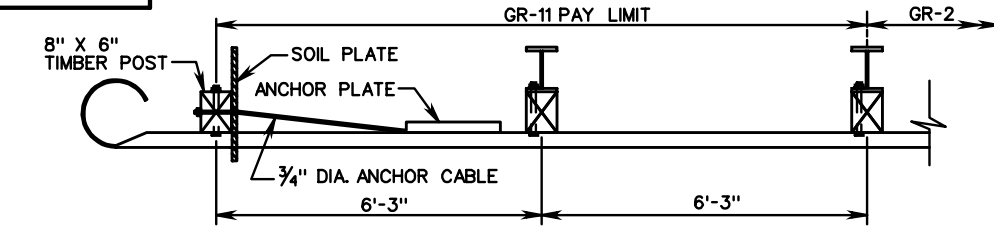

PLAN

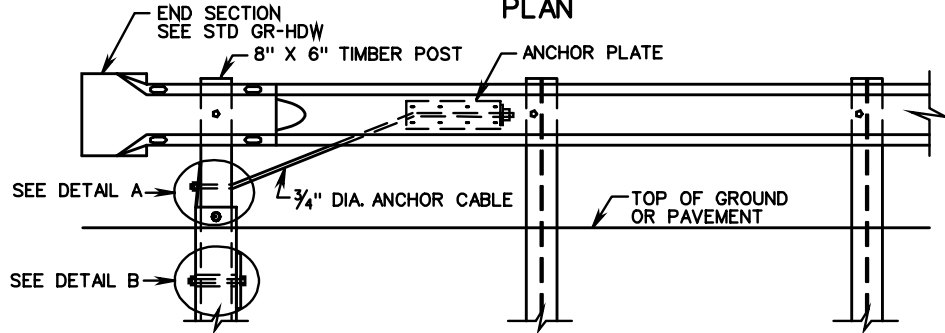

ELEVATION

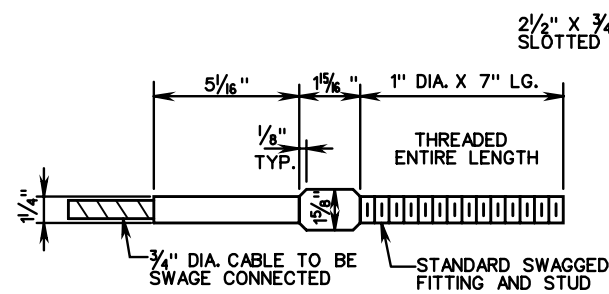

ANCHOR CABLE SWAGE CONNECTION TO THREADED STUD

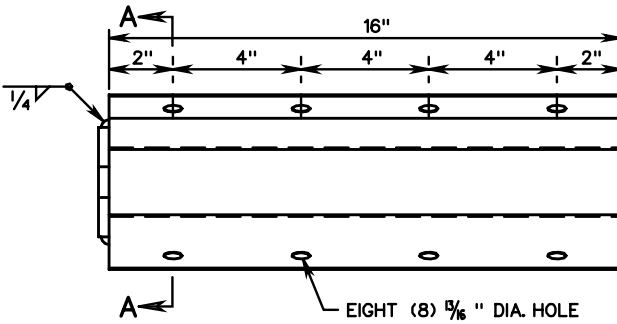

ANCHOR PLATE DETAILS

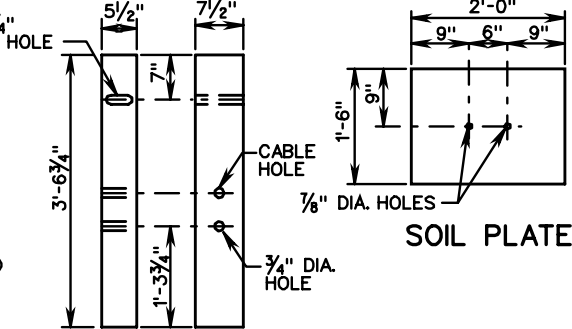

SHORT WOODEN POST

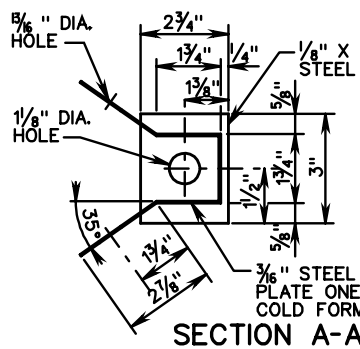

SECTION A-A

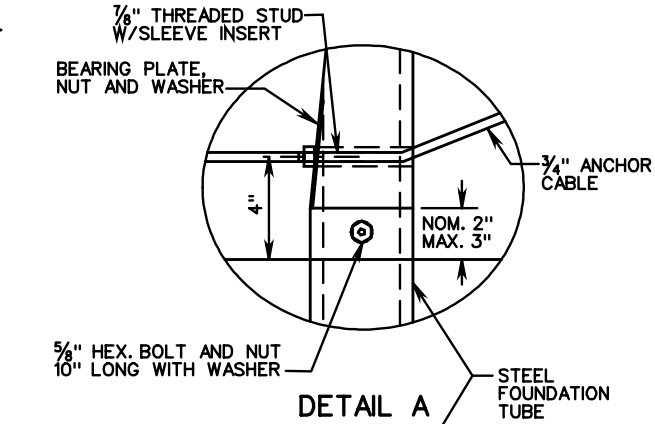

DETAIL A

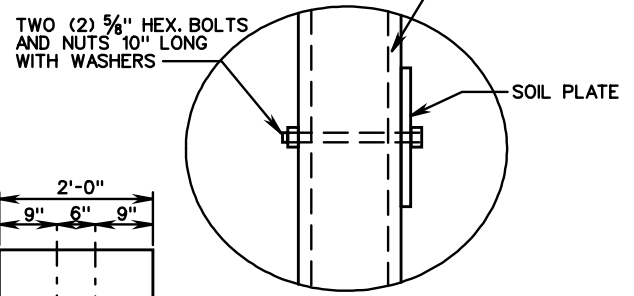

DETAIL B



SOIL PLATE

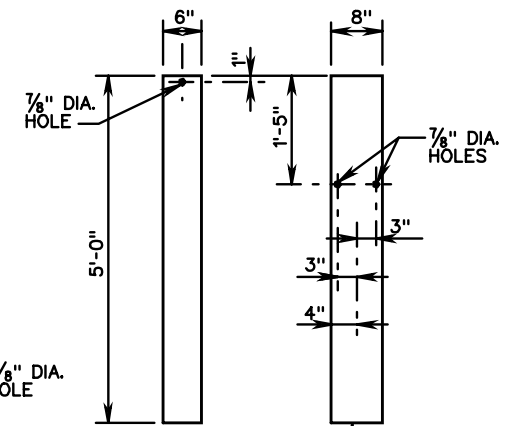

STEEL FOUNDATION TUBE

BEARING PLATE

NOTE: USE OF THIS TERMINAL TREATMENT IS RESTRICTED TO RUN-OFF CONDITIONS ON DIVIDED HIGHWAYS.

THIS PAGE INTENTIONALLY LEFT BLANK

SPECIFICATION
REFERENCE

--

--

VIRGINIA DEPARTMENT OF TRANSPORTATION



ROAD AND BRIDGE STANDARDS

REVISION DATE

SHEET 1 OF 1

501.21

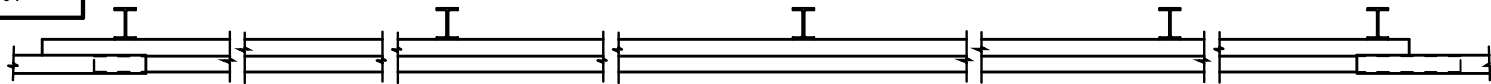

PLAN

NOTE: MAINTAIN 6'-3" POST SPACING WHEREVER POSSIBLE FOR USE WITH 25' STANDARD RAIL SECTION. SYMMETRY OF POST SPACING IS NOT NECESSARY.

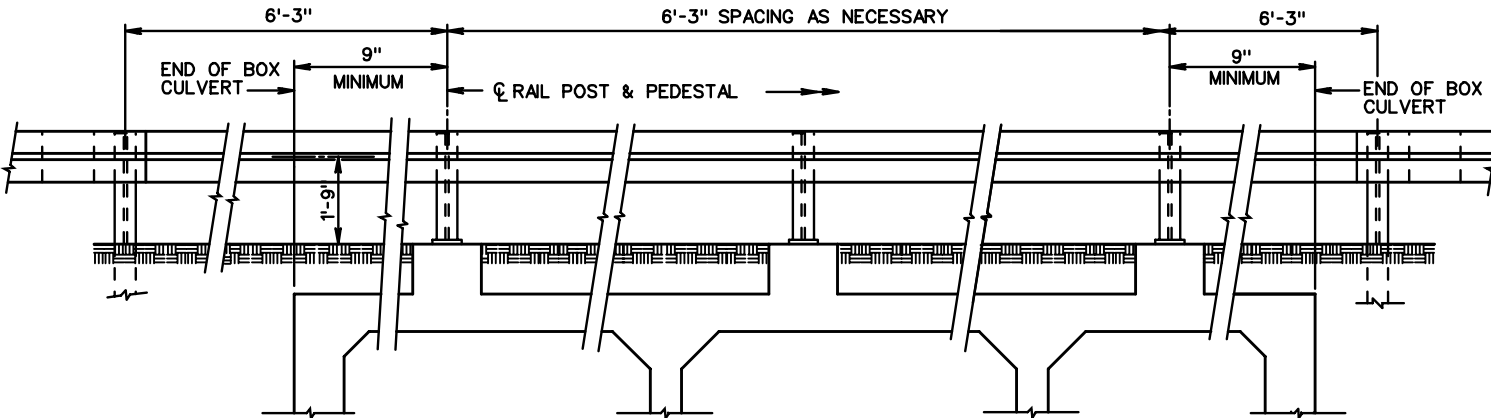

LONGITUDINAL SECTION

GENERAL NOTE:

ALL STRUCTURAL STEEL, INCLUDING BOLTS, NUTS, AND WASHERS SHALL BE GALVANIZED.

FOR DETAILS OF GUARDRAIL, SEE GR-2 OF THE ROAD AND BRIDGE STANDARDS.

THE GUARDRAIL INSTALLATION SHALL CONFORM WITH SECTION 505 OF THE CURRENT VIRGINIA DEPARTMENT OF TRANSPORTATION ROAD AND BRIDGE SPECIFICATIONS.

RAIL POSTS MAY BE VERTICAL OR PERPENDICULAR TO ADJACENT ROADWAY GRADE AND CROSS SLOPE. TOP OF PEDESTAL SHALL BE SLOPED AS NECESSARY FOR PERPENDICULAR INSTALLATION.

DETAILS ON THIS SHEET ARE TO BE USED FOR BOTH STRAIGHT AND SKEWED BOXES.

ANCHOR BOLTS SHALL BE 7/8" ØA307 (OR A36 THREADED RODS WITH TACK WELDED NUTS) WITH HEX NUTS AND WASHERS AS SHOWN. THREADED RODS MAY BE 0.781 MIN. DIAMETER WITH ROLLED THREADS. NUTS SHALL CONFORM TO A307 REQUIREMENTS AND SHALL BE TAPPED OR CHASED AFTER GALVANIZING. BOLTS AND NUTS SHALL HAVE CLASS 2A AND 2B FIT TOLERANCES. BOLTS SHALL BE EMBEDDED 8" INTO THE CONCRETE.

THIS RAIL HAS BEEN SUCCESSFULLY EVALUATED BY FULL SCALE IMPACT TESTS CONDUCTED IN ACCORDANCE WITH NCHRP REPORT 153. TEST DOCUMENTATION MAY BE FOUND IN RESEARCH REPORT 230-1, "TUBULAR W-BEAM BRIDGE RAIL", OF RESEARCH STUDY 2-5-78-230 "BRIDGE RAIL TO CONTAIN HEAVY TRUCKS AND BUSES", TEXAS TRANSPORTATION INSTITUTE, OCTOBER 1978.

TUBULAR GUARD RAIL SHALL BE FURNISHED AND INSTALLED IN 25 FT. SECTIONS. TUBULAR RAIL MEMBER SHALL BE EXTENDED AND CONNECTED TO AT LEAST THE FIRST SOIL EMBEDDED POST AT EACH END OF THE STRUCTURE. MORE SUCH POSTS SHALL BE USED TO UTILIZE 25 FT. STANDARD SECTIONS. APPROACH GUARDRAIL POSTS SHALL BE SPACED AT 6'-3" ADJACENT TO THE TUBULAR RAIL SINCE ITS FLEXIBILITY IS SIMILAR TO THE STANDARD METAL BEAM GUARDRAIL. DO NOT INSTALL ADDITIONAL POSTS AT 3'-1/2" CENTERS. FULLY ANCHORED GUARDRAIL MUST BE ATTACHED AT BOTH ENDS OF TUBULAR RAIL.

TESTS HAVE SHOWN THAT ALTHOUGH THIS RAIL DEFLECTS HORIZONTALLY TWO OR THREE FEET, ADEQUATE VEHICLE CONTAINMENT AND RE-DIRECTION IS ACHIEVED. THE RESULTING MORE GRADUAL DECELERATION THUS PRODUCES A SAFER CONDITION THAN AFFORDED BY OTHER BRIDGE RAILINGS.

THE CONTRACTOR SHALL DETERMINE THE NUMBER OF PEDESTALS REQUIRED FOR GUARDRAIL INSTALLATION ACROSS THE BOX, PEDESTAL HEIGHT AND DIMENSIONS OF THE BR SERIES REINFORCING BARS. THE QUANTITY OF CONCRETE (CLASS A4) AND REINFORCING STEEL USED IN THE PEDESTALS SHALL BE FIELD VERIFIED AND PAID FOR AT THE UNIT PRICE BID FOR THE CORRESPONDING BOX QUANTITIES. THE RAILING (TEXAS T-6) SHALL BE MEASURED IN 25 FT. SECTIONS AND PAID FOR AT THE CONTRACT UNIT PRICE PER LINEAR FOOT IN ACCORDANCE WITH SECTION 410.04 OF THE SPECIFICATIONS. BR SERIES BARS SHALL BE #5 IN SIZE.

FOR DETAILS OF BOX CULVERTS, SEE THE BOX CULVERT STANDARDS.

THIS SHEET IS APPLICABLE WHEN GUARDRAIL IS REQUIRED AND THE DEPTH OF FILL ABOVE THE TOP SLAB OF THE BOX CULVERT IS LESS THAN 3'-7".

DETAILS SHOWN ARE FOR INSTALLATION ON NEW BOX CULVERTS. INSTALLATION OF PEDESTALS ON EXISTING BOX CULVERTS SHALL BE IN ACCORDANCE WITH SEC. 412.03 OF THE SPECIFICATIONS EXCEPT THAT DOWELS SHALL BE PLACED BETWEEN 3 AND 6 INCHES FROM THE EDGE OF THE PEDESTAL.

PRECAST BOXES SHALL BE TREATED AS AN EXISTING BOX FOR PEDESTAL INSTALLATION.

THIS UNIT IS ONLY TO BE USED WHEN DESIGN SPEED IS 45 MPH OR LESS. TESTED - NCHRP 350 TEST LEVEL 2



ROAD AND BRIDGE STANDARDS

STANDARD BOX CULVERT GUARDRAIL

SPECIFICATION REFERENCE

SHEET 1 OF 3

REVISION DATE

(TEXAS T-6)

STRUCTURE AND BRIDGE DIVISION

501.22

VIRGINIA DEPARTMENT OF TRANSPORTATION

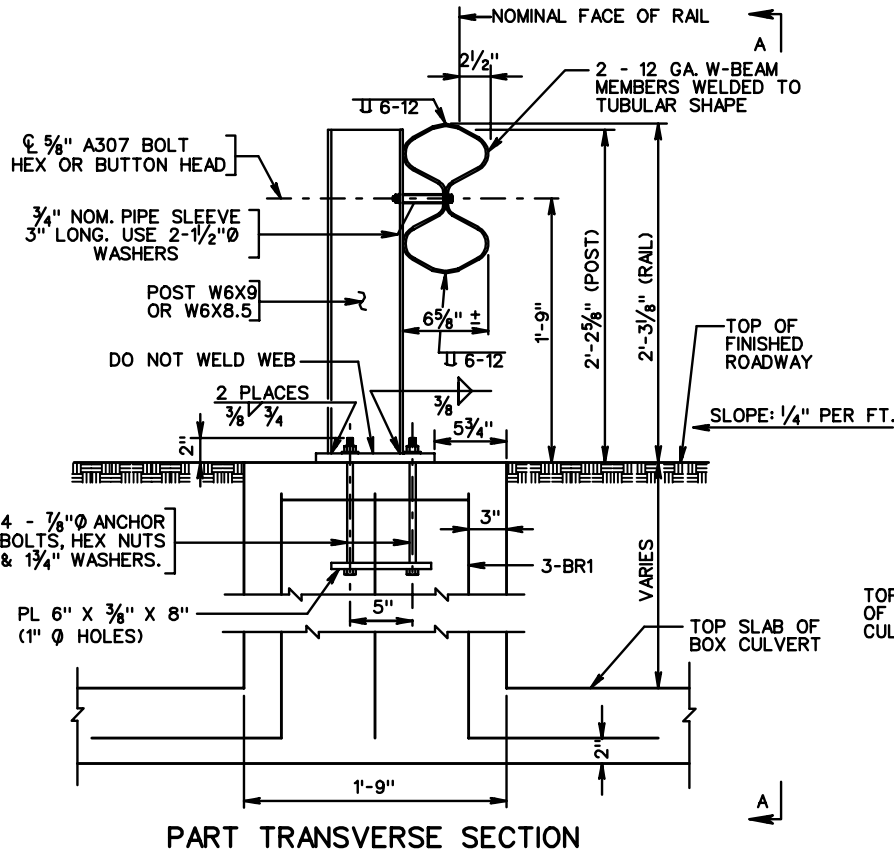

PART TRANSVERSE SECTION

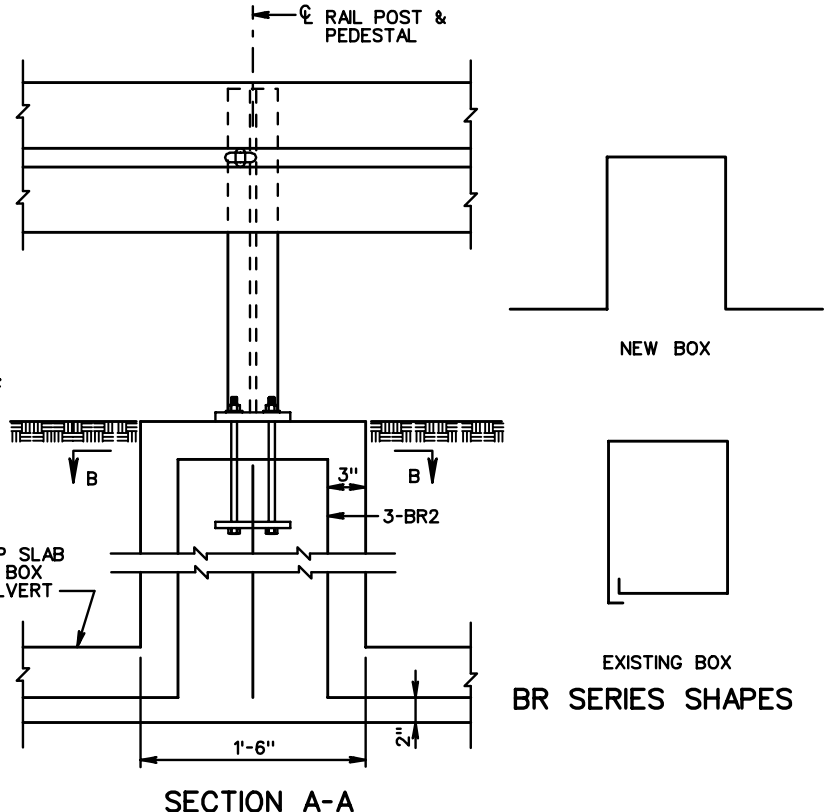

SECTION A-A

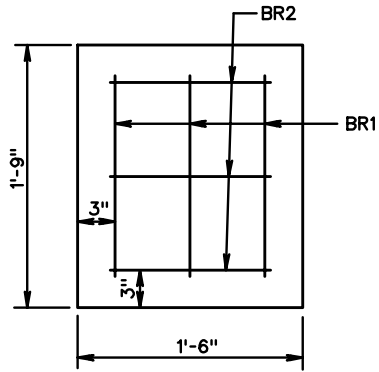

SECTION B-B
(ANCHOR BOLTS NOT SHOWN)

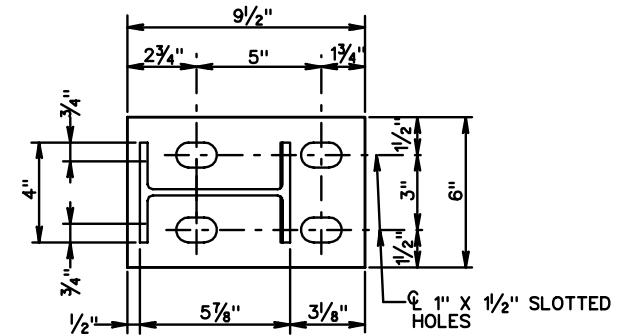
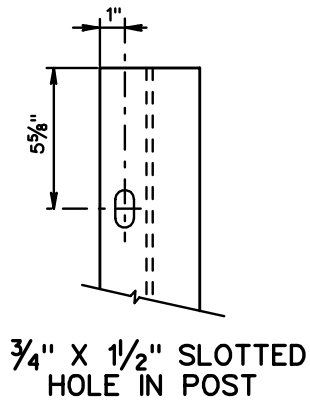

5/8" BASE PLATE
(1" X 1/2" SLOTTED HOLES)

SPECIFICATION REFERENCE

STRUCTURE AND BRIDGE DIVISION

STANDARD BOX CULVERT GUARDRAIL (TEXAS T-6)

VIRGINIA DEPARTMENT OF TRANSPORTATION

VDOT

ROAD AND BRIDGE STANDARDS

REVISION DATE

SHEET 2 OF 3

501.23

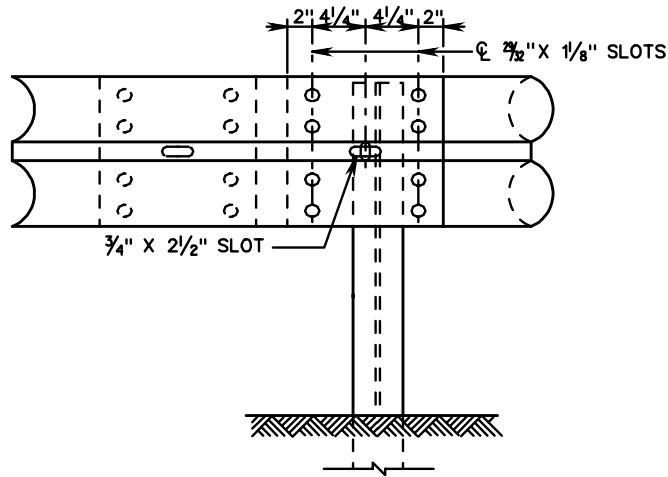
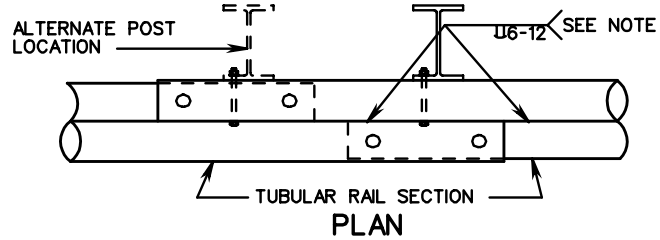
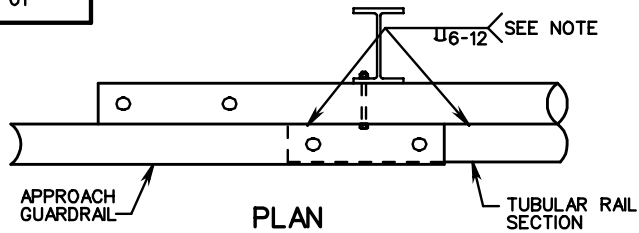

GUARDRAIL-TUBULAR RAIL SPLICE

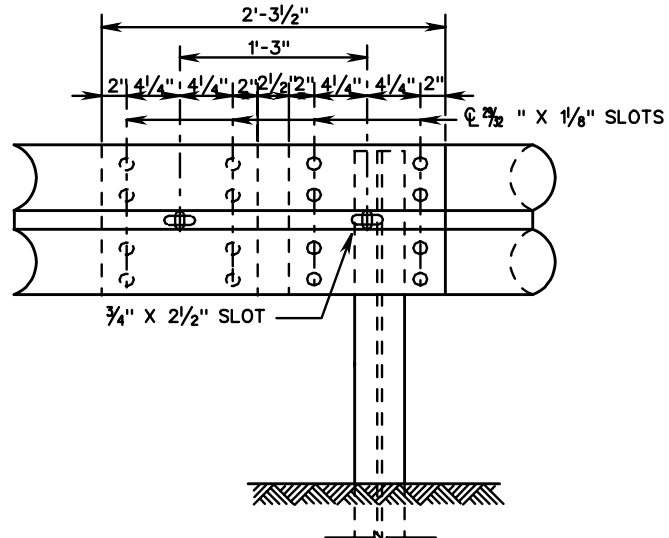

TUBULAR RAIL SPLICE

NOTES:

TUBULAR W-BEAM RAIL MEMBER IS TO BE FABRICATED FROM STANDARD 25' NOMINAL W-BEAM SECTIONS. TOP AND BOTTOM SEAMS SHALL BE BUTT WELDED 6" AT 12" SPACING. CONTINUOUS SEAM WELDING IS ALSO ACCEPTABLE. WELDS SHALL BE CHIPPED AND CLEANED AND THE COMPLETE 25 FT. TUBULAR MEMBER SHALL BE GALVANIZED AFTER FABRICATION. FOR TUBULAR RAIL SPLICE ADDITIONAL POST MOUNTING SLOTS ARE TO BE MADE IN EACH MEMBER 1'-3" FROM THE STANDARD SLOTS AT 6'-3" CENTERS.

8-5/8" SPLICE NUTS SHALL BE TACK WELDED TO A BENT SHEET METAL POSITIONER AS SHOWN. OTHER SUITABLE POSITIONING METHODS OR DEVICES MAY BE SUBSTITUTED. THE COMPLETED SPLICE SHALL HAVE 8 BOLTS (16 BOLTS IF A TUBULAR RAIL SPLICE). EACH BOLT WILL INCLUDE A 1 3/4" X 3" X 3/16" PLATE WASHER OR A 2 INCH DIAMETER WASHER.

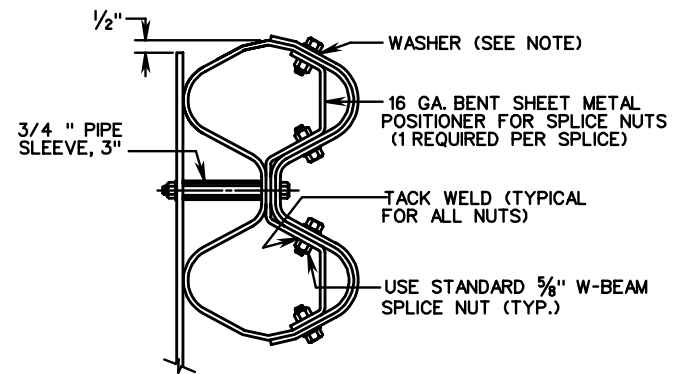

SPLICE DETAIL



ROAD AND BRIDGE STANDARDS

STANDARD BOX CULVERT GUARDRAIL
(TEXAS T-6)

SPECIFICATION
REFERENCE

SHEET 3 OF 3

REVISION DATE

STRUCTURE
AND
BRIDGE DIVISION

501.24

VIRGINIA DEPARTMENT OF TRANSPORTATION

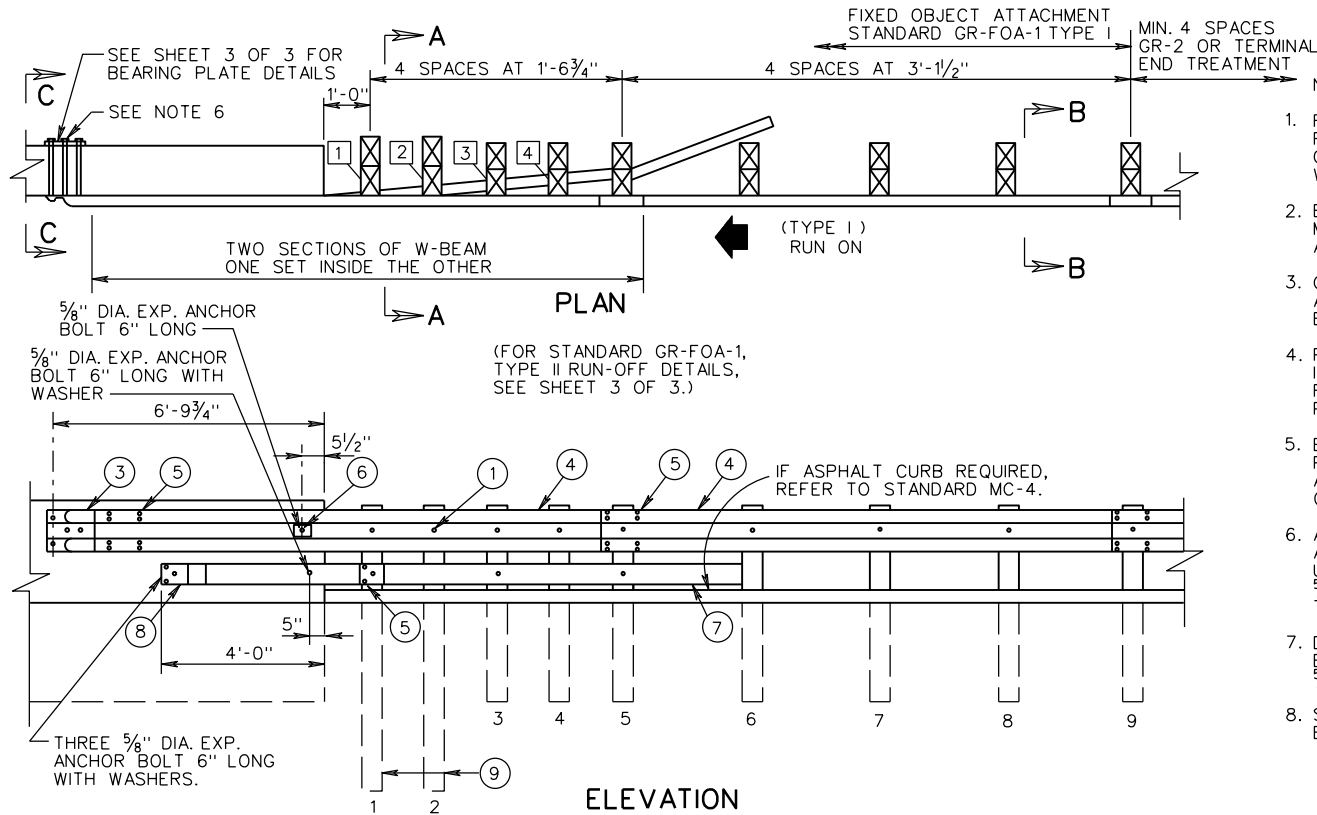

- NOTES:
1. FIXED OBJECTS MAY CONSIST OF BRIDGE RAILS, ABUTMENTS, PIERS, RETAINING WALLS, OR OTHER FLAT SURFACED STRUCTURES WITH VERTICAL FACE.
 2. BRIDGE RAIL ENDS AND BRIDGE PARAPETS MUST BE OF ADEQUATE STRENGTH TO ACCEPT FULL IMPACT LOADING.
 3. GUARDRAIL COMPONENTS SHALL BE IN ACCORDANCE WITH VDOT ROAD AND BRIDGE STANDARDS.
 4. POSTS 1, 2, 3, 4, AND 5 REQUIRE AN ADDITIONAL HOLE TO ATTACH BLOCKS AND/OR RUBRAIL. RUBRAIL IS NOT BOLTED TO POSTS 2 AND 4.
 5. BOTTOM WOOD BLOCKS LOCATED ON POSTS 1 THROUGH 4 ARE CENTER DRILLED AND SECURED WITH 5/8" GUARDRAIL BOLTS (LENGTH AS REQUIRED).
 6. APPROPRIATE LENGTH 7/8" DIAMETER ASTM A449 HEX BOLTS WITH WASHERS MUST BE USED WITH THRU DRILLED HOLES AND A 5/8" BEARING PLATE ON THE BACK SIDE OF THE BRIDGE PARAPET OR TERMINAL WALL.
 7. DRIVE NAIL WITHIN 2" OF THE TOP OR BOTTOM OF THE BLOCKOUT AFTER 5/8" X 18 BOLT IS INSTALLED.
 8. SEE SHEET 3 OF 3 FOR RUBRAIL BLOCKOUT DETAILS.

NEW BRIDGES - ATTACHMENTS
 ONE WAY TRAFFIC - RUN-ON, 2-GR-FOA-1, TYPE I
 - RUN-OFF, 2-GR-FOA-1, TYPE II
 TWO WAY TRAFFIC - RUN-ON, 4-GR-FOA-1, TYPE I
 EXISTING BRIDGE ATTACHMENTS AS SHOWN ON PLANS.

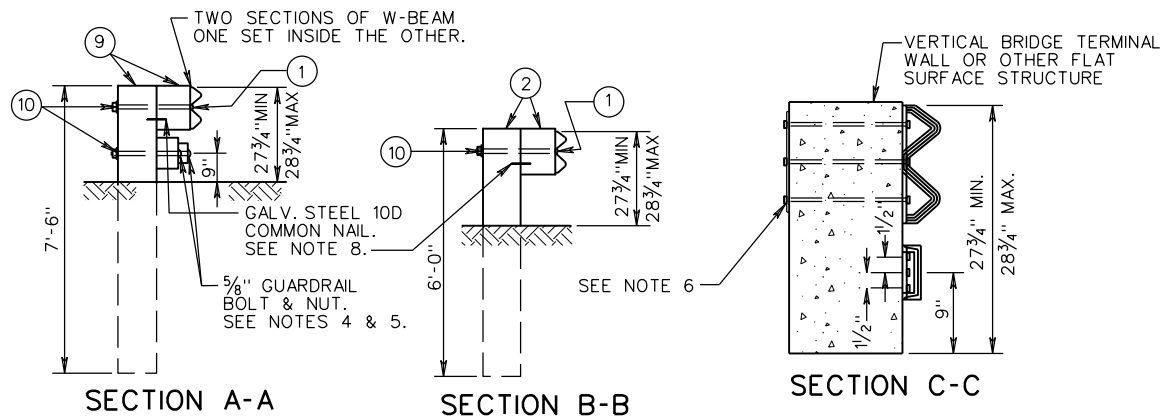

ITEM	MATERIAL/SPECIFICATIONS/NOTES
①	5/8" X 18" LONG GUARDRAIL BOLT AND RECESSED NUT
②	STANDARD 6" X 8" WOOD POST AND BLOCK
③	STANDARD W-BEAM TERMINAL CONNECTOR
④	STANDARD W-BEAM RAIL
⑤	5/8" X 2" LONG GUARDRAIL BOLT & RECESSED NUT (SEE ST'D. GR-HDW)
⑥	RECTANGULAR PLATE WASHER (SEE ST'D. GR-HDW)
⑦	BENT PLATE RUBRAIL (SEE SHEET 3 OF 3)
⑧	C6 X 8.2 RUBRAIL (SEE SHEET 3 OF 3)
⑨	8" X 8" X 7'-6" LONG WOOD POST & 8" X 8" X 14" LONG TREATED PINE BLOCK OR RECYCLED MATERIAL
⑩	WASHER FOR 5/8" BOLT

SPECIFICATION REFERENCE
 505

A COPY OF THE ORIGINAL SEALED AND SIGNED DRAWING IS ON FILE IN THE CENTRAL OFFICE.

W-BEAM GUARDRAIL - FIXED OBJECT ATTACHMENT

FOR USE BETWEEN VERTICAL FIXED OBJECTS AND GUARDRAIL (WOOD POSTS)

VIRGINIA DEPARTMENT OF TRANSPORTATION

VDOT
 ROAD AND BRIDGE STANDARDS

REVISION DATE 01/14

SHEET 1 OF 3
 501.25

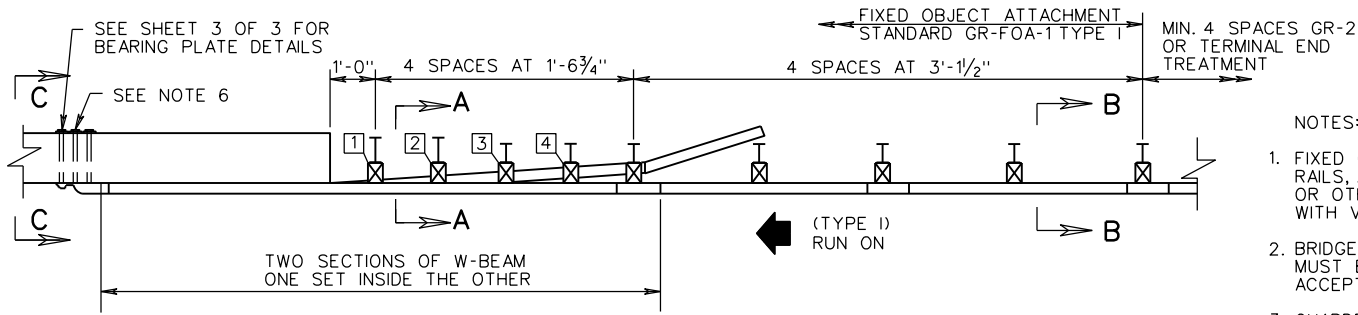

PLAN

(FOR STANDARD GR-FOA-1, TYPE II RUN-OFF DETAILS, SEE SHEET 3 OF 3)

IF ASPHALT CURB REQUIRED, REFER TO STANDARD MC-4

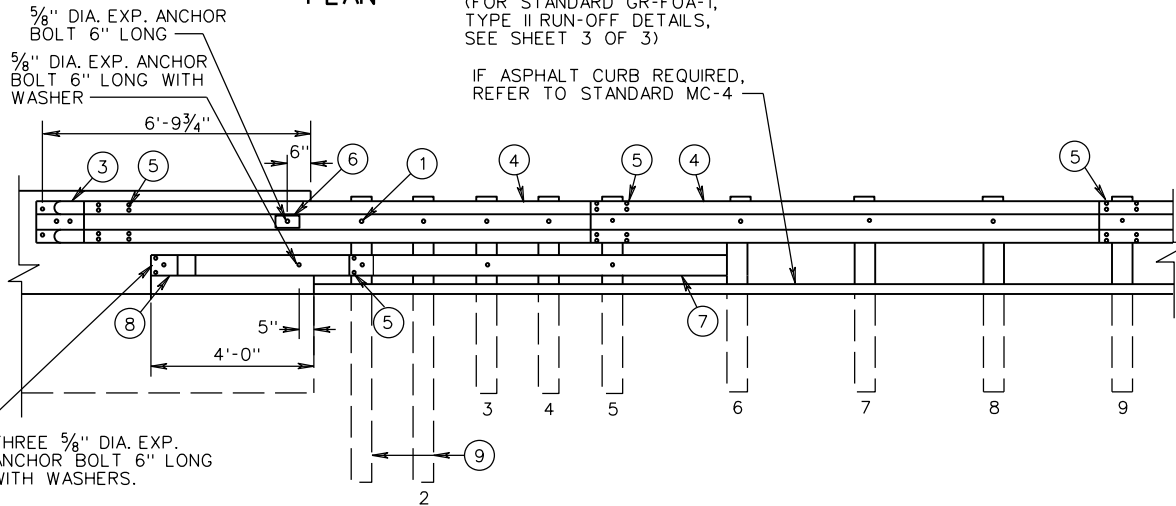

ELEVATION

NEW BRIDGES - ATTACHMENTS
 ONE WAY TRAFFIC - RUN-ON, 2-GR-FOA-1, TYPE I
 - RUN-OFF, 2-GR-FOA-1, TYPE II
 TWO WAY TRAFFIC - RUN-ON, 4-GR-FOA-1, TYPE I

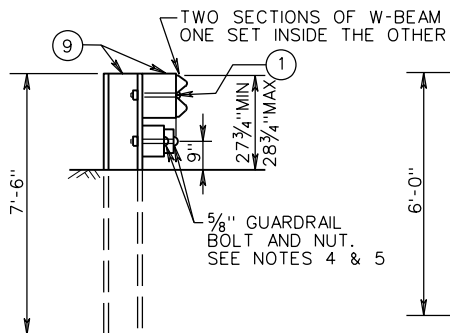

SECTION A-A

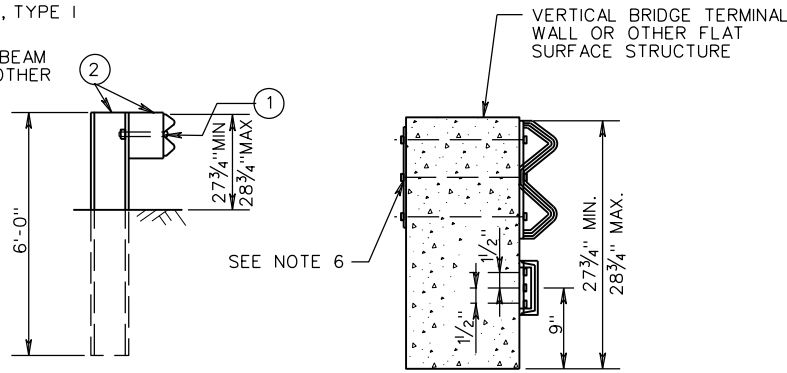

SECTION B-B

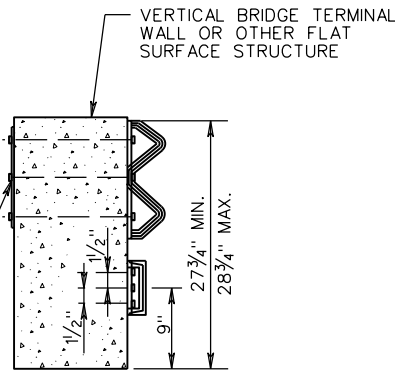

SECTION C-C

NOTES:

1. FIXED OBJECTS MAY CONSIST OF BRIDGE RAILS, ABUTMENTS, PIERS, RETAINING WALLS, OR OTHER FLAT SURFACED STRUCTURES WITH VERTICAL FACE.
2. BRIDGE RAIL ENDS AND BRIDGE PARAPETS MUST BE OF ADEQUATE STRENGTH TO ACCEPT FULL IMPACT LOADING.
3. GUARDRAIL COMPONENTS SHALL BE IN ACCORDANCE WITH VDOT ROAD AND BRIDGE STANDARDS.
4. POSTS 1, 2, 3, 4, AND 5 REQUIRE AN ADDITIONAL HOLE TO ATTACH BLOCKS AND/OR RUBRAIL. RUBRAIL IS NOT BOLTED TO POSTS 2 AND 4.
5. BOTTOM WOOD BLOCKS LOCATED ON POSTS 1 THROUGH 4 ARE CENTER DRILLED AND SECURED WITH 5/8" GUARDRAIL BOLTS (LENGTH AS REQUIRED).
6. APPROPRIATE LENGTH 7/8" DIAMETER ASTM A449 HEX BOLTS WITH WASHERS MUST BE USED WITH THRU DRILLED HOLES AND A 5/8" BEARING PLATE ON THE BACK SIDE OF THE BRIDGE PARAPET OR TERMINAL WALL.
7. SEE SHEET 3 OF 3 FOR RUBRAIL BLOCKOUT DETAILS.

ITEM	MATERIAL/SPECIFICATIONS/NOTES
①	5/8" X 10" LONG GUARDRAIL BOLT & RECESSED NUT
②	ST'D. W6X8.5 OR W6X9 STEEL POST ST'D. 6X8X14" LG. TREATED PINE BLOCK OR RECYCLED MATERIAL
③	STANDARD W-BEAM TERMINAL CONNECTOR
④	STANDARD W-BEAM RAIL
⑤	5/8" X 2" LONG GUARDRAIL BOLT & RECESSED NUT (SEE STANDARD GR-HDW)
⑥	RECTANGULAR PLATE WASHER (SEE ST'D. GR-HDW)
⑦	BENT PLATE RUBRAIL (SEE SHEET 3 OF 3)
⑧	C6 X 8.2 RUBRAIL (SEE SHEET 3 OF 3)
⑨	W8 X 13 X 7'-6" LONG STEEL POST WITH STANDARD 6" X 8" X 14" LONG TREATED PINE BLOCK OR RECYCLED MATERIAL



ROAD AND BRIDGE STANDARDS

A COPY OF THE ORIGINAL SEALED AND SIGNED DRAWING IS ON FILE IN THE CENTRAL OFFICE.
W-BEAM GUARDRAIL-FIXED OBJECT ATTACHMENT
 FOR USE BETWEEN VERTICAL FIXED OBJECTS AND GUARDRAIL (STEEL POSTS)

SPECIFICATION REFERENCE

SHEET 2 OF 3

REVISION DATE

505

501.26

01/14

VIRGINIA DEPARTMENT OF TRANSPORTATION

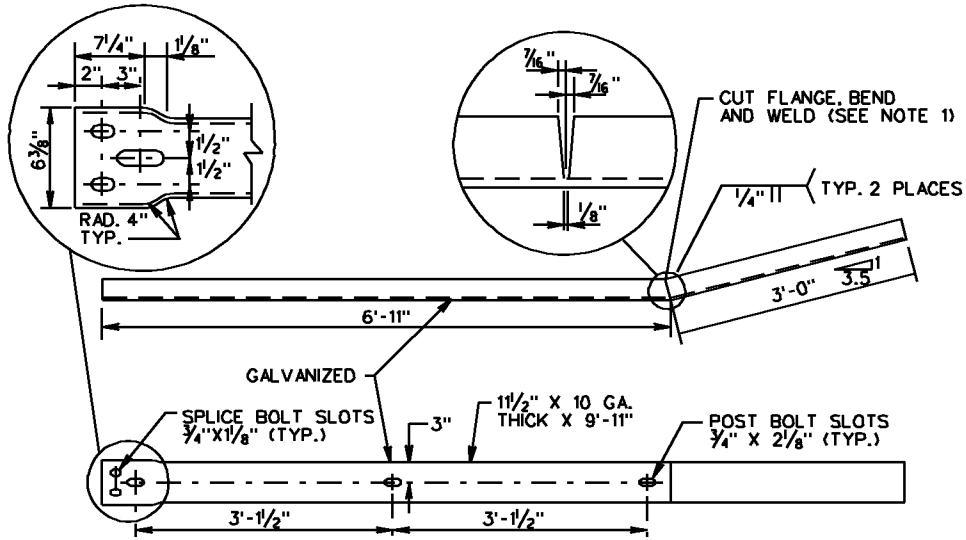

NOTE:
CAN BE FIELD CUT AND BENT USING HEAT.
IF SHOP CUT AND BENT, RIGHT HAND OR LEFT
HAND MUST BE SPECIFIED DEPENDING ON
WHICH SIDE OF THE ROADWAY THE TRANSITION
IS USED.

ITEM 7 DETAIL

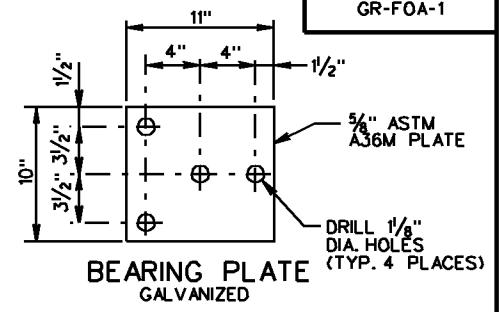

☆ CAN BE FIELD CUT AND BENT USING HEAT.

WOOD POSTS
RUBRAIL BLOCKOUTS
7" X 4" X THICKNESS

POST	THICKNESS
1	6 1/8"
2	4 3/8"
3	3 1/4"
4	1 3/4"

STEEL POSTS
RUBRAIL BLOCKOUTS
7" X 4" X THICKNESS

POST	THICKNESS
1	5 3/4"
2	4 1/4"
3	2 7/8"
4	1 3/8"

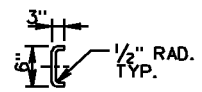

INDICATES EXTRA POST REQ'D FOR
RUN-OFF FIXED OBJECT ATTACHMENT
ST'D. GR-FOA-1 TYPE II

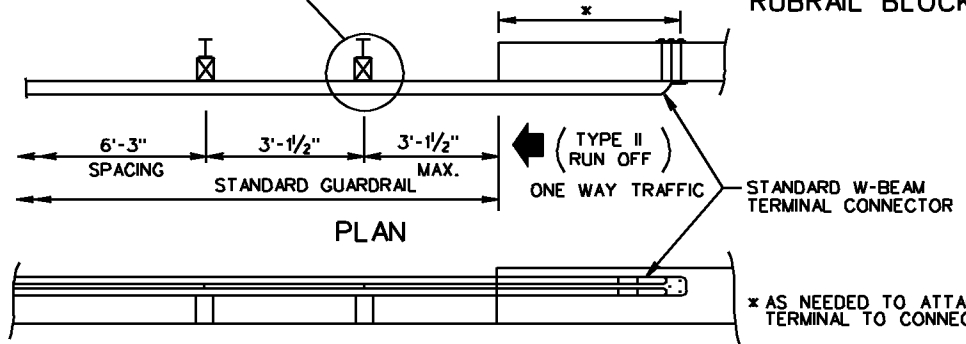

ELEVATION

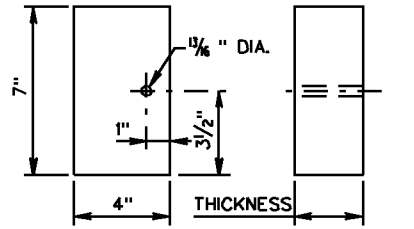

RUBRAIL BLOCKOUT DETAIL

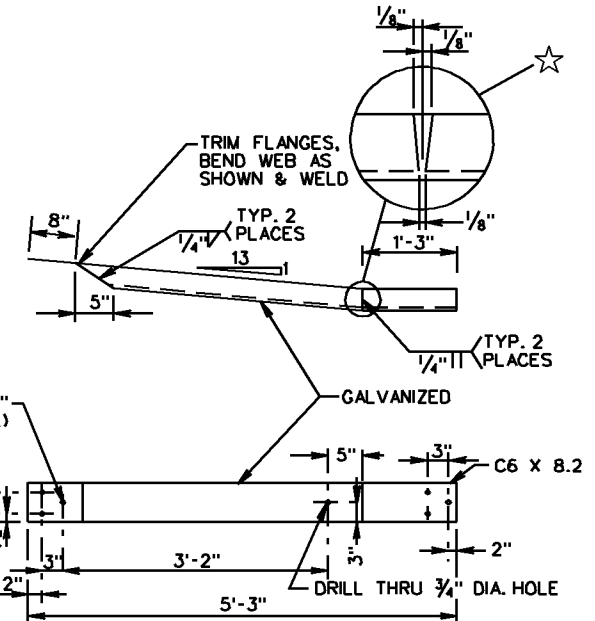

ITEM 8 DETAIL

SPECIFICATION REFERENCE	505	W-BEAM GUARDRAIL - FIXED OBJECT ATTACHMENT (RUBRAIL AND HARDWARE DETAILS) VIRGINIA DEPARTMENT OF TRANSPORTATION	VDOT ROAD AND BRIDGE STANDARDS	
			REVISION DATE 4/09	SHEET 3 OF 3 501.27

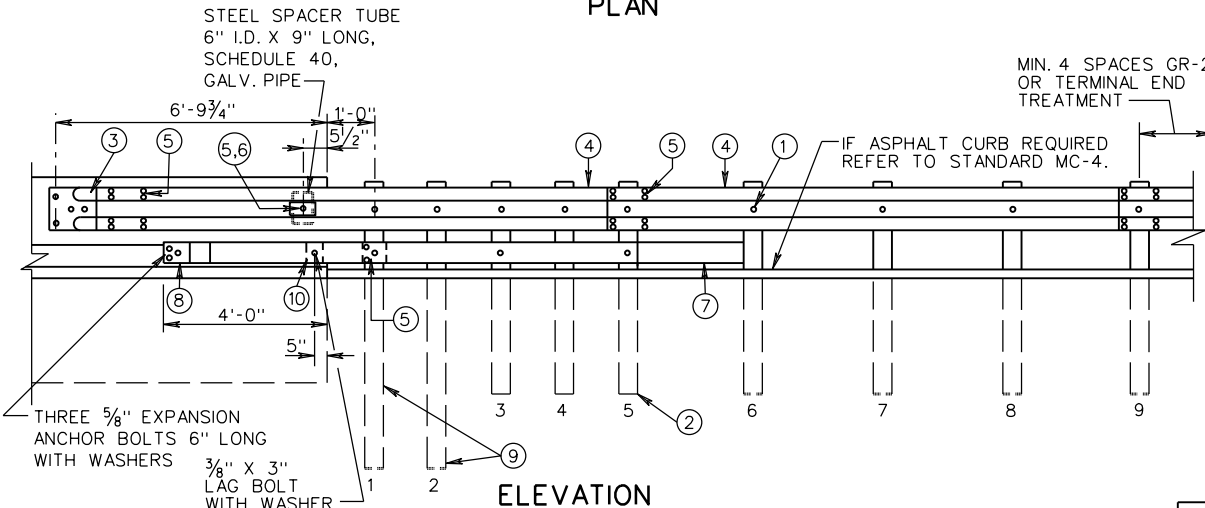
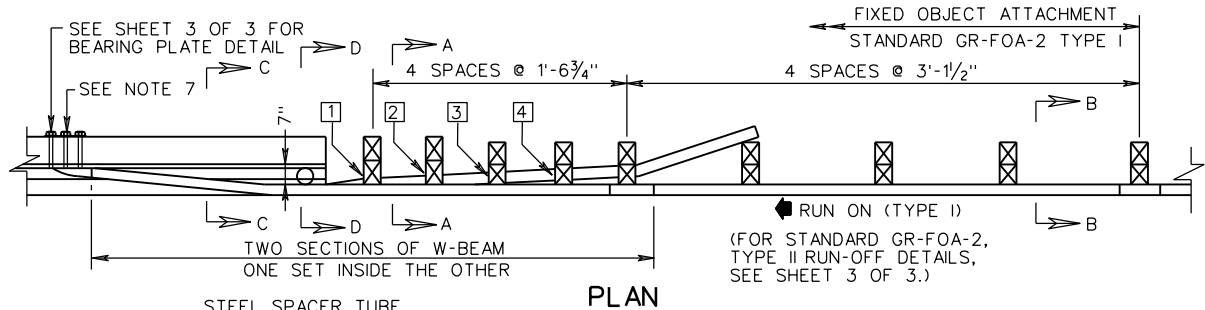

- NOTES:
1. FIXED OBJECTS MAY CONSIST OF SAFETY SHAPED BRIDGE PARAPETS OR CONCRETE BARRIERS.
 2. BRIDGE RAIL ENDS AND BRIDGE PARAPETS MUST BE OF ADEQUATE STRENGTH TO ACCEPT FULL IMPACT LOADING.
 3. GUARDRAIL COMPONENTS SHALL BE IN ACCORDANCE WITH VDOT ROAD AND BRIDGE STANDARDS.
 4. POSTS 1, 2, 3, 4, AND 5 REQUIRE AN ADDITIONAL HOLE TO ATTACH LOWER BLOCKS AND/OR RUBRAIL. RUBRAIL IS NOT BOLTED TO POSTS 2 AND 4.
 5. BOTTOM WOOD BLOCKS LOCATED ON POSTS 1 THROUGH 4 ARE CENTER DRILLED AND SECURED WITH 5/8" GUARDRAIL BOLTS. (LENGTH AS REQUIRED).
 6. RUBRAIL MUST BE TWISTED 35° BETWEEN SECTION C-C AND D-D. SHOP FABRICATION MAY BE REQUIRED. RIGHT HAND AND LEFT HAND TWISTS WILL BE NECESSARY.
 7. APPROPRIATE LENGTH 7/8" ASTM A449 HEX BOLTS WITH WASHERS MUST BE USED WITH THRU DRILLED HOLES AND A 5/8" BEARING PLATE ON THE BACK SIDE OF THE BRIDGE PARAPET OR CONCRETE BARRIER.
 8. DRIVE NAIL WITHIN 2" OF THE TOP OR BOTTOM OF BLOCKOUT AFTER 5/8" X 18 BOLT IS INSTALLED.
 9. SEE SHEET 3 OF 3 FOR RUBRAIL BLOCKOUT DETAILS.

NEW BRIDGE - ATTACHMENTS
 ONE-WAY TRAFFIC-RUN-ON, 2-GR-FOA-2, TYPE I
 -RUN-OFF, 2-GR-FOA-2, TYPE II
 TWO-WAY TRAFFIC-RUN-ON, 4-GR-FOA-2, TYPE I
 EXISTING BRIDGE ATTACHMENTS AS SHOWN ON PLANS.

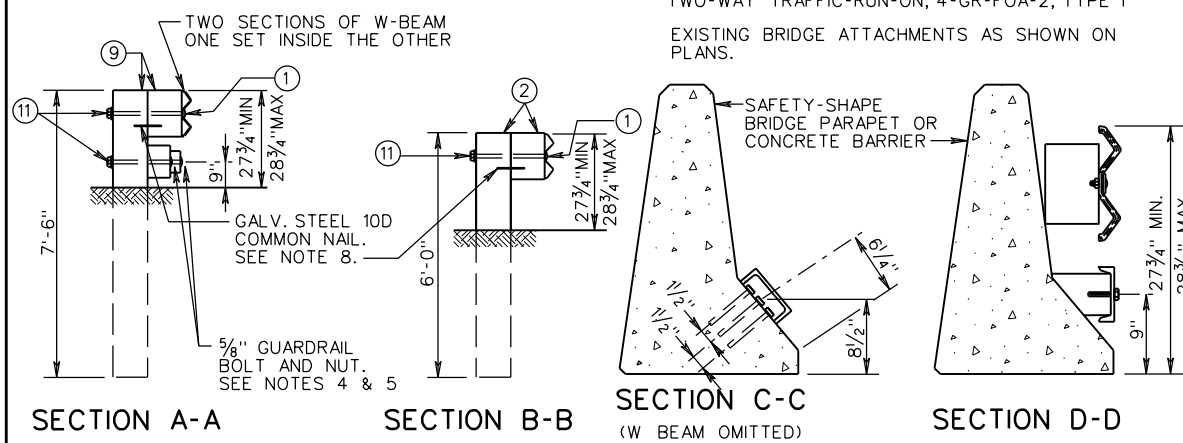

ITEM	MATERIAL/SPECIFICATIONS/NOTES
①	5/8" X 18" LG. GUARDRAIL BOLT AND RECESSED NUT.
②	STANDARD 6" X 8" WOOD POST AND BLOCK.
③	STANDARD W-BEAM TERMINAL CONNECTOR
④	STANDARD W-BEAM RAIL
⑤	5/8" X 2" LONG GUARDRAIL BOLT AND RECESSED NUT (SEE STANDARD GR-HDW)
⑥	RECTANGULAR PLATE WASHER (SEE STANDARD GR-HDW)
⑦	BENT PLATE RUBRAIL (SEE SHEET 3 OF 3)
⑧	C6 X 8.2 RUBRAIL (SEE SHEET 3 OF 3)
⑨	8" X 8" X 7'-6" LONG WOOD POST AND 8" X 8" X 14" LONG TREATED PINE BLOCK OR RECYCLED MATERIAL
⑩	WOOD BLOCKOUT FOR RUBRAIL (SEE SHEET 3 OF 3)
⑪	WASHER FOR 5/8" BOLT

<p>ROAD AND BRIDGE STANDARDS</p>		<p>A COPY OF THE ORIGINAL SEALED AND SIGNED DRAWING IS ON FILE IN THE CENTRAL OFFICE.</p> <h2 style="text-align: center;">W-BEAM GUARDRAIL - FIXED OBJECT ATTACHMENT</h2> <p style="text-align: center;">FOR USE BETWEEN SAFETY SHAPE AND GUARDRAIL (WOOD POSTS)</p> <p style="text-align: center;">VIRGINIA DEPARTMENT OF TRANSPORTATION</p>		<p>SPECIFICATION REFERENCE</p> <p>505</p>
<p>SHEET 1 OF 3</p> <p>501.28</p>	<p>REVISION DATE</p> <p>01/14</p>			

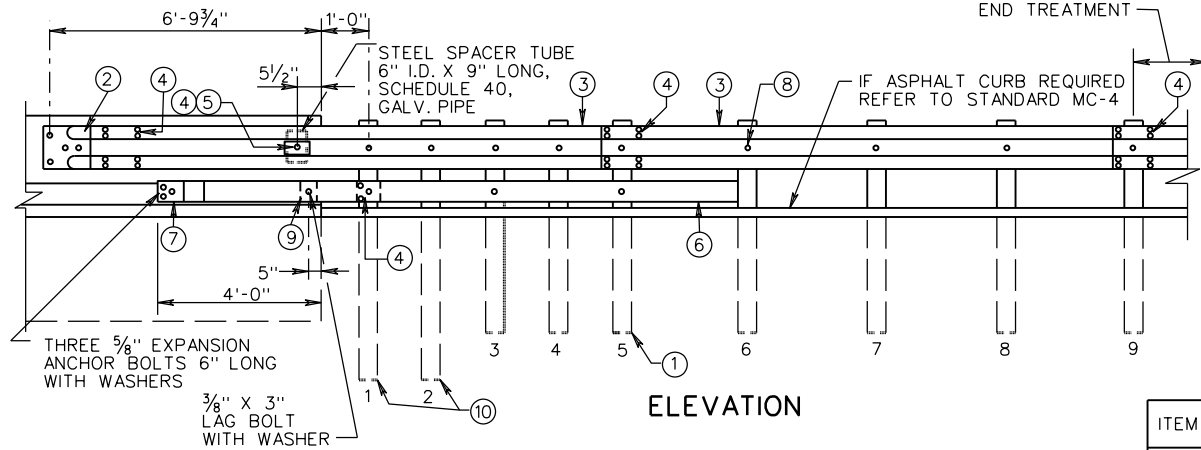
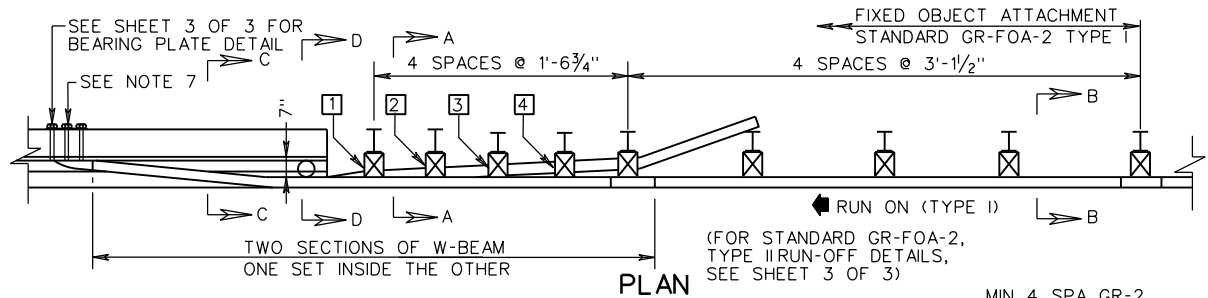

- NOTES:
1. FIXED OBJECTS MAY CONSIST OF SAFETY SHAPED BRIDGE PARAPETS OR CONCRETE BARRIERS.
 2. BRIDGE RAIL ENDS AND BRIDGE PARAPETS MUST BE OF ADEQUATE STRENGTH TO ACCEPT FULL IMPACT LOADING.
 3. GUARDRAIL COMPONENTS SHALL BE IN ACCORDANCE WITH VDOT ROAD AND BRIDGE STANDARDS.
 4. POSTS 1, 2, 3, 4, AND 5 REQUIRE AN ADDITIONAL HOLE TO ATTACH LOWER BLOCKS AND/OR RUBRAIL. RUBRAIL IS NOT BOLTED TO POSTS 2 AND 4.
 5. BOTTOM WOOD BLOCKS LOCATED ON POSTS 1 THROUGH 4 ARE CENTER DRILLED AND SECURED WITH 5/8" GUARDRAIL BOLTS. (LENGTH AS REQUIRED).
 6. RUBRAIL MUST BE TWISTED 35° BETWEEN SECTIONS C-C AND D-D. SHOP FABRICATION MAY BE REQUIRED. RIGHT HAND AND LEFT HAND TWISTS WILL BE NECESSARY.
 7. APPROPRIATE LENGTH 7/8" ASTM A449 HEX BOLTS WITH WASHERS MUST BE USED WITH THRU DRILLED HOLES AND A 5/8" BEARING PLATE ON THE BACK SIDE OF THE BRIDGE PARAPET OR CONCRETE BARRIER.
 8. SEE SHEET 3 OF 3 FOR RUBRAIL BLOCKOUT DETAILS.

TWO SECTIONS OF W-BEAM ONE SET INSIDE THE OTHER

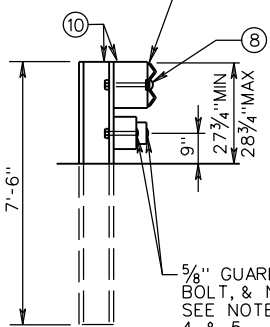

SECTION A-A

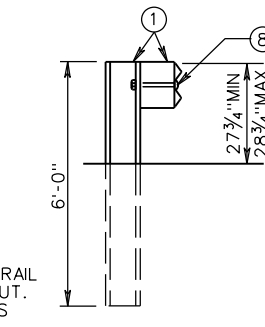

SECTION B-B

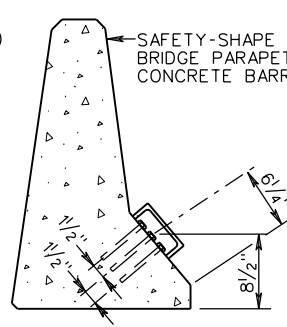

SECTION C-C
(W BEAM OMITTED)

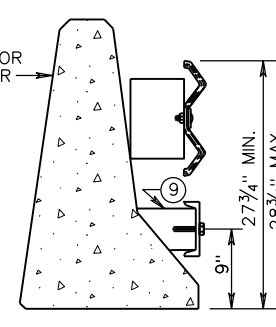

SECTION D-D

NEW BRIDGE - ATTACHMENTS
 ONE-WAY TRAFFIC-RUN-ON, 2-GR-FOA-2, TYPE I
 -RUN-OFF, 2-GR-FOA-2, TYPE II
 TWO-WAY TRAFFIC-RUN-ON, 4-GR-FOA-2, TYPE I
 EXISTING BRIDGE ATTACHMENTS AS SHOWN ON PLANS.

ITEM	MATERIAL/SPECIFICATIONS/NOTES
①	ST'D. W6 X 8.5 OR W6 X 9 STEEL POST W/ ST'D. 6" X 8" X 14" LG. TREATED PINE BLOCK OR RECYCLED MATERIAL
②	STANDARD W-BEAM TERMINAL CONNECTOR
③	STANDARD W-BEAM RAIL
④	5/8" X 2" LONG GUARDRAIL BOLT AND RECESSED NUT (SEE STANDARD GR-HDW)
⑤	RECTANGULAR PLATE WASHER (SEE STANDARD GR-HDW)
⑥	BENT PLATE RUBRAIL (SEE SHEET 3 OF 3)
⑦	C6 X 8.2 RUBRAIL (SEE SHEET 3 OF 3)
⑧	5/8" X 10" LONG GUARDRAIL BOLT AND RECESSED NUT
⑨	WOOD BLOCKOUT FOR RUBRAIL (SEE SHEET 3 OF 3)
⑩	W8 X 13 X 7'-6" LG. STEEL POST WITH STD. 6" X 8" X 14" LG. TREATED PINE BLOCK OR RECYCLED MATERIAL.

SPECIFICATION REFERENCE

505

A COPY OF THE ORIGINAL SEALED AND SIGNED DRAWING IS ON FILE IN THE CENTRAL OFFICE.
W-BEAM GUARDRAIL - FIXED OBJECT ATTACHMENT
 FOR USE WITH SAFETY SHAPE - (STEEL POSTS)

VIRGINIA DEPARTMENT OF TRANSPORTATION

VDOT

ROAD AND BRIDGE STANDARDS

REVISION DATE

01/14

SHEET 2 OF 3

501.29

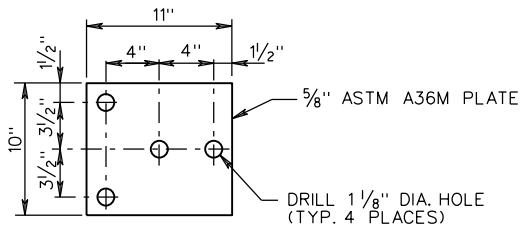

BEARING PLATE

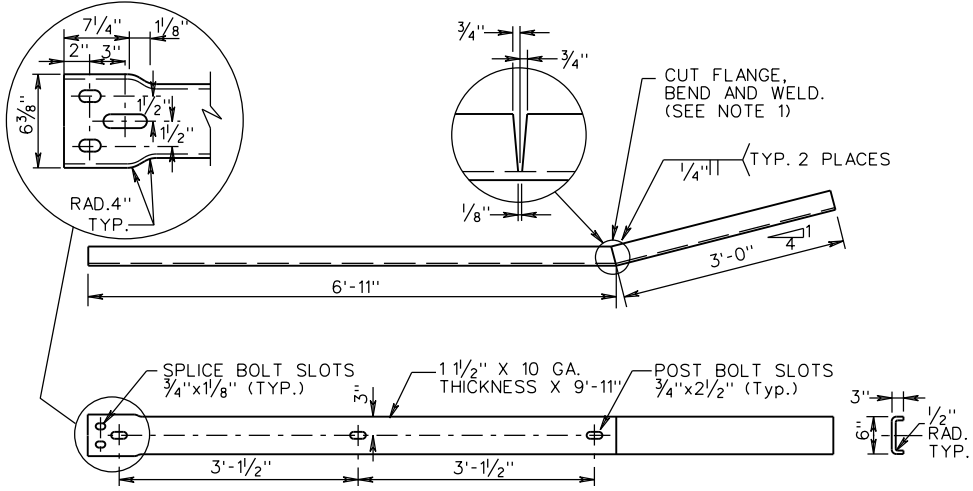
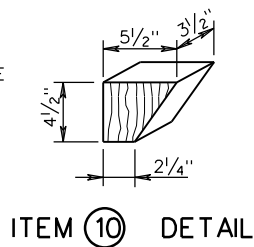

ITEM 7 DETAIL

TRIM FLANGES, BEND WEB AS SHOWN AND WELD (SEE NOTE 1)

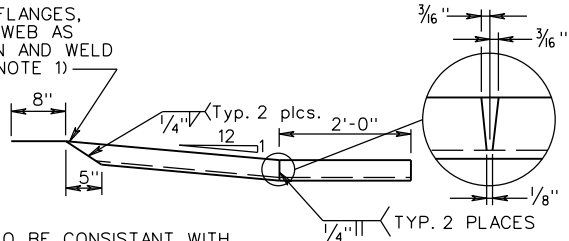

FABRICATE TO BE CONSISTANT WITH THE SLOPE OF THE PARAPET OR BARRIER AND ATTACH FLUSH TO SLOPE.

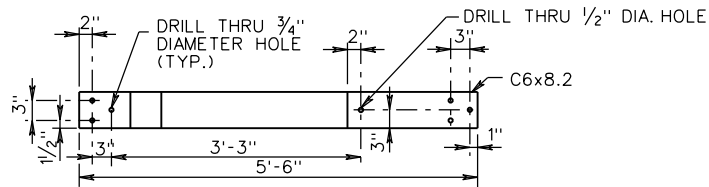

ITEM 8 DETAIL

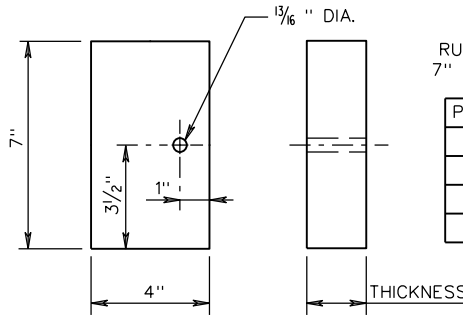

STEEL POSTS
RUBRAIL BLOCKOUTS
7" X 4" X THICKNESS

POST	THICKNESS
1	4 1/4"
2	3 1/4"
3	2"
4	1"

WOOD POSTS
RUBRAIL BLOCKOUTS
7" X 4" X THICKNESS

POST	THICKNESS
1	6 1/4"
2	4 5/8"
3	3 1/8"
4	1 1/2"

RUBRAIL BLOCKOUT DETAIL

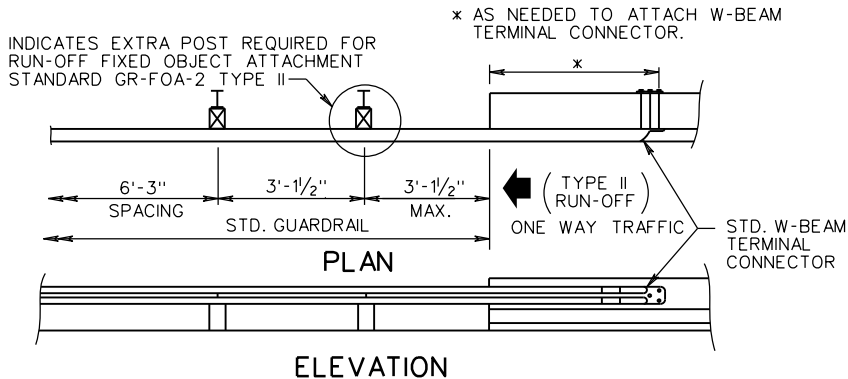

ELEVATION

NOTES:
1. CAN BE FIELD CUT AND BENT USING HEAT. IF SHOP CUT AND BENT, RIGHT HAND OR LEFT HAND MUST BE SPECIFIED DEPENDING ON WHICH SIDE OF THE ROADWAY THE TRANSITION IS USED.

A COPY OF THE ORIGINAL SEALED AND SIGNED DRAWING IS ON FILE IN THE CENTRAL OFFICE.
W-BEAM GUARDRAIL - FIXED OBJECT ATTACHMENT
RUBRAIL AND HARDWARE DETAILS

VIRGINIA DEPARTMENT OF TRANSPORTATION

SPECIFICATION REFERENCE

505



ROAD AND BRIDGE STANDARDS

SHEET 3 OF 3

REVISION DATE

501.30

01/14

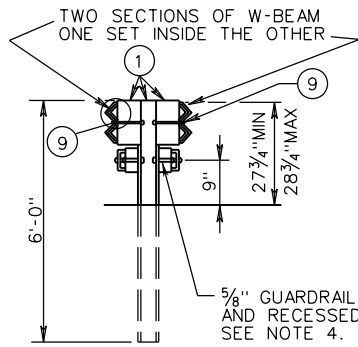
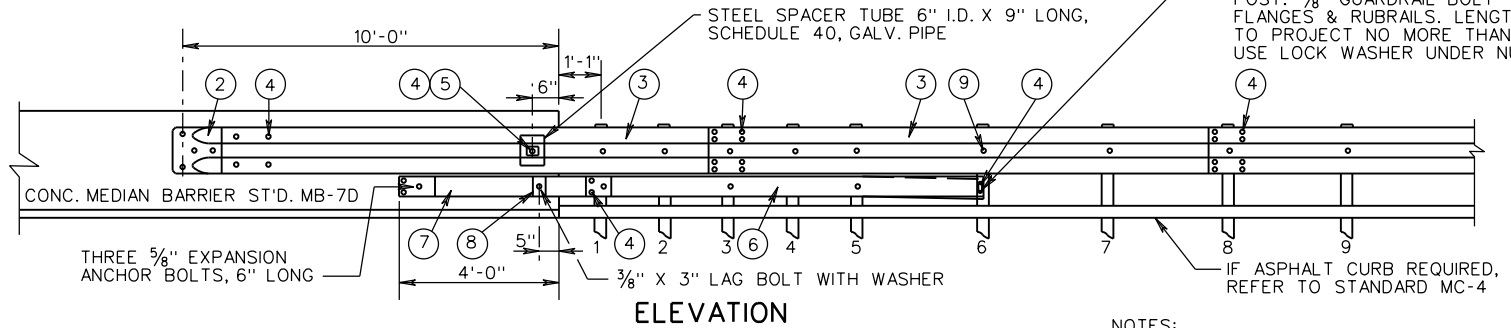
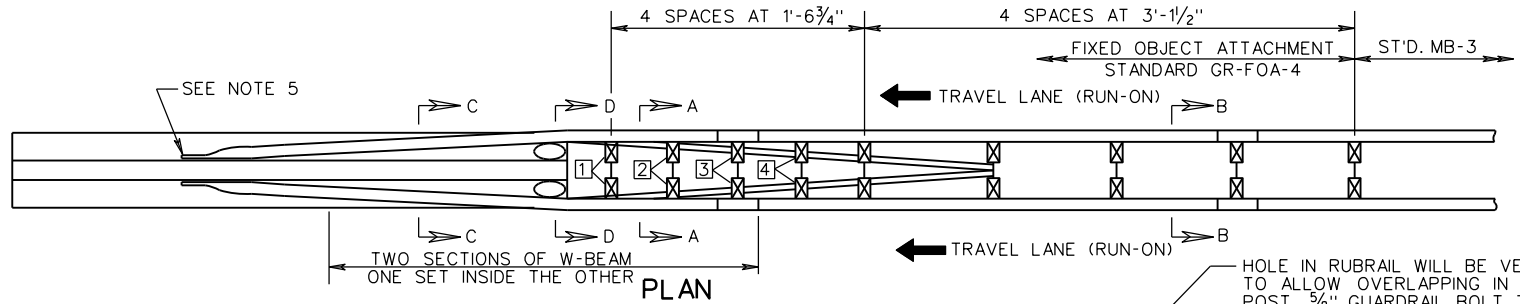

SECTION A-A

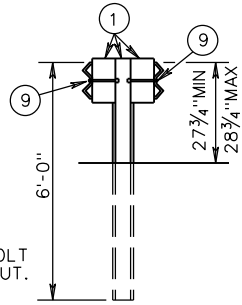

SECTION B-B

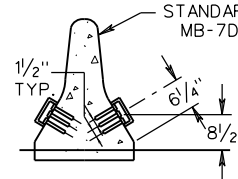

SECTION C-C
(W-BEAM OMITTED)

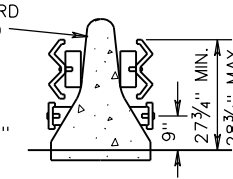

SECTION D-D

NOTES:

1. ALL GUARDRAIL POSTS ARE TO BE STEEL.
2. ALL GUARDRAIL COMPONENTS ARE TO BE IN ACCORDANCE WITH VDOT ROAD AND BRIDGE STANDARDS.
3. POSTS 1, 2, 3, 4 AND 5 REQUIRE AN ADDITIONAL HOLE TO ATTACH LOWER BLOCKS AND/OR RUBRAIL. RUBRAIL IS NOT BOLTED TO POSTS 2 AND 4.
4. BOTTOM WOOD BLOCKS LOCATED ON POSTS 1 THROUGH 4 ARE TO BE DRILLED AND SECURED WITH 5/8" GUARDRAIL BOLTS (LENGTH AS REQUIRED)
5. APPROPRIATE LENGTH 7/8" ASTM A449 HEX BOLTS WITH WASHERS ARE TO BE USED WITH HOLES DRILLED THROUGH THE CONCRETE MEDIAN BARRIER ATTACHING THE W-BEAM TERMINAL CONNECTORS ON EACH SIDE. BOLTS TO PROJECT NO MORE THAN 1/2" BEYOND NUTS. USE LOCK WASHERS UNDER NUTS.

TYPE I TWO RUN-ON SECTIONS (WITH 2 RUBRAILS SHOWN)

TYPE II ONE RUN-ON SECTION (WITH 1 RUBRAIL RETAINED)
ONE RUN-OFF SECTION (WITH 1 RUBRAIL REMOVED)

TYPE III TWO RUN-OFF SECTIONS (WITH 2 RUBRAILS REMOVED)

RUBRAIL WOOD BLOCKS 7" x 4"	
POST	THICKNESS
1	4 1/4"
2	3 3/4"
3	2"
4	1"

ITEM	MATERIALS/SPECIFICATIONS/NOTES	ITEM	MATERIALS/SPECIFICATIONS/NOTES
1	ST'D. W6 X 8.5 OR W6 X 9 STEEL POSTS, ST'D. 6" X 8" X 14" LONG TREATED PINE BLOCK OR RE-CYCLED MATERIAL.	5	RECTANGULAR PLATE WASHER (SEE STANDARD GR-HDW)
2	ST'D. W-BEAM TERMINAL CONNECTOR	6	BENT PLATE RUBRAIL (SEE SHEET 2 OF 2)
3	STANDARD W-BEAM RAIL	7	C6 x 8.2 RUBRAIL (SEE SHEET 2 OF 2)
4	5/8" X 2" LONG GUARDRAIL BOLT AND RECESSED NUT	8	WOOD BLOCKOUT FOR RUBRAIL (SEE SHEET 2 OF 2)
		9	5/8" X 10" LONG GUARDRAIL BOLT AND RECESSED NUT

A COPY OF THE ORIGINAL SEALED AND SIGNED DRAWING IS ON FILE IN THE CENTRAL OFFICE.

SPECIFICATION REFERENCE	505	<p>BLOCKED-OUT W-BEAM MEDIAN BARRIER-FIXED OBJECT ATTACHMENT (FOR USE BETWEEN STANDARD MB-7D AND STANDARD MB-3) VIRGINIA DEPARTMENT OF TRANSPORTATION</p>		<p>VDOT ROAD AND BRIDGE STANDARDS</p>
		REVISION DATE	SHEET 1 OF 2	
		01/14	501.31	

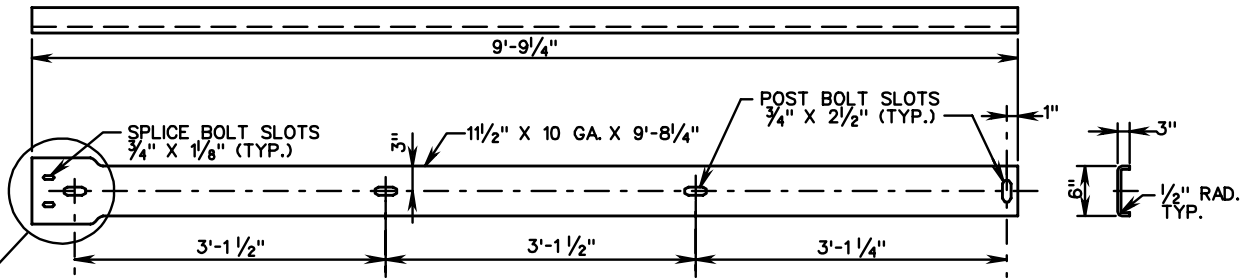

ITEM ⑦ DETAIL

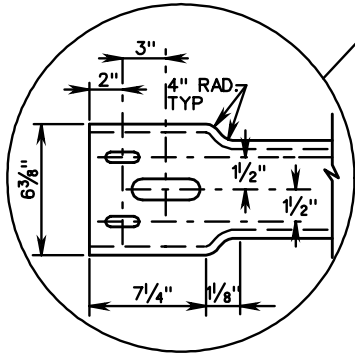

NOTES:

1. CAN BE FIELD CUT AND BENT USING HEAT. IF SHOP CUT AND BENT, RIGHT HAND OR LEFT HAND MUST BE SPECIFIED, DEPENDING ON WHICH SIDE OF THE ROADWAY THE TRANSITION IS USED.

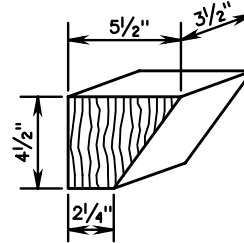

ITEM ⑨ DETAIL

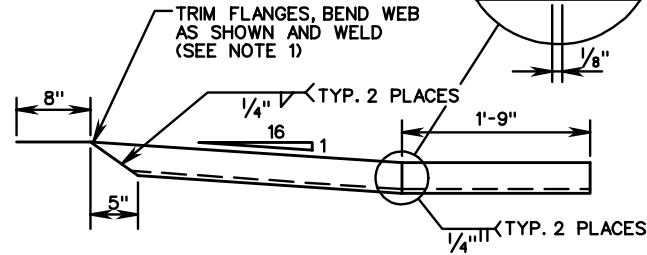
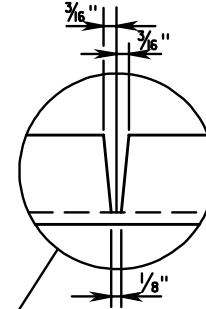

ITEM ⑧ DETAIL

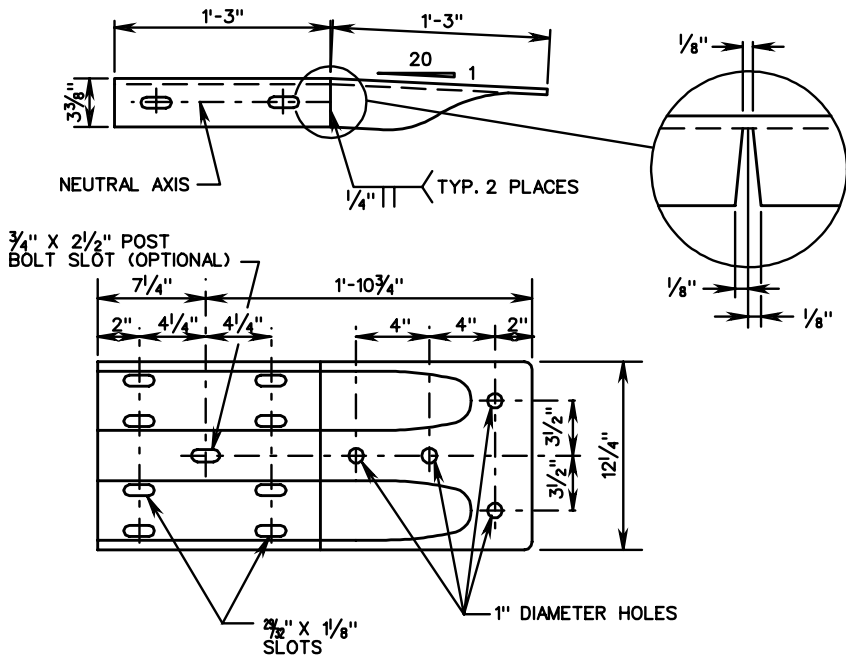

W BEAM TERMINAL CONNECTOR (MOD.)

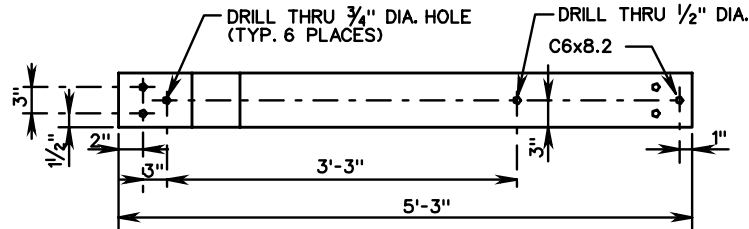

ROAD AND BRIDGE STANDARDS

**BLOCKED-OUT W-BEAM MEDIAN BARRIER
FIXED OBJECT ATTACHMENT**
(RUBRAIL AND HARDWARE DETAILS)
VIRGINIA DEPARTMENT OF TRANSPORTATION

SPECIFICATION
REFERENCE

SHEET 2 OF 2

REVISION DATE

505

501.32

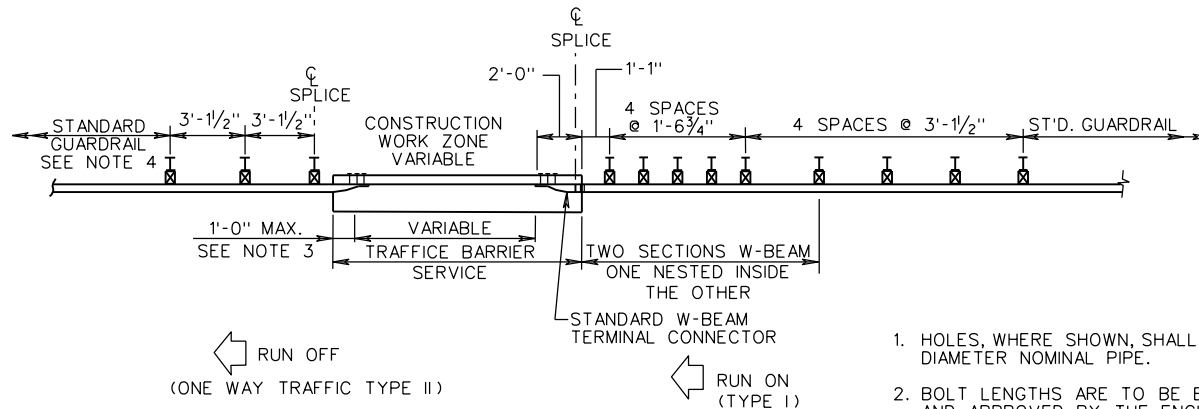

← RUN OFF
(ONE WAY TRAFFIC TYPE II)

← RUN ON
(TYPE I)

1. HOLES, WHERE SHOWN, SHALL BE FORMED WITH SLEEVES OF 1/2" DIAMETER NOMINAL PIPE.
2. BOLT LENGTHS ARE TO BE ESTABLISHED BY THE CONTRACTOR AND APPROVED BY THE ENGINEER. ALL BOLTS ARE TO BE 7/8" DIA. HEX HEAD MACHINE BOLTS WITH BEVELED WASHERS AND SELF-LOCKING NUTS.
3. FOR TWO-WAY TRAFFIC DESIGN, USE RUN-ON END TRANSITION (TYPE I).
4. RUN OFF (TYPE II) GUARDRAIL TO BE USED ONLY WHEN REQUIRED FOR OTHER REASONS.
5. COST OF TRANSITION TO BE INCLUDED IN PRICE BID PER FOOT OF TRAFFICE BARRIER SERVICE CONCRETE.
6. THESE INSTRUCTIONS APPLICABLE FOR TEMPORARY INSTALLATION IN CONSTRUCTION ZONES ONLY. REFER TO STANDARD GR-FOA FOR INSTRUCTIONS ON PERMANENT INSTALLATION.

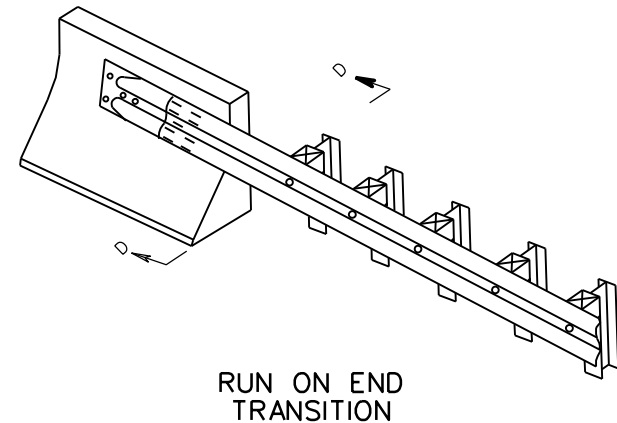
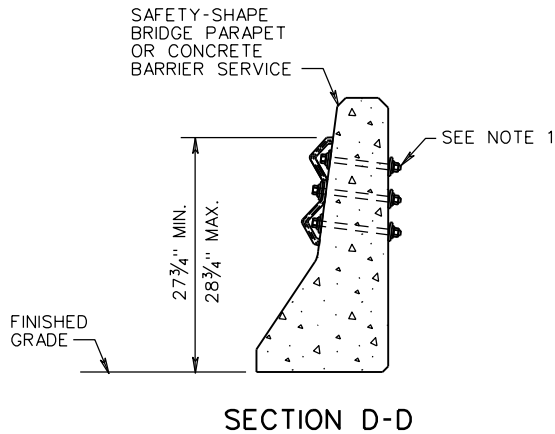

SPECIFICATION REFERENCE
505

W-BEAM GUARDRAIL INSTALLATION CRITERIA
FIXED OBJECT ATTACHMENT METHODS FOR CONSTRUCTION ZONES
 VIRGINIA DEPARTMENT OF TRANSPORTATION

VDOT ROAD AND BRIDGE STANDARDS	
REVISION DATE 7/11	SHEET 1 OF 1 501.33

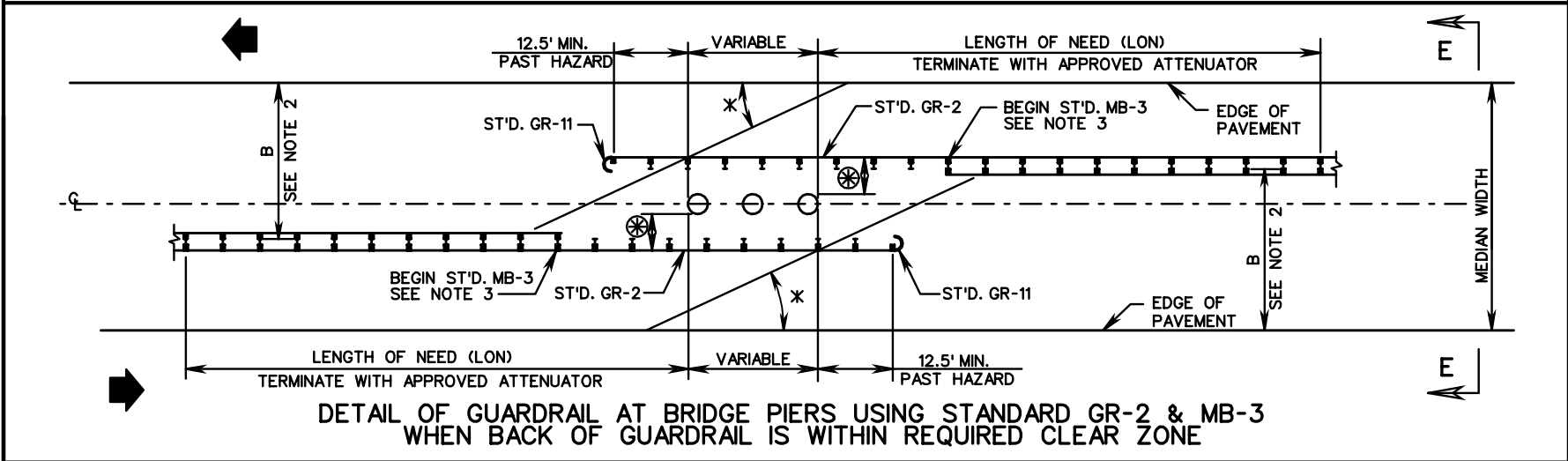
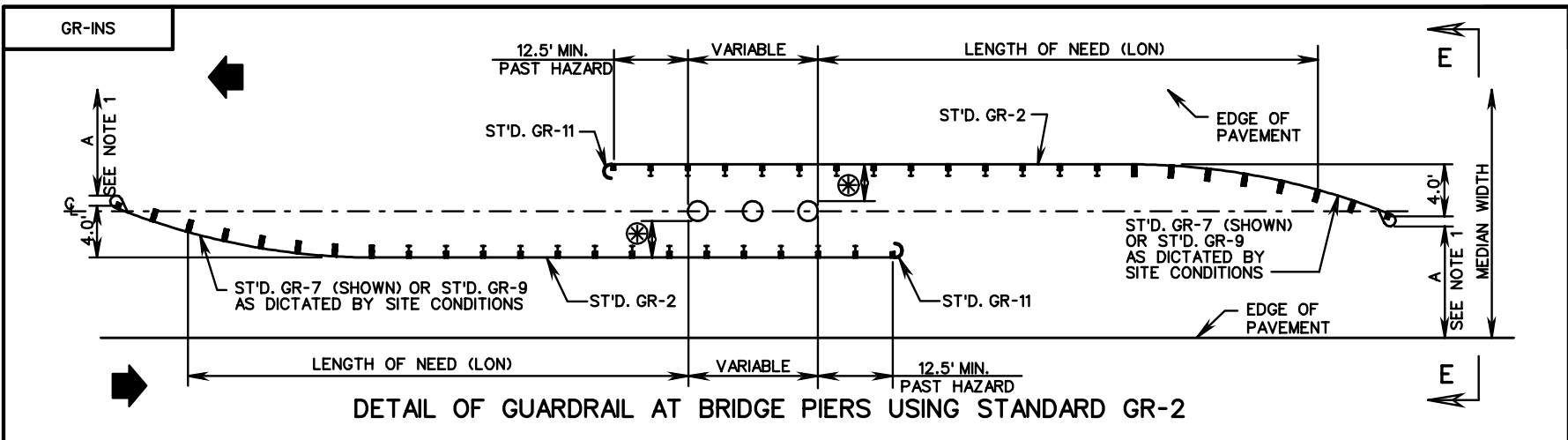

TYPICAL SECTION



SECTION E-E

⊗ GUARDRAIL SHALL BE PLACED SO THAT A HAZARD IS NOT WITHIN THE DEFLECTION LIMIT OF THE GUARDRAIL. THE GUARDRAIL DESIGN AND PLACEMENT SHOWN ABOVE MAY ALSO BE USED FOR SHIELDING AN OVERHEAD SIGN SUPPORT, FIXED OBJECTS OR OTHER TYPES OF ROAD SIDE OBSTRUCTIONS.

* 25° ANGLE OF VEHICLE DEPARTURE.

- NOTES:**
1. DISTANCE "A" MUST BE GREATER THAN REQ'D. CLEAR ZONE.
 2. DISTANCE "B" IS LESS THAN REQ'D. CLEAR ZONE.
 3. BEG IN ST'D MB-3 AT THE POST PRIOR TO THE POINT WHERE THE 25° ANGLE OF VEHICLE DEPARTURE WILL INTERSECT THE MB-3.

VDOT	
ROAD AND BRIDGE STANDARDS	
SHEET 1 OF 8	REVISION DATE
501.34	

W-BEAM GUARDRAIL INSTALLATION CRITERIA

VIRGINIA DEPARTMENT OF TRANSPORTATION

SPECIFICATION REFERENCE
221 505

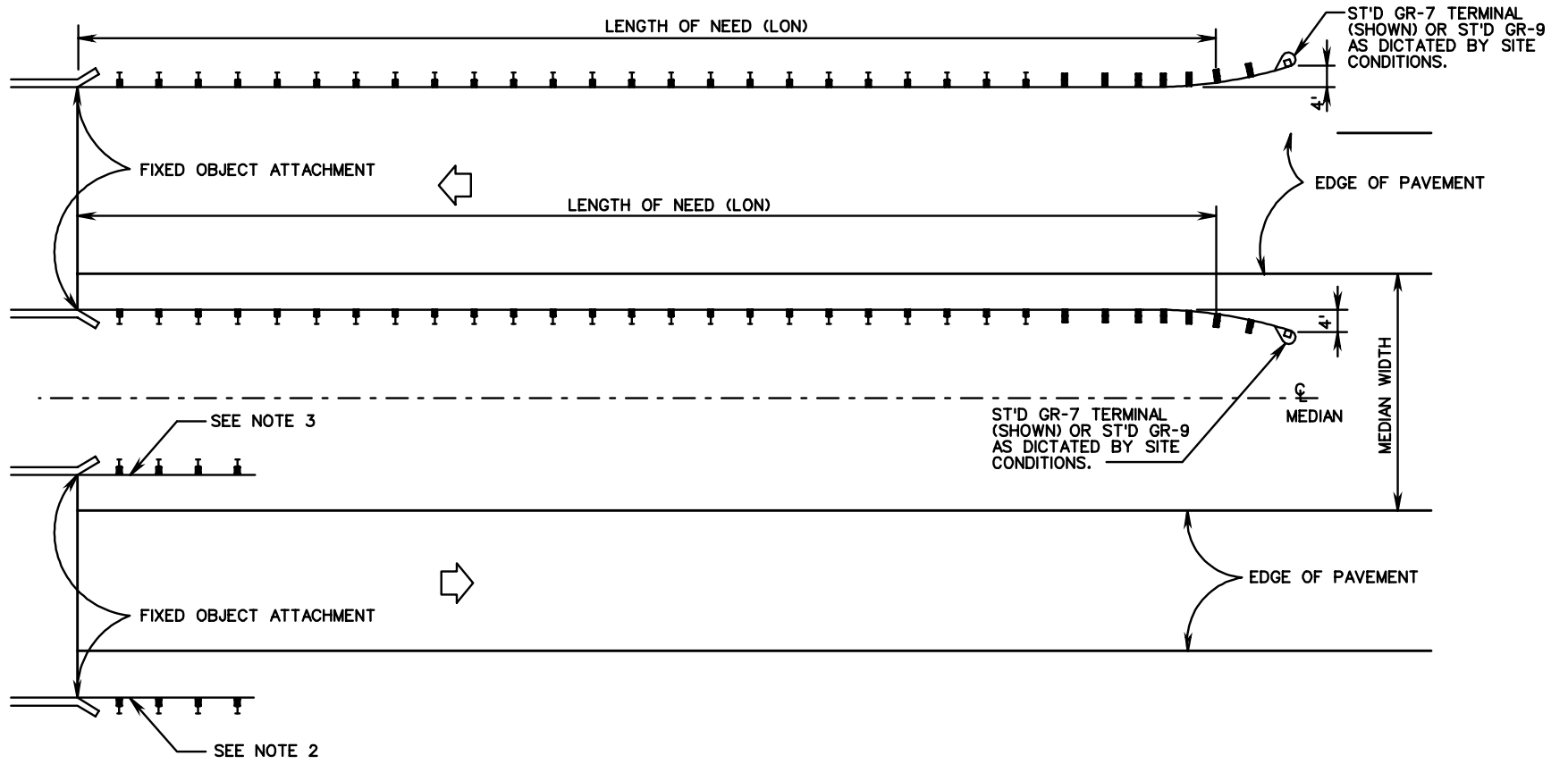

NOTES:

1. IF A CUT SECTION IS CLOSER THAN 200', A STANDARD GR-6 TERMINAL IS PREFERRED.
2. NO GUARDRAIL IS REQUIRED ON RUN-OFF UNLESS NEEDED TO SHIELD A HAZARD WITHIN THE REQUIRED CLEAR ZONE.
3. NO GUARDRAIL IS REQUIRED ON RUN-OFF UNLESS NEEDED TO SHIELD A HAZARD WITHIN THE REQUIRED CLEAR ZONE. REFER TO SHEET 501.34 IF BACK OF GUARDRAIL FROM THE OPPOSING LANES IS WITHIN THE REQUIRED CLEAR ZONE.

DETAIL OF GUARDRAIL AT DUAL BRIDGES

<p>SPECIFICATION REFERENCE</p>	<h2 style="margin: 0;">W-BEAM GUARDRAIL INSTALLATION CRITERIA</h2> <p style="margin: 0;">VIRGINIA DEPARTMENT OF TRANSPORTATION</p>	<p>VDOT</p> <p>ROAD AND BRIDGE STANDARDS</p>				
<p>221 505</p>		<table border="1" style="width: 100%; border-collapse: collapse;"> <tr> <td style="width: 50%;">REVISION DATE</td> <td style="width: 50%;">SHEET 2 OF 8</td> </tr> <tr> <td colspan="2" style="text-align: center;">501.35</td> </tr> </table>	REVISION DATE	SHEET 2 OF 8	501.35	
REVISION DATE	SHEET 2 OF 8					
501.35						

GR-INS

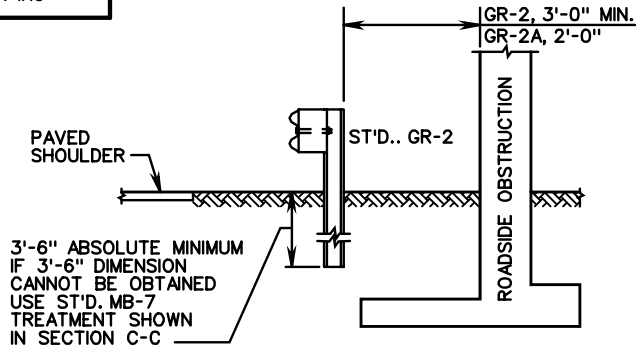

SECTION A-A

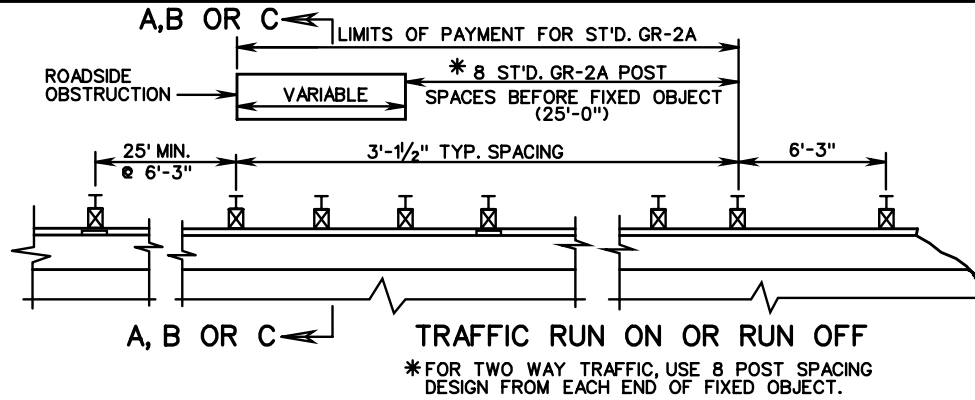

FOR USE WHERE DISTANCE FROM BACK OF GR-2A POST TO FIXED OBJECT IS LESS THAN 2'-0".

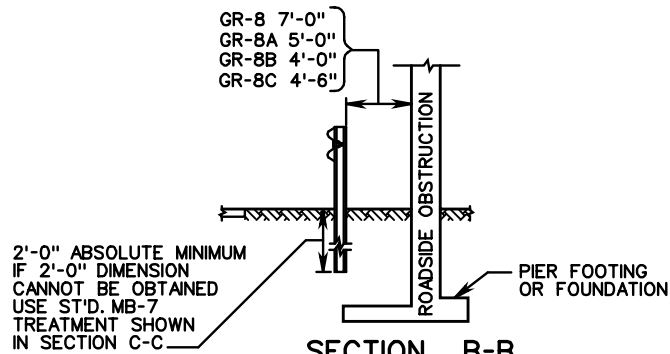

SECTION B-B

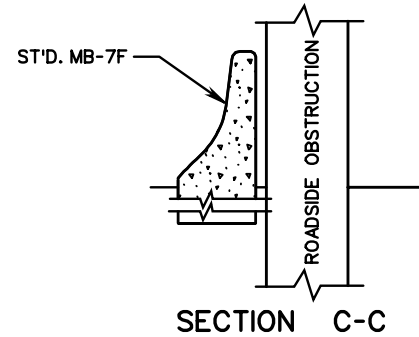

SECTION C-C

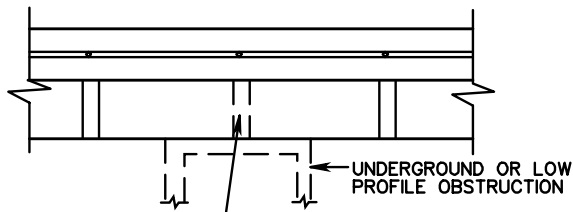

DETAIL OF SPECIAL DESIGN SITUATION

NOTE: IF GROUND LEVEL OR UNDERGROUND FIXED OBJECT NECESSITATES THE ELIMINATION OF ONE OR MORE POSTS, A GR-10 OR A SPECIAL DESIGN WILL BE REQUIRED

ONE OR MORE POSTS AS REQUIRED TO AVOID OBJECT

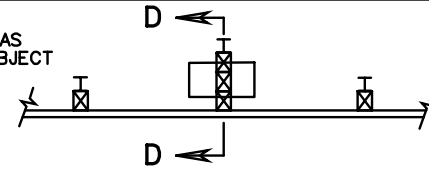

COST OF ADDITIONAL BLOCKOUT BRACKETS TO BE INCLUDED IN PRICE BID PER LINEAR FOOT OF GUARDRAIL.

3 BLOCKOUTS (MAX.) FOR ONE POST ONLY. TWO BLOCKOUTS MAY BE USED FOR A SERIES OF POSTS.



SECTION D-D
DETAIL OF MULTIPLE BLOCK-OUT TO AVOID UNDERGROUND OR LOW PROFILE OBSTRUCTION



ROAD AND BRIDGE STANDARDS

W BEAM GUARDRAIL INSTALLATION CRITERIA

SPECIFICATION REFERENCE

SHEET 3 OF 8

REVISION DATE

VIRGINIA DEPARTMENT OF TRANSPORTATION

501.36

221
505

NOTES:

GUARDRAIL INSTALLATION CRITERIA AS SHOWN ON THESE SHEETS IS TO APPLY TO THOSE LOCATIONS WHERE GUARDRAIL HAS TO BE TRANSITIONED FROM THE NORMAL LOCATION.

LENGTH OF TRANSITION (L) IS TO BE IN ACCORDANCE WITH TABLE III OR IV FOR APPLICABLE VALUES OF W OR AS DIRECTED BY THE ENGINEER.

RAIL TERMINAL SECTIONS IN ACCORDANCE WITH STANDARD GR-6, GR-7 OR GR-8 ARE TO BE INSTALLED AT EACH TERMINUS OF GUARDRAIL WHERE SPECIFIED ON PLANS.

ALL LENGTHS (L) ARE APPLIED ALONG FACE OF GUARDRAIL.

OFFSETS SHOWN IN TABLES ARE FOR 6'-3" SPACING. FOR 12'-6" SPACING (GR-8) USE EVERY SECOND VALUE FOR Y.

INSTALLATION METHODS SHOWN ON THESE SHEETS ARE APPLICABLE TO STANDARD PLANS GR-2, GR-2A AND GR-8.

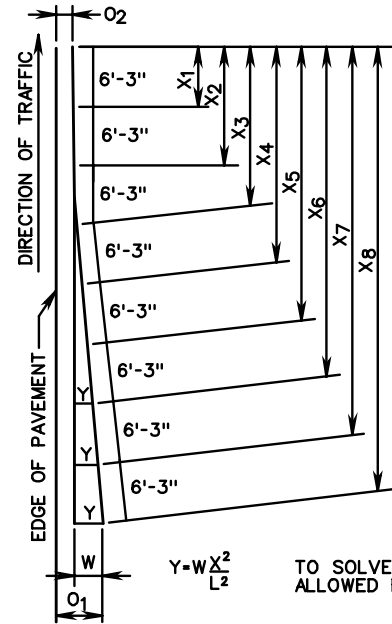

W = TOTAL LATERAL TRANSITION OF GUARDRAIL O1- O2
 O1 = OFFSET FROM EDGE OF PAVEMENT TO FACE OF GUARDRAIL MAX.
 O2 = OFFSET FROM EDGE OF PAVEMENT TO FACE OF GUARDRAIL MIN.
 X1 = ...Xn CUMULATIVE DISTANCE IN INCREMENTS OF 6'-3" FROM FIRST GUARDRAIL POST MEASURED ALONG FACE OF GUARDRAIL.
 Y = LATERAL OFFSET FROM FACE OF GUARDRAIL OF POST NEAREST TO PAVEMENT EDGE TO FACE OF GUARDRAIL AT EACH SUCCESSIVE POST.
 L = TOTAL LENGTH OF TRANSITIONAL PORTION OF GUARDRAIL.

TO SOLVE FOR "Y", USE THE MAXIMUM "L" ALLOWED FOR THE APPROPRIATE "W".

**TABLE III
 OFFSETS (Y) FOR INTRODUCED GUARDRAIL TRANSITIONS**

LENGTH L IN FEET	X IN FEET	W																		
		W-2'	W-3'	W-4'	W-5'	W-6'	W-7'	W-8'	W-9'	W-10'	W-11'	W-12'	W-13'	W-14'	W-15'	W-16'	W-17'	W-18'	W-19'	W-20'
37.50	X1 6.25	0.06	0.05	0.03	0.02	0.02	0.01	0.01	0.02	0.02	0.02	0.02	0.02	0.02	0.03	0.03	0.03	0.03	0.03	0.03
	X2 12.50	0.22	0.19	0.11	0.08	0.06	0.05	0.06	0.06	0.07	0.08	0.09	0.10	0.10	0.11	0.12	0.13	0.13	0.13	0.14
	X3 18.75	0.50	0.42	0.25	0.18	0.14	0.11	0.12	0.14	0.16	0.17	0.19	0.20	0.22	0.23	0.25	0.27	0.28	0.30	0.31
	X4 25.00	0.89	0.75	0.44	0.31	0.24	0.19	0.22	0.25	0.28	0.31	0.33	0.36	0.39	0.42	0.44	0.47	0.50	0.53	0.56
	X5 31.25	1.39	1.17	0.69	0.49	0.38	0.30	0.35	0.39	0.43	0.48	0.52	0.56	0.61	0.65	0.69	0.74	0.78	0.82	0.87
	X6 37.50	2.00	1.69	1.00	0.70	0.54	0.44	0.50	0.56	0.62	0.69	0.75	0.81	0.87	0.94	1.00	1.06	1.13	1.19	1.25
50.00	X7 43.75		2.30	1.36	0.96	0.74	0.60	0.68	0.77	0.85	0.94	1.02	1.11	1.19	1.28	1.36	1.45	1.53	1.62	1.70
	X8 50.00		3.00	1.78	1.25	0.96	0.78	0.89	1.00	1.11	1.22	1.33	1.44	1.56	1.67	1.78	1.89	2.00	2.11	2.22
	X9 56.25			2.25	1.58	1.22	0.98	1.12	1.27	1.41	1.55	1.69	1.83	1.97	2.11	2.25	2.39	2.53	2.67	2.81
75.00	X10 62.50			2.78	1.95	1.50	1.22	1.39	1.56	1.74	1.91	2.08	2.26	2.43	2.60	2.78	2.95	3.13	3.30	3.47
	X11 68.75			3.36	2.36	1.82	1.47	1.68	1.89	2.10	2.31	2.52	2.73	2.94	3.15	3.36	3.57	3.78	3.99	4.20
	X12 75.00			4.00	2.81	2.16	1.75	2.00	2.25	2.50	2.75	3.00	3.25	3.50	3.75	4.00	4.25	4.50	4.75	5.00
87.50	X13 82.25				3.30	2.54	2.05	2.35	2.64	2.93	3.23	3.52	3.81	4.11	4.40	4.69	4.99	5.28	5.57	5.87
	X14 87.50				3.83	2.94	2.38	2.72	3.06	3.40	3.74	4.08	4.42	4.76	5.10	5.44	5.78	6.13	6.47	6.81
100.00	X15 93.75				4.39	3.38	2.73	3.12	3.52	3.91	4.30	4.69	5.08	5.47	5.86	6.25	6.64	7.03	7.42	7.81
	X16 100.00				5.00	3.84	3.11	3.56	4.00	4.44	4.89	5.33	5.78	6.22	6.67	7.11	7.56	8.00	8.44	8.89
	X17 106.25					4.33	3.51	4.01	4.52	5.02	5.52	6.02	6.52	7.02	7.53	8.03	8.53	9.03	9.53	10.03
125.00	X18 112.50					4.86	3.94	4.50	5.06	5.62	6.19	6.75	7.31	7.87	8.44	9.00	9.56	10.13	10.69	11.25
	X19 118.75					5.41	4.39	5.01	5.64	6.27	6.89	7.52	8.15	8.77	9.40	10.03	10.65	11.28	11.91	12.53
	X20 125.00					6.00	4.86	5.56	6.25	6.94	7.64	8.33	9.03	9.72	10.42	11.11	11.81	12.50	13.19	13.89
150.00	X21 131.25						5.36	6.12	6.89	7.66	8.42	9.19	9.95	10.72	11.48	12.25	13.02	13.78	14.55	15.31
	X22 137.50						5.88	6.72	7.56	8.40	9.24	10.08	10.92	11.76	12.60	13.44	14.28	15.13	15.97	16.81
	X23 143.75						6.43	7.35	8.27	9.18	10.10	11.02	11.94	12.86	13.78	14.69	15.61	16.53	17.45	18.37
	X24 150.00						7.00	8.00	9.00	10.00	11.00	12.00	13.00	14.00	15.00	16.00	17.00	18.00	19.00	20.00

SPECIFICATION REFERENCE

221
505

W-BEAM GUARDRAIL INSTALLATION CRITERIA

VIRGINIA DEPARTMENT OF TRANSPORTATION



ROAD AND BRIDGE STANDARDS

REVISION DATE

SHEET 4 OF 8

501.37

GR-INS

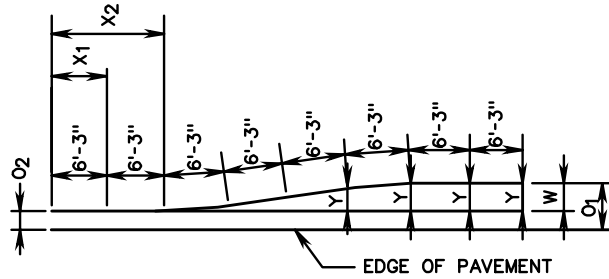

NOTE:
 GUARDRAIL INSTALLATION CRITERIA AS SHOWN ON THESE SHEETS IS TO APPLY TO THOSE LOCATIONS WHERE GUARDRAIL HAS TO BE TRANSITIONED FROM THE NORMAL LOCATION.

LENGTH OF TRANSITION (L) IS TO BE IN ACCORDANCE WITH TABLE III OR IV FOR APPLICABLE VALUES OF W OR AS DIRECTED BY THE ENGINEER.

RAIL TERMINAL SECTIONS IN ACCORDANCE WITH STANDARD GR-6, GR-7 OR GR-8 ARE TO BE INSTALLED AT EACH TERMINUS OF GUARDRAIL WHERE SPECIFIED ON PLANS.

ALL LENGTHS (L) ARE APPLIED ALONG FACE OF GUARDRAIL.

OFFSETS SHOWN IN TABLES ARE FOR 6'-3" SPACING, FOR 12'-6" SPACING (GR-8) USE EVERY SECOND VALUE OF Y.

INSTALLATION METHODS SHOWN ON THESE SHEETS ARE APPLICABLE TO STANDARD PLANS GR-2, GR-2A AND GR-8.

TABLE IV
OFFSETS (Y) FOR CONTINUOUS RUN-ON GUARDRAILS AND ALL RUN-OFF TRANSITIONS

LENGTH L IN FEET	X IN FEET	W-2'		W-3'		W-4'		W-5'		W-6'		W-7'		W-8'		W-9'		W-10'		W-11'		W-12'	
		RUN ON	RUN OFF	RUN ON	RUN OFF	RUN ON	RUN OFF	RUN ON	RUN OFF	RUN ON	RUN OFF	RUN ON	RUN OFF	RUN ON	RUN OFF	RUN ON	RUN OFF	RUN ON	RUN OFF	RUN ON	RUN OFF	RUN ON	RUN OFF
37.50	X ₁ 6.25	0.04	0.04	0.02	0.02	0.00	0.00	0.00	0.00	0.00	0.01	0.00	0.01	0.00	0.01	0.00	0.01	0.00	0.01	0.00	0.01	0.00	0.01
	X ₂ 12.50	0.30	0.30	0.19	0.19	0.03	0.03	0.02	0.04	0.01	0.05	0.01	0.05	0.01	0.06	0.01	0.07	0.01	0.08	0.01	0.09	0.01	0.09
	X ₃ 18.75	1.00	1.00	0.63	0.63	0.11	0.11	0.07	0.13	0.05	0.16	0.03	0.18	0.03	0.21	0.03	0.24	0.03	0.26	0.04	0.29	0.04	0.32
	X ₄ 25.00	1.70	1.70	1.50	1.50	0.25	0.25	0.16	0.31	0.11	0.38	0.08	0.44	0.06	0.50	0.07	0.56	0.08	0.63	0.09	0.69	0.09	0.75
	X ₅ 31.25	1.96	1.96	2.37	2.37	0.49	0.49	0.31	0.61	0.22	0.73	0.16	0.85	0.12	0.98	0.14	1.10	0.15	1.22	0.17	1.34	0.18	1.46
	X ₆ 37.50	2.00	2.00	2.81	2.81	0.84	0.84	0.54	1.05	0.38	1.27	0.28	1.48	0.21	1.69	0.24	1.90	0.26	2.11	0.29	2.32	0.32	2.53
50.00	X ₇ 43.75			2.98	2.98	1.34	1.34	0.86	1.67	0.60	2.01	0.44	2.34	0.33	2.68	0.38	3.01	0.42	3.35	0.46	3.68	0.50	4.02
	X ₈ 50.00			3.00	3.00	2.00	2.00	1.28	2.50	0.89	3.00	0.65	3.50	0.50	4.00	0.56	4.50	0.63	5.00	0.69	5.50	0.75	6.00
100.00	X ₉ 56.25					2.66	2.66	1.82	3.33	1.27	3.99	0.93	4.66	0.71	5.32	0.80	5.99	0.89	6.65	0.98	7.32	1.07	7.98
	X ₁₀ 62.50					3.16	3.16	2.50	3.95	1.74	4.73	1.28	5.52	0.98	6.31	1.10	7.10	1.22	7.89	1.34	8.68	1.46	9.47
	X ₁₁ 68.75					3.51	3.51	3.18	4.39	2.31	5.27	1.70	6.15	1.30	7.02	1.46	7.90	1.62	8.78	1.79	9.66	1.95	10.54
	X ₁₂ 75.00					3.75	3.75	3.72	4.69	3.00	5.63	2.20	6.56	1.69	7.50	1.90	8.44	2.11	9.38	2.32	10.31	2.53	11.25
	X ₁₃ 81.25					3.89	3.89	4.14	4.87	3.69	5.84	2.80	6.82	2.15	7.79	2.41	8.76	2.68	9.74	2.95	10.71	3.22	11.68
	X ₁₄ 87.50					3.97	3.97	4.46	4.96	4.26	5.95	3.50	6.95	2.68	7.94	3.01	8.93	3.35	9.92	3.68	10.91	4.02	11.91
	X ₁₅ 93.75					4.00	4.00	4.69	5.00	4.73	5.99	4.20	6.99	3.30	7.99	3.71	8.99	4.12	9.99	4.53	10.99	4.94	11.99
	X ₁₆ 100.00					4.00	4.00	4.84	5.00	5.11	6.00	4.80	7.00	4.00	8.00	4.50	9.00	5.00	10.00	5.50	11.00	6.00	12.00
125.00	X ₁₇ 106.25							4.93	5.40	5.30	6.30	4.70	5.70	4.70	5.29	5.88	6.47	7.06					
	X ₁₈ 112.50							4.98	5.63	5.72	6.35	5.32	5.99	5.99	6.65	7.32	7.98						
	X ₁₉ 118.75							5.00	5.78	6.07	6.35	6.31	7.10	7.10	7.89	8.68	9.47						
	X ₂₀ 125.00							5.00	5.89	6.35	6.31	7.10	7.89	8.68	9.47								
150.00	X ₂₁ 131.25								5.95	6.56	6.70	7.54	7.54	8.38	9.21	10.05							
	X ₂₂ 137.50								5.99	6.72	7.02	7.90	7.90	8.78	9.66	10.54							
	X ₂₃ 143.75								6.00	6.84	7.29	8.20	8.20	9.11	10.02	10.93							
	X ₂₄ 150.00								6.00	6.92	7.50	8.44	8.44	9.38	10.31	11.25							
175.00	X ₂₅ 156.25									6.97	7.67	8.62	9.58	9.58	10.54	11.50							
	X ₂₆ 162.50									6.99	7.79	8.76	9.74	9.74	10.71	11.68							
	X ₂₇ 168.75									7.00	7.88	8.86	9.85	9.85	10.83	11.82							
	X ₂₈ 175.00									7.00	7.94	8.93	9.92	9.92	10.91	11.91							
200.00	X ₂₉ 181.25										7.97	8.97	9.97	9.97	10.96	11.96							
	X ₃₀ 187.50										7.99	8.99	9.99	9.99	10.99	11.99							
	X ₃₁ 193.75										8.00	9.00	10.00	10.00	11.00	12.00							
	X ₃₂ 200.00										8.00	9.00	10.00	10.00	11.00	12.00							



ROAD AND BRIDGE STANDARDS

SHEET 5 OF 8

REVISION DATE

501.38

W-BEAM GUARDRAIL INSTALLATION CRITERIA

VIRGINIA DEPARTMENT OF TRANSPORTATION

SPECIFICATION REFERENCE

221
505

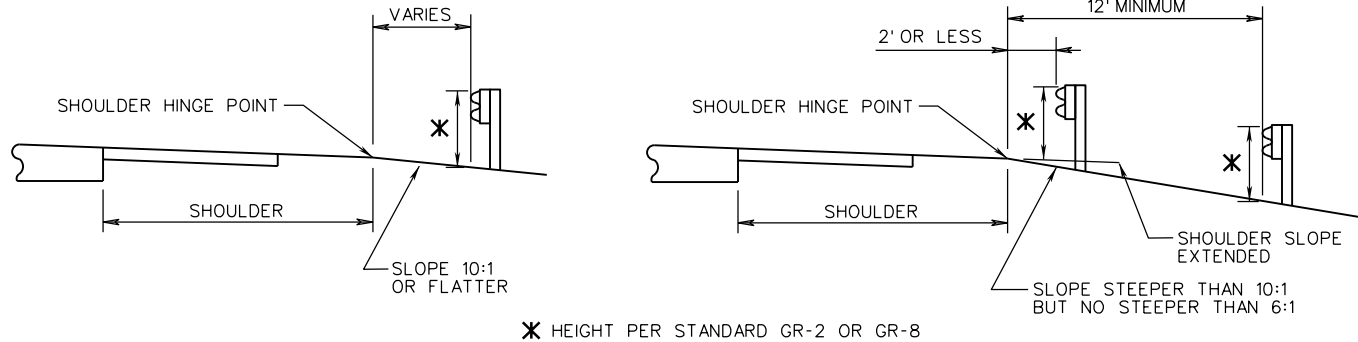

MEASURING GUARDRAIL HEIGHT ON FRONT SLOPE RELATIVE TO SHOULDER HINGE POINT

FACE OF GUARDRAIL IS TO BE ALIGNED WITH FACE OF CURB.
 DESIGN SPEED > 45 MPH
 USE GR-2A

DESIGN SPEED ≤ 45 MPH
 USE GR-2.

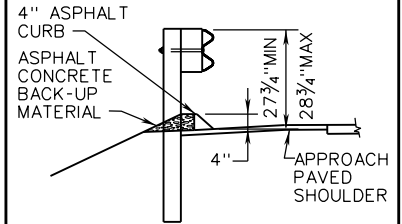

ASPHALT CURB SECTION

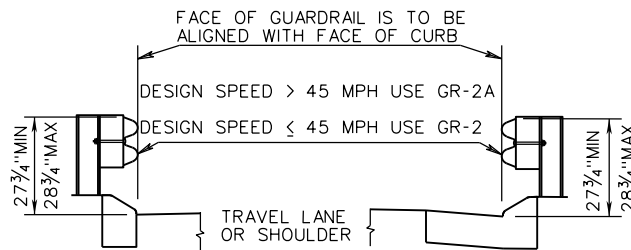

GR-2 INSTALLATION WITH CG-3 OR CG-7 CURB

FOR GUARDRAIL DESIGN POLICIES USING CURB & GUTTER OR URBAN DESIGNS WITH SIDEWALK OR SIDEWALK SPACE SEE APPENDIX I OF THE ROAD DESIGN MANUAL

TABLE I
 NORMAL GUARDRAIL LOCATION-THROUGH TRAFFIC LANES LEFT OF TRAFFIC

TOTAL SHOULDER WIDTH (S) (PAVED & GRADED)	PAVED SHOULDER WIDTH (P _S) (SEE NOTE)	OFFSET FROM EDGE OF TRAVELED WAY TO FACE OF GUARDRAIL (O)
17'	12'	14'
15'	3', 4', or 10'	12'
13'	3', 4', or 8'	10'
11'	3' or 4'	8'
9'	3' or 4'	6'
8'	3' or 4'	5'
7'	0 or 2'	4'
5'	0	2'

TABLE II
 NORMAL GUARDRAIL LOCATION-THROUGH TRAFFIC LANES RIGHT OF TRAFFIC

TOTAL SHOULDER WIDTH (S) (PAVED & GRADED)	PAVED SHOULDER WIDTH (P _S) (SEE NOTE)	OFFSET FROM EDGE OF TRAVELED WAY TO FACE OF GUARDRAIL (O)
17'	12'	14'
15'	6' or 10'	12'
13'	8'	10'
11'	3', 4' or 6'	8'
9'	0, 3', or 4'	6'
8'	0 or 3'	5'
7'	0 or 2'	4'
5'	0	2'

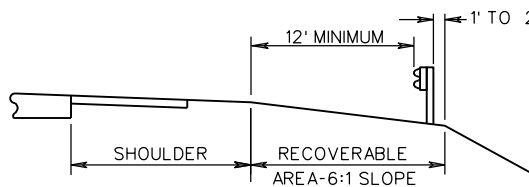

GUARDRAIL LOCATION ON RECOVERABLE SLOPE

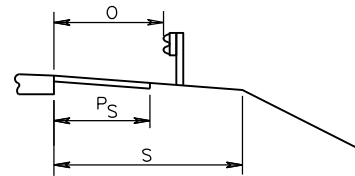

NOTE:
 PAVED SHOULDER WIDTHS SHOWN ARE MINIMUM. THE PAVED SHOULDER MAY BE EXTENDED TO THE FACE OF THE RAIL THE PAVED WIDTH USED SHALL BE IN ACCORDANCE WITH THE ROADWAY CLASSIFICATION AS DEFINED IN THE ROAD DESIGN MANUAL.

SEE STANDARD MC-4 FOR PAVING UNDER GUARDRAIL.

NORMAL GUARDRAIL LOCATION

SPECIFICATION REFERENCE

221
 505

A COPY OF THE ORIGINAL SEALED AND SIGNED DRAWING IS ON FILE IN THE CENTRAL OFFICE.

W-BEAM GUARDRAIL INSTALLATION CRITERIA

VIRGINIA DEPARTMENT OF TRANSPORTATION



ROAD AND BRIDGE STANDARDS

REVISION DATE

07/15

SHEET 6 OF 8

501.39

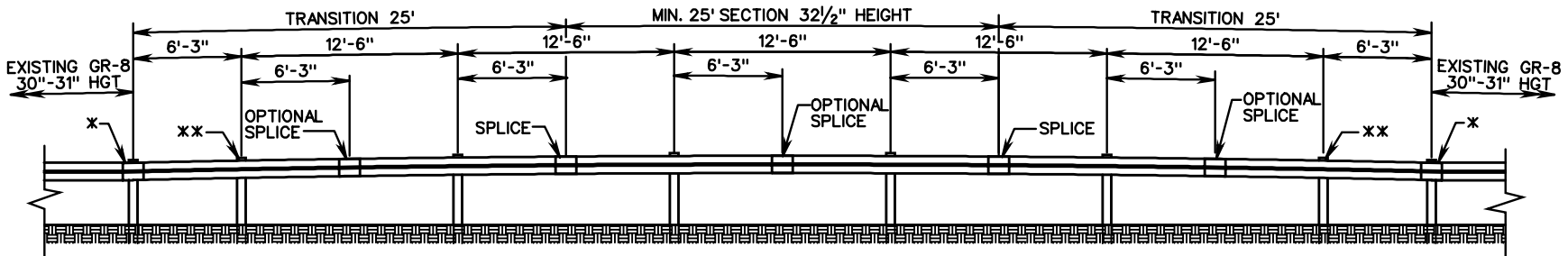
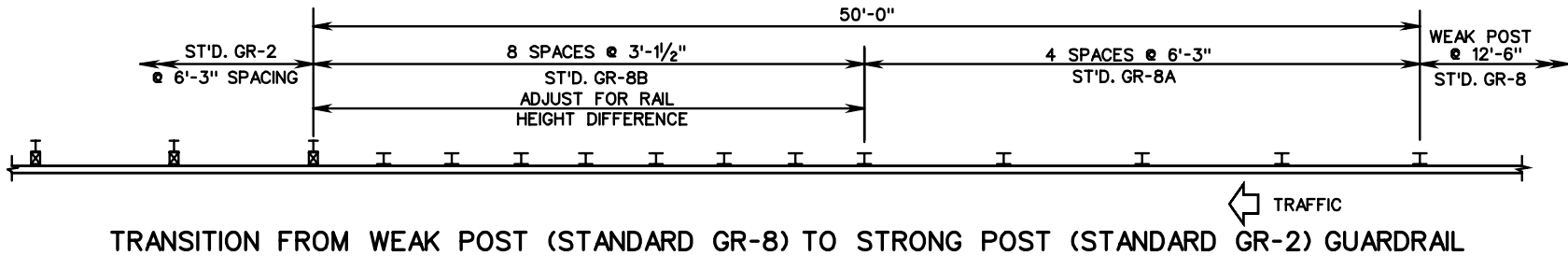
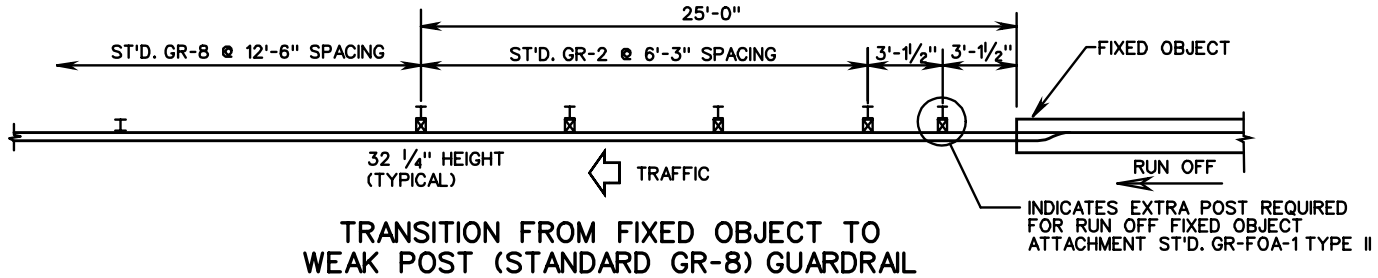
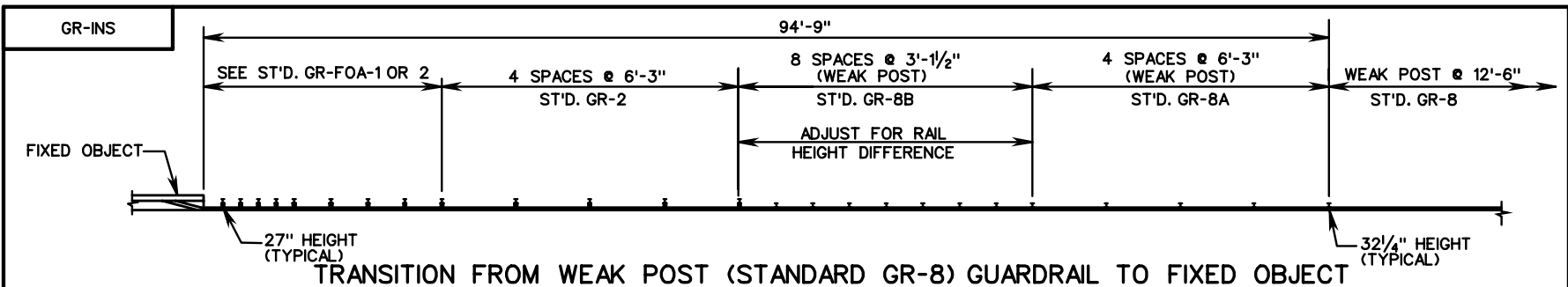

* PLACE A SPLICE AT THE LAST POST OF THE EXISTING GR-8. THEN USE A 25 FT. TRANSITION SECTION OF RAIL TO ANOTHER SPLICE. THIS WILL RAISE THE GUARDRAIL HEIGHT FROM THE OLD GR-8 (30"-31") TO THE NEW GR-8 (32 1/4").

** IN ORDER TO GET SPLICES AS PER THE NEW GR-8, A POST IS TO BE ADDED AT 6'-3" AFTER THE EXISTING GR-8.

TRANSITION FROM WEAK POST (EXISTING GR-8 30"-31" HEIGHT) TO CURRENT NCHRP 350 TL-3 WEAK POST (STANDARD GR-8 32 1/4" HEIGHT)

VDOT

ROAD AND BRIDGE STANDARDS

SHEET 7 OF 8

REVISION DATE

501.40

W-BEAM GUARDRAIL INSTALLATION CRITERIA

VIRGINIA DEPARTMENT OF TRANSPORTATION

SPECIFICATION REFERENCE

221
505

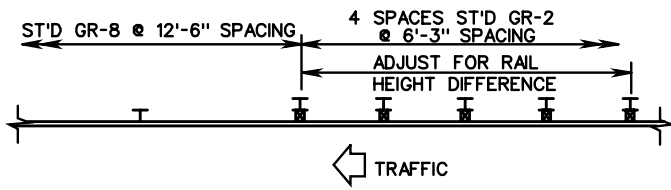

TRANSITION FROM STRONG POST TO WEAK POST GUARDRAIL

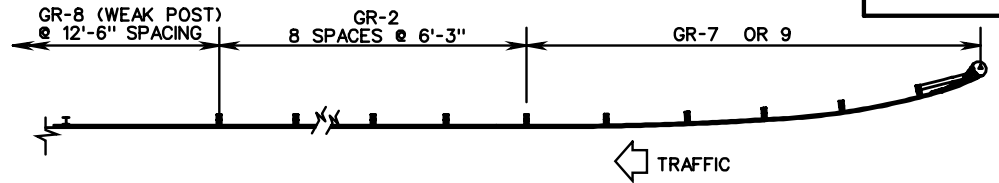

TRANSITION FROM GR-7 & GR-9 TERMINAL TO WEAK POST GUARDRAIL

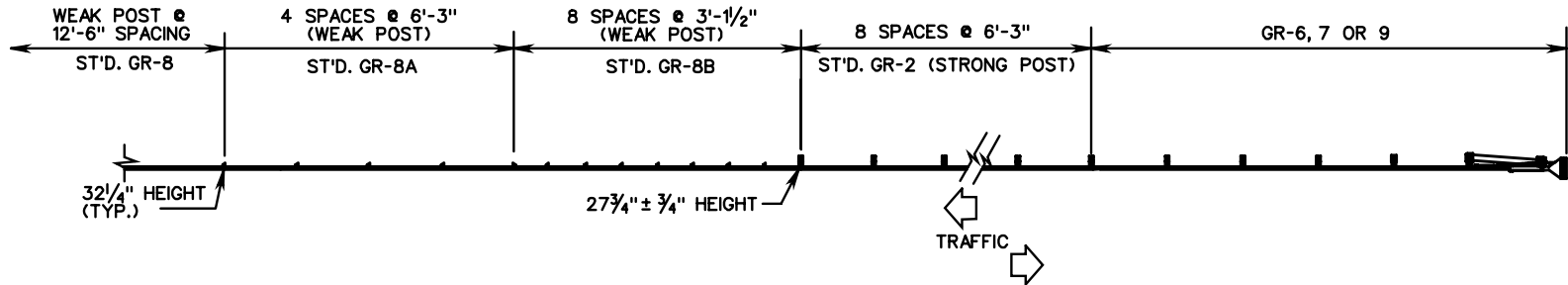

TRANSITION FROM GR-6, GR-7, OR GR-9 TERMINAL TO WEAK POST GUARDRAIL

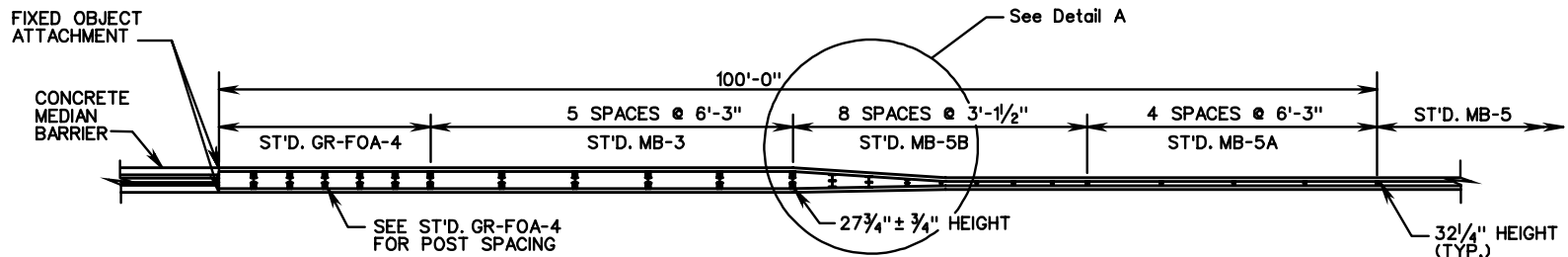

TRANSITION FROM WEAK POST MEDIAN BARRIER TO CONCRETE MEDIAN BARRIER

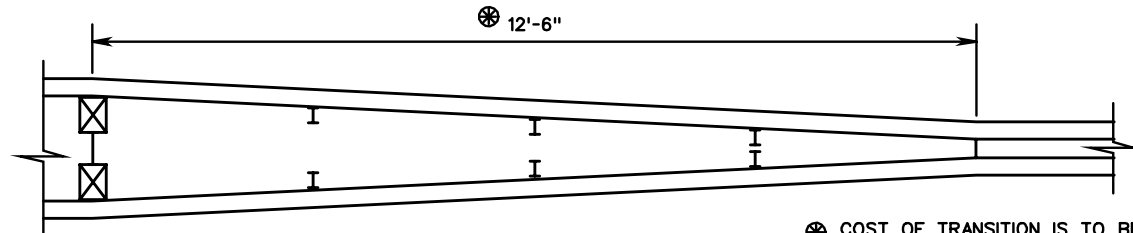

DETAIL A

⊛ COST OF TRANSITION IS TO BE INCLUDED IN PRICE BID FOR ST'D. MB-5B MEDIAN BARRIER.

SPECIFICATION REFERENCE

221
505

W-BEAM GUARDRAIL AND MEDIAN BARRIER INSTALLATION CRITERIA

VIRGINIA DEPARTMENT OF TRANSPORTATION

VDOT

ROAD AND BRIDGE STANDARDS

REVISION DATE

SHEET 8 OF 8

501.41

MB-3

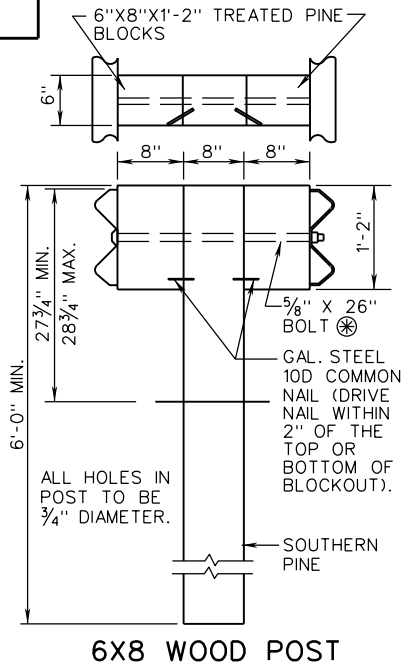

6X8 WOOD POST

POST MAY BE HOT ROLLED OR WELDED

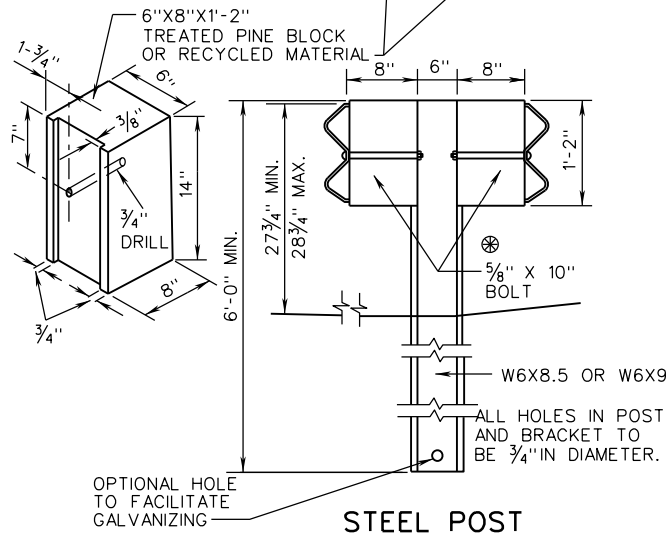

STEEL POST

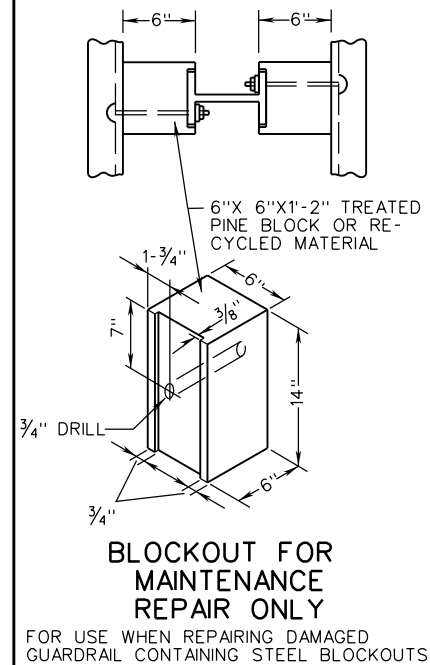

NOTES:

STANDARD MB-3 POST SPACING IS 6'-3".

FOR DETAILS OF RAIL ELEMENT, RAIL SPLICE JOINT, W BEAM BACK UP PLATE, AND ASSOCIATED HARDWARE SEE SHEET NO. 501.01.

ALTERNATE TYPE POSTS AND BLOCKOUTS MAY BE INTERCHANGED ON ANY ONE PROJECT WITH THE RESTRICTION THAT THE SAME TYPE OF POST AND BLOCKOUT MUST BE USED IN ANY SINGLE RUN OF MEDIAN BARRIER.

ALL BOLTS, NUTS, WASHERS, STEEL POSTS, BENT PLATE POST, AND BLOCKOUTS ARE TO BE GALVANIZED.

⊗ STANDARD WASHERS ARE TO BE USED ON LAST 50' OF RUN OFF END ONLY.

DESIGN SPEED	FLARE RATES		
	INSIDE SHY LINE	BEYOND SHY LINE	
MPH	SHY LINE LS	FLARE RATE	FLARE RATE
70	9'	30:1	15:1 *
60	8'	26:1	14:1 *
50	6.5'	21:1	11:1 *
40	5'	16:1	8:1 *
30	4'	13:1	7:1 *

* SUGGESTED MAXIMUM FLARE RATE FOR SEMI-RIGID BARRIER SYSTEMS.

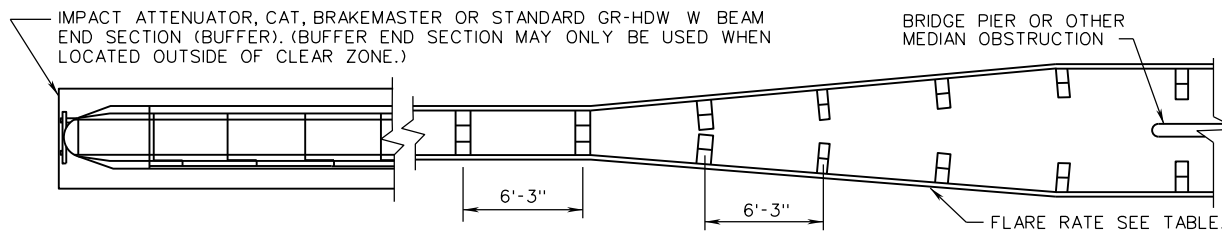

METHOD OF TREATMENT AT BRIDGE PIER OR MEDIAN OBSTRUCTION

A COPY OF THE ORIGINAL SEALED AND SIGNED DRAWING IS ON FILE IN THE CENTRAL OFFICE.

BLOCKED-OUT W-BEAM MEDIAN BARRIER

SPECIFICATION REFERENCE

221
505



ROAD AND BRIDGE STANDARDS

SHEET 1 OF 1

REVISION DATE

502.01

08/14

VIRGINIA DEPARTMENT OF TRANSPORTATION

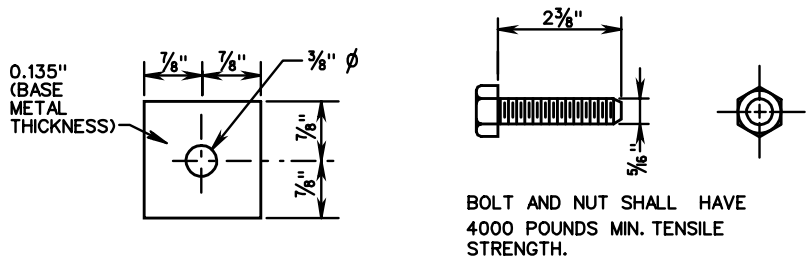

SQUARE WASHER 5/16" HEX BOLT AND NUT

⊗ THE GUARDRAIL AND MEDIAN BARRIER COMPONENTS DEPICTED IN A.R.T.B.A. TECHNICAL BULLETIN NUMBER 268B MAY BE SUBSTITUTED IF INTERCHANGEABLE WITH THE STANDARDS FOR GUARDRAIL (GR) OR MEDIAN BARRIER (MB) AND APPROVED BY THE ENGINEER.

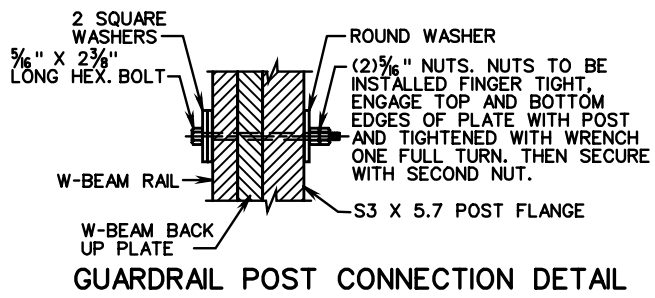

GUARDRAIL POST CONNECTION DETAIL

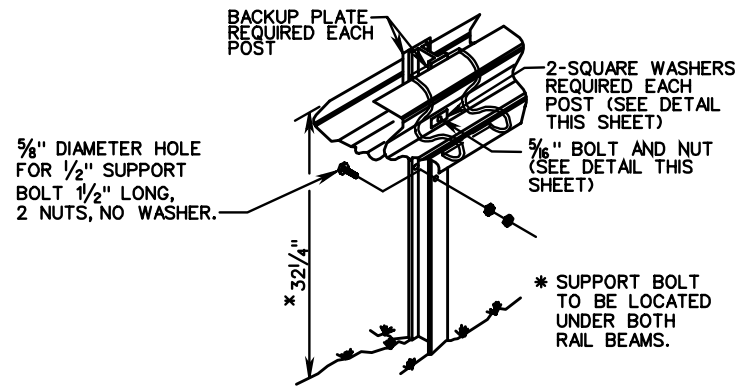

TYPICAL INSTALLATION

* HEIGHT TOLERANCE ± 3/4"

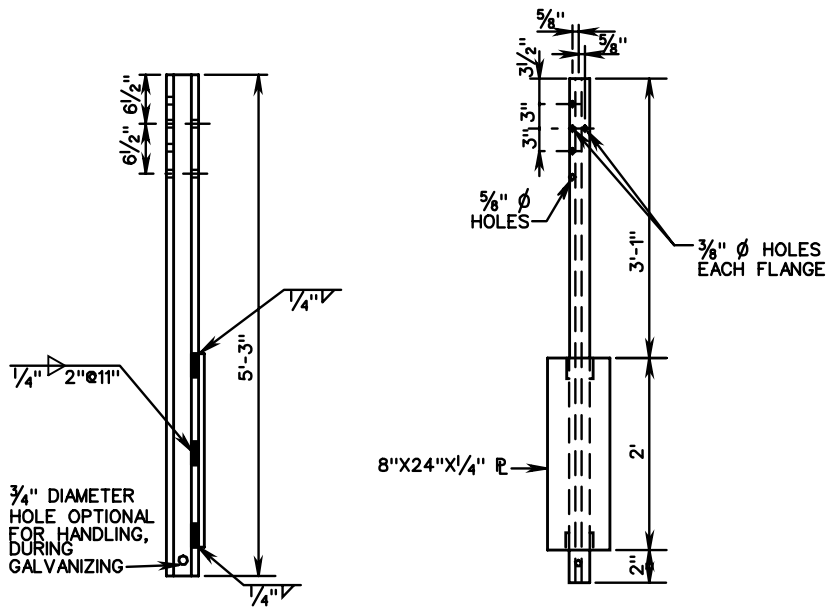

FOR ROCK INSTALLATION, 8" X 26" X 1/4" PLATE IS TO BE ELIMINATED. DRILL OR EXCAVATE HOLE FOR POST, PLACE AND BACKFILL WITH CRUSHER RUN AGGREGATE TO LEVEL OF ROCK.

S3X5.7 STEEL POST

NOTES:
 STANDARD MB-5 POST SPACING IS 12'-6"
 STANDARD MB-5A POST SPACING IS 6'-3"
 STANDARD MB-5B POST SPACING IS 3'-1/2"
 STANDARD MB-5 DEFLECTION IS 7'-0"
 ALL POSTS, BOLTS, NUTS AND WASHERS ARE TO BE GALVANIZED.
 FOR DETAILS OF GUARDRAIL ELEMENT, HARDWARE, ETC. SEE SHEET NO. 501.01.
 FOR DETAILS OF GUARDRAIL SPLICE JOINT, SEE STD. GR-8 DEPICTING AN NCHRP 350 TL-3 INSTALLATION.

SPECIFICATION REFERENCE	STANDARD W-BEAM MEDIAN BARRIER (WEAK POST SYSTEM) TL-3 (>45 MPH) VIRGINIA DEPARTMENT OF TRANSPORTATION		VDOT ROAD AND BRIDGE STANDARDS	
			REVISION DATE	SHEET 1 OF 2
221 505			502.02	

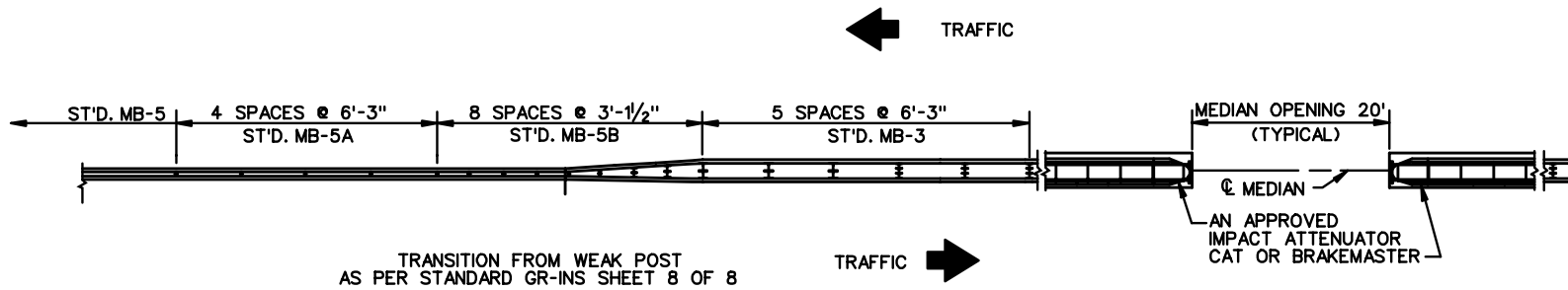

TREATMENT FOR MEDIAN BARRIER CROSS-OVER



ROAD AND BRIDGE STANDARDS

SHEET 2 OF 2

REVISION DATE

502.03

STANDARD W-BEAM MEDIAN BARRIER
(WEAK POST SYSTEM)

VIRGINIA DEPARTMENT OF TRANSPORTATION

SPECIFICATION
REFERENCE

221
505

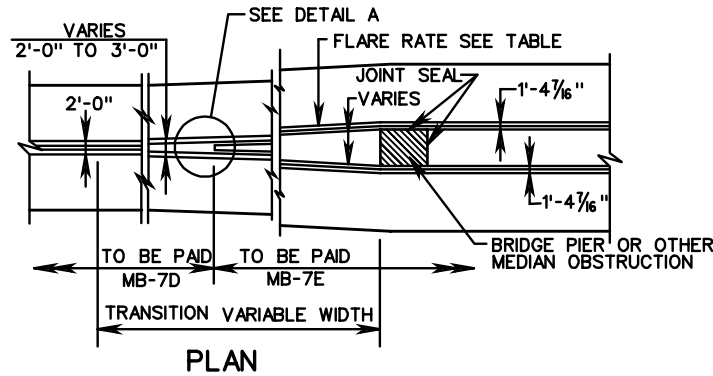

* SUGGESTED MAXIMUM FLARE RATE FOR RIGID BARRIER SYSTEMS.

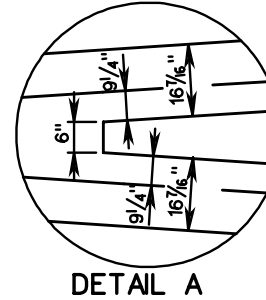

DESIGN SPEED	FLARE RATES		
	INSIDE SHY LINE	BEYOND SHY LINE	
MPH	SHY LINE LS	FLARE RATE	FLARE RATE
70	10'	30:1	20:1 *
60	8'	26:1	18:1 *
50	6.5'	21:1	14:1 *
40	5'	16:1	10:1 *
30	3.5'	13:1	8:1 *

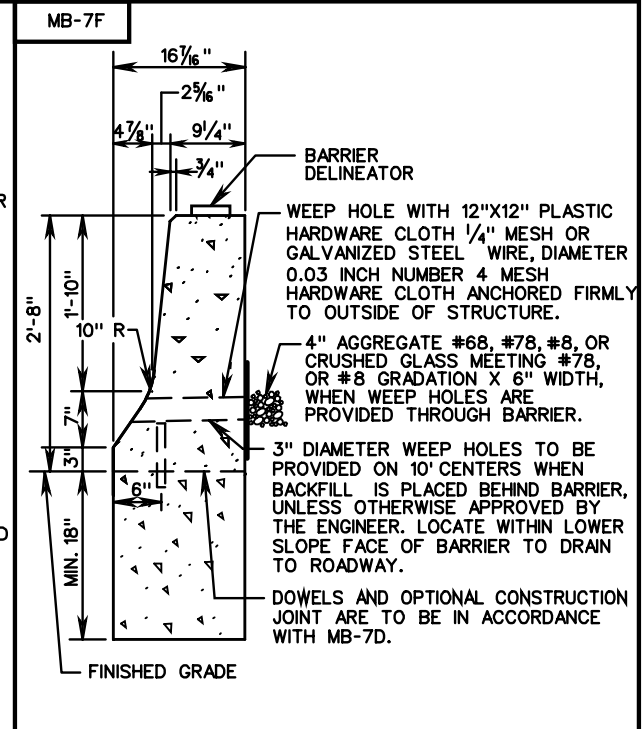
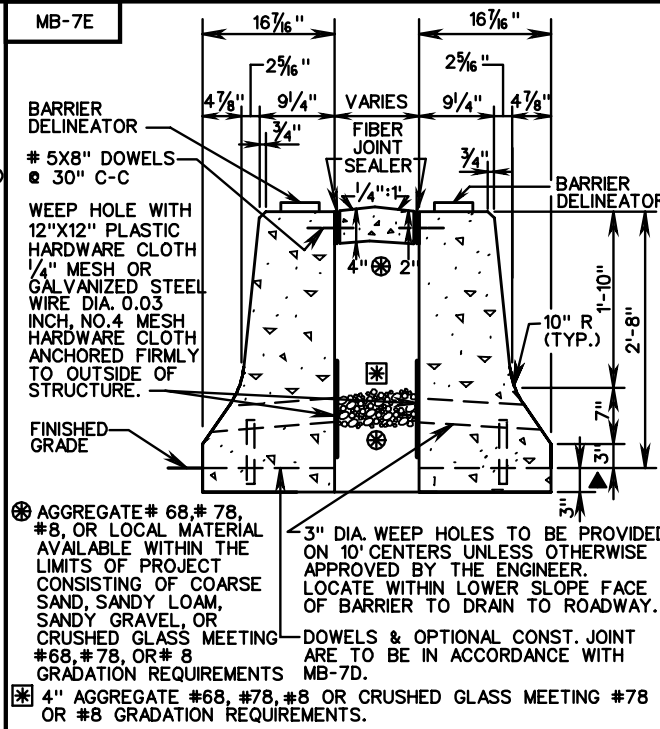
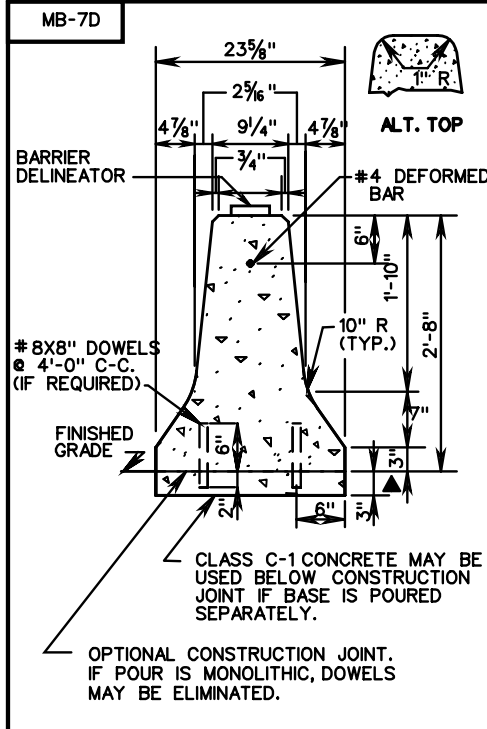

NOTES:
 IF THE CONTRACTOR ELECTS TO USE THE OPTIONAL CONSTRUCTION JOINT, TRANSVERSE JOINTS FOR CRACK CONTROL AND EXPANSION JOINTS ARE TO BE PROVIDED IN BOTH FOOTING AND BARRIER AT THE SAME LOCATION.
 TRANSVERSE JOINTS ARE TO COINCIDE WITH JOINTS IN ADJACENT PAVEMENT WITH A MAXIMUM SPACING OF 20 FEET C-C.
 CONCRETE MEDIAN BARRIER MAY BE PRECAST, CAST IN PLACE OR SLIP-FORMED. FOR PRECAST DESIGN SEE STANDARD MB-7D PC.
 HORIZONTAL REINFORCING STEEL BARS ARE TO BE SEPARATED AT ALL EXPANSION AND CONTRACTION JOINTS. A 2" CONCRETE COVER IS REQUIRED OVER THE ENDS OF THE REINFORCING STEEL.

BARRIER DELINEATOR SIZE, COLOR, AND SPACING TO BE IN ACCORDANCE WITH THE SPECIFICATIONS.
 COST OF DELINEATOR TO BE INCLUDED IN THE PRICE BID FOR MEDIAN BARRIER. REFLECTIVE SURFACE OF BARRIER DELINEATOR IN ALL INSTANCES, TO BE FACING ONCOMING TRAFFIC.
 ALTERNATE TOP DESIGN SHOWN ON MB-7D. MAY ALSO BE APPLIED TO MB-7E AND MB-7F. CONCRETE TO BE CLASS A3 IF CAST IN PLACE, 4000 PSI IF PRECAST.
 ▲ DEPTH OF CONCRETE BASE MAY BE EXTENDED AT THE CONTRACTOR'S OPTION TO COINCIDE WITH BOTTOM OF PAVEMENT COURSE IN WHICH BASE TERMINATES; HOWEVER, THE COST OF ADDITIONAL CONCRETE SHALL BE INCLUDED IN UNIT PRICE BID PER LINEAR FOOT OF BARRIER.

SPECIFICATION REFERENCE
105 502

CONCRETE MEDIAN BARRIER

VIRGINIA DEPARTMENT OF TRANSPORTATION

VDOT	
ROAD AND BRIDGE STANDARDS	
REVISION DATE	SHEET 1 OF 1
	502.04

*FOR PROPRIETARY MB-7D LENGTHS, REFER TO MANUFACTURER

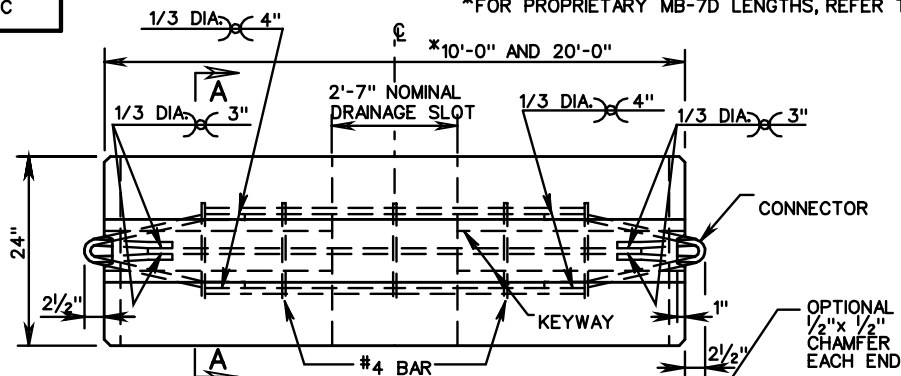

PLAN VIEW

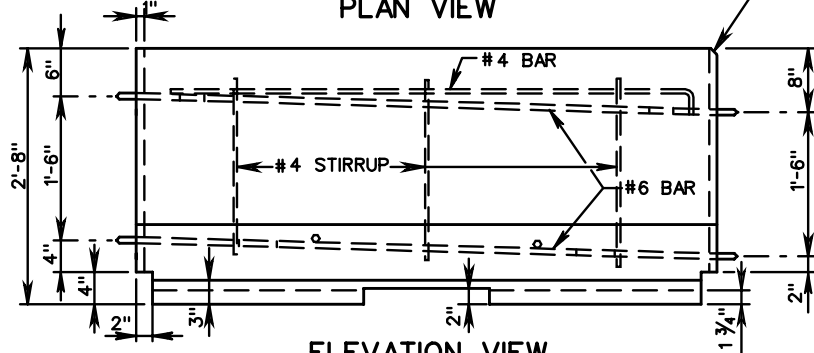

ELEVATION VIEW

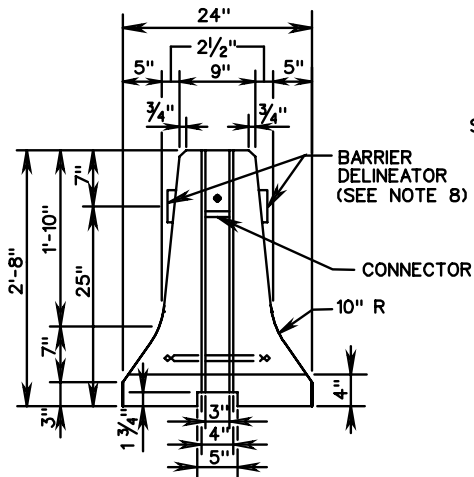

END VIEW

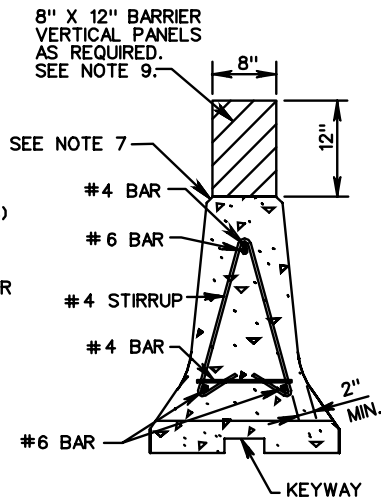

SECTION A-A

NOTES:

1. FOR POSITIVE CONNECTION DETAILS AND DIMENSIONS SEE SHEETS 502.20 - 502.24.
2. AT THE OPTION OF THE MANUFACTURER, ADDITIONAL REINFORCING MAY BE ADDED TO THE PRECAST CONCRETE BARRIER FOR HANDLING.
3. CONCRETE SHALL BE 4000 P.S.I. MINIMUM.
4. BARRIER DELINEATOR SIZE, COLOR AND SPACING SHALL BE IN ACCORDANCE WITH THE SPECIFICATIONS.
5. COST OF DELINEATOR SHALL BE INCLUDED IN THE PRICE BID FOR TRAFFIC BARRIER SERVICE.
6. OTHER PRECAST TRAFFIC BARRIER SERVICE CONCRETE DESIGNS THAT MEET NCHRP 350 TEST REQUIREMENTS AND HAVE BEEN ACCEPTED BY VDOT AS AN ACCEPTABLE ALTERNATE TO THE STANDARD DESIGN MAY BE SUBSTITUTED.
7. A 1" RADIUS MAY BE USED AS AN ALTERNATE FOR THE 3/4" CHAMFER.
8. BARRIER DELINEATOR REFLECTIVE SURFACE IN ALL INSTANCES SHALL BE FACING ONCOMING TRAFFIC.
9. BARRIER VERTICAL PANELS SHALL BE SPACED IN ACCORDANCE WITH VIRGINIA WORK AREA PROTECTION MANUAL.

WHEN USING VDOT STANDARD MB-7D PC WITH THE PIN AND LOOP POSITIVE CONNECTION, ALLOW FOR A 6'-0" DYNAMIC DEFLECTION. PROVIDE MIN. 60' OF BARRIER UPSTREAM AND DOWNSTREAM OF WORK ZONE FOR ANCHORAGE. FOR APPROVED NON-VDOT DESIGNS, REFER TO MANUFACTURER'S INSTALLATION INSTRUCTIONS FOR DEFLECTIONS AND ANCHORAGE.

* FLARE RATES

DESIGN SPEED	INSIDE SHY LINE		BEYOND SHY LINE
	SHY LINE LS	FLARE RATE	FLARE RATE
70	10'	30:1	20:1
60	8'	26:1	18:1
50	6.5'	21:1	14:1
40	5'	16:1	10:1
30	3.5	13:1	8:1

* SUGGESTED MAXIMUM FLARED RATE FOR RIGID BARRIER SYSTEMS.



ROAD AND BRIDGE STANDARDS

SHEET 1 OF 2

REVISION DATE

502.05

PRECAST TRAFFIC BARRIER SERVICE CONCRETE

VIRGINIA DEPARTMENT OF TRANSPORTATION

SPECIFICATION REFERENCE

105
512

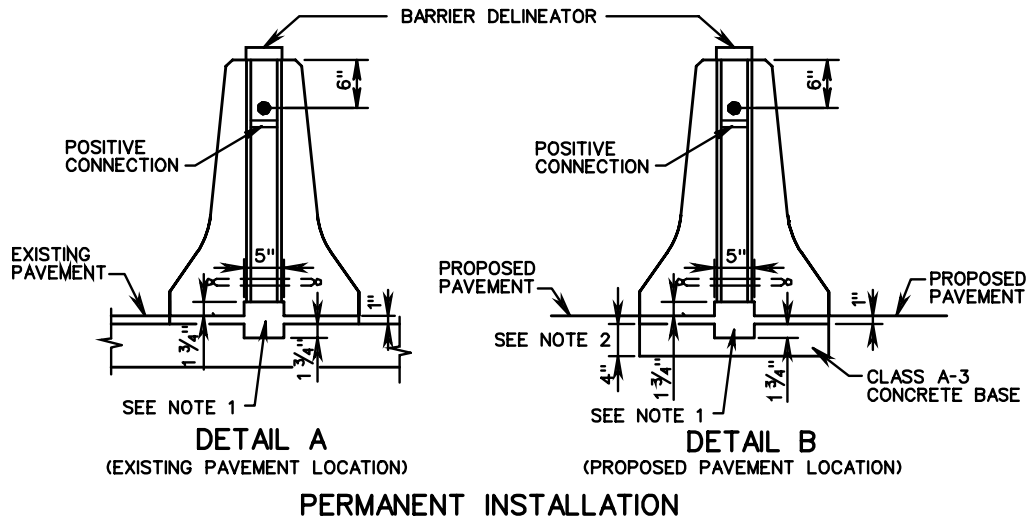

NOTES:

1. HIGH STRENGTH GROUT OR MORTAR SHALL BE IN ACCORDANCE WITH SECTION 218 OF THE SPECIFICATIONS.
2. 4" MIN. OR VARIABLE TO COINCIDE WITH SUBGRADE COURSE.
3. WHEN USED AS MEDIAN BARRIER IN A PERMANENT LOCATION, DRAINAGE SLOTS WILL BE COMPLETELY FILLED AND SEALED WITH MORTAR OR GROUT UNLESS UNIT WILL BE LOCATED OVER MEDIAN DRAINAGE STRUCTURE.
4. BARRIER DELINEATOR SIZE, COLOR, AND SPACING SHALL BE IN ACCORDANCE WITH THE SPECIFICATIONS.
5. COST OF DELINEATOR TO BE INCLUDED IN THE PRICE BID FOR MEDIAN BARRIER.
6. REFLECTIVE SURFACE OF BARRIER DELINEATOR IN ALL INSTANCES SHALL BE FACING ONCOMING TRAFFIC.
7. PIN AND CONNECTORS SHALL BE ASTM-A36. REINFORCING STEEL BARS SHALL BE ASTM A 615 GRADE 60. ONE CONNECTOR PIN ASSEMBLY WITH EACH BARRIER SECTION.

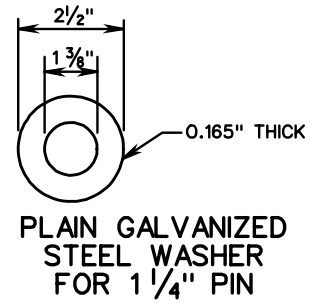
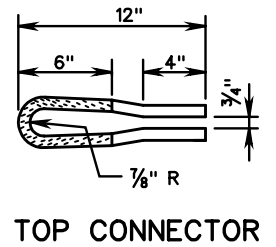
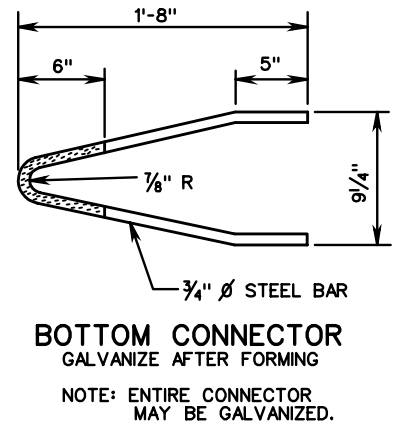
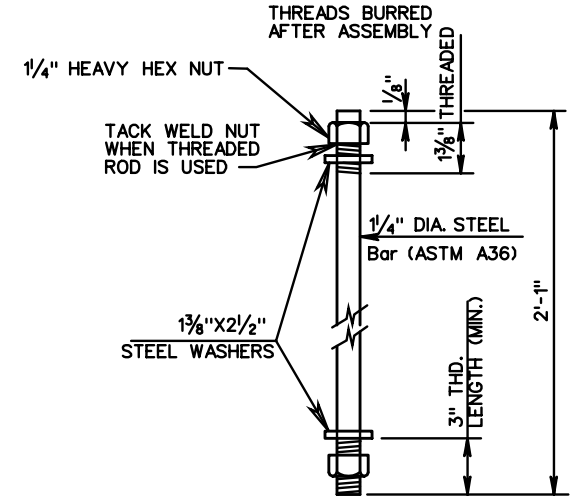
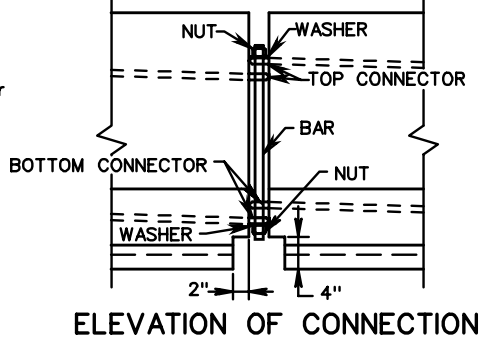
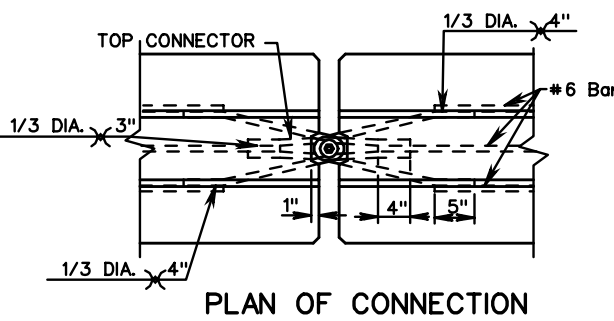

SPECIFICATION REFERENCE
105 512

PRECAST TRAFFIC BARRIER SERVICE CONCRETE

VIRGINIA DEPARTMENT OF TRANSPORTATION

VDOT	
ROAD AND BRIDGE STANDARDS	
REVISION DATE	SHEET 2 OF 2
502.06	

MB-8A

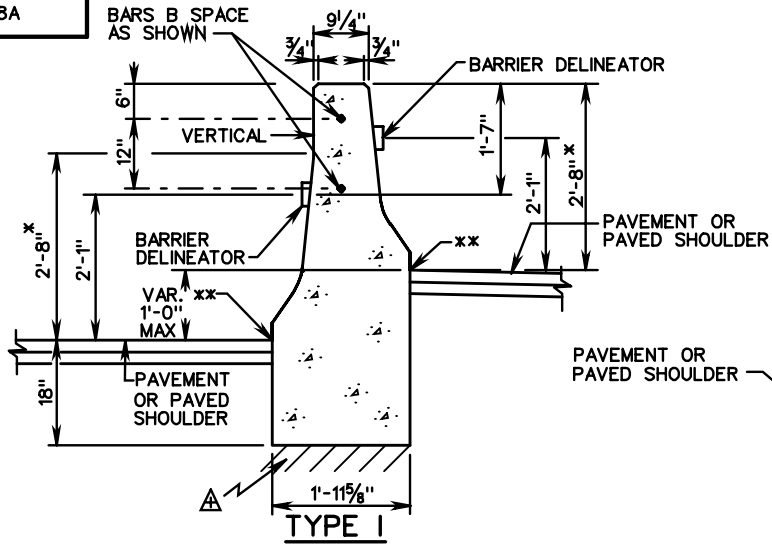

TYPE I (GREATER THAN 0 HT. DIFF., MAX. 1'-0")

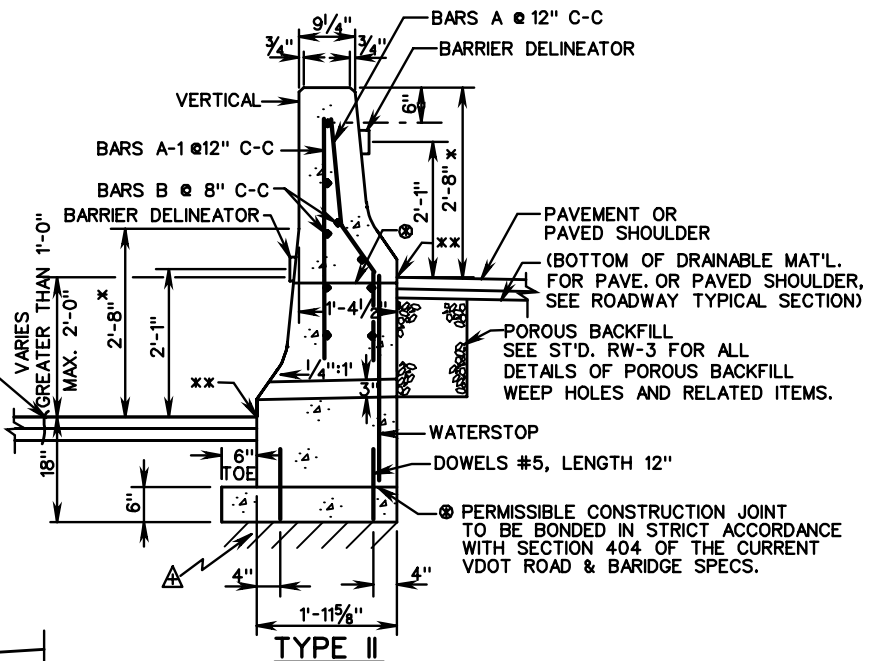

TYPE II (GREATER THAN 1'-0" HT. DIFF., MAX. 2'-0")

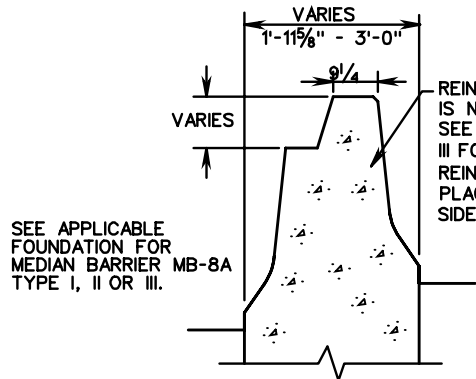
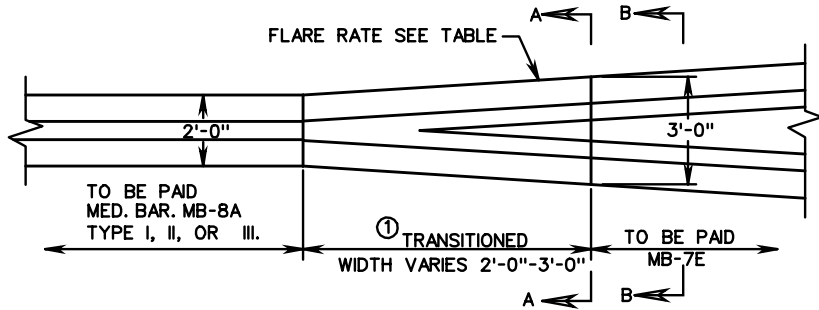

SECTION A-A
(FOUNDATION NOT SHOWN)

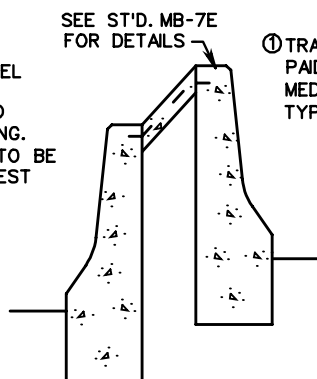

SECTION B-B
(STD. MB-7E)

① TRANSITIONED TO BE PAID FOR AS MED. BARRIER MB-8A TYPE I, II OR III.

* MB-7D BARRIER FACE

** DENOTES FINISHED GRADE ELEVATION

△ FOUNDATION MATERIAL UNDER MEDIAN BARRIER IS TO BE COMPACTED.

FLARE RATES

DESIGN SPEED	INSIDE SHY LINE		BYOND SHY LINE
	SHY LINE LS	FLARE RATE	FLARE RATE
70	10'	30 : 1	20 : 1 ②
60	8'	26 : 1	18 : 1 ②
50	6.5'	21 : 1	14 : 1 ②
40	5'	16 : 1	10 : 1 ②
30	3.5'	13 : 1	8 : 1 ②

② MAXIMUM FLARE RATE FOR RIGID BARRIER SYSTEMS.



ROAD AND BRIDGE STANDARDS

SHEET 1 OF 2

REVISION DATE

502.07

CONCRETE MEDIAN BARRIER

TYPE I, II OR III

VIRGINIA DEPARTMENT OF TRANSPORTATION

SPECIFICATION REFERENCE

105
404
502

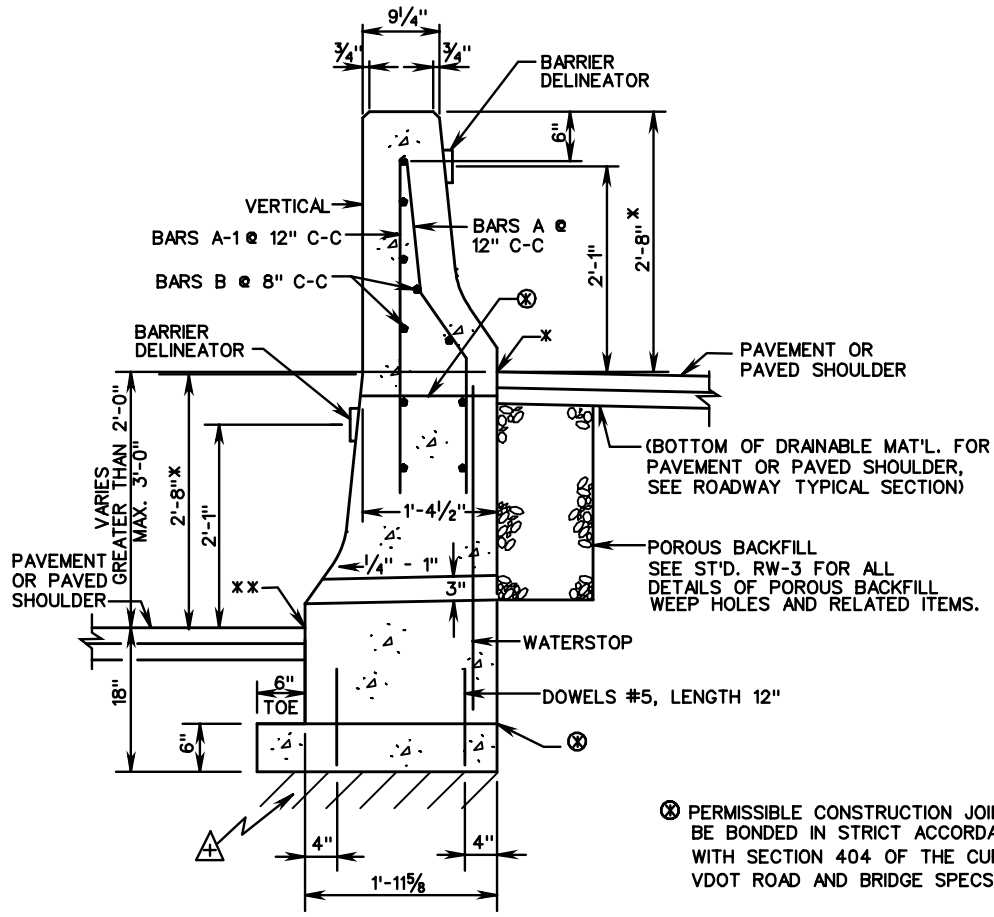

TYPE III

TYPE III (GREATER THAN 2'-0" HT. DIFF., MAX. 3'-0")

MEASUREMENT AND PAYMENT

MEDIAN BARRIER MB-8A TYPE I, II OR III WILL BE PAID FOR AT THE CONTRACT UNIT PRICE PER LIN. FOOT, WHICH SHALL BE FULL COMPENSATION FOR FURNISHING AND INSTALLING CLASS A3 CONCRETE, REINFORCING STEEL, POROUS BACKFILL AND ALL TOOLS, LABOR, EQUIPMENT AND INCIDENTALS NECESSARY TO COMPLETE THE WORK. ANY ADDITIONAL EXCAVATION, BACKFILL WITH SUITABLE MATERIAL AND COMPACTION WORK NECESSARY FOR THE CONCRETE MEDIAN BARRIER INSTALLATION IS TO BE CONSIDERED INCIDENTAL IN THE PRICE BID FOR THE CONCRETE MEDIAN BARRIER.

NOTE:

REINFORCING STEEL BARS SHOWN ARE BASED ON A 20' PANEL LENGTH.
 ALL REINFORCING BARS ARE TO BE SIZE #4 GRADE 60 STEEL WITH A MINIMUM 1/2" CONCRETE COVER.

THE TYPICAL JOINT SPACING FOR CONSTRUCTION JOINTS IS 20' AND 80' FOR EXPANSION JOINTS FOR TYPE II AND III BARRIERS.

FOR DETAILS OF HOW JOINTS ARE TO BE FORMED & WATER STOP DETAILS SEE ST'D. RW-3.

TRANSVERSE JOINTS FOR TYPE I BARRIERS SHALL BE CONSTRUCTED IN ACCORDANCE WITH THE ROAD AND BRIDGE SPECIFICATIONS EXCEPT NO SCORING OR SAWING WILL BE ALLOWED.

HORIZONTAL REINFORCING STEEL BARS B ARE TO BE SEPARATED AT ALL EXPANSION & CONTRACTION JOINTS. A 2" CONCRETE COVER IS REQUIRED OVER THE ENDS OF REINFORCING STEEL.

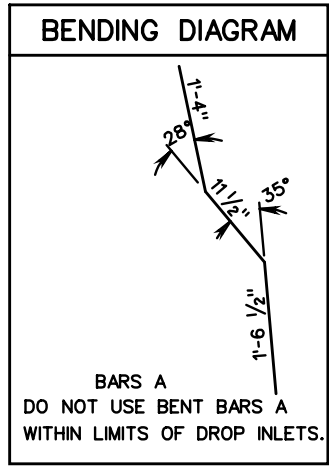

- * MB-7D BARRIER FACE
- ** DENOTES FINISHED GRADE ELEVATION
- △ FOUNDATION MATERIAL UNDER MEDIAN BARRIER IS TO BE COMPACTED.

REINFORCING STEEL SCHEDULE

PANEL	BARS "A"		BARS A-1		BARS "B"		DOWELS	
	NO.	LENGTH	NO.	LENGTH	NO.	LENGTH	NO.	LENGTH
TYPE I					2	19'-8"		
TYPE II	20	4'-0"	20	4'-0"	9	19'-8"	40	1'-0"
TYPE III	20	4'-0"	20	4'-0"	9	19'-8"	40	1'-0"

SPECIFICATION REFERENCE
105
404
502

CONCRETE MEDIAN BARRIER

TYPE I, II OR III

VIRGINIA DEPARTMENT OF TRANSPORTATION



ROAD AND BRIDGE STANDARDS

REVISION DATE	SHEET 2 OF 2
	502.08

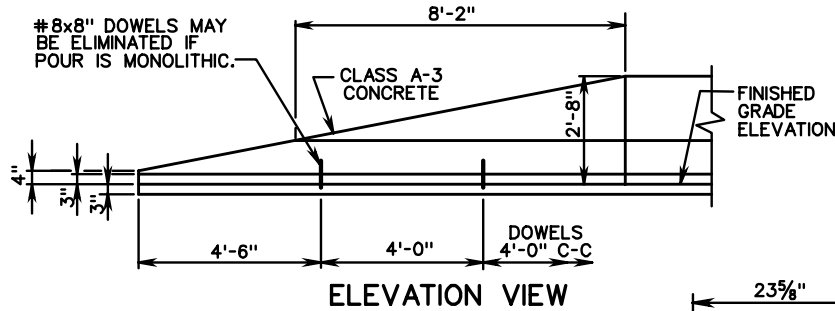
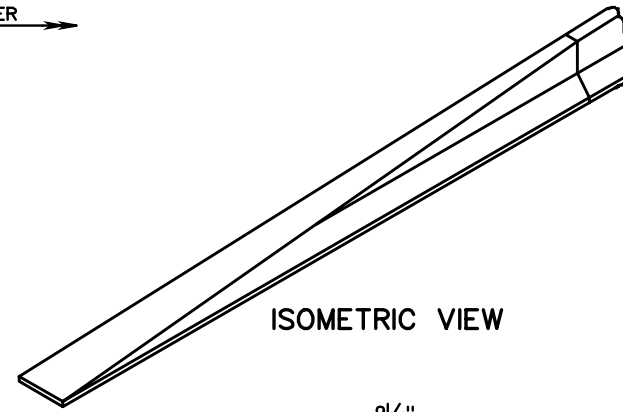
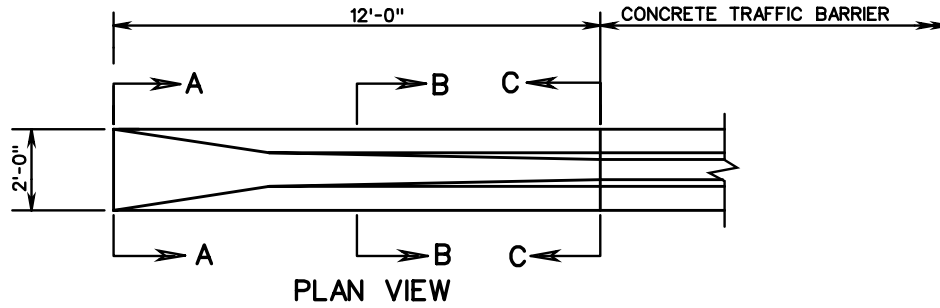

ISOMETRIC VIEW

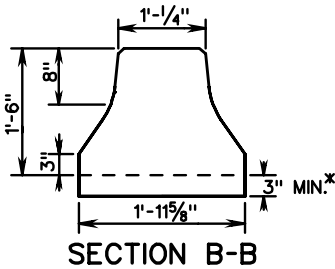
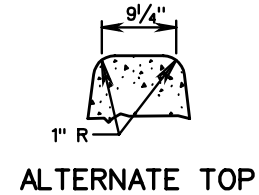

SECTION B-B

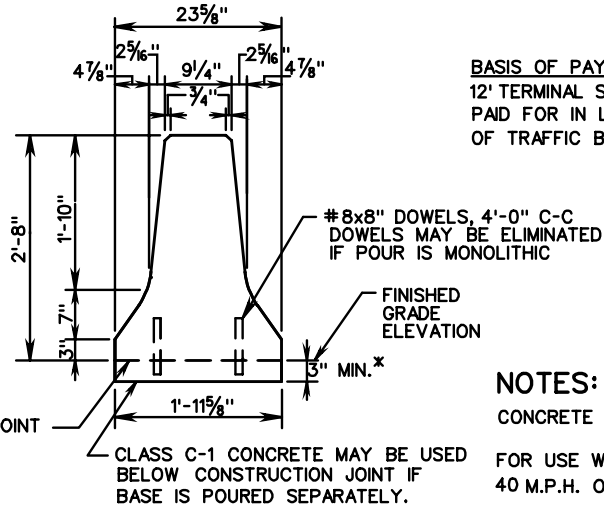

SECTION C-C

BASIS OF PAYMENT: CONCRETE MEDIAN BARRIER
12' TERMINAL SECTION IS TO BE MEASURED AND
PAID FOR IN LIN. FT. ST'D. MB-7D, OR LIN. FT.
OF TRAFFIC BARRIER SERVICE CONCRETE.

NOTES:

CONCRETE TO BE CLASS A3.

FOR USE WHERE THE OPERATING SPEED IS
40 M.P.H. OR LESS.

LOCATION OF THE BARRIER END SECTIONS TO
BE AS NOTED ON PLANS OR AS APPROVED
BY THE ENGINEER.

FOR POSITIVE CONNECTION DETAILS AND
DIMENSIONS SEE STANDARD MB-INS.

ONLY FOR USE OUTSIDE OF CLEAR ZONE.

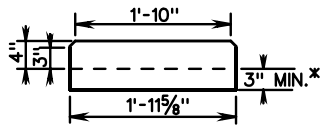

SECTION A-A

* DEPTH OF CONCRETE BASE MAY BE EXTENDED
AT THE CONTRACTOR'S OPTION TO COINCIDE WITH
BOTTOM OF PAVEMENT COURSE IN WHICH BASE
TERMINATES; HOWEVER, THE COST OF ADDITIONAL
CONCRETE SHALL BE INCLUDED IN UNIT PRICE
BID PER LIN. FT. OF BARRIER.

OPTIONAL CONSTRUCTION JOINT

CLASS C-1 CONCRETE MAY BE USED
BELOW CONSTRUCTION JOINT IF
BASE IS POURED SEPARATELY.



ROAD AND BRIDGE STANDARDS

SHEET 1 OF 1

REVISION DATE

502.09

CAST IN PLACE CONCRETE MEDIAN BARRIER
12 FT. TERMINAL SECTION

VIRGINIA DEPARTMENT OF TRANSPORTATION

SPECIFICATION
REFERENCE

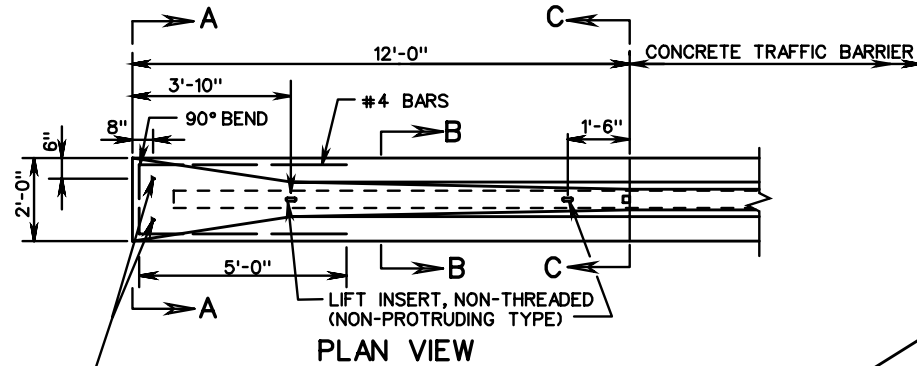

PLAN VIEW

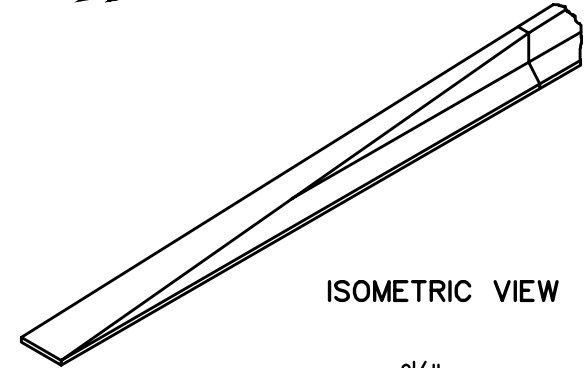

ISOMETRIC VIEW

1" I.D. METAL SLEEVE
(REINFORCING STEEL
SHALL SURROUND
1" I.D. METAL SLEEVE)

USE 3/4" x 9" EXPANSION BOLTS FOR RIGID PAVEMENT
INSTALLATION ONLY (BOLTS TO BE REMOVABLE)

USE 3/4" x 3'-0" DRIFT PINS FOR FLEXIBLE
PAVEMENT INSTALLATIONS.

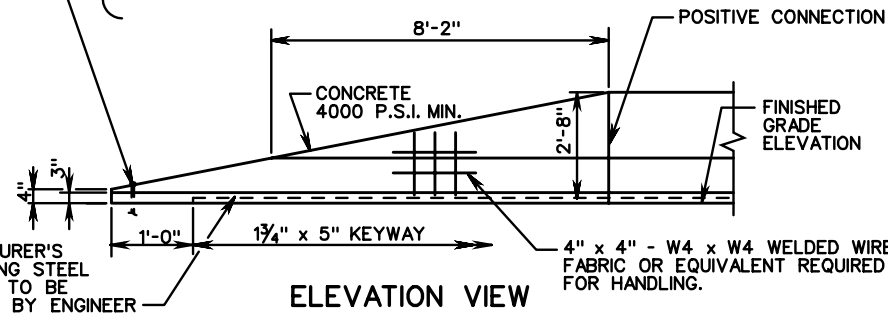

ELEVATION VIEW

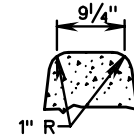

ALTERNATE TOP

BASIS OF PAYMENT: CONCRETE MEDIAN BARRIER
12' TERMINAL SECTION IS TO BE MEASURED AND
PAID FOR IN LIN. FT. ST'D. MB-7D, OR LIN. FT.
OF TRAFFIC BARRIER SERVICE CONCRETE.

MANUFACTURER'S
REINFORCING STEEL
DESIGN IS TO BE
APPROVED BY ENGINEER

4" x 4" - W4 x W4 WELDED WIRE
FABRIC OR EQUIVALENT REQUIRED
FOR HANDLING.

NOTES:

CONCRETE TO BE 4000 P.S.I..

REINFORCING STEEL TO BE GRADE 60.
ALL REINFORCING IS TO HAVE A MINIMUM
CONCRETE COVER OF 1/2".

FOR USE WHERE THE OPERATING SPEED IS
40 M.P.H. OR LESS.

LOCATION OF THE BARRIER END SECTIONS TO
BE AS NOTED ON PLANS OR AS APPROVED
BY THE ENGINEER.

FOR POSITIVE CONNECTION DETAILS AND
DIMENSIONS SEE STANDARD MB-INS.

ONLY FOR USE OUTSIDE OF CLEAR ZONE.

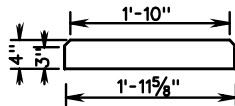

SECTION A-A

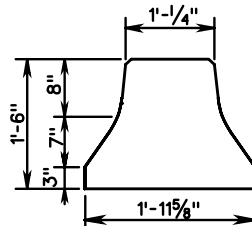

SECTION B-B

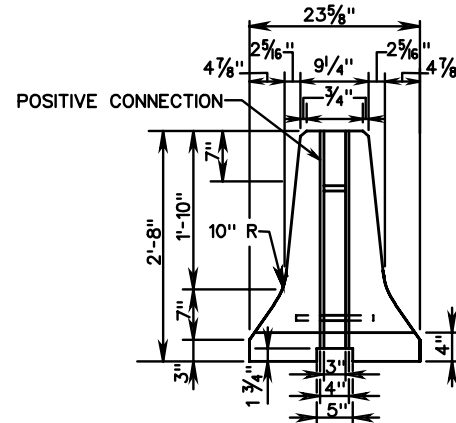

SECTION C-C

SPECIFICATION
REFERENCE

105

PRECAST CONCRETE MEDIAN BARRIER

12 FT. TERMINAL SECTION

VIRGINIA DEPARTMENT OF TRANSPORTATION

VDOT

ROAD AND BRIDGE STANDARDS

REVISION DATE

SHEET 1 OF 1

502.10

MB-10A

A

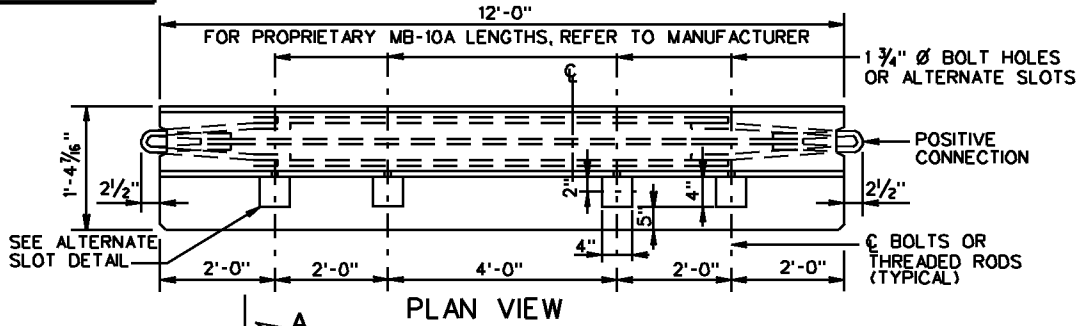

PLAN VIEW

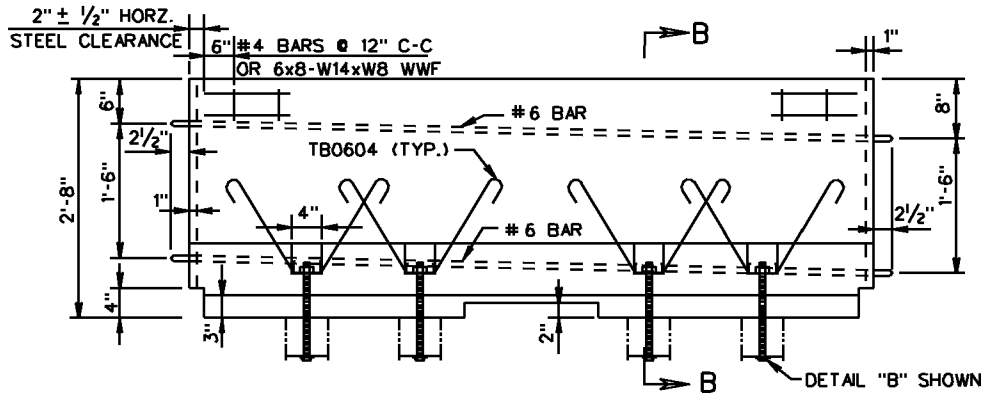

ELEVATION VIEW

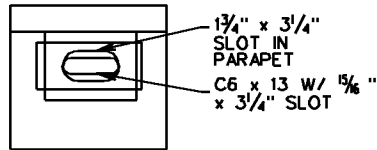

ALTERNATE SLOT DETAIL

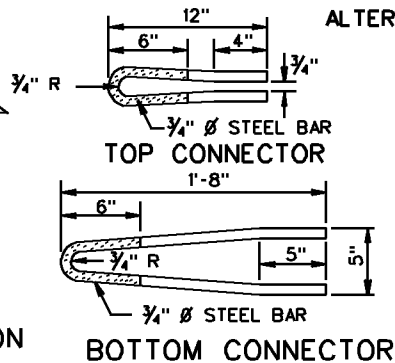
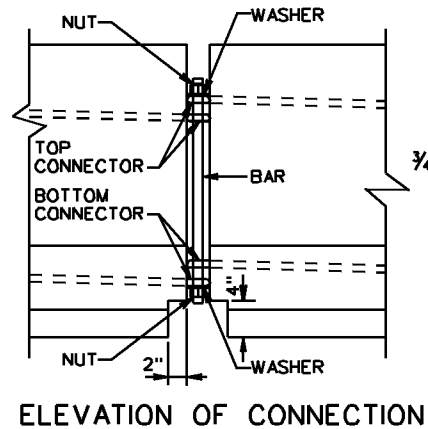

BOTTOM CONNECTOR

GALVANIZE AFTER FORMING
NOTE: ENTIRE CONNECTOR MAY BE GALVANIZED.

ALL ENDS OPTIONAL CHAMFER (1/2" x 1/2")

POSITIVE CONNECTION

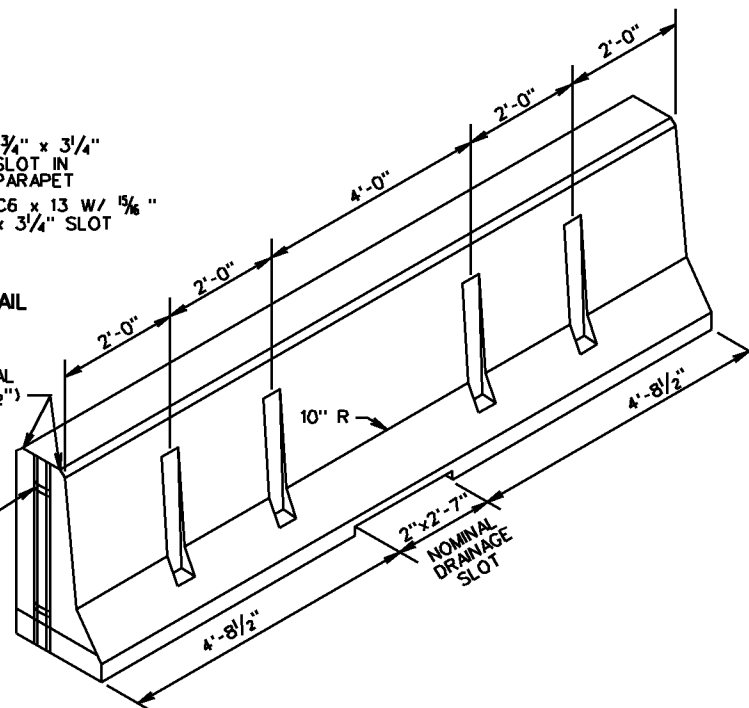

REINFORCING STEEL SCHEDULE

FOR ONE (1) SECTION

MARK	No.	SIZE	LENGTH	PIN Ø	LOCATION
TB0401	8	4	1'-5"	—	TEMP. PARAPET
TB0502	12	5	4'-3"	2 1/2"	"
TB0503	12	5	2'-8"	2 1/2"	"
TB0604	8	6	4'-8"	4 1/2"	"

BENDING DIAGRAM

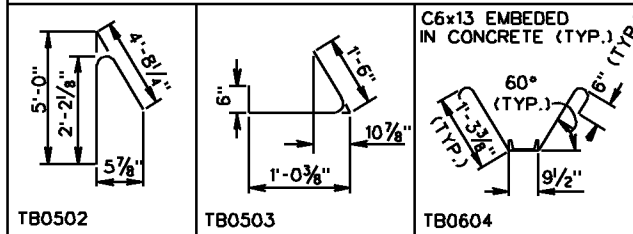

DIMENSIONS IN BENDING DIAGRAMS ARE OUT-TO-OUT OF BARS, EXCEPT AS SHOWN.
POUNDS OF REINFORCING STEEL = 202
REINFORCING SCHEDULE BASED ON 12'-0" UNIT LENGTH.

VDOT

ROAD AND BRIDGE STANDARDS

SHEET 1 OF 2

REVISION DATE

502.11

01/09

TRAFFIC BARRIER SERVICE CONCRETE PARAPET (SINGLE FACE)

(FOR TEMPORARY INSTALLATION ON BRIDGE DECK EXTERIOR)

VIRGINIA DEPARTMENT OF TRANSPORTATION

SPECIFICATION REFERENCE

105
502

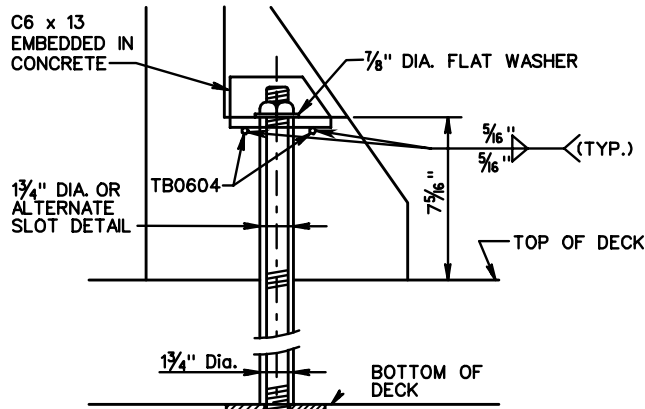

7/8" Ø H.S. BOLT & HEX NUT (A325), OR 7/8" Ø DOUBLE ENDED THREADED ROD & HEX NUT (A-193 GR. B7).

3 1/2" x 3 1/2" x 1/2" SQUARE WASHER (A36 OR A572) WITH 1 5/16" Ø HOLE.

AT THE DISCRETION OF THE ENGINEER, A LARGER WASHER SIZE MAY BE REQUIRED IF SPALLING IS EVIDENT AT BOTTOM OF DECK. TO PREVENT OR MINIMIZE SPALLING, PREDRILLING A PILOT HOLE USING A SMALLER DIAMETER DRILL BIT IS REQUIRED.

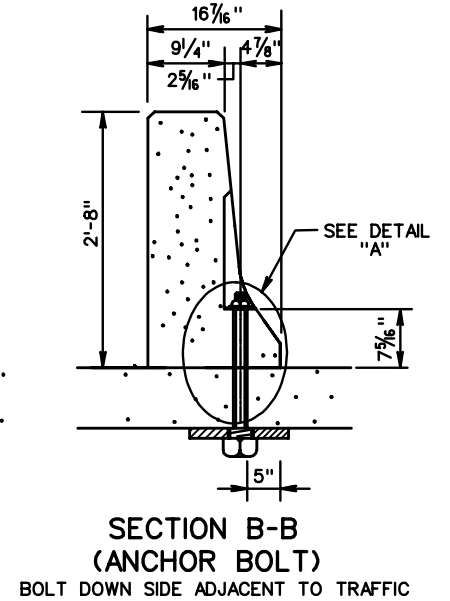
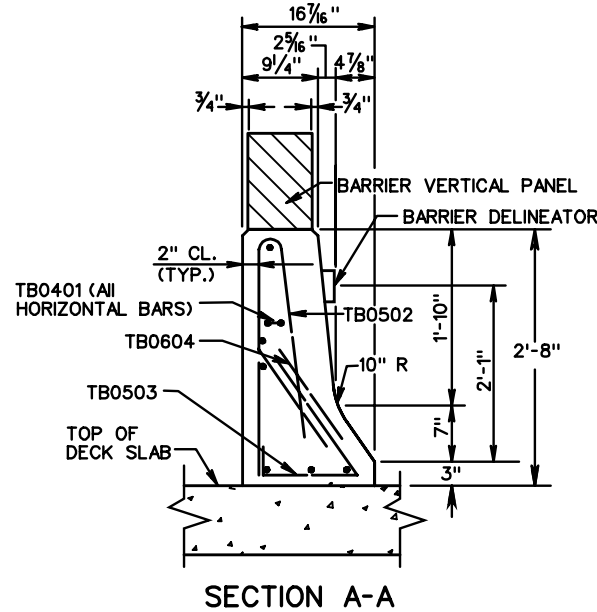

DETAIL "A" NOTES:

1. BARRIER DELINEATOR TO BE SPACED IN ACCORDANCE WITH SECTION 702, OF THE ROAD AND BRIDGE SPECIFICATIONS AND THE BARRIER VERTICAL PANELS TO BE SPACED IN ACCORDANCE WITH VIRGINIA WORK AREA PROTECTION MANUAL. REFLECTIVE SURFACE, IN ALL INSTANCES, TO BE FACING ONCOMING TRAFFIC.
2. CONCRETE 4000 PSI(MIN.). REINFORCING STEEL GRADE 60.
3. AFTER REMOVING TEMPORARY BARRIER, CUT 7/8" Ø BOLT OR THREADED ROD AS LOW AS PRACTICAL BELOW ROADWAY SURFACE AND FILL RECESS WITH EPOXY BONDING COMPOUND EP-4 (DETAIL "A") OR REMOVE 7/8" Ø BOLTS OR THREADED RODS AND FILL HOLES WITH GROUT BONDED WITH EPOXY BONDING COMPOUND EP-4 (DETAIL "A").
4. COST OF BARRIER DELINEATOR AND BARRIER VERTICAL PANELS TO BE INCLUDED IN PRICE BID PER LINEAR FOOT OF BARRIER SERVICE.
5. WHEN BARRIER IS LOCATED ON VERTICAL AND/OR HORIZONTAL CURVES, THE OPENING AT THE JOINT IS NOT TO EXCEED 1".
6. DESIGN FEATURES RELATING TO CONSTRUCTION OR TO REGULATION AND CONTROL OF TRAFFIC MAY BE SUBJECT TO CHANGE AS DEEMED NECESSARY BY THE DEPARTMENT.
7. FOR POSITIVE CONNECTION DETAILS AND DIMENSIONS SEE STANDARD SHEETS 502.20 - 502.24.

SPECIFICATION REFERENCE

TRAFFIC BARRIER SERVICE CONCRETE PARAPET (SINGLE FACE)
(FOR TEMPORARY INSTALLATION ON BRIDGE DECK EXTERIOR)
VIRGINIA DEPARTMENT OF TRANSPORTATION

VDOT

ROAD AND BRIDGE STANDARDS

REVISION DATE

SHEET 2 OF 2

502.12

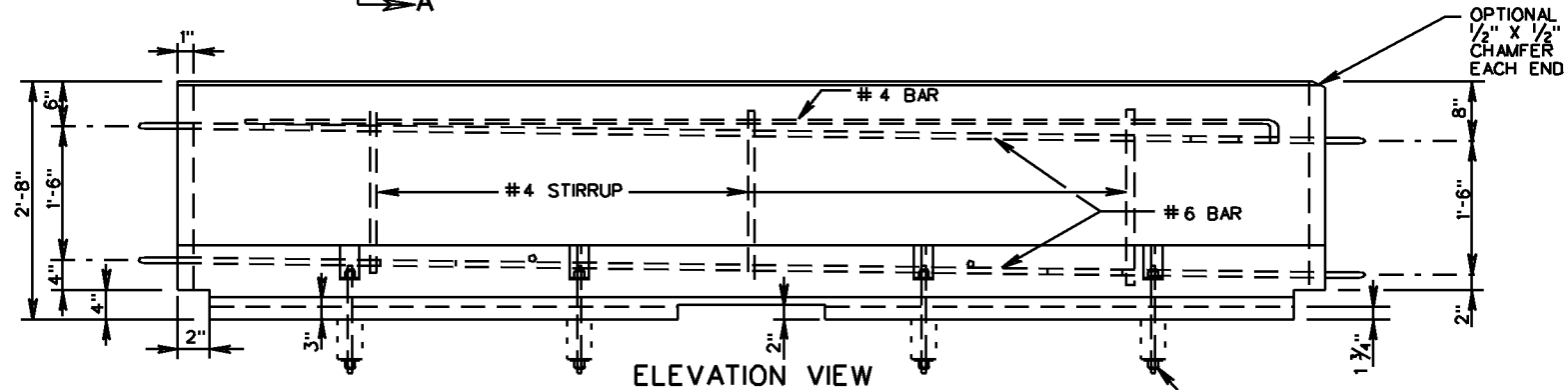
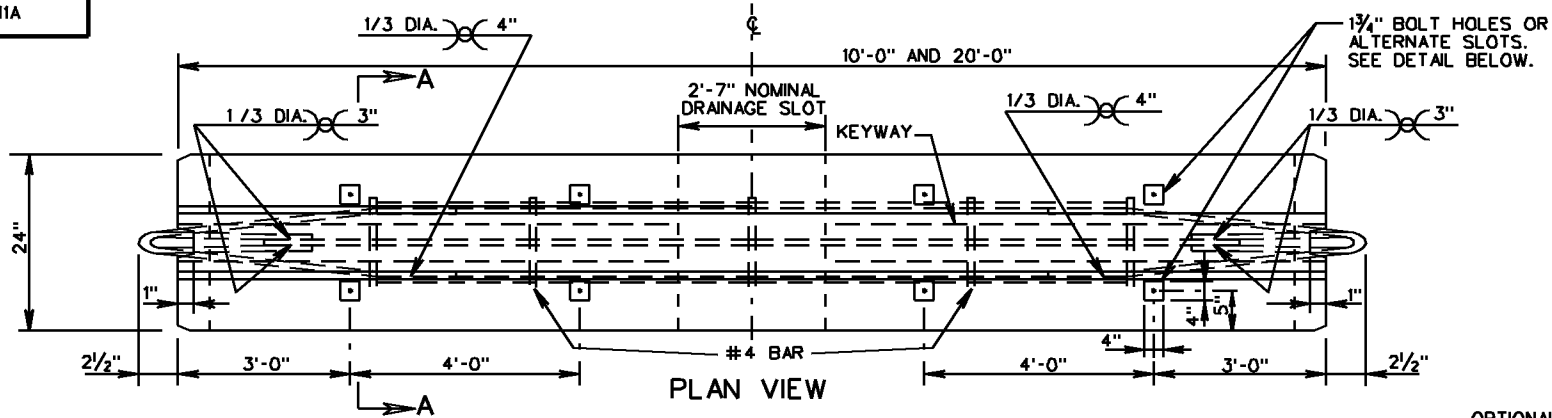

3 1/2" X 3 1/2" X 1/2" SQUARE WASHER. SEE DETAIL B, SHEET 2 OF 2.

8" X 12" BARRIER VERTICAL PANELS AS REQUIRED. SEE NOTE 1.

SEE ALTERNATE TOP DETAIL

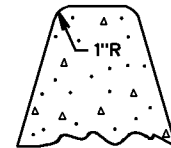
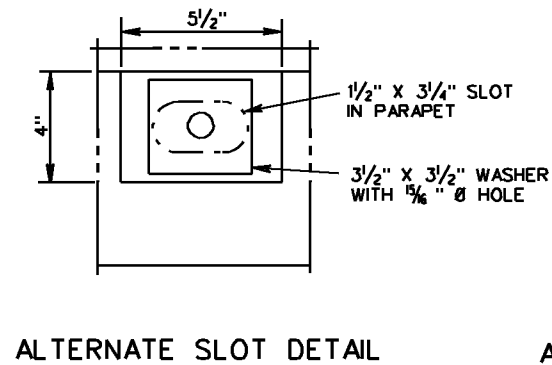
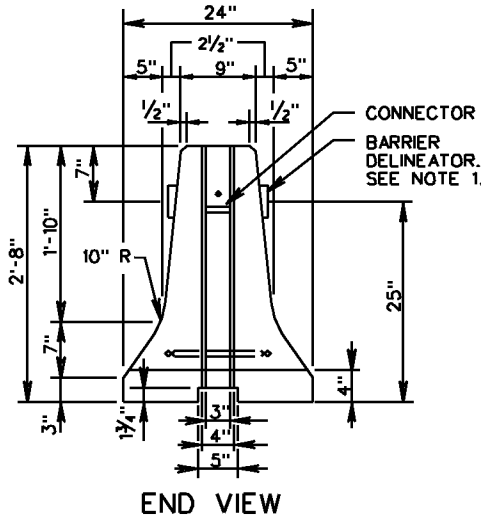
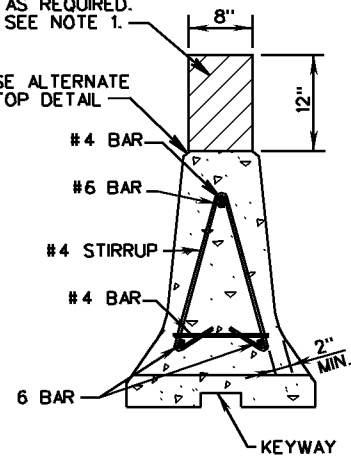

NOTES:

1. BARRIER DELINEATOR IS TO BE SPACED IN ACCORDANCE WITH SECTION 702 OF THE ROAD AND BRIDGE SPECIFICATIONS AND THE BARRIER VERTICAL PANELS ARE TO BE SPACED IN ACCORDANCE WITH THE VIRGINIA WORK AREA PROTECTION MANUAL.
2. REFLECTIVE SURFACE, IN ALL INSTANCES, ARE TO BE FACING ONCOMING TRAFFIC.
3. COST OF BARRIER DELINEATOR AND BARRIER VERTICAL PANELS ARE TO BE INCLUDED IN PRICE BID PER LINEAR FOOT OF BARRIER SERVICE.
4. ANCHOR BOLTS SHALL BE INSTALLED ON TRAFFIC SIDE.
5. CONCRETE 4000 PSI. (MIN.)
6. WELDED WIRE FABRIC MAY BE ONE SHEET BENT TO FIT CONFIGURATION OR TWO SEPARATE SHEETS, ONE ON EACH FACE.
7. AFTER REMOVING TEMPORARY BARRIER, CUT $\frac{7}{8}$ " \emptyset BOLT OR THREADED ROD AS LOW AS PRACTICAL BELOW ROADWAY SURFACE AND FILL RECESS WITH EPOXY BONDING COMPOUND EP-4 (DETAIL "A") OR REMOVE $\frac{7}{8}$ " \emptyset BOLT OR THREADED ROD AND FILL HOLE WITH GROUT BONDED WITH EPOXY BONDING COMPOUND EP-4, (DETAIL "A").
8. FOR POSITIVE CONNECTION DETAILS AND DIMENSIONS SEE STANDARD MB-INS.

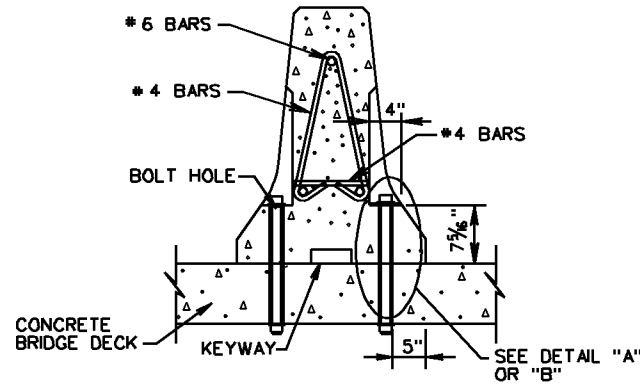

**SECTION B-B
(ANCHOR BOLT)**
BOLT DOWN SIDE ADJACENT TO TRAFFIC

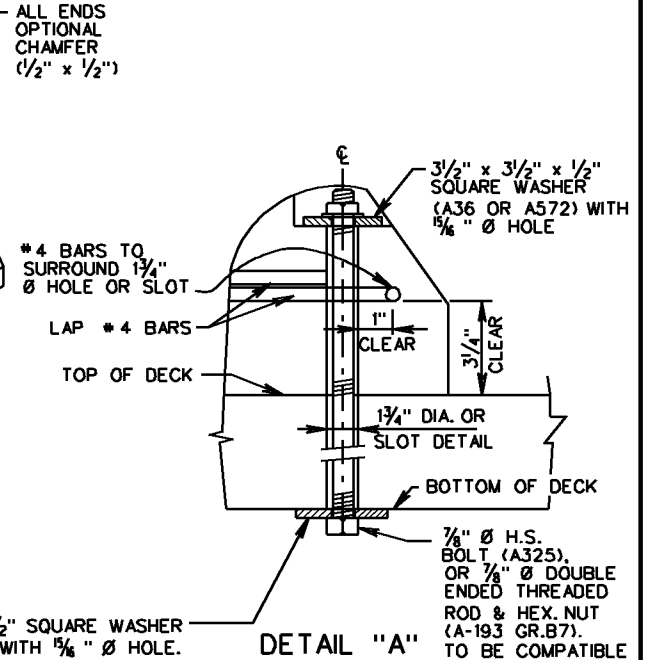
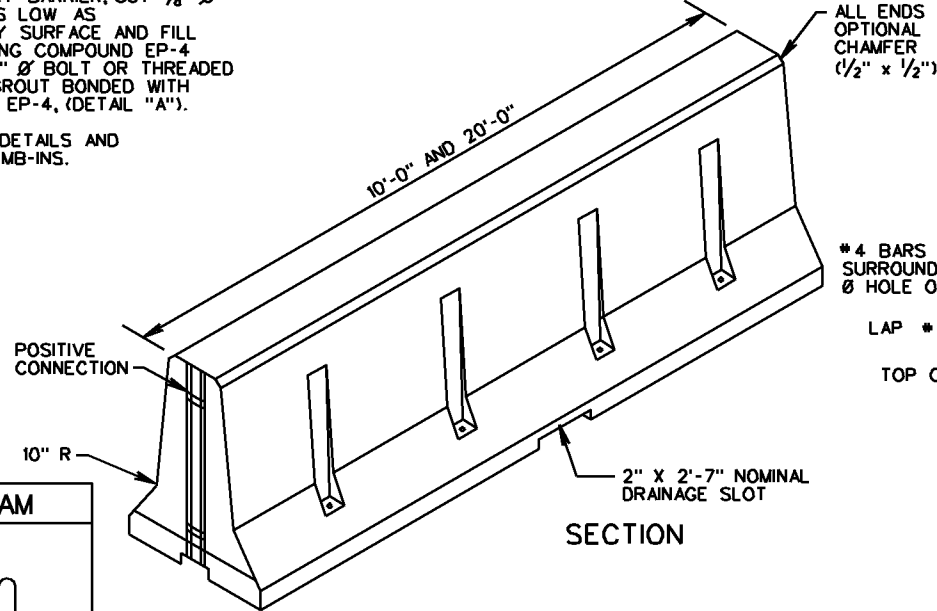

DETAIL "A"
 $\frac{3}{2}$ " x $\frac{3}{2}$ " x $\frac{1}{2}$ " SQUARE WASHER (A36 OR A572) WITH $\frac{5}{16}$ " \emptyset HOLE.
 AT THE DISCRETION OF THE ENGINEER, A LARGER WASHER SIZE MAY BE REQUIRED IF SPALLING IS EVIDENT AT BOTTOM OF DECK. TO PREVENT OR MINIMIZE SPALLING, PREDRILLING A PILOT HOLE USING A SMALLER DIAMETER DRILL BIT IS REQUIRED.

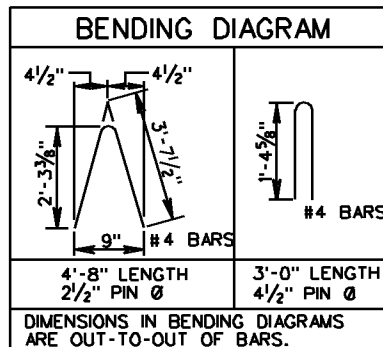

SPECIFICATION REFERENCE
105 512

**TRAFFIC BARRIER SERVICE CONCRETE PARAPET
(DOUBLE FACE)**

(FOR TEMPORARY INSTALLATION ON BRIDGE DECK EXTERIOR)

VIRGINIA DEPARTMENT OF TRANSPORTATION

VDOT ROAD AND BRIDGE STANDARDS	
REVISION DATE 01/09	SHEET 2 OF 3 502.14

STAKE LOCATIONS WHEN STAKING STANDARD MB-11A.
 NOT TO BE USED ON BRIDGE DECKS.
 4 PER PRECAST UNIT.
 1 AT EACH CORNER.

STAKE LOCATIONS WHEN STAKING
 STANDARD MB-11A.
 NOT TO BE USED ON BRIDGE DECKS.
 4 PER PRECAST UNIT.
 1 AT EACH CORNER.

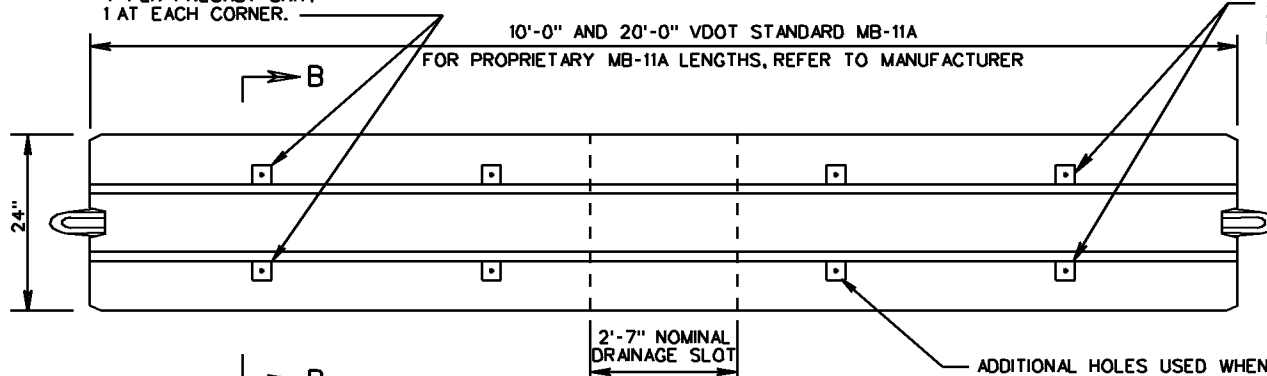

PLAN VIEW

ADDITIONAL HOLES USED WHEN BOLTING TO BRIDGE DECKS.
 FOR BRIDGE DECK INSTALLATIONS, REFER TO SHEETS
 502.13 & 502.14 OF THE ROAD AND BRIDGE STANDARDS.

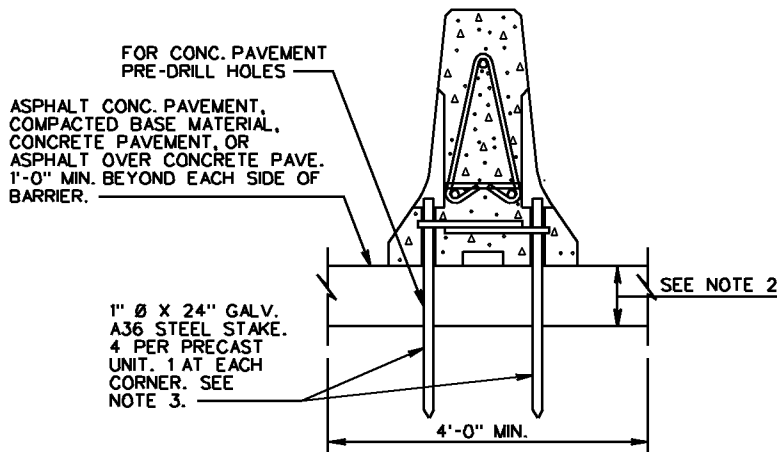

SECTION B-B

TEMPORARY INSTALLATION ON ASPHALT CONCRETE
 PAVEMENT, COMPACTED BASE MATERIAL, CONCRETE
 PAVEMENT, OR ASPHALT OVER CONCRETE PAVEMENT
 (NOT TO BE USED ON BRIDGE DECKS)

NOTES:

1. STAKING OF STANDARD MB-11A TO ASPHALT CONCRETE PAVEMENT, COMPACTED BASE MATERIAL, CONCRETE PAVEMENT, OR ASPHALT OVER CONCRETE PAVEMENT IS REQUIRED WHEN TRAFFIC BARRIER SERVICE CONCRETE IS PLACED WITHIN THE TWO (2) FOOT OFFSET OF A TRENCHING OPERATION (4' OR GREATER IN DEPTH) OR WHEN DETERMINED BY THE ENGINEER.
2. 2" MIN. FOR ASPHALT CONCRETE.
6" MIN. FOR COMPACTED BASE MATERIAL.
3. DRIVE STAKE HEAD BELOW FACE OF BARRIER TO PREVENT SNAGGING.
4. CONTRACTOR TO VERIFY PAVEMENT STRUCTURE PRIOR TO PLACING STAKES.
5. UPON REMOVAL OF THE STAKES AND BARRIERS, REPAIR THE RESULTING HOLES AS FOLLOWS OR AS DIRECTED BY THE ENGINEER. CLEAN AND FILL WITH TYPE EP-4 OR EP-5 EPOXY MORTAR CONFORMING TO THE REQUIREMENTS OF SECTION 24.3 FOR HYDRAULIC CEMENT CONCRETE PAVEMENT AND ASPHALT CONCRETE PAVEMENT. CARE SHALL BE TAKEN NOT TO TRAP AIR WITHIN OR AT THE BOTTOM OF THE EPOXY MORTAR.



ROAD AND BRIDGE STANDARDS

SHEET 3 OF 3

REVISION DATE

502.15

01/09

TRAFFIC BARRIER SERVICE CONCRETE PARAPET
 (DOUBLE FACE)

(FOR TEMPORARY INSTALLATION ON ROADWAYS)

VIRGINIA DEPARTMENT OF TRANSPORTATION

SPECIFICATION
 REFERENCE

105
 512

BARRIER TAPER FROM 50" TALL F-SHAPE TO A STANDARD MB-7A OR MB-7D BARRIER TO BE ACCOMPLISHED WITHIN THE 6'-0" AS INDICATED.

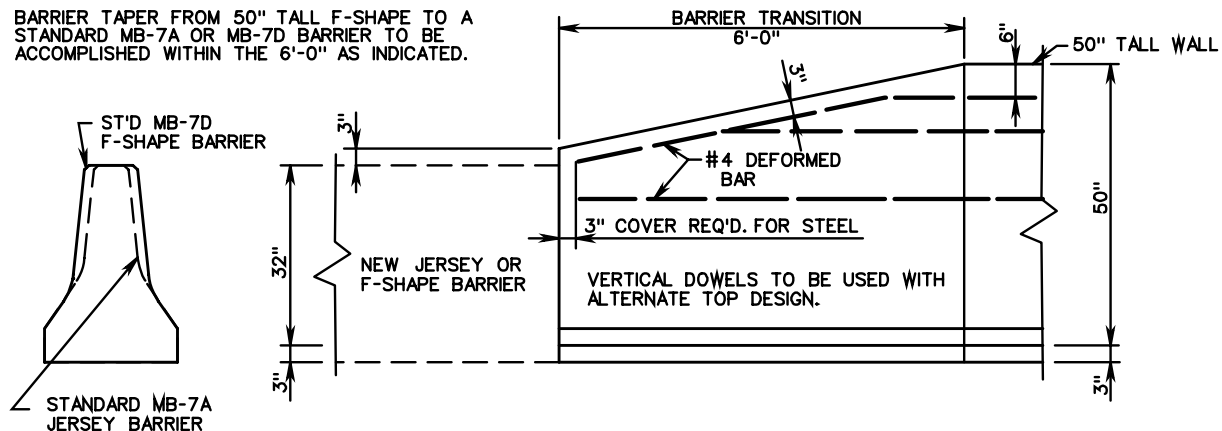

TRANSITION FROM 50" TALL WALL TO 32" JERSEY OR F-SHAPE BARRIER

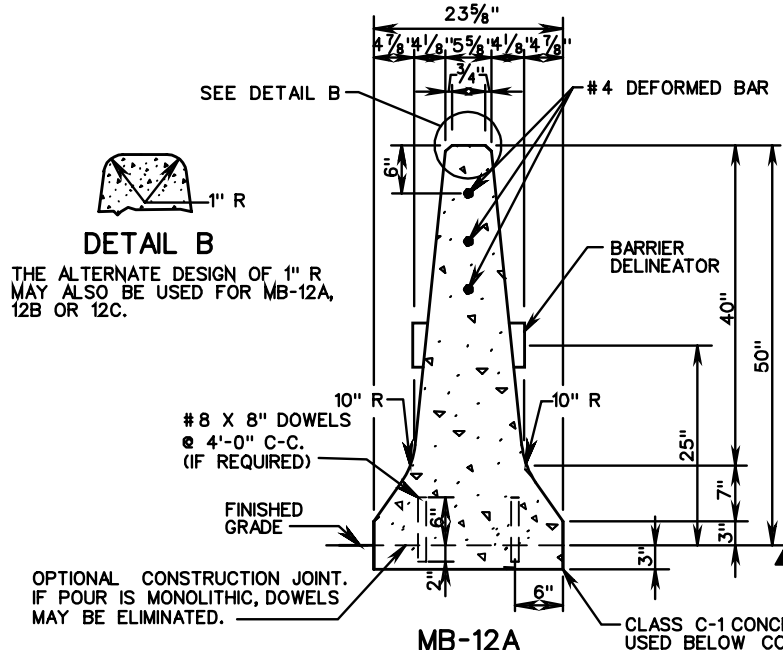
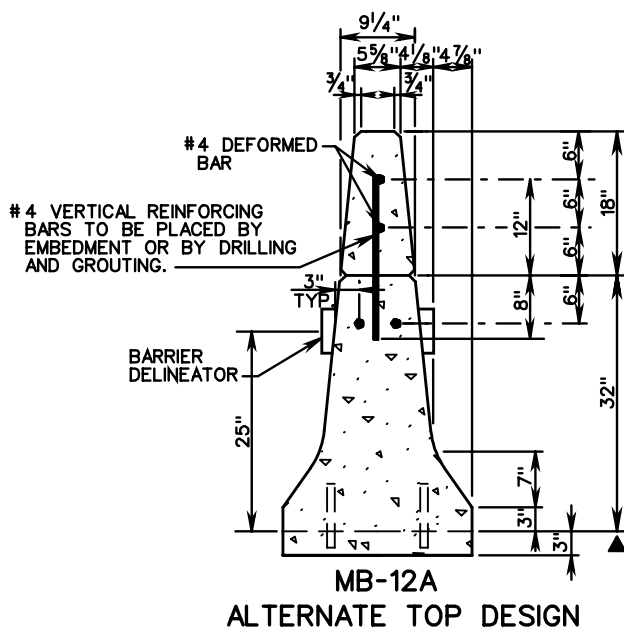

IF BARRIER EXTENSION IS CONSTRUCTED AS A SEPARATE ITEM, ALL JOINTS ARE TO BE CONSTRUCTED AT THE SAME INTERVAL AS CONCRETE BARRIER. ALL VERTICAL BARS ARE #4 AT 24" MAX. SPACING. LENGTH OF DOWELS SHALL BE 20". VERTICAL BARS MAY BE PLACED IN THE CONCRETE OR BONDED INTO DRILLED HOLES IN HARDENED CONCRETE. WHEN HOLES ARE DRILLED NON-SHRINK GROUT SHALL BE USED TO BOND THE BARS IN PLACE.

▲ DEPTH OF CONCRETE BASE MAY BE EXTENDED AT THE CONTRACTOR'S OPTION TO COINCIDE WITH BOTTOM OF PAVEMENT COURSE IN WHICH BASE TERMINATES; HOWEVER, THE COST OF ADDITIONAL CONCRETE SHALL BE INCLUDED IN UNIT PRICE BID PER LINEAR FT. OF BARRIER.

SPECIFICATION REFERENCE
105 502

CONCRETE MEDIAN BARRIER (TALL WALL)

VIRGINIA DEPARTMENT OF TRANSPORTATION

VDOT ROAD AND BRIDGE STANDARDS	
REVISION DATE	SHEET 1 OF 2
502.16	

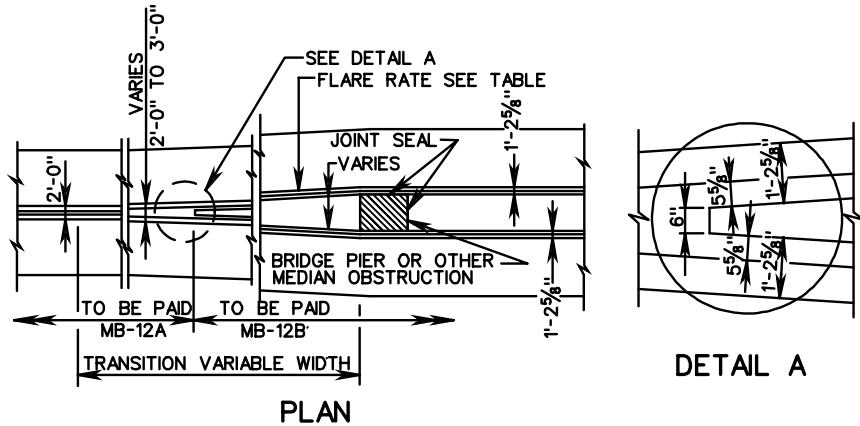

NOTES:

IF THE CONTRACTOR ELECTS TO USE THE OPTIONAL CONSTRUCTION JOINTS, TRANSVERSE JOINTS FOR CRACK CONTROL AND EXPANSION JOINTS ARE TO BE PROVIDED IN BOTH FOOTING AND BARRIER AT THE SAME LOCATION.

TRANSVERSE JOINTS ARE TO COINCIDE WITH JOINTS IN ADJACENT PAVEMENT WITH A MAXIMUM SPACING OF 20 FT. C-C.

CONCRETE MEDIAN BARRIER MAY BE CAST IN PLACE OR SLIP-FORMED.

HORIZONTAL REINFORCING STEEL BARS ARE TO BE SEPARATE AT ALL EXPANSION AND CONTRACTION JOINTS. A 2" CONCRETE COVER IS REQUIRED OVER THE ENDS OF THE REINFORCING STEEL.

BARRIER DELINEATOR SIZE, COLOR AND SPACING SHALL BE IN ACCORDANCE WITH THE SPECIFICATIONS. COST OF DELINEATOR SHALL BE INCLUDED IN THE PRICE BID FOR MEDIAN BARRIER. REFLECTIVE SURFACE OF BARRIER DELINEATOR, IN ALL INSTANCES, SHALL BE FACING THE ONCOMING TRAFFIC.

CONCRETE SHALL BE CLASS A3 IF CAST IN PLACE, 4000 PSI IF PRECAST.

▲ DEPTH OF CONCRETE BASE MAY BE EXTENDED AT THE CONTRACTOR'S OPTION TO COINCIDE WITH BOTTOM OF PAVEMENT COURSE IN WHICH BASE TERMINATES; HOWEVER, THE COST OF ADDITIONAL CONCRETE SHALL BE INCLUDED IN UNIT PRICE BID PER LINEAR FT. OF BARRIER.

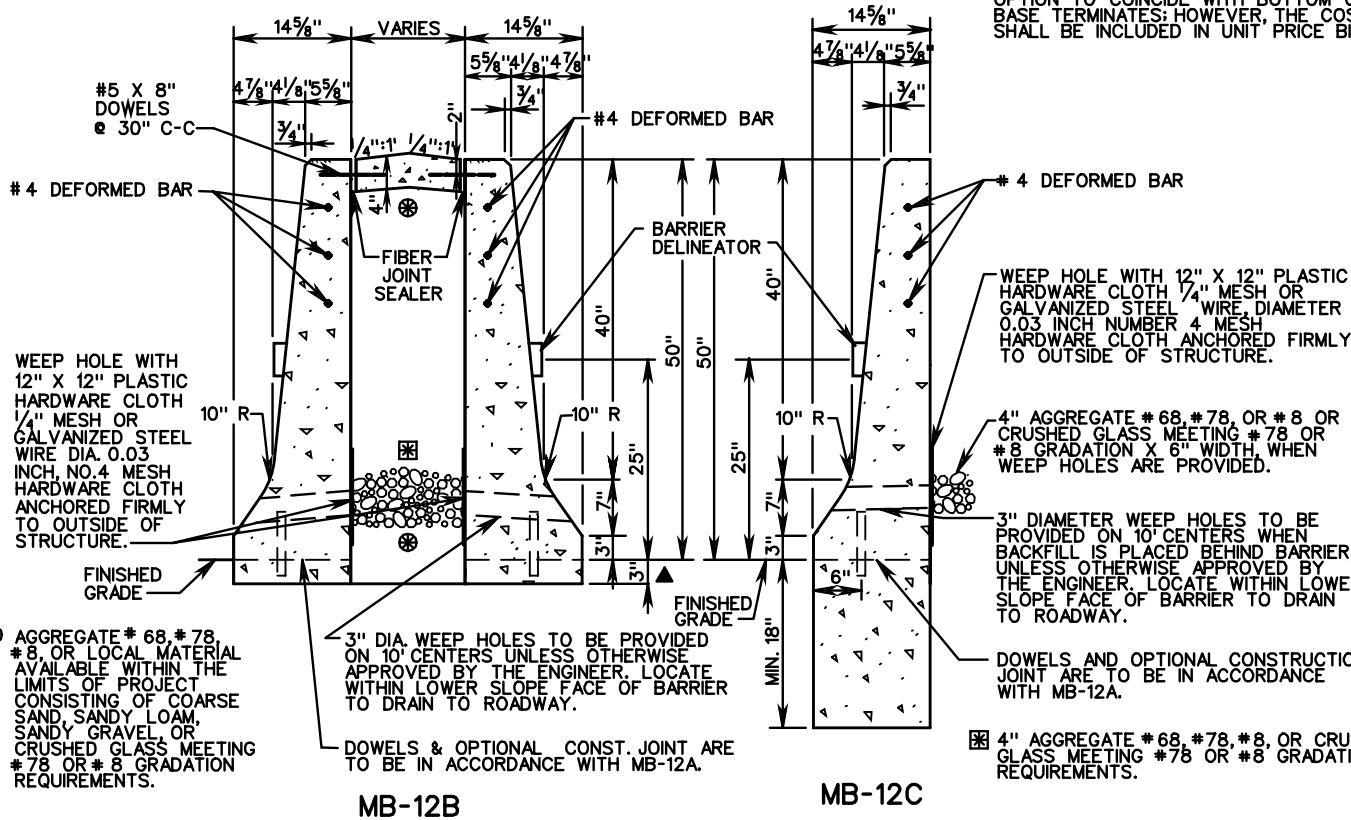

FLARE RATES			
DESIGN SPEED	INSIDE SHY LINE		BEYOND SHY LINE
MPH	SHY LINE LS	FLARE RATE	FLARE RATE
70	10'	30:1	20:1 *
60	8'	26:1	18:1 *
50	6.5'	21:1	14:1 *
40	5'	16:1	10:1 *
30	3.5'	13:1	8:1 *

* SUGGESTED MAXIMUM FLARE RATE FOR RIGID BARRIER SYSTEMS.

CONCRETE MEDIAN BARRIER (TALL WALL)

SPECIFICATION REFERENCE

105
502



ROAD AND BRIDGE STANDARDS

SHEET 2 OF 2

REVISION DATE

502.17

VIRGINIA DEPARTMENT OF TRANSPORTATION

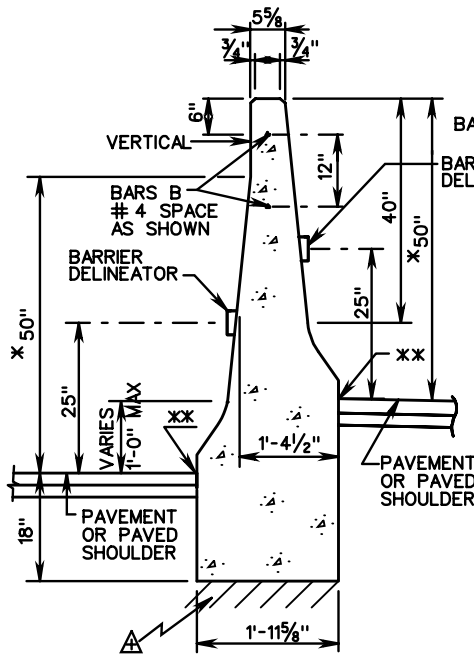

TYPE I
TYPE I (GREATER THAN 0 HT. DIFF., MAX. 1'-0")

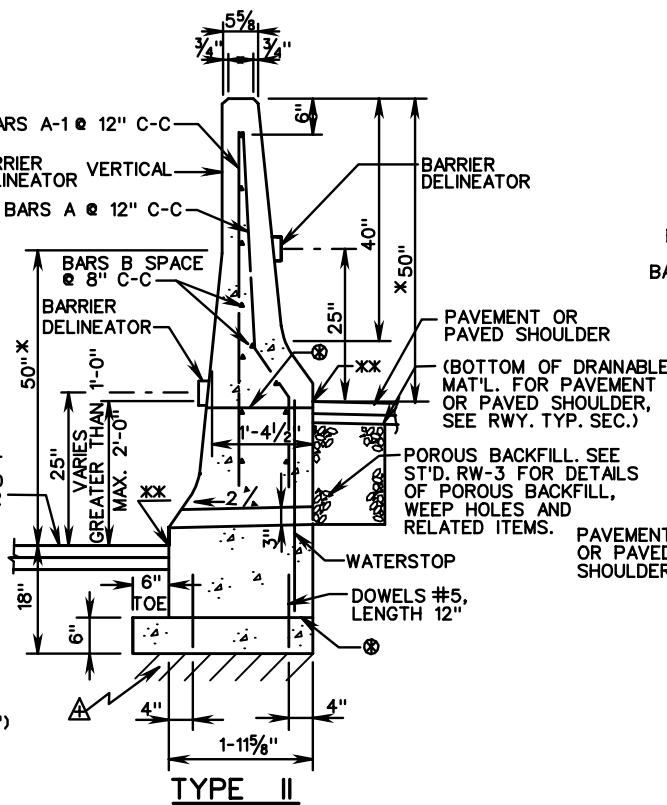

TYPE II
TYPE II (GREATER THAN 1'-0" HT. DIFF., MAX. 2'-0")

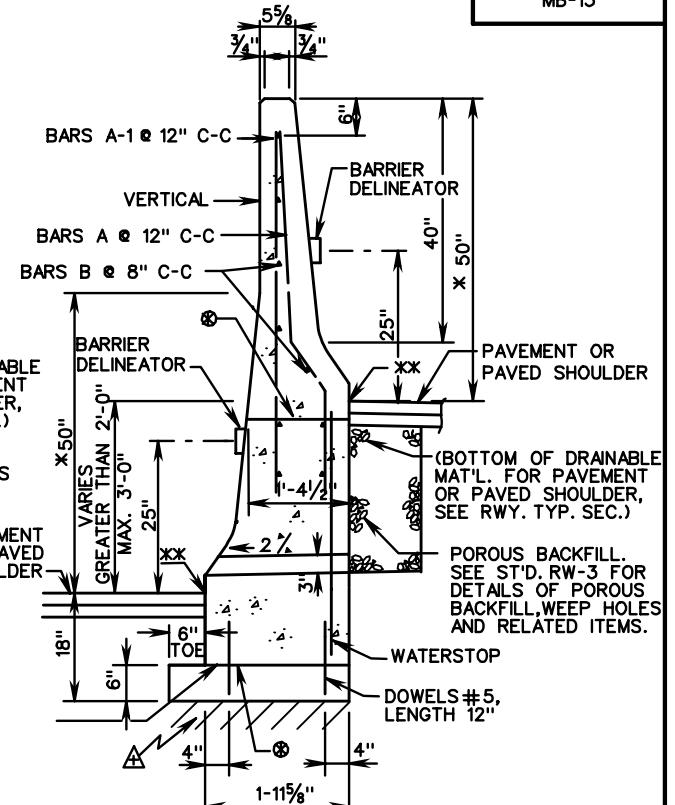

TYPE III
TYPE III (GREATER THAN 2'-0" HT. DIFF., MAX. 3'-0")

* FOR DETAILS OF BARRIER FACE SEE STANDARD MB-12A.

xx DENOTES FINISHED GRADE ELEVATION

△ FOUNDATION MATERIAL UNDER CONCRETE MEDIAN BARRIER IS TO BE COMPACTED

⊗ PERMISSIBLE CONSTRUCTION JOINT TO BE BONDED IN STRICT ACCORDANCE WITH SEC. 404 OF THE CURRENT VDOT ROAD AND BRIDGE SPECIFICATIONS.

BENDING DIAGRAM

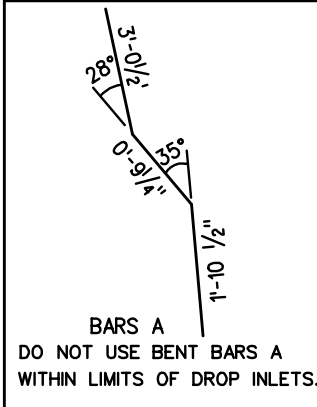

MEASUREMENT AND PAYMENT

MEDIAN BARRIER MB-13 TYPE I, II OR III WILL BE PAID FOR AT THE CONTRACT UNIT PRICE PER LIN. FOOT, WHICH SHALL BE FULL COMPENSATION FOR FURNISHING AND INSTALLING CLASS A3 CONC., REINFORCING STEEL, POROUS BACKFILL AND ALL TOOLS, LABOR, EQUIPMENT AND INCIDENTALS NECESSARY TO COMPLETE THE WORK. ANY ADDITIONAL EXCAVATION, BACKFILL WITH SUITABLE MATERIAL AND COMPACTION WORK NECESSARY FOR THE CONCRETE MEDIAN BARRIER INSTALLATION IS TO BE CONSIDERED INCIDENTAL IN THE PRICE BID FOR THE CONCRETE MEDIAN BARRIER.

REINFORCING STEEL SCHEDULE

PANEL	BARS "A"		BARS A-1		BARS "B"		DOWELS	
	NO.	LENGTH	NO.	LENGTH	NO.	LENGTH	NO.	LENGTH
TYPE I					2	19'-8"		
TYPE II	20	5'-10 1/4"	20	5'-6"	11	19'-8"	40	1'-0"
TYPE III	20	5'-10 1/4"	20	5'-6"	11	19'-8"	40	1'-0"

SPECIFICATION REFERENCE

105
404
502

CONCRETE MEDIAN BARRIER
TYPE I, II OR III

VIRGINIA DEPARTMENT OF TRANSPORTATION

VDOT

ROAD AND BRIDGE STANDARDS

REVISION DATE

SHEET 1 OF 2

502.18

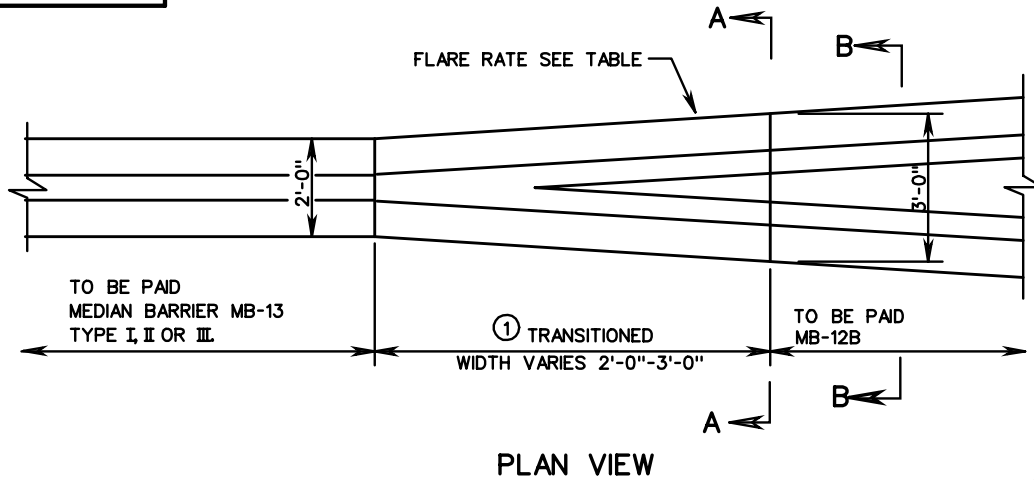

PLAN VIEW

NOTE:

REINFORCING STEEL BARS SHOWN ARE BASED ON A 20' PANEL LENGTH.

ALL REINFORCING BARS ARE TO BE SIZE #4 GRADE 60 STEEL WITH A MINIMUM 1 1/2" CONCRETE COVER.

THE TYPICAL JOINT SPACING FOR CONSTRUCTION JOINTS IS 20' AND 80' FOR EXPANSION JOINTS FOR TYPE II AND III BARRIERS.

FOR DETAILS OF HOW JOINTS ARE TO BE FORMED & WATER STOPS SEE ST'D. RW-3.

TRANSVERSE JOINTS FOR TYPE I BARRIERS SHALL BE CONSTRUCTED IN ACCORDANCE WITH THE ROAD AND BRIDGE SPECIFICATIONS EXCEPT NO SCORING OR SAWING WILL BE ALLOWED.

HORIZONTAL REINFORCING STEEL BARS B ARE TO BE SEPARATED AT ALL EXPANSION & CONTRACTION JOINTS. A 2" CONCRETE COVER IS REQUIRED OVER THE ENDS OF REINFORCING STEEL.

① TRANSITIONED TO BE PAID FOR AS MEDIAN BARRIER MB-13 TYPE I, II OR III.

② MAXIMUM FLARE RATE FOR RIGID BARRIER SYSTEMS.

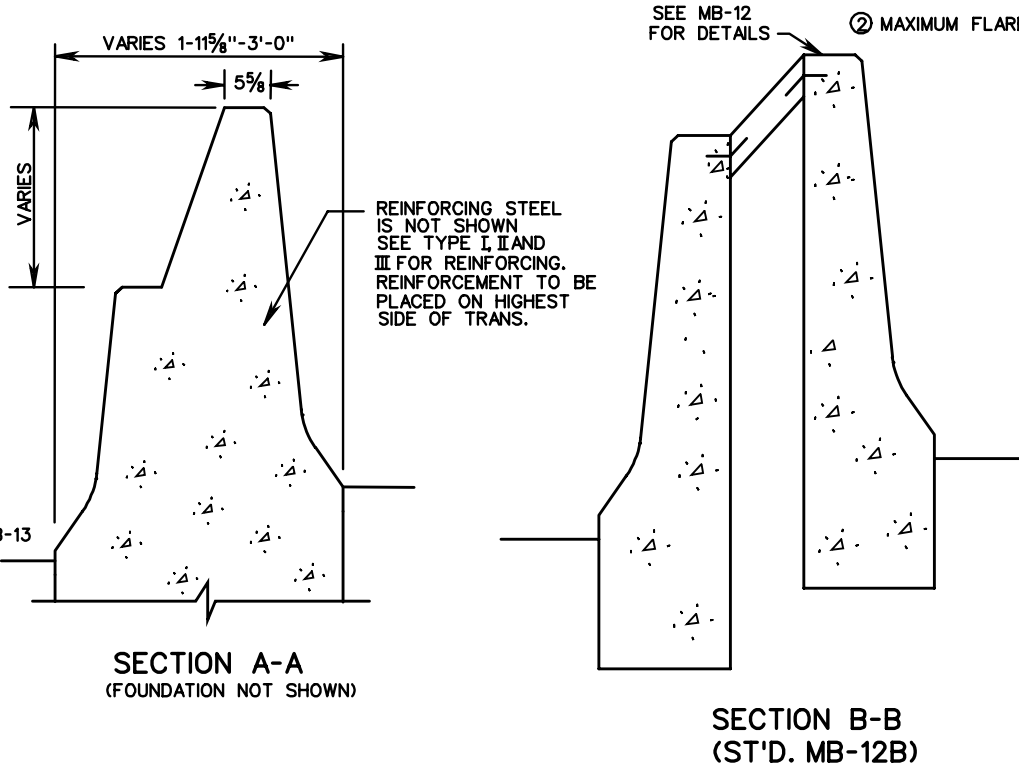

SECTION A-A
(FOUNDATION NOT SHOWN)

SECTION B-B
(ST'D. MB-12B)

FLARE RATES

DESIGN SPEED	INSIDE SHY LINE		Beyond SHY LINE
	SHY LINE LS	FLARE RATE	FLARE RATE
70	10'	30 : 1	20 : 1 ②
60	8'	26 : 1	18 : 1 ②
50	6.5'	21 : 1	14 : 1 ②
40	5'	16 : 1	10 : 1 ②
30	3.5'	13 : 1	8 : 1 ②



ROAD AND BRIDGE STANDARDS

SHEET 2 OF 2

REVISION DATE

502.19

CONCRETE MEDIAN BARRIER

TYPE I, II OR III

VIRGINIA DEPARTMENT OF TRANSPORTATION

SPECIFICATION REFERENCE

105
404
502

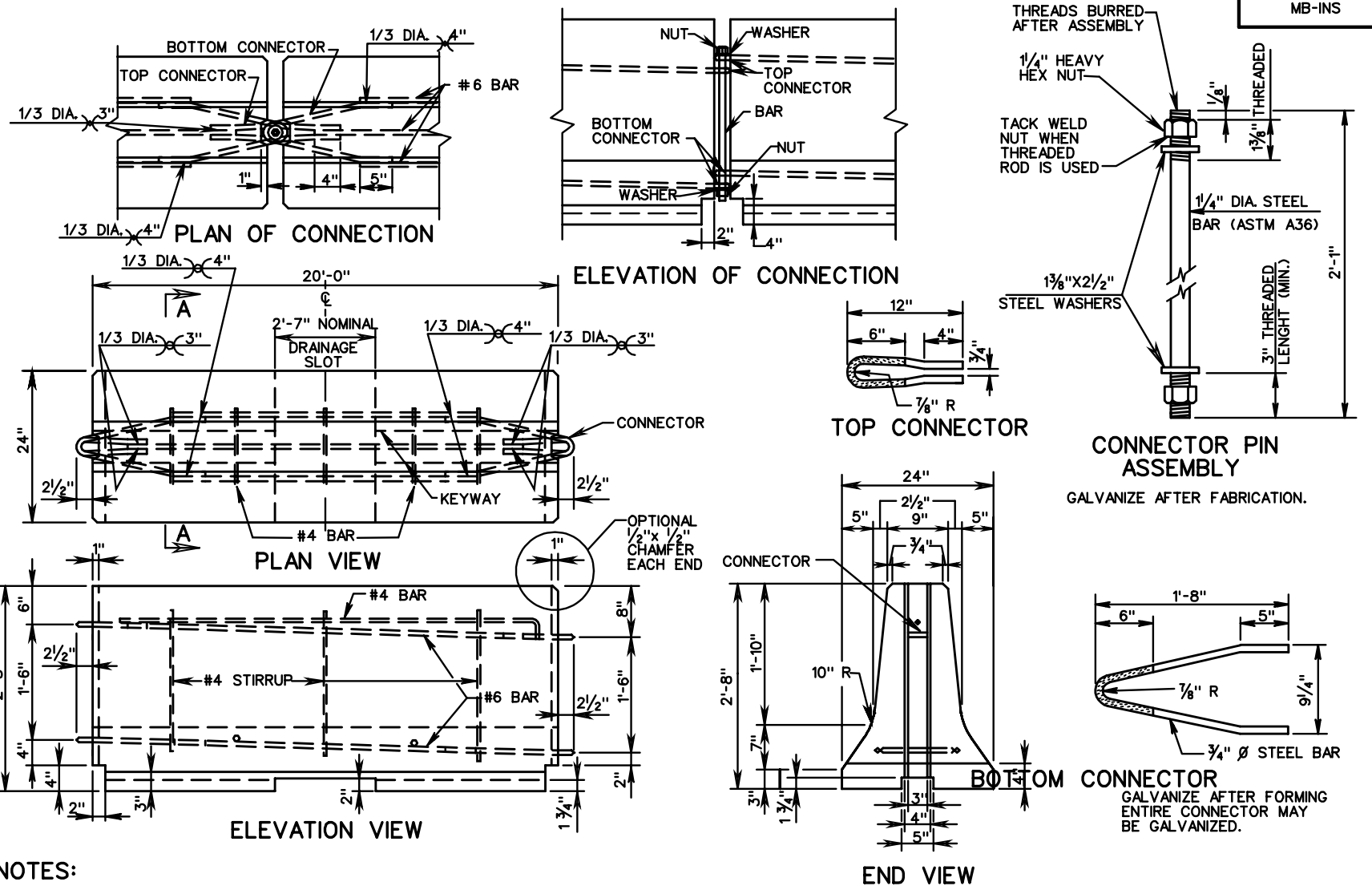

NOTES:

- PIN AND CONNECTORS ARE TO BE ASTM A-36 REINFORCING. STEEL BARS ARE TO BE ASTM A 615, GRADE 60. ONE CONNECTOR PIN ASSEMBLY WITH EACH BARRIER SECTION.
- THE CONNECTION PIN, NUTS AND WASHERS SHALL BE GALVANIZED IN ACCORDANCE WITH AASHTO M-111.
- BEGINNING WITH THE JANUARY 2000 ADVERTISEMENT, ALL POSITIVE CONNECTIONS MUST BE APPROVED BY THE FHWA IN ACCORDANCE WITH NCHRP 350 TEST REQUIREMENTS.

WHEN USING VDOT STANDARD MB-7D PC WITH THE PIN AND LOOP POSITIVE CONNECTION, ALLOW FOR A 6'-0" DYNAMIC DEFLECTION. PROVIDE MIN. 60' OF BARRIER UPSTREAM AND DOWNSTREAM OF WORK ZONE FOR ANCHORAGE. FOR APPROVED NON-VDOT DESIGNS, REFER TO MANUFACTURER'S INSTALLATION INSTRUCTIONS FOR DEFLECTIONS AND ANCHORAGE.

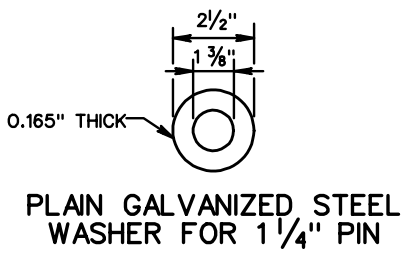

PIN AND LOOP DETAILS

**PRECAST CONCRETE MEDIAN BARRIER
POSITIVE CONNECTION OPTIONS**
VIRGINIA DEPARTMENT OF TRANSPORTATION

SPECIFICATION REFERENCE

VDOT ROAD AND BRIDGE STANDARDS	
REVISION DATE	SHEET 1 OF 5
502.20	

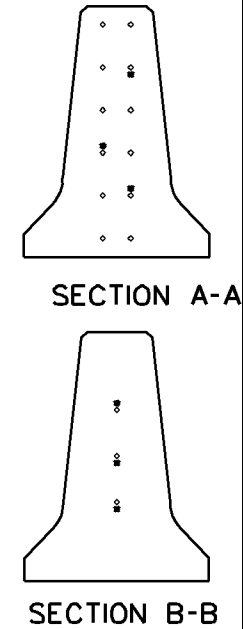
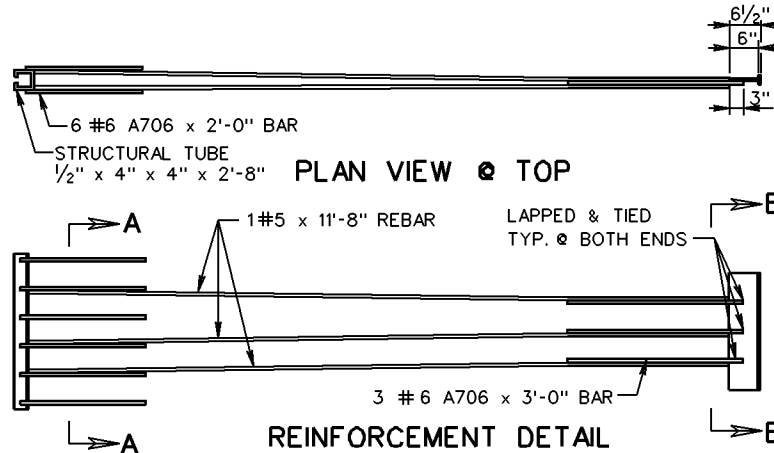
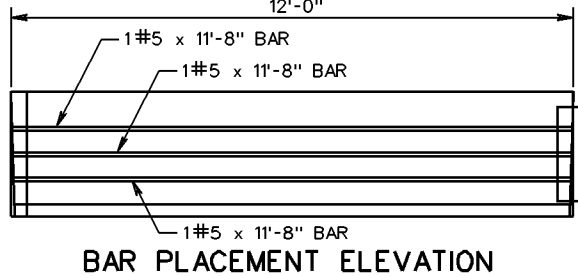
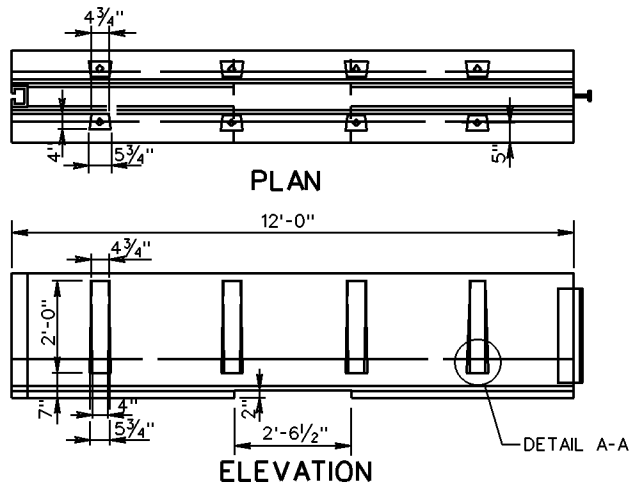

LEGEND	
■	11'-8" BAR
◇	2' AND 3' BAR

NOTES:

1. MINIMUM COMPRESSIVE STRENGTH OF CONCRETE AT THE AGE OF 28 DAYS SHALL BE 4000 PSI.
2. ALL REINFORCEMENT SHALL CONFORM TO ASTM A615, GRADE 60.
3. STANDARD BARRIER SECTIONS SHALL BE 12'-0" AS SHOWN OR 18'-0". SHORTER SECTIONS SHALL BE CAST IN REQUIRED LENGTHS AS ONE UNIT. LONGER SECTIONS SHALL BE CAST TO REQUIRED DIMENSIONS IN TWO UNITS.
4. ALL EXPOSED METAL IS TO BE GALVANIZED FOR PERMANENT LOCATIONS.
5. ALL EXPOSED METAL MAY BE GALVANIZED FOR TEMPORARY LOCATIONS.
6. T-LOK AS MANUFACTURED BY ROCKINGHAM PRECAST
7. BEGINNING WITH JANUARY 2000 ADVERTISEMENT ALL POSITIVE CONNECTIONS MUST BE APPROVED BY THE FHWA IN ACCORDANCE WITH NCHRP 350 TEST REQUIREMENTS.
8. REFER TO MANUFACTURER FOR TEMPORARY INSTALLATION DETAILS.

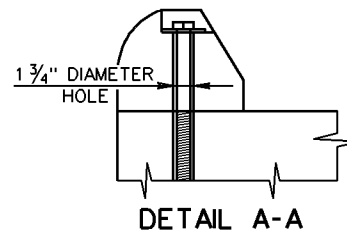
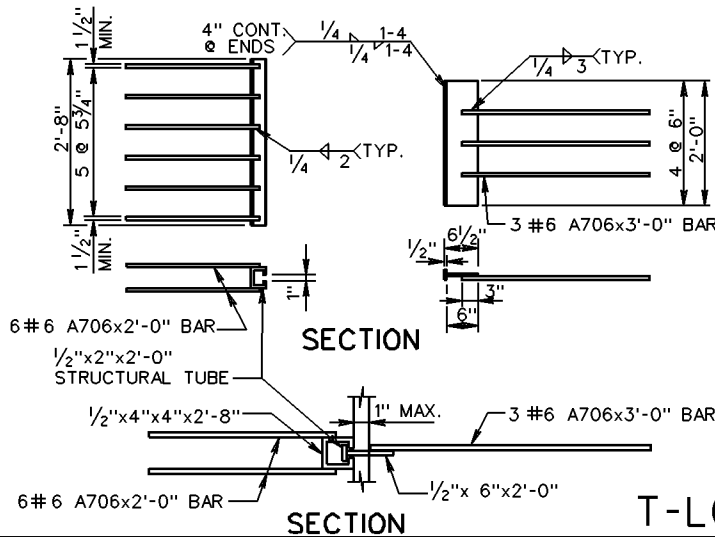
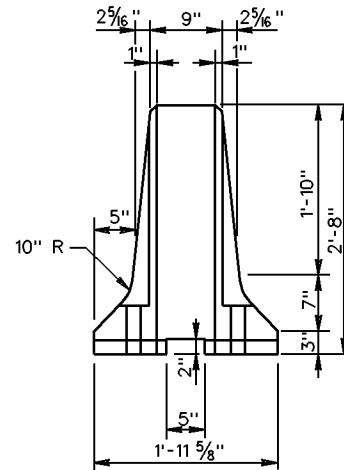

WHEN USING T-LOK BARRIER, ALLOW FOR A 3'-10" DYNAMIC DEFLECTION. PROVIDE MINIMUM 60' OF BARRIER UPSTREAM AND DOWNSTREAM OF WORK ZONE FOR ANCHORAGE.

T-LOK[®] DETAILS

**PRECAST CONCRETE MEDIAN BARRIER
POSITIVE CONNECTION OPTIONS**

VIRGINIA DEPARTMENT OF TRANSPORTATION

SPECIFICATION
REFERENCE



ROAD AND BRIDGE STANDARDS

SHEET 2 OF 5

REVISION DATE

502.21

08/10

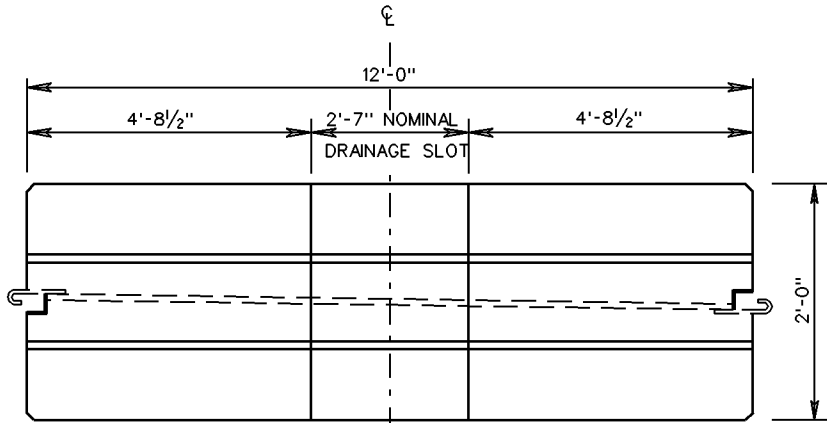

PLAN VIEW

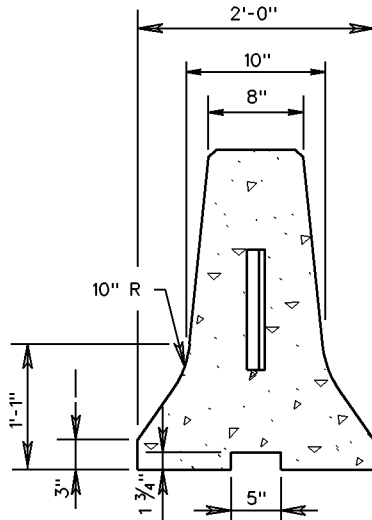

ELEVATION VIEW

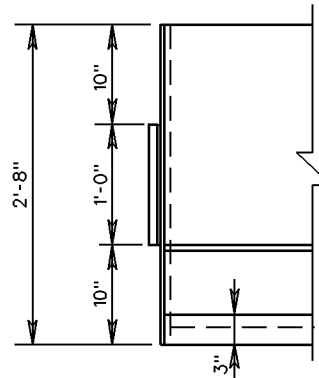

SIDE VIEW

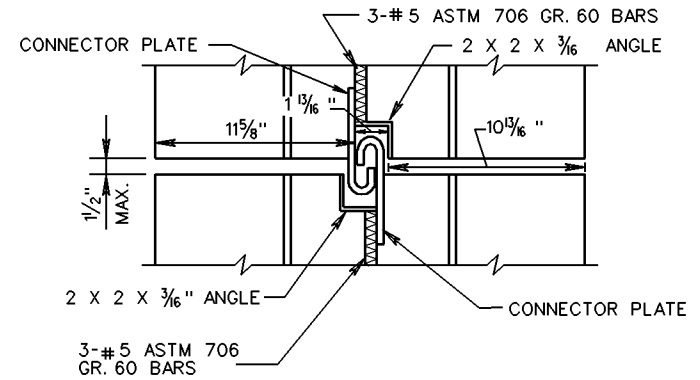

PLAN VIEW

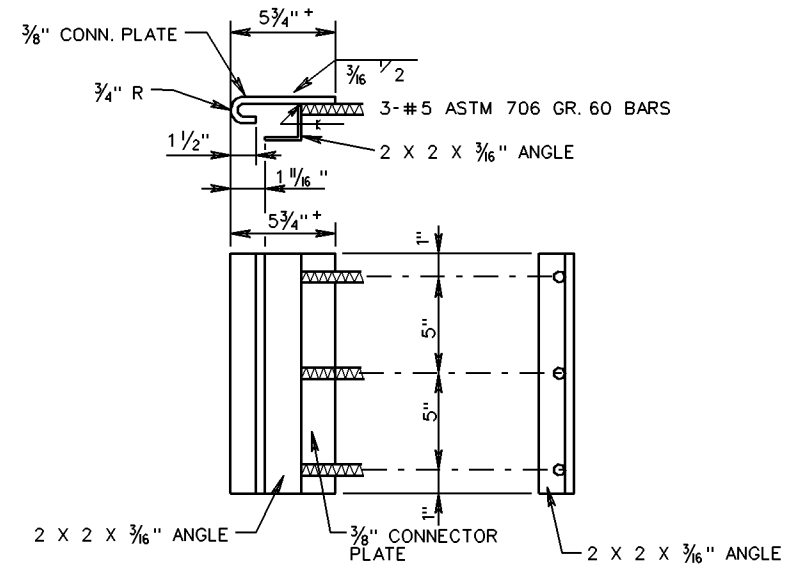

ELEVATION VIEW SIDE VIEW
CONNECTOR PLATE DETAIL

NOTES:

1. MINIMUM COMPRESSIVE STRENGTH OF CONCRETE AT THE AGE OF 28 DAYS SHALL BE 4000 PSI.
2. ALL REINFORCEMENT SHALL CONFORM TO TO ASTM A615, GRADE 60.
3. ALL EXPOSED METAL TO BE GALVANIZED FOR PERMANENT LOCATIONS.
4. ALL EXPOSED METAL MAY BE GALVANIZED FOR TEMPORARY LOCATIONS.
5. J-J HOOK AS MANUFACTURED BY SMITH-MIDLAND.
6. BEGINNING WITH JANUARY 2000 ADVERTISEMENT ALL POSITIVE CONNECTIONS MUST BE APPROVED BY THE FHWA IN ACCORDANCE WITH NCHRP 350 TEST REQUIREMENTS.
7. REFER TO MANUFACTURER FOR TEMPORARY INSTALLATION DETAILS.

WHEN USING J-J HOOK BARRIER, ALLOW FOR A 4'-4" DYNAMIC DEFLECTION. PROVIDE A MIN. 69'-7" OF BARRIER UPSTREAM AND DOWNSTREAM OF WORK ZONE FOR ANCHORAGE.

J-J HOOKTM DETAILS

PRECAST CONCRETE MEDIAN BARRIER
POSITIVE CONNECTION OPTIONS

VIRGINIA DEPARTMENT OF TRANSPORTATION

VDOT

ROAD AND BRIDGE STANDARDS

REVISION DATE

08/10

SHEET 3 OF 5

502.22

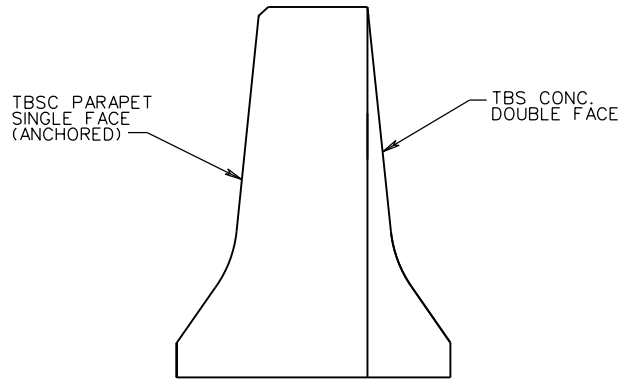

SECTION B-B

- NOTES:
1. BASIS OF PAYMENT:
TRAFFIC BARRIER SERVICE LATERAL SUPPORT WILL BE MEASURED AND PAID FOR IN UNITS OF EACH COMPLETE IN PLACE AND SHALL INCLUDE FURNISHING AND PLACING PRECAST CONCRETE BARRIERS (TBS CONCRETE) AND MAINTENANCE, REMOVAL WHEN NO LONGER NECESSARY, AND ALL MATERIALS, LABOR, TOOLS, EQUIPMENT, AND INCIDENTALS NECESSARY TO COMPLETE THE WORK.
 2. FOR POSITIVE CONNECTION DETAILS AND DIMENSIONS SEE STANDARD MB-INS, SHEETS 502.20 - 502.22
 3. FOR DIMENSIONS NOT SHOWN, REFER TO ST'D. MB-7D AND MB-10A.

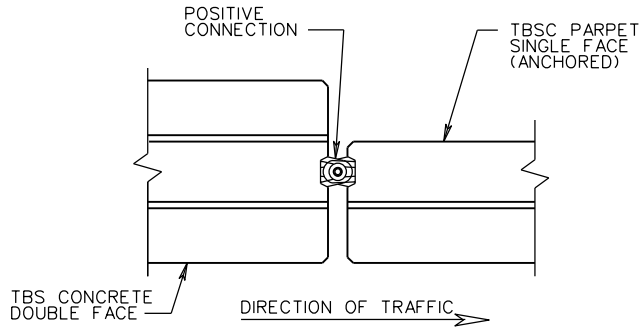

PLAN OF POSITIVE CONNECTION

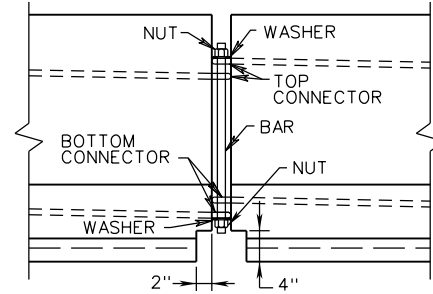

ELEVATION OF POSITIVE CONNECTION

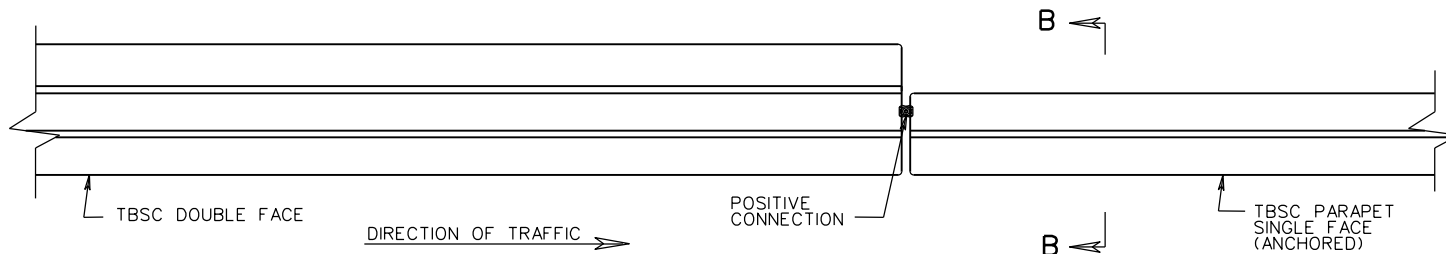

PLAN VIEW METHOD A



ROAD AND BRIDGE STANDARDS

SHEET 4 OF 5

REVISION DATE

502.23

7/12

BUTTING TRAFFIC BARRIER SERVICE TO SINGLE FACE PARAPET SERVICE

VIRGINIA DEPARTMENT OF TRANSPORTATION

SPECIFICATION REFERENCE

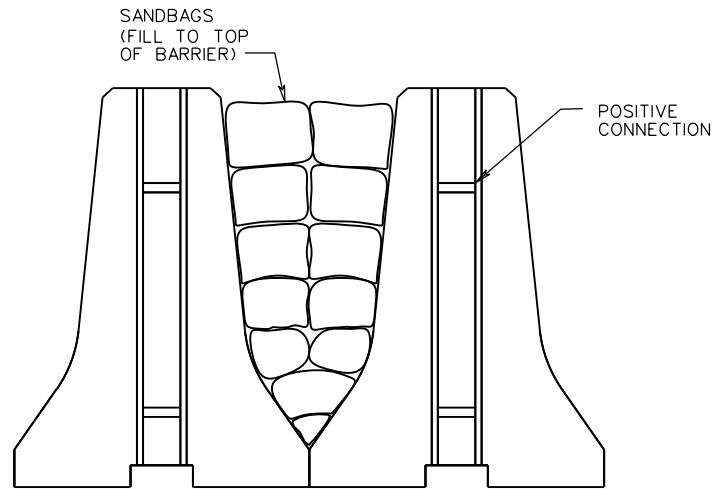

SECTION A-A



NOTES:

1. BASIS OF PAYMENT:
TRAFFIC BARRIER SERVICE LATERAL SUPPORT WILL BE MEASURED AND PAID FOR IN UNITS OF EACH COMPLETE IN PLACE AND SHALL INCLUDE FURNISHING AND PLACING PRECAST CONCRETE BARRIERS (TBS CONCRETE) AND SAND BAGS, MAINTENANCE, REMOVAL WHEN NO LONGER NECESSARY, AND ALL MATERIALS, LABOR, TOOLS, EQUIPMENTS, AND INCIDENTALS NECESSARY TO COMPLETE THE WORK.
2. FOR POSITIVE CONNECTION DETAILS AND DIMENSIONS SEE STANDARD MB-INS, SHEETS 502.20 - 502.22
3. FOR DIMENSIONS NOT SHOWN, REFER TO ST'D. MB-7D AND MB-10A.

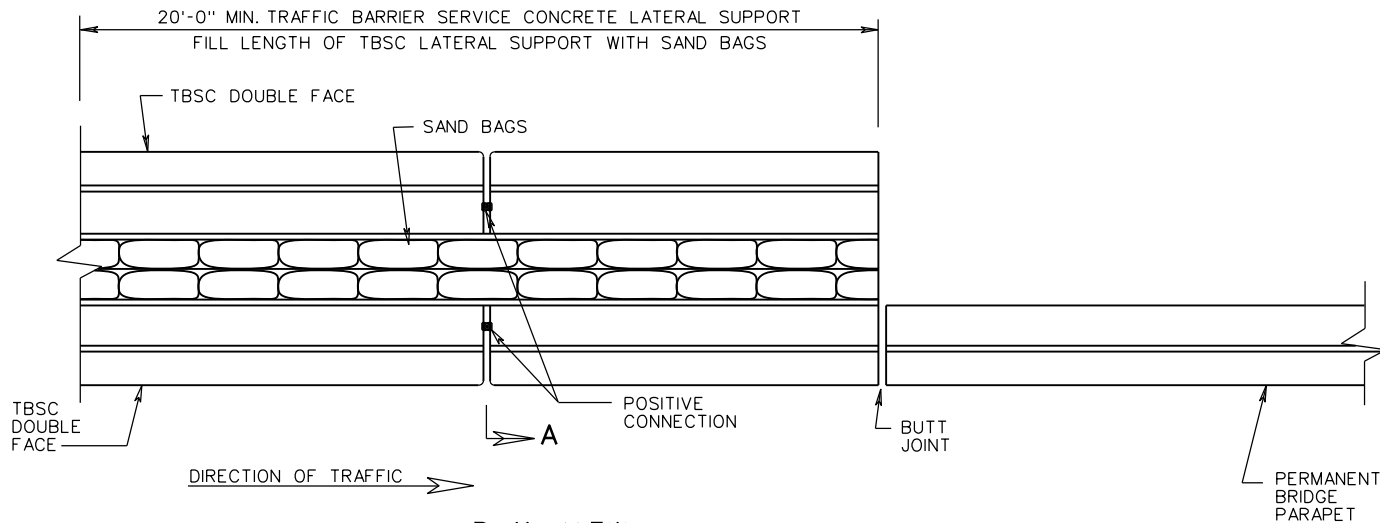

PLAN VIEW
METHOD B

SPECIFICATION
REFERENCE

A COPY OF THE ORIGINAL SEALED AND SIGNED DRAWING IS ON FILE IN THE CENTRAL OFFICE.

**BUTTING TRAFFIC BARRIER SERVICE
TO SINGLE FACE PARAPET SERVICE**

VIRGINIA DEPARTMENT OF TRANSPORTATION

VDOT

ROAD AND BRIDGE STANDARDS

REVISION DATE

7/11

SHEET 5 OF 5

502.24

THIS PAGE INTENTIONALLY LEFT BLANK



ROAD AND BRIDGE STANDARDS

SHEET 1 OF 1

REVISION DATE

502.25

VIRGINIA DEPARTMENT OF TRANSPORTATION

SPECIFICATION
REFERENCE

GENERAL NOTES - FENCING

FARM FENCE

BARBED WIRE

BARBED WIRE IS TO CONFORM TO ONE OF THE TYPES ALLOWED BY THE SPECIFICATIONS. UNLESS OTHERWISE NOTED ON PLANS FOUR STRANDS WILL BE PROVIDED. SPACING OF STRANDS SHOWN IS SUGGESTED ONLY. ANY OTHER SPACING APPROVED BY THE ENGINEER MAY BE USED.

WOOD POSTS

WOOD POSTS TO BE SQUARE CUT OR ROUND TO THE DIMENSIONS SHOWN ON THE DRAWINGS.

POSTS TOPS MAY BE FLAT OR CUT AT A 30° ANGLE.

FOR WOVEN WIRE FABRIC, STAPLES ARE TO BE USED AT TOP AND BOTTOM STRANDS AND AT A MINIMUM OF THREE INTERMEDIATE STRANDS PER POST.

ONE STAPLE PER STRAND IS TO BE USED FOR BARBED WIRE FENCE.

WHERE GATE, CORNER, OR BRACE POSTS FALL IN ROCK OR MARSHY AREAS THEY SHALL BE SET IN CLASS A3 OR C1 CONCRETE.

METAL POSTS

METAL POSTS ARE TO BE ONE OF THE TYPES SHOWN ON THE STANDARD DRAWINGS AND CONFORMING TO THE SPECIFICATIONS.

AT EACH CORNER AND STRETCHER POST WIRE FABRIC IS TO BE CUT AND ALL HORIZONTAL STRANDS SECURELY WRAPPED AROUND POST.

BRACES ON CORNER, STRETCHER AND END POSTS ARE TO BE SECURED 1'-6" FROM TOP OF POST WITH 1/2" BOLTS.

IN LIEU OF SETTING POSTS IN CONCRETE, MANUFACTURER'S ANCHORING DEVICES MEETING THE SPECIFICATION REQUIREMENTS MAY BE USED WHEN APPROVED BY THE ENGINEER.

BRACES

MAXIMUM SPACING BETWEEN BRACES TO BE 500'.

CORNER BRACES TO BE PROVIDED WHERE CORNER ANGLE IS 15° OR OVER.

LINE BRACES TO BE PROVIDED WHERE VERTICAL ALIGNMENT CHANGES 15° OR MORE AND WHERE SPACING REACHES 500'.

MISCELLANEOUS

FENCE IS TO BE LOCATED AS SHOWN ON THE PLANS OR DIRECTED BY THE ENGINEER.

THE SIDE OF THE POST TO WHICH FABRIC IS TO BE ATTACHED WILL BE DETERMINED BY THE ENGINEER.

FENCE TO BE GROUNDED IN ACCORDANCE WITH DETAIL SHOWN ON STANDARD FE-6 WHERE REQUIRED.

UNLESS SPECIFIED ON PLANS, THE CONTRACTOR WILL HAVE THE OPTION OF FURNISHING EITHER METAL OR WOOD POSTS. POSTS TYPES ARE NOT TO BE INTERMIXED ON ANY ONE INSTALLATION.

CHAIN LINK FENCE

WIRE FABRIC

WIRE FABRIC SHALL HAVE A 2" MESH.

MISCELLANEOUS

IN LIEU OF SETTING POSTS IN CONCRETE, MANUFACTURER'S ANCHORING DEVICES MEETING THE SPECIFICATION REQUIREMENTS MAY BE USED WHEN APPROVED BY THE ENGINEER.

FOR GATES EXCEEDING 6'-0" IN WIDTH ROLLED FORMED STEEL POST WILL NOT BE ALLOWED.

CHAIN LINK FENCE TO BE GROUNDED IN ACCORDANCE WITH DETAILS SHOWN ON STANDARD FE-6, WHERE REQUIRED.

SPECIFICATION
REFERENCE

STANDARD FENCE GENERAL NOTES

VIRGINIA DEPARTMENT OF TRANSPORTATION

VDOT

ROAD AND BRIDGE STANDARDS

REVISION DATE

SHEET 1 OF 1

503.01

FE-W1,W2

CORNER BRACE

LINE BRACE

LINE BRACE AT END LOCATION

WOOD POST

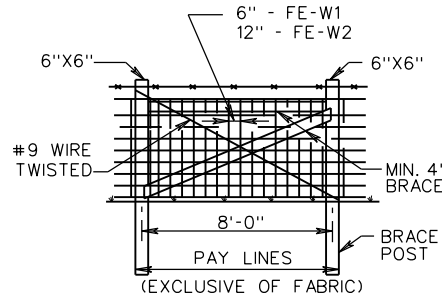
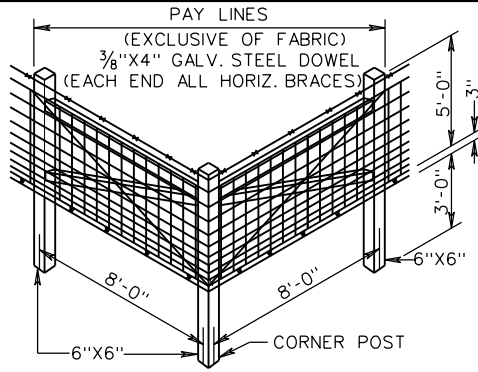

THE BRACE WIRE TO BE PLACED AROUND POSTS WITH ONE WIRE ON EACH SIDE OF BRACE. WIRE TO BE DRAWN TAUT BY TWISTING BETWEEN BRACE AND EACH POST. THIS APPLIES TO ALL BRACE WIRES.
DIAGONAL 4" BRACES TO BE PLACED IN DIRECTION OF PULL. POST TO BE NOTCHED FOR DIAGONAL 4" BRACES. ALL 4" DIAGONAL BRACES TO HAVE TWO GALVANIZED 12D NAILS EACH END.

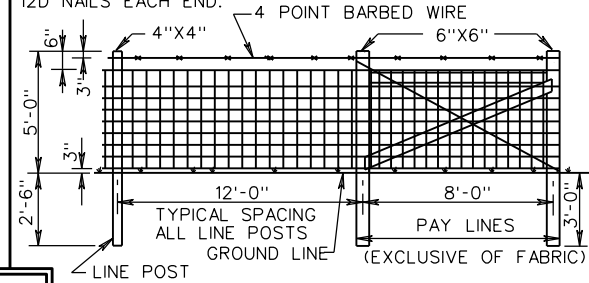

METAL POST

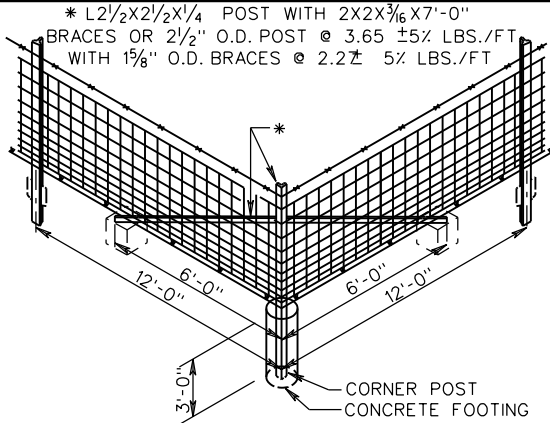

IF NOT OTHERWISE NOTED DIMENSIONS AND DESCRIPTIONS SHOWN ON ONE DRAWING APPLY TO OTHER DETAILS WITH THE SAME POST TYPE.

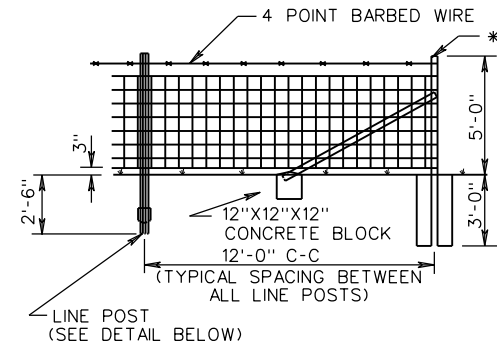
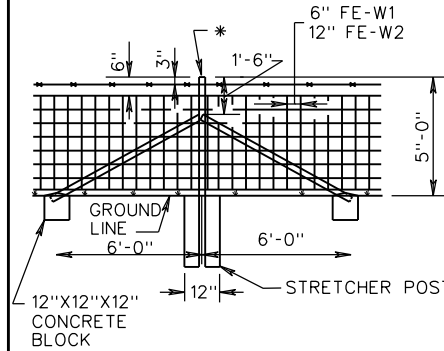

NOTES:

SEE GENERAL NOTES-FENCING FOR ADDITIONAL DETAILS AND INSTRUCTIONS.

LINE POSTS ARE TO BE OF THE TYPES SHOWN OR EQUIVALENT MEETING THE APPROVAL OF THE ENGINEER.

ALL POSTS ARE TO HAVE A MINIMUM WEIGHT OF 1.25 LBS./FT.

A MINIMUM OF FIVE CLAMPS FOR ATTACHING FABRIC TO POST ARE TO BE INCLUDED IN COST OF EACH LINE POST.

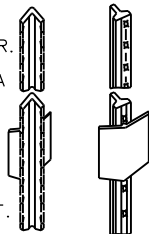

FLANGED FLANGE TYPE "U" TYPE "T"

METAL LINE POST

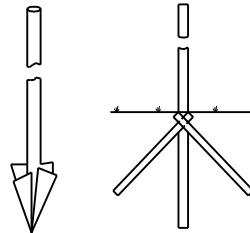

FOR USE IN LIEU OF SETTING POSTS IN CONCRETE. DEVICES SHOWN ARE REPRESENTATIONAL ONLY. SEE GENERAL NOTES.

ALTERNATE ANCHOR DEVICES

L2X2X3/8 TO BE CUT TO FIT AROUND L2 1/2 X 2 1/2 X 1/4 STRETCHER POST.

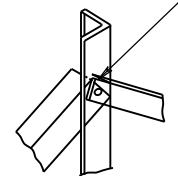

L2 1/2 X 2 1/2 X 1/4, 2" LONG BRACKET BOLTED TO STRETCHER POST

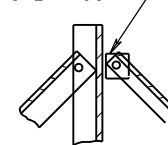

ALTERNATE

METHOD OF ATTACHING ANGLE BRACES TO STRETCHER POSTS



ROAD AND BRIDGE STANDARDS

SHEET 1 OF 1

REVISION DATE

503.02

7/13

**STANDARD FENCE
WOVEN WIRE FABRIC**

VIRGINIA DEPARTMENT OF TRANSPORTATION

SPECIFICATION REFERENCE

242
507
236

		CORNER BRACE	LINE BRACE	LINE BRACE AT END LOCATION	FE-B
WOOD POST			<p>DIAGONAL 4" BRACE TO BE PLACED IN DIRECTION OF PULL.</p> <p>POST TO BE NOTCHED FOR DIAGONAL 4" BRACES. ALL DIAGONAL 4" BRACES TO HAVE TWO GALVANIZED 12D NAILS AT EACH END.</p>	<p>THE BRACE WIRE TO BE PLACED AROUND POSTS WITH ONE WIRE ON EACH SIDE OF BRACE. WIRE TO BE DRAWN TAUT BY TWISTING BETWEEN BRACE AND EACH POST. THIS APPLIES TO ALL BRACE WIRES.</p>	
		<p>IF NOT OTHERWISE NOTED DIMENSIONS AND DESCRIPTIONS SHOWN ON ONE DRAWING APPLY TO OTHER DETAILS WITH THE SAME POST TYPE.</p>			
METAL POST		<p>* L2 1/2 X 2 1/2 X 1/4 POST WITH L2 X 2 X 3/16 X 7'-0" BRACES OR 2 1/2" O.D. POST @ 3.65 ± 5% LBS./FT. WITH 1 5/8" O.D. BRACES @ 2.27 ± 5% LBS./FT.</p>			
		<p>FLANGED "U" TYPE</p> <p>"T" TYPE</p> <p>LINE POSTS ARE TO BE OF THE TYPES SHOWN OR EQUIVALENT MEETING THE APPROVAL OF THE ENGINEER.</p> <p>ALL POSTS ARE TO HAVE A MINIMUM WEIGHT OF 1.25 LBS./FT.</p> <p>A MINIMUM OF FIVE CLAMPS FOR ATTACHING FABRIC TO POST ARE TO BE INCLUDED IN COST OF EACH LINE POST.</p> <p>NOTES: SEE GENERAL NOTES FENCING FOR ADDITIONAL DETAILS AND INSTRUCTIONS.</p> <p>METAL LINE POST</p>	<p>L2 X 2 X 3/16 TO BE CUT TO FIT AROUND L2 1/2 X 2 1/2 X 1/4 STRETCHER POST.</p> <p>L2 1/2 X 2 1/2 X 1/4, 2" LONG BRACKET BOLTED TO STRETCHER POST</p> <p>ALTERNATE</p> <p>METHOD OF ATTACHING ANGLE BRACES TO STRETCHER POSTS</p>	<p>FOR USE IN LIEU OF SETTING POSTS IN CONCRETE. DEVICES SHOWN ARE REPRESENTATIONAL ONLY. SEE GENERAL NOTES.</p> <p>ALTERNATE ANCHOR DEVICES</p>	
SPECIFICATION REFERENCE	<h1>STANDARD FENCE</h1> <h2>BARBED WIRE</h2> <p>VIRGINIA DEPARTMENT OF TRANSPORTATION</p>				
242 507 236					<p>VDOT</p> <p>ROAD AND BRIDGE STANDARDS</p> <p>REVISION DATE</p> <p>SHEET 1 OF 1</p> <p>503.03</p>

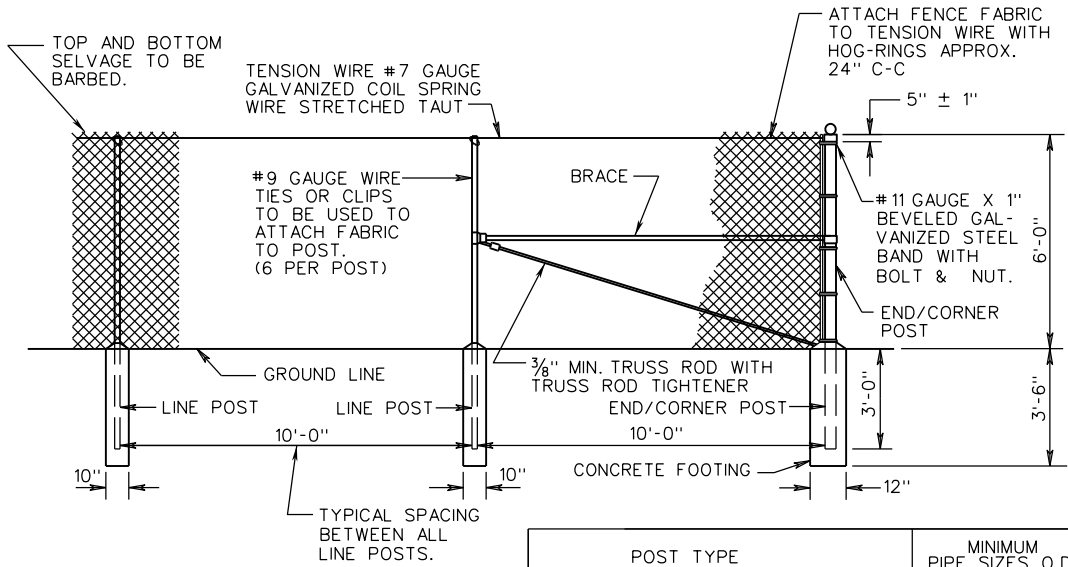

POST TYPE	MINIMUM PIPE SIZES O.D.
LINE POST	2.375"
END/CORNER POST	2.875"
GATE POST (SINGLE SWING) w ≤ 6ft.	2.875"
GATE POST (SINGLE SWING) w > 6ft.	4.00"
GATE POST (DOUBLE SWING)	2.875"
BRACE	1.66"
GATE FRAME	1.90"

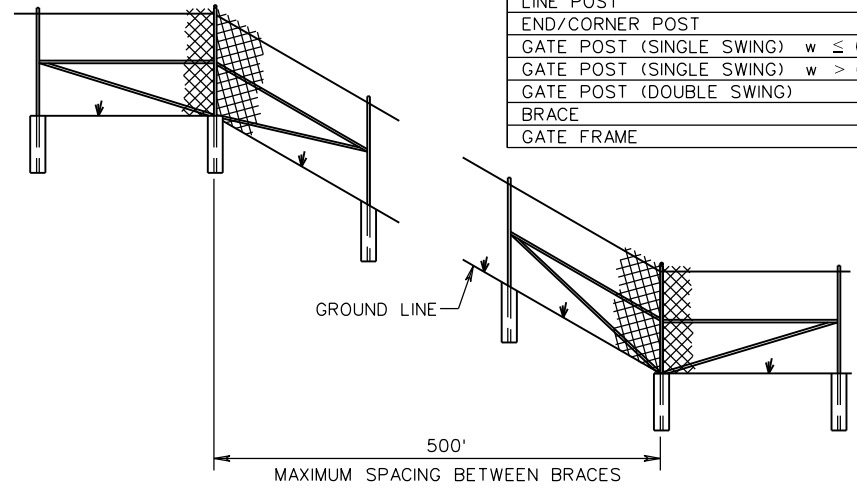

ALTERNATE ANCHOR DEVICES MAY BE USED IN LIEU OF SETTING POST IN CONCRETE. DEVICES SHOWN ARE REPRESENTATIONAL ONLY. SEE GENERAL NOTES.

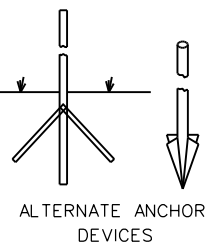

NOTES:
 SEE GENERAL NOTES-FENCING FOR ADDITIONAL DETAILS AND INSTRUCTIONS
 A MOISTURE-EXCLUDING CAP IS REQUIRED ON TUBULAR POSTS.
 MATERIAL FOR CAP SHALL CONFORM TO THE ALLOWABLE TYPES FOR OTHER LISTED FITTINGS.
 CORNER BRACE - TO BE USED WHEN HORIZONTAL ALIGNMENT CHANGES 15° OR MORE.
 LINE BRACE - TO BE USED WHEN VERTICAL ALIGNMENT CHANGES 15° OR MORE
 END/ CORNER POSTS SHALL BE USED WITH ALL LINE AND CORNER BRACES
 BRACES SHALL BE INSTALLED HALF THE HEIGHT ABOVE THE GROUND LINE OF THE POST WHEN A TOP RAIL IS USED, OR TWO THIRDS THE HEIGHT ABOVE THE GROUND LINE WHEN A TENSION WIRE IS USED IN LIEU OF A TOP RAIL.
 CHAIN LINK FENCE GREATER THAN 6 FEET IN HEIGHT SHALL BE SUBMITTED TO THE STANDARDS & SPECIAL DESIGN SECTION FOR APPROVAL.

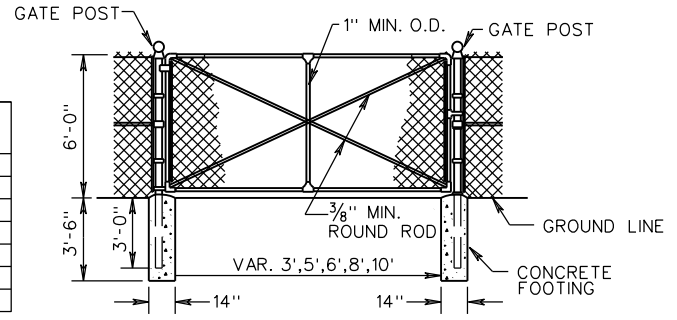

SINGLE SWING GATE

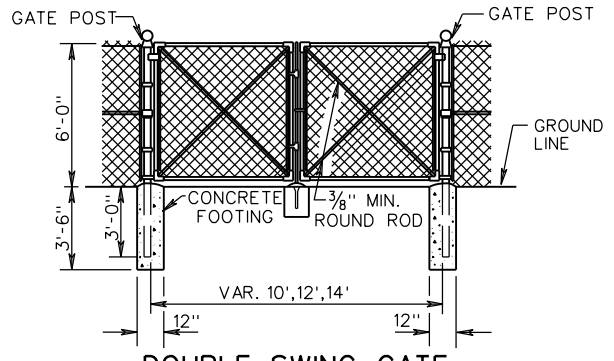

DOUBLE SWING GATE

(TO BE USED WHERE SWINGING CLEARANCE IS LIMITED)



STANDARD FENCE
 CHAIN LINK

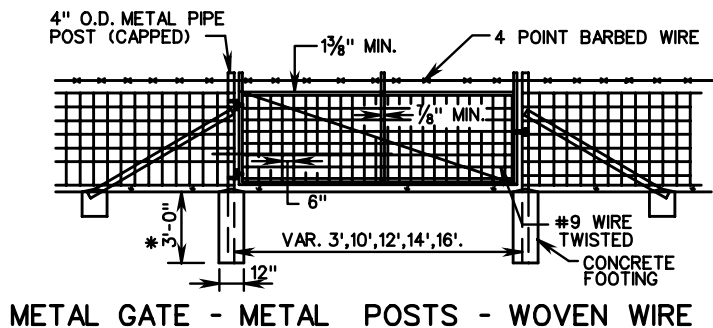

METAL GATE - METAL POSTS - WOVEN WIRE

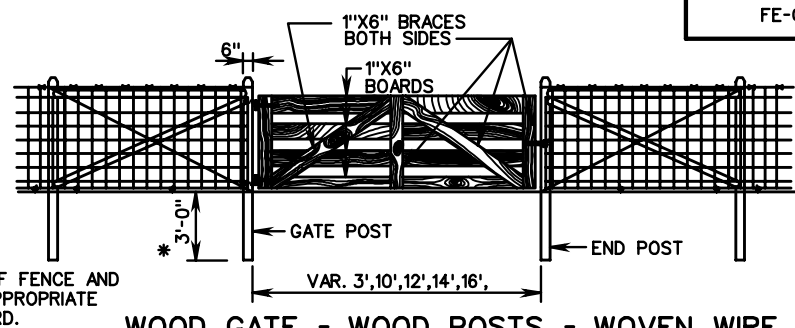

WOOD GATE - WOOD POSTS - WOVEN WIRE

* IF GATE WIDTH EXCEEDS 12', GATE POST IS TO BE SET 3'-6" INTO GROUND HEIGHT OF GATE POST ABOVE GROUND DEPENDS ON TYPE OF FENCE USED- 5'-0", WOVEN WIRE FABRIC, 4'-6", BARBED WIRE.

FOR DETAILS OF FENCE AND BRACES SEE APPROPRIATE FENCE STANDARD.

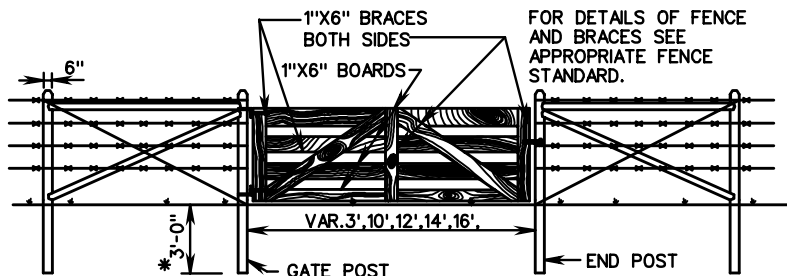

WOOD GATE - WOOD POSTS - BARBED WIRE

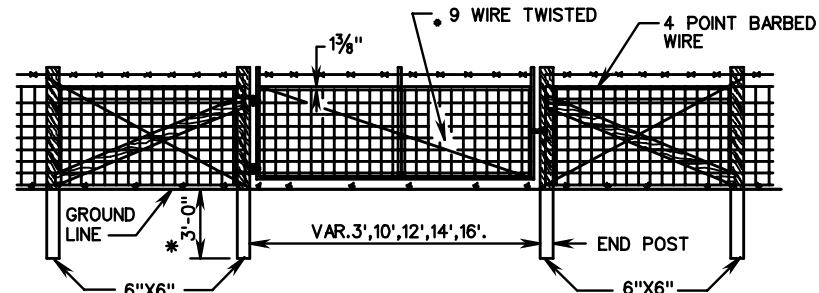

METAL GATE - WOOD POSTS - WOVEN WIRE

FOR DETAILS OF FENCE AND BRACES SEE APPROPRIATE FENCE STANDARD.

WOOD GATE

BRACES ARE TO BE BOLTED AT EXTREMITIES AND INTERSECTIONS WITH A MIN. OF (2) 5/8" DIA. GALV. BOLTS, NUTS, AND WASHERS. ALL OTHER POINTS OF CONTACT ARE TO BE NAILED FROM BOTH SIDES WITH A MIN. OF 3-10D GALV. NAILS.

LUMBER FOR GATE IS TO BE ANY DRESSED, TRUE TYPE MEETING THE APPROVAL OF THE ENGINEER IT IS TO BE TREATED WITH PRESERVATIVES OTHER THAN CREOSOTE.

WOOD GATE IS TO HAVE TWO COATS OF EXTERIOR WHITE PAINT UNLESS OTHERWISE DIRECTED BY THE ENGINEER. PAINT IS TO MEET THE REQUIREMENTS OF THE CURRENT ROAD AND BRIDGE SPECIFICATIONS.

METAL GATE

GATE FRAME AND CENTER BRACE TO BE TO THE DIMENSIONS SHOWN ON THE DRAWING EXCEPT THAT A 3" WIDTH GATE CAN HAVE A MIN. 1" FRAME WITH NO CENTER BRACE.

GATE IS TO BE HOT DIPPED GALVANIZED OR ELECTROPLATE GALVANIZED IN ACCORDANCE WITH ASTM A-164 TYPE GS.

GATE FABRIC IS TO BE ALL #11 GAUGE EXCEPT TOP AND BOTTOM STRANDS WHICH ARE TO BE #9 VERTICAL STRANDS ARE TO BE SPACED 6" APART.

MISCELLANEOUS

IF LOCATIONS OF GATES ARE NOT SPECIFIED ON PLANS, THEY ARE TO BE ERECTED AT THE SITES DESIGNATED BY THE ENGINEER.

GATE HINGE AND LATCH ASSEMBLIES MAY BE OF ANY TYPE MEETING THE APPROVAL OF THE ENGINEER, EXCEPT THAT ALL HINGES ARE TO BE OF A BOLT-THROUGH TYPE. ALL FITTINGS ARE TO BE HOT DIPPED GALVANIZED.

ANY COMBINATION OF GATE AND FENCE TYPES MEETING THE APPROVAL OF THE ENGINEER WILL BE ACCEPTABLE AND IS NOT LIMITED TO THE EXAMPLES SHOWN HEREON.

WHERE WOOD GATES POSTS FALL IN ROCK OR MARSHY AREAS THEY ARE TO BE SET IN CLASS A3 OR C1 CONCRETE.

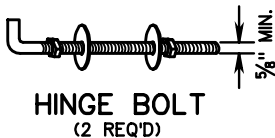

HINGE BOLT
(2 REQ'D)

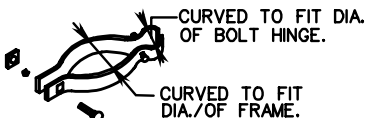

HINGE CLAMP
(2 REQ'D)

SUGGESTED HINGE ASSEMBLY

SPECIFICATION REFERENCE

242
507
236

STANDARD FENCE GATES

VIRGINIA DEPARTMENT OF TRANSPORTATION

VDOT

ROAD AND BRIDGE STANDARDS

REVISION DATE

SHEET 1 OF 1

503.05

FE-4

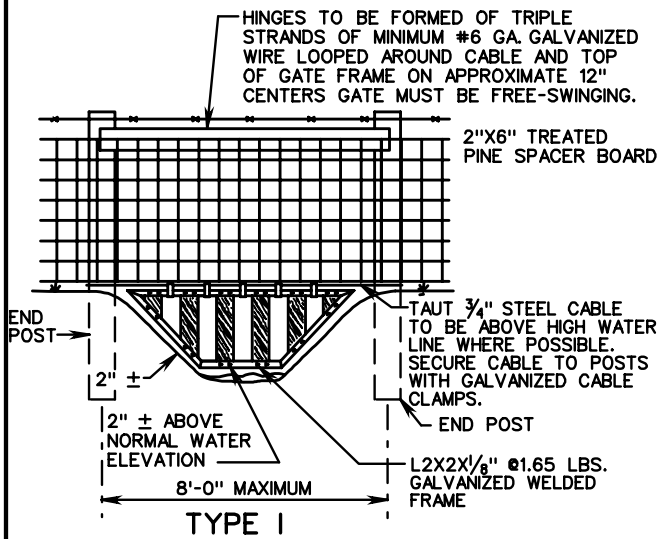

TYPE I

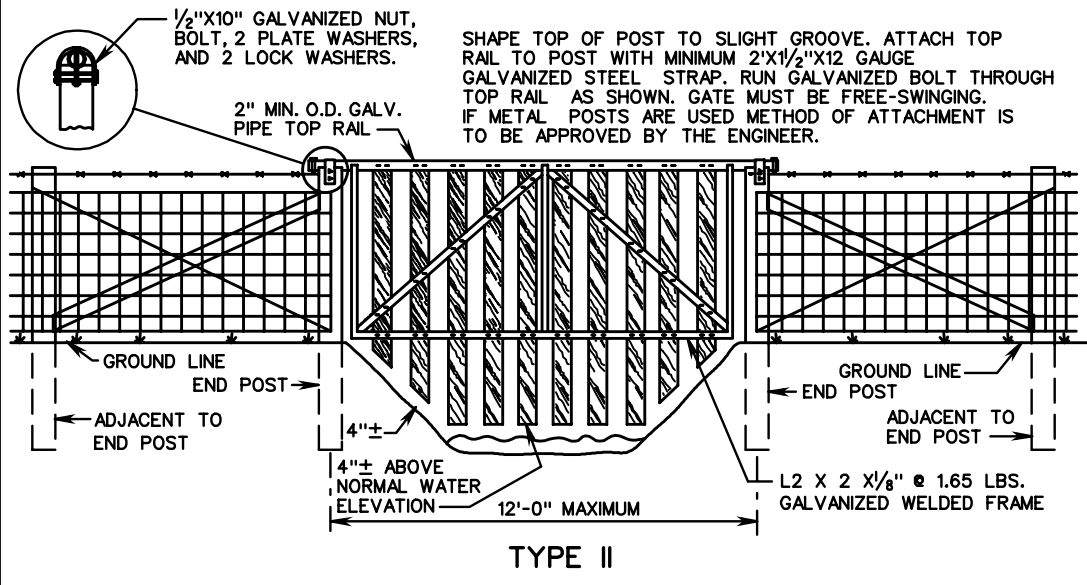

TYPE II

METHOD OF FASTENING FILLER BOARDS TO ANGLE IRON FRAME (TYPE I, TYPE II AND TYPE III)

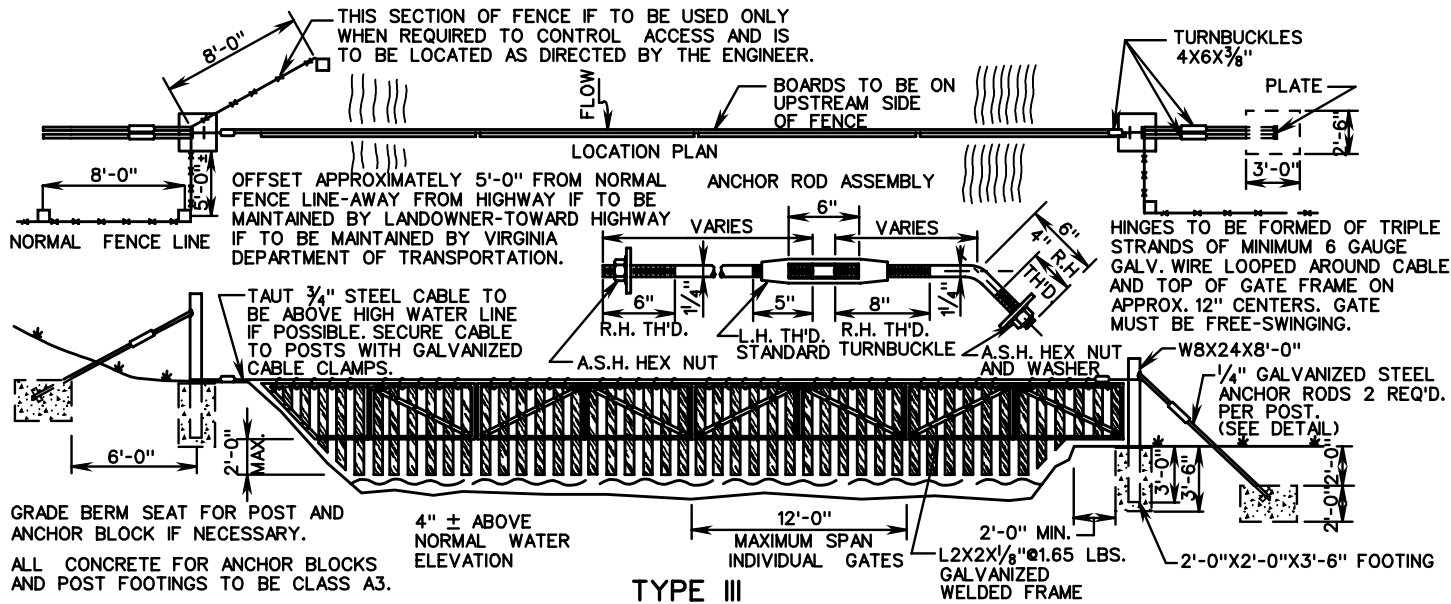
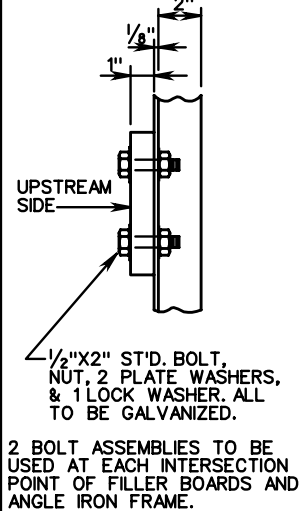

TYPE III

NOTES: WATER GATES MAY BE USED WITH STANDARD FE-W1, FE-W2 OR FE-B FENCE.
 GATE IS TO BE FABRICATED TO CONFORM TO INDIVIDUAL CHANNEL REQUIREMENTS.
 WOOD FILLER BOARDS TO BE 1" TREATED PINE BOLTED TO FRAME. SMOOTH WOOD SIDE IS TO FACE UPSTREAM.
 TYPE I GATE IS TO HAVE TWO 8" END POSTS AS SPECIFIED FOR THE TYPE OF FENCE USED. THE ADJACENT TO END POST AND BRACING MAY BE ELIMINATED.
 TYPE II GATE IS TO HAVE TWO 8" END POSTS, ADJACENT TO END POSTS, BRACING, ETC. AS SPECIFIED FOR THE TYPE OF FENCE USED.



ROAD AND BRIDGE STANDARDS

SHEET 1 OF 1

REVISION DATE

503.06

WATER GATES IN FENCE LINES

VIRGINIA DEPARTMENT OF TRANSPORTATION

SPECIFICATION REFERENCE

242
507
236

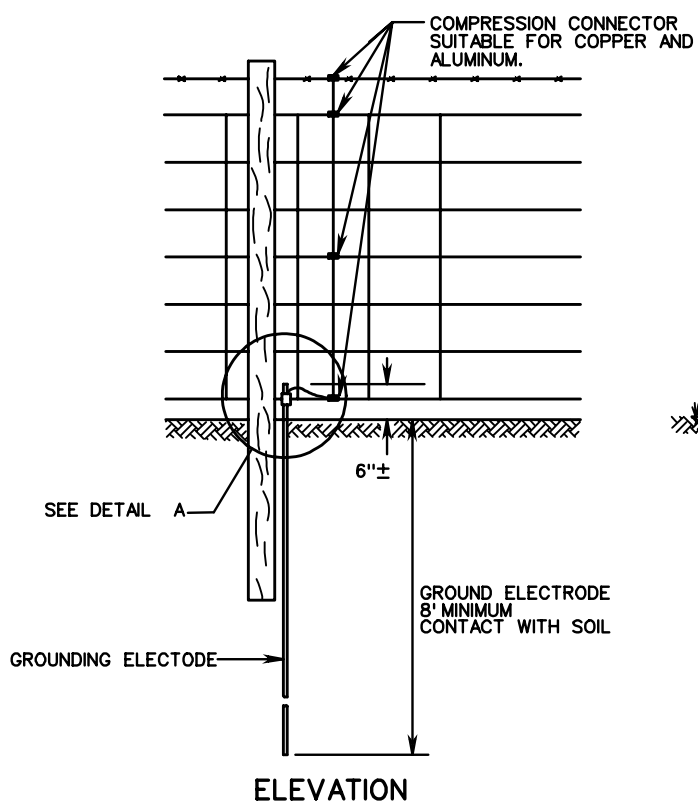

FOR CHAIN LINK FENCE GROUNDING, SEE DETAIL BELOW.

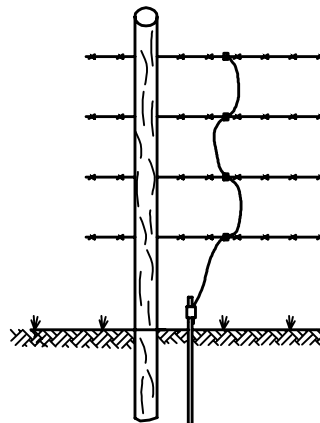

ELEVATION

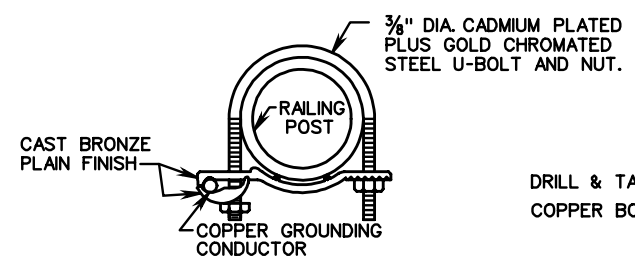

CHAIN LINK FENCE SHALL 3 CONNECTIONS FOR EACH GROUNDING CONDUCTOR/ELECTRODE: ONE CLAMP CONNECTION AT POST BASE AND TWO COMPRESSION CONNECTORS ON THE CHAIN LINK AT MIDDLE AND TOP.

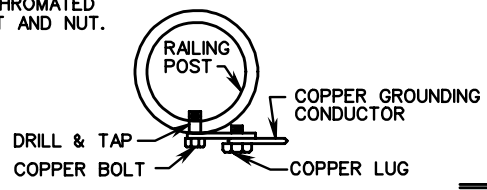

ALTERNATE

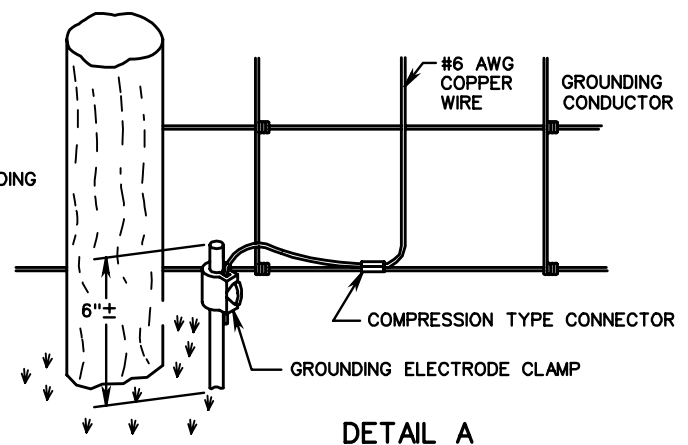

DETAIL A

NOTES:
 APPROXIMATE MATERIALS PER INSTALLATION:
 1-3/4" DIAMETER BY 10'-0" LONG COPPER CLAD GROUNDING ELECTRODE.
 1 GROUNDING ELECTRODE CLAMP
 1-7'-0" # 6 AWG SOLID COPPER CONDUCTOR
 3* COMPRESSION CONNECTORS (SUITABLE FOR COPPER AND ALUMINUM)
 * MINIMUM 3 CONNECTORS FOR 47" FENCE FABRIC TO BE SECURED TO TOP, BOTTOM AND ONE INTERMEDIATE HORIZONTAL WIRE STRAND. ONE ADDITIONAL CONNECTOR TO BE FURNISHED FOR EACH STRAND OF BARBED WIRE.
 ON BARBED WIRE INSTALLATIONS, ONE CONNECTOR IS TO BE FURNISHED FOR EACH STRAND.
 GROUNDING CONDUCTOR IS TO BE IN CONTACT WITH HORIZONTAL WIRE OF FENCE BY COMPRESSION CONNECTORS AS SHOWN.
 GROUNDING ELECTRODE TO BE LOCATED ON POST SIDE OF FENCE AND AS CLOSE AS POSSIBLE TO POST AND FENCE.
 UNLESS OTHERWISE CALLED FOR IN THE PLANS OR DIRECTED BY THE ENGINEER, FENCE GROUNDING WILL BE REQUIRED FOR METAL FENCES INCLUDING PLASTIC COATED FENCE FABRIC AT THE FOLLOWING LOCATIONS.
 -WHEN HIGH VOLTAGE LINES CROSS ABOVE THE FENCE. GROUNDING SYSTEMS SHALL BE INSTALLED 50' BEYOND THE OVERHEAD CROSSING POINT OF THE OUTER MOST CONDUCTORS OF THE HIGH VOLTAGE LINES.
 -WHEN THE HIGH VOLTAGE LINES ARE PARALLEL TO AND WITHIN 50' HORIZONTALLY OF THE FENCE. GROUNDING SYSTEMS SHALL BE INSTALLED AT 50' INTERVALS ALONG THE PARALLEL SECTIONS OF FENCE AND HIGH VOLTAGE LINES.
 COST FOR FURNISHING AND PLACING ALL GROUNDING MATERIALS IS TO BE INCLUDED IN PRICE BID PER LINEAR FOOT OF FENCE.
 DETAILS SHOWN HEREON ARE TO APPLY TO ALL METAL FENCES AND HANDRAILS. FENCES WILL BE GROUNDING ONLY WHEN INDICATED ON THE PLANS OR AS RECOMMENDED BY THE ENGINEER.

DETAIL FOR GROUNDING STEEL POST OF CHAIN LINK FENCE & HANDRAIL (HR-1)

SPECIFICATION REFERENCE 507 238	STANDARD METHOD OF FENCE & HANDRAIL GROUNDING	VDOT ROAD AND BRIDGE STANDARDS
	VIRGINIA DEPARTMENT OF TRANSPORTATION	REVISION DATE SHEET 1 OF 1 503.07

CENTER OF BACK OF MONUMENT TO BE CORRECT FOR STATION AND ALIGNMENT.

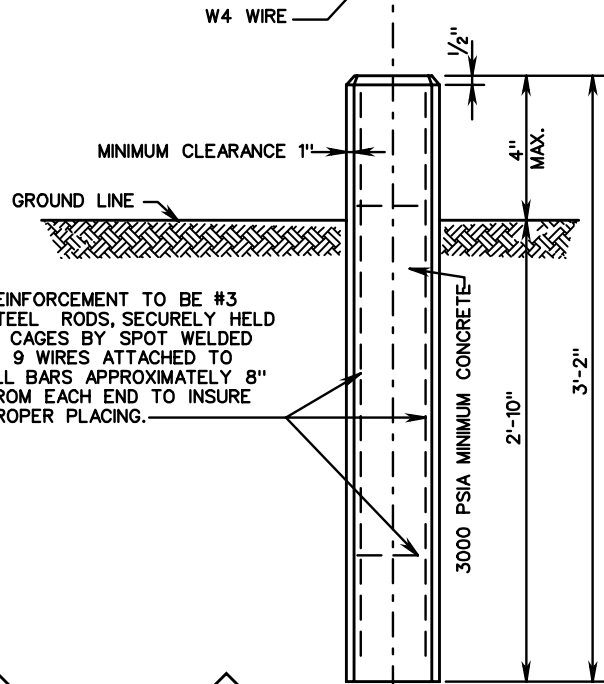
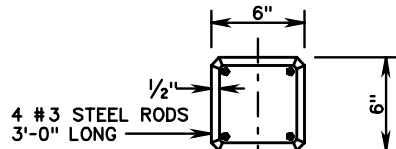

REINFORCEMENT TO BE #3 STEEL RODS, SECURELY HELD IN CAGES BY SPOT WELDED W 9 WIRES ATTACHED TO ALL BARS APPROXIMATELY 8" FROM EACH END TO INSURE PROPER PLACING.

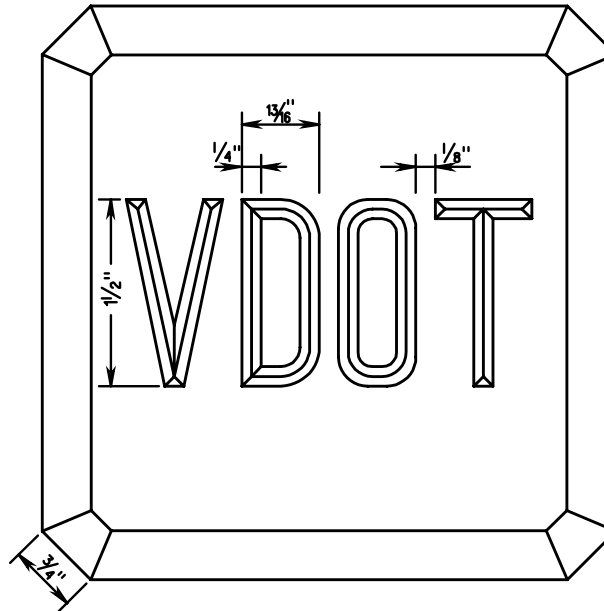

NOTES:
THE LETTERS "VDOT" ARE TO BE INDENTED IN THE TOP OF EACH RIGHT-OF-WAY MONUMENT.
IN ENTRANCES AND YARDS WHERE THE MONUMENTS WOULD BE UNSIGHTLY, THEY MAY BE SET WITH THE TOP FLUSH WITH THE GROUND.

ALTERNATE METHODS OF PLACING WIRES

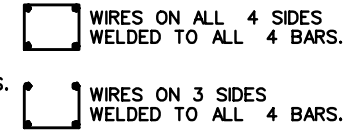

ALL LETTERING TO BE 1/2" STANDARD FOUNDRY LETTERS.

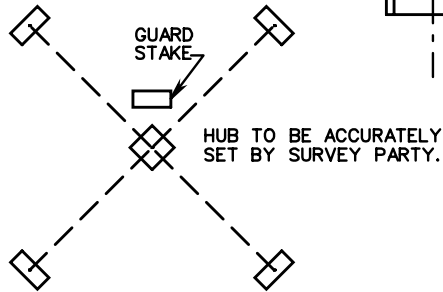

BEFORE HUB IS DISTURBED IN SETTING MONUMENTS FOUR LINER STAKES ARE TO BE SET, SO THAT TWO LINES STRETCHED BETWEEN STAKES WILL INTERSECT EXACTLY OVER TACK IN HUB. TOPS OF STAKES TO BE MORE THAN 9" ABOVE GROUND AT MONUMENT.

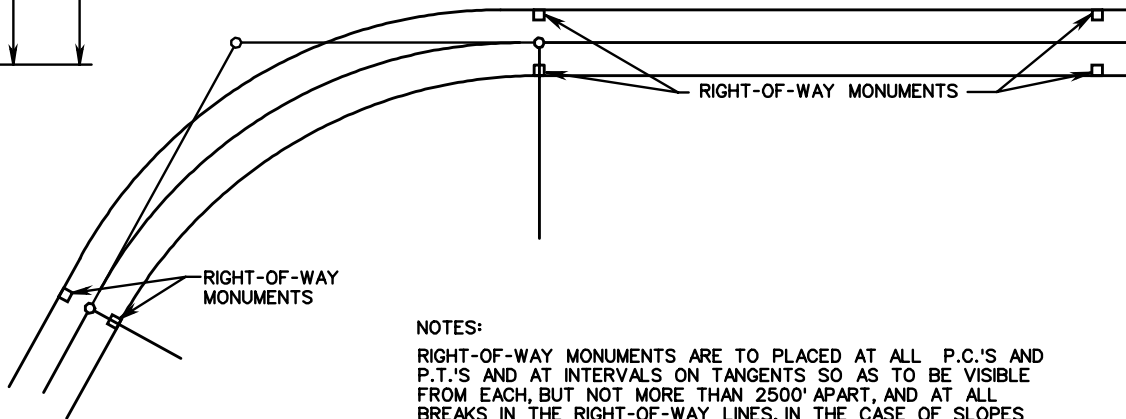

NOTES:
RIGHT-OF-WAY MONUMENTS ARE TO BE PLACED AT ALL P.C.'S AND P.T.'S AND AT INTERVALS ON TANGENTS SO AS TO BE VISIBLE FROM EACH, BUT NOT MORE THAN 2500' APART, AND AT ALL BREAKS IN THE RIGHT-OF-WAY LINES. IN THE CASE OF SLOPES ACQUIRED AS EASEMENT, THE MONUMENTS ARE TO BE SET ON NORMAL RIGHT-OF-WAY LINES.

RIGHT-OF-WAY MONUMENTS ARE TO BE SET PLUMB.



ROAD AND BRIDGE STANDARDS

SHEET 1 OF 1

REVISION DATE

504.01

STANDARD PLAN AND METHOD OF SETTING RIGHT-OF-WAY MONUMENTS

VIRGINIA DEPARTMENT OF TRANSPORTATION

SPECIFICATION REFERENCE

503

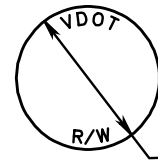
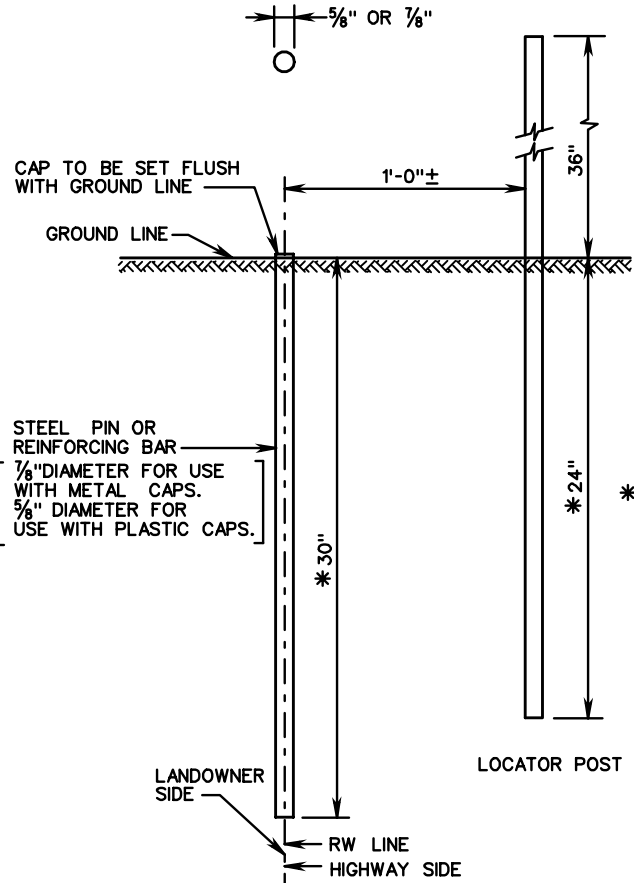

METAL CAP IS TO BE CADMIUM PLATED BRASS OR STAINLESS STEEL, SECURED WITH ROUND HEAD, DRIVE SCREW #4 X 3/16" TYPE U.

METAL CAP DETAIL

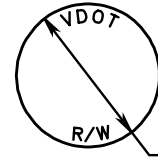

PLASTIC CAP IS TO BE HIGH VISIBILITY ORANGE WITH STAMPED, BLACK LETTERS.

PLASTIC CAP DETAIL

CAPS TO BE FURNISHED BY VDOT

* DEPTH OF PIN AND LOCATOR POST IN THE GROUND MAY BE LENGTHENED OR SHORTENED TO FIT CONDITIONS.

STEEL PIN OR REINFORCING BAR
 [7/8" DIAMETER FOR USE WITH METAL CAPS.
 5/8" DIAMETER FOR USE WITH PLASTIC CAPS.]

NOTES:

LOCATOR POST TO BE U-TYPE ROLLED RAIL STEEL @ 2 LBS./FT. OR ALUMINUM ALLOY 6063-T6 @ 0.78 LBS./FT. IN ACCORDANCE WITH THE SPECIFICATIONS.

STEEL POSTS TO BE GALVANIZED IN ACCORDANCE TO ASTM A123.

LOCATOR POST AND PIN TO BE SET BY THE SURVEY PARTY AT THE TIME OF ORIGINAL STAKING.

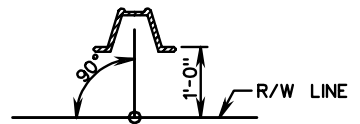

PIN TO BE ACCURATELY SET BY SURVEY PARTY AND CAP PUNCHED TO INDICATE R/W LINE.

LOCATOR POST IS TO BE ELIMINATED IN URBAN AREAS.

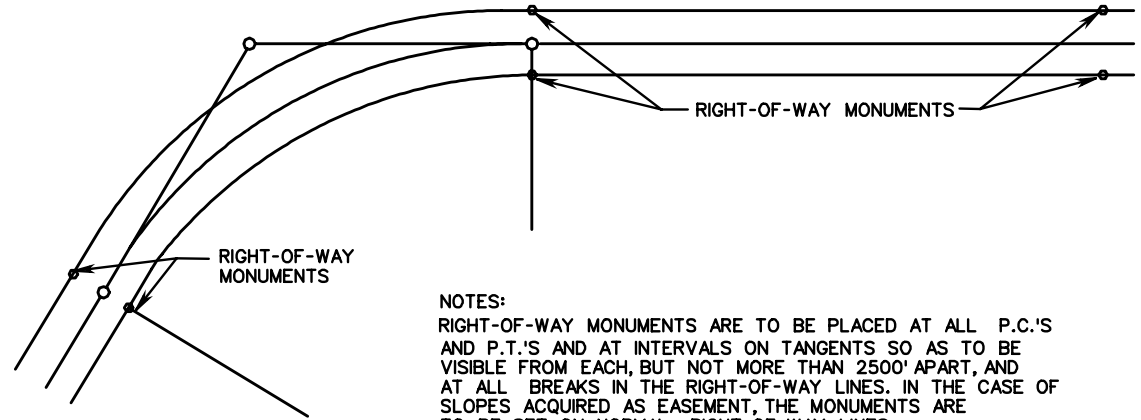

NOTES:

RIGHT-OF-WAY MONUMENTS ARE TO BE PLACED AT ALL P.C.'S AND P.T.'S AND AT INTERVALS ON TANGENTS SO AS TO BE VISIBLE FROM EACH, BUT NOT MORE THAN 2500' APART, AND AT ALL BREAKS IN THE RIGHT-OF-WAY LINES. IN THE CASE OF SLOPES ACQUIRED AS EASEMENT, THE MONUMENTS ARE TO BE SET ON NORMAL RIGHT-OF-WAY LINES.

RIGHT-OF-WAY MONUMENTS ARE TO BE SET PLUMB.

SPECIFICATION REFERENCE

219
503

STANDARD PLAN AND METHOD OF SETTING RIGHT-OF-WAY MONUMENTS

VIRGINIA DEPARTMENT OF TRANSPORTATION

VDOT

ROAD AND BRIDGE STANDARDS

REVISION DATE

SHEET 1 OF 1

504.02

THIS PAGE INTENTIONALLY LEFT BLANK



ROAD AND BRIDGE STANDARDS

SHEET 1 OF 1

REVISION DATE

504.03

VIRGINIA DEPARTMENT OF TRANSPORTATION

SPECIFICATION
REFERENCE

SECTION 600

MISCELLANEOUS DESIGNS
&
SIGHT DISTANCE TABLES

THIS PAGE INTENTIONALLY LEFT BLANK



ROAD AND BRIDGE STANDARDS

SHEET 1 OF 1

REVISION DATE

SPECIFICATION
REFERENCE

VIRGINIA DEPARTMENT OF TRANSPORTATION

STANDARD	TITLE	PAGE
S-1	STANDARD CONCRETE STEPS FOR 1½:1 SLOPES	601.01
	STANDARD CONCRETE STEPS FOR 1½:1 SLOPES	601.02
S-2	STANDARD CONCRETE STEPS FOR 2:1 SLOPES	601.03
	STANDARD CONCRETE STEPS FOR 2:1 SLOPES	601.04
HR-1	STANDARD HANDRAILS (METHOD OF LOCATING AND ERECTING)	601.05
LR-1	MINIMUM DESIGN FOR SMALL BOAT LAUNCHING RAMPS AT PUBLIC LANDINGS	601.06
SP-1	SETTLEMENT PLATE	601.07
SI-1, 2, 3	STANDARD PLAN FOR SIGN ISLANDS	602.01
PE-1	STANDARD PRIVATE ENTRANCES	602.02
CR-1	STANDARD MAINTENANCE CROSSOVER FOR USE ON FREEWAYS	602.03
RFD-1	TURN OUT DETAIL	603.01
G-3	PRECAST CONCRETE CATTLE GUARD	604.01
G-3A	PRECAST CONCRETE CATTLE GUARD	604.02
NG-1	STORAGE FACILITY FOR NUCLEAR GAUGE	605.01
RU-1	METHODS OF UNDERCUTTING ROCK	606.01
SS-1	STANDARD METHOD OF SETTING AND MARKING SLOPE STAKES	607.01
SD-1	SIGHT DISTANCES ON HORIZONTAL CURVES HEIGHT OF EYE 3.5 FEET; HEIGHT OF OBJECT 2.0 AND 3.5 FEET	608.01
SD-2	SIGHT DISTANCE ON HORIZONTAL CURVES HEIGHT OF EYE 3.5 FEET; HEIGHT OF OBJECT 0.5	608.02
	SIGHT DISTANCE ON HORIZONTAL CURVES HEIGHT OF EYE 3.5 FEET; HEIGHT OF OBJECT 0.5	608.03
SD-3	SIGHT DISTANCES ON HORIZONTAL CURVES HEIGHT OF EYE 3.5 FEET; HEIGHT OF OBJECT 4.25 FEET	608.04
	SIGHT DISTANCES ON HORIZONTAL CURVES HEIGHT OF EYE 3.5 FEET; HEIGHT OF OBJECT 4.25 FEET	608.05
SD-4	SIGHT DISTANCES ON CREST VERTICAL CURVES HEIGHT OF EYE 3.5 FEET; HEIGHT OF OBJECT 2.00 FEET	608.06
	SIGHT DISTANCES ON CREST VERTICAL CURVES HEIGHT OF EYE 3.5 FEET; HEIGHT OF OBJECT 2.00 FEET	608.07
SD-5	SIGHT DISTANCES ON CREST VERTICAL CURVES HEIGHT OF EYE 3.5 FEET; HEIGHT OF OBJECT 3.50 FEET	608.08
	SIGHT DISTANCES ON CREST VERTICAL CURVES HEIGHT OF EYE 3.5 FEET; HEIGHT OF OBJECT 3.50 FEET	608.09

INDEX OF SHEETS
SECTION 600-MISC AND TABLES

VIRGINIA DEPARTMENT OF TRANSPORTATION



ROAD AND BRIDGE STANDARDS

REVISION DATE

SHEET 1 OF 1

600.01

THIS PAGE INTENTIONALLY LEFT BLANK



ROAD AND BRIDGE STANDARDS

SHEET 1 OF 1

REVISION DATE

600.02

VIRGINIA DEPARTMENT OF TRANSPORTATION

SPECIFICATION
REFERENCE

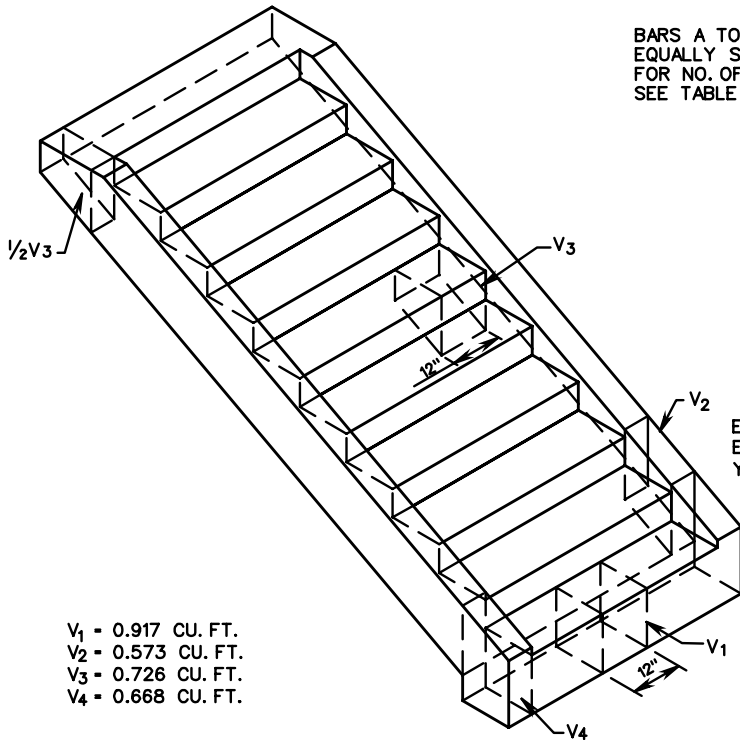

$V_1 = 0.917$ CU. FT.
 $V_2 = 0.573$ CU. FT.
 $V_3 = 0.726$ CU. FT.
 $V_4 = 0.668$ CU. FT.

FROM PICTORIAL VIEW IT IS SEEN THAT:

$$V = \frac{V_1 W + 2V_2 (N-1) + V_3 (WN+1) + 2V_4}{27}$$

SUBSTITUTING VALUES OF ELEMENTARY VOLUMES:

$$V = \frac{0.917W + 1.146(N-1) + 0.726(WN+1) + 1.336}{27}$$

V - INDICATES TOTAL VOLUME OF STEPS IN CUBIC YARDS.
 V_1, V_2, V_3 & V_4 - INDICATE ELEMENTARY VOLUMES
 USED IN COMPUTING V.

W - INDICATES CLEAR WIDTH OF STEPS, IN FEET, BETWEEN SIDEWALLS.

N - INDICATES NUMBER OF STEPS IN INSTALLATION EXCLUSIVE OF LANDING.

L1 - INDICATES LENGTH OF BARS A, IN INCHES. L1 = $13.038N + 8$ "

L2 - INDICATES LENGTH OF BARS B, IN INCHES. L2 = $12W + 9$ "

L3 - INDICATES LENGTH OF BARS C, IN INCHES. L3 = $13.038N + 18$ "

A LANDING IS TO BE PROVIDED WHERE 12 OR MORE STEPS ARE REQUIRED
 MINIMUM SIZE OF LANDING TO BE $W + 1$ FOOT X 4 FEET.

THIS ITEM MAY BE PRECAST OR CAST IN PLACE.
 CONCRETE TO BE CLASS A3 IF CAST IN PLACE, 4000 PSI IF PRECAST.

FOR OTHER WIDTHS THE APPROXIMATE SPACING OF BARS A
 IN INCHES WILL BE EQUAL TO $80 \div N$ WITH A MINIMUM SPACING OF 6".
 REINFORCING BARS TO BE USED IN INSTALLATIONS OF 6 OR MORE STEPS.
 FOR TABULATION OF CONCRETE AND STEEL QUANTITIES SEE SHEET 2.

BARS A TO BE
 EQUALLY SPACED.
 FOR NO. OF BARS
 SEE TABLE BELOW.

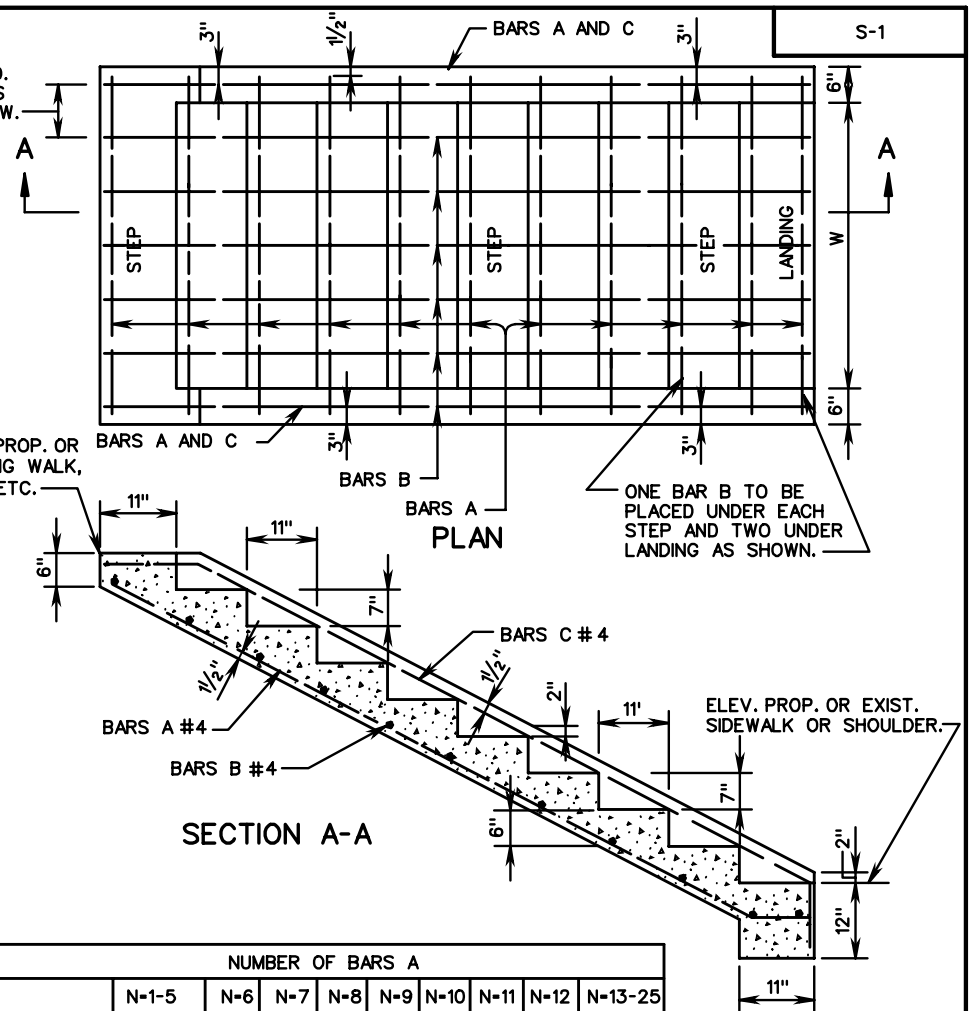

		NUMBER OF BARS A								
		N-1-5	N-6	N-7	N-8	N-9	N-10	N-11	N-12	N-13-25
W = 3'	NO STEEL	4	5	5	6	6	7	7	8	
W = 4'		5	6	7	7	8	8	9	10	
W = 5'		6	7	8	9	9	10	11	12	

HANDRAIL IS TO BE PROVIDED FOR STEPS HAVING THREE OR MORE RISERS, AND WILL MEET THE FOLLOWING CONDITIONS:

- ON STEPS LESS THAN 44 INCHES WIDE HAVING BOTH SIDES ENCLOSED, AT LEAST ONE HANDRAIL, PREFERABLY ON THE RIGHT SIDE DESCENDING.
- ON STEPS LESS THAN 44 INCHES WIDE HAVING ONE SIDE OPEN, ONE HANDRAIL ON EACH SIDE.
- ON STEPS LESS THAN 44 INCHES WIDE HAVING BOTH SIDES OPEN, ONE HANDRAIL ON EACH SIDE.
- ON STEPS MORE THAN 44 INCHES WIDE BUT LESS THAN 88 INCHES WIDE, ONE HANDRAIL ON EACH SIDE.
- ON STEPS 88 OR MORE INCHES WIDE, ONE HANDRAIL ON EACH SIDE, AND ONE INTERMEDIATE HANDRAIL LOCATED APPROXIMATELY MIDWAY OF THE WIDTH.

SPECIFICATION
 REFERENCE

105
 504

STANDARD CONCRETE STEPS FOR 1/2:1 SLOPE

VIRGINIA DEPARTMENT OF TRANSPORTATION

VDOT

ROAD AND BRIDGE STANDARDS

REVISION DATE

SHEET 1 OF 2

601.01

TABLE OF QUANTITIES

N	W = 3'		W = 4'		W = 5'		INCREMENTS *		N
	CONCRETE	REINF. STEEL	CONCRETE	REINF. STEEL	CONCRETE	REINF. STEEL	CONCRETE	REINF. STEEL	
	Cu. Yards	LBS.	Cu. Yards	LBS.	Cu. Yards	LBS.	Cu. Yards	LBS.	
1	0.259		0.320		0.381		0.061		1
2	0.382		0.470		0.558		0.088		2
3	0.505		0.620		0.734		0.115		3
4	0.628		0.770		0.911		0.142		4
5	0.751		0.920		1.088		0.168		5
6	0.874	50	1.070	60	1.265	70	0.195	10	6
7	0.998	62	1.220	74	1.442	85	0.222	12	7
8	1.121	70	1.370	89	1.619	102	0.249	13	8
9	1.244	84	1.520	99	1.796	120	0.276	14	9
10	1.367	93	1.670	116	1.973	132	0.303	16	10
11	1.490	110	1.820	127	2.150	149	0.330	17	11
12	1.613	119	1.970	146	2.326	174	0.357	19	12
13	1.736	137	2.120	167	2.503	197	0.384	30	13
14	1.859	147	2.270	179	2.680	211	0.410	32	14
15	1.983	157	2.420	191	2.857	225	0.437	34	15
16	2.106	167	2.570	203	3.034	239	0.464	36	16
17	2.229	177	2.720	215	3.211	253	0.491	38	17
18	2.352	186	2.870	227	3.388	267	0.518	40	18
19	2.476	196	3.020	239	3.565	281	0.545	43	19
20	2.598	206	3.170	251	3.742	295	0.572	45	20
21	2.721	216	3.320	262	3.918	309	0.599	47	21
22	2.844	225	3.470	274	4.095	323	0.626	49	22
23	2.967	235	3.620	286	4.272	337	0.652	51	23
24	3.091	245	3.770	298	4.449	351	0.679	53	24
25	3.214	255	3.920	310	4.626	365	0.706	55	25

* Increments to be added for each additional foot of width.

N - Indicates number of steps exclusive of landing.

W - Indicates width between sidewalks.

For detail drawings and dimensions of steps see sheet 1 of 2.



ROAD AND BRIDGE STANDARDS

SHEET 2 OF 2

REVISION DATE

601.02

STANDARD CONCRETE STEPS FOR 1 1/2:1 SLOPE

VIRGINIA DEPARTMENT OF TRANSPORTATION

SPECIFICATION
REFERENCE

105
504

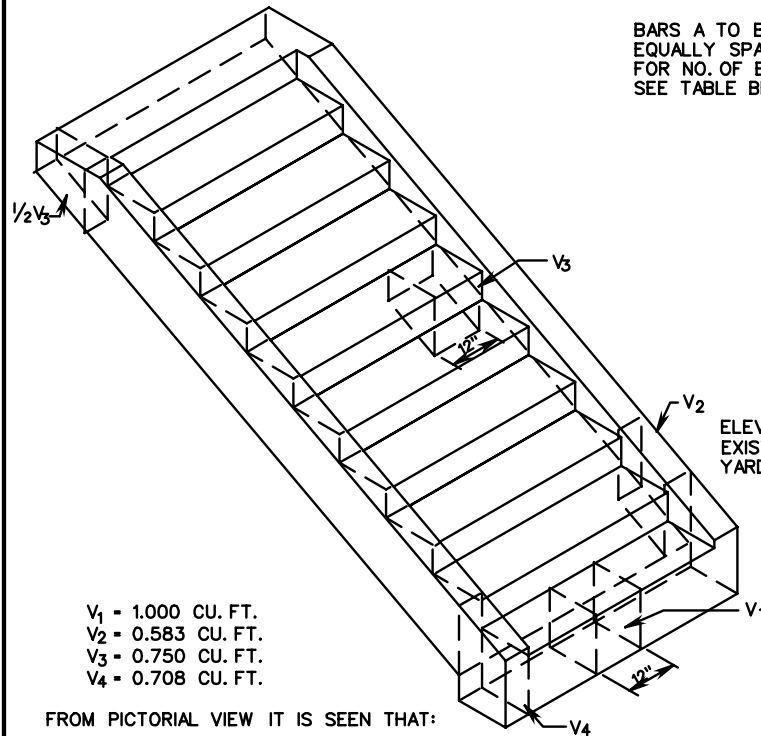

$V_1 = 1.000$ CU. FT.
 $V_2 = 0.583$ CU. FT.
 $V_3 = 0.750$ CU. FT.
 $V_4 = 0.708$ CU. FT.

FROM PICTORIAL VIEW IT IS SEEN THAT:

$$V = \frac{V_1 W + 2V_2 (N-1) + V_3 (WN+1) + 2V_4}{27}$$

SUBSTITUTING VALUES OF ELEMENTARY VOLUMES:

$$V = \frac{1.000 W + 1.166(N-1) + 0.750(WN+1) + 1.416}{27}$$

V - INDICATES TOTAL VOLUME OF STEPS IN CUBIC YARDS.

V_1, V_2, V_3 & V_4 - INDICATE ELEMENTARY VOLUMES USED IN COMPUTING V.

W - INDICATES CLEAR WIDTH OF STEPS, IN FEET, BETWEEN SIDEWALLS.

N - INDICATES NUMBER OF STEPS IN INSTALLATION EXCLUSIVE OF LANDING.

L1 - INDICATES LENGTH OF BARS A, IN INCHES. $L1 = 13.416N + 8''$

L2 - INDICATES LENGTH OF BARS B, IN INCHES. $L2 = 12W + 9''$

L3 - INDICATES LENGTH OF BARS C, IN INCHES. $L3 = 13.416N + 18''$

A LANDING IS TO BE PROVIDED WHERE 12 OR MORE STEPS ARE REQUIRED. MINIMUM SIZE OF LANDING TO BE $W + 1$ FOOT X 4 FEET.

THIS ITEM MAY BE PRECAST OR CAST IN PLACE. CONCRETE TO BE CLASS A3 IF CAST IN PLACE, 4000 PSI IF PRECAST. FOR OTHER WIDTHS THE APPROXIMATE SPACING OF BARS A IN INCHES WILL BE EQUAL TO $80/N$ WITH A MINIMUM SPACING OF 6". REINFORCING BARS TO BE USED IN INSTALLATIONS OF 6 OR MORE STEPS. FOR TABULATION OF CONCRETE AND STEEL QUANTITIES SEE SHEET 2.

BARS A TO BE EQUALLY SPACED. FOR NO. OF BARS SEE TABLE BELOW.

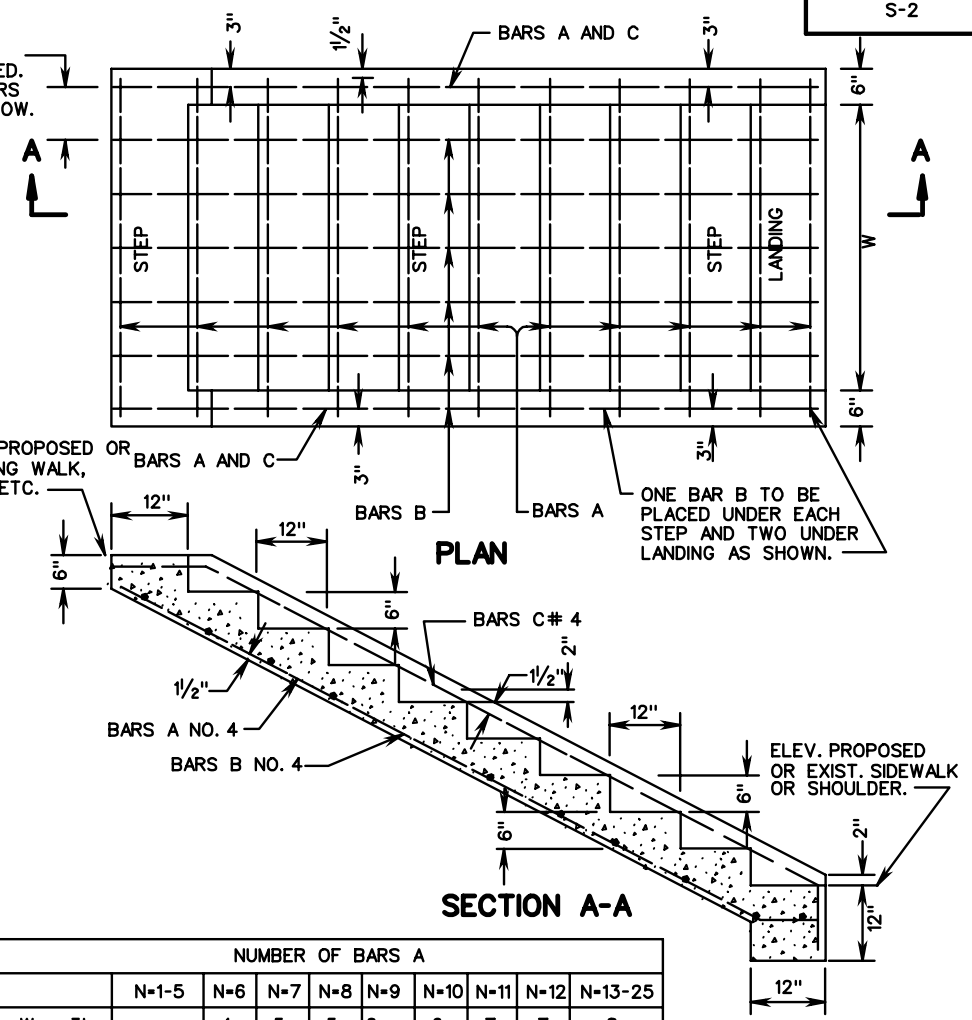

PLAN

SECTION A-A

		NUMBER OF BARS A								
		N=1-5	N=6	N=7	N=8	N=9	N=10	N=11	N=12	N=13-25
W - 3'	NO STEEL	4	5	5	6	6	7	7	8	
		5	6	7	7	8	8	9	10	
		6	7	8	9	9	10	11	12	

HANDRAIL IS TO BE PROVIDED FOR STEPS HAVING THREE OR MORE RISERS, AND WILL MEET THE FOLLOWING CONDITIONS:

- ON STEPS LESS THAN 44 INCHES WIDE HAVING BOTH SIDES ENCLOSED, AT LEAST ONE HANDRAIL, PREFERABLY ON THE RIGHT SIDE DESCENDING.
- ON STEPS LESS THAN 44 INCHES WIDE HAVING ONE SIDE OPEN, ONE HANDRAIL ON EACH SIDE.
- ON STEPS LESS THAN 44 INCHES WIDE HAVING BOTH SIDES OPEN, ONE HANDRAIL ON EACH SIDE.
- ON STEPS MORE THAN 44 INCHES WIDE BUT LESS THAN 88 INCHES WIDE, ONE HANDRAIL ON EACH SIDE.
- ON STEPS 88 OR MORE INCHES WIDE, ONE HANDRAIL ON EACH SIDE, AND ONE INTERMEDIATE HANDRAIL LOCATED APPROXIMATELY MIDWAY OF THE WIDTH.

SPECIFICATION REFERENCE
105 504

STANDARD CONCRETE STEPS FOR 2:1 SLOPE

VIRGINIA DEPARTMENT OF TRANSPORTATION

VDOT	
ROAD AND BRIDGE STANDARDS	
REVISION DATE	SHEET 1 OF 2
601.03	

TABLE OF QUANTITIES

N	W - 3'		W - 4'		W - 5'		INCREMENTS *		N
	CONCRETE	REINF. STEEL	CONCRETE	REINF. STEEL	CONCRETE	REINF. STEEL	CONCRETE	REINF. STEEL	
	CU. YARDS	LBS.	CU. YARDS	LBS.	CU. YARDS	LBS.	CU. YARDS	LBS.	
1	0.275		0.340		0.405		0.065		1
2	0.401		0.494		0.587		0.093		2
3	0.528		0.648		0.768		0.120		3
4	0.654		0.802		0.950		0.148		4
5	0.781		0.957		1.133		0.176		5
6	0.907	51	1.111	61	1.315	71	0.204	10	6
7	1.034	63	1.265	75	1.496	87	0.231	12	7
8	1.160	71	1.419	91	1.678	104	0.259	13	8
9	1.287	86	1.574	101	1.861	122	0.287	15	9
10	1.413	94	1.728	118	2.043	134	0.315	16	10
11	1.540	112	1.883	129	2.226	155	0.343	17	11
12	1.666	121	2.036	149	2.406	177	0.370	19	12
13	1.793	140	2.191	171	2.589	201	0.398	30	13
14	1.919	150	2.345	183	2.771	215	0.426	32	14
15	2.046	160	2.500	195	2.954	229	0.454	35	15
16	2.172	170	2.653	207	3.134	244	0.481	37	16
17	2.299	180	2.808	219	3.317	258	0.509	39	17
18	2.425	190	2.962	231	3.499	272	0.537	41	18
19	2.552	200	3.117	243	3.682	287	0.565	43	19
20	2.678	210	3.271	256	3.864	301	0.593	45	20
21	2.805	220	3.425	268	4.045	315	0.620	48	21
22	2.931	230	3.579	280	4.227	330	0.648	50	22
23	3.058	240	3.734	292	4.410	344	0.676	52	23
24	3.184	250	3.888	304	4.592	358	0.704	54	24
25	3.311	260	4.042	316	4.773	372	0.731	56	25

* Increments to be added for each additional foot of width.

N - Indicates number of steps exclusive of landing.

W - Indicates width between sidewalls.

For detail drawings and dimensions of steps see sheet 1.



ROAD AND BRIDGE STANDARDS

SHEET 2 OF 2

REVISION DATE

601.04

STANDARD CONCRETE STEPS FOR 2:1 SLOPE

VIRGINIA DEPARTMENT OF TRANSPORTATION

SPECIFICATION
REFERENCE

105
504

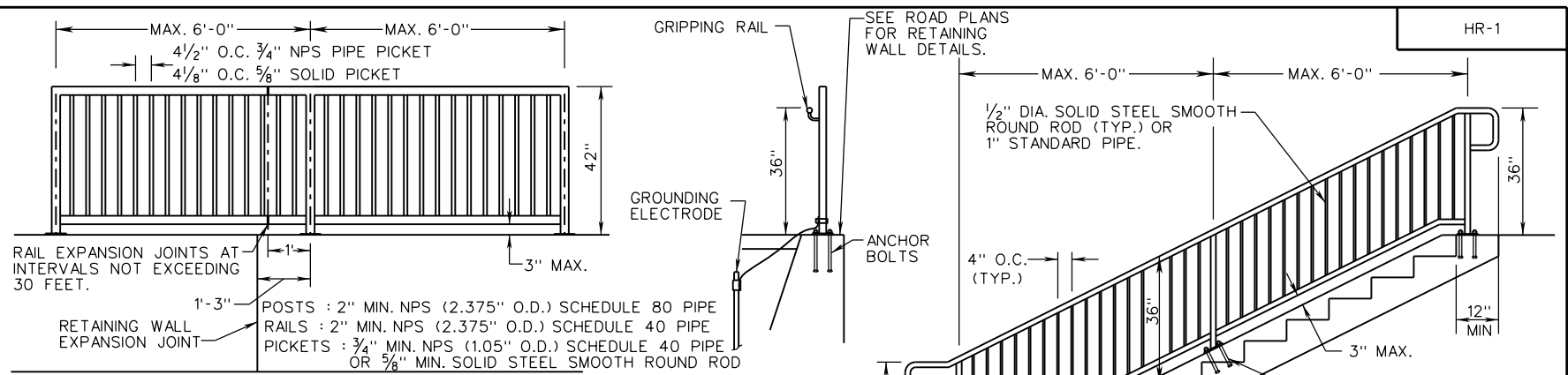

HR-1 TYPE II PEDESTRIAN RAILING
(FOR USE ALONG SIDEWALKS AND RAMPS)

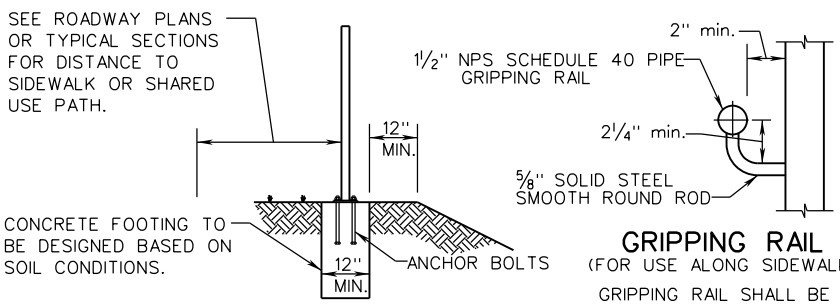

GRIPPING RAIL DETAIL
(FOR USE ALONG SIDEWALKS AND RAMPS)

EARTH FOUNDATION DETAIL
(FOR USE WITH TYPE II & III RAILINGS)

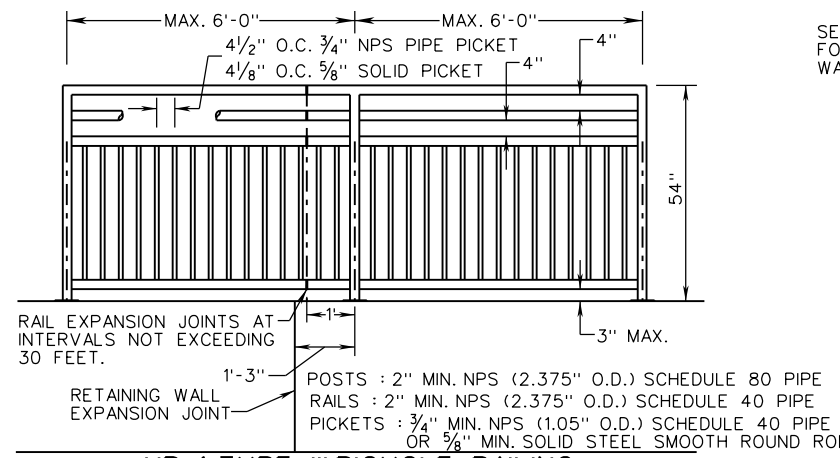

HR-1 TYPE III BICYCLE RAILING
(FOR USE ALONG SHARED USE PATHS)

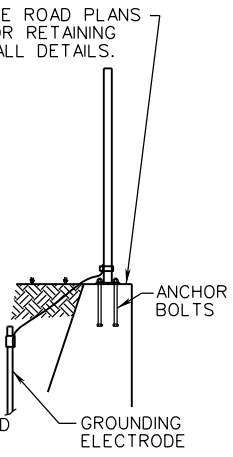

NOTES

1. THE CONTRACTOR SHALL SUBMIT DRAWINGS DETAILING ALL ASPECTS OF FABRICATION AND INSTALLATION OF RAILING, INCLUDING CONCRETE FOUNDATIONS FOR APPROVAL BY THE ENGINEER PRIOR TO INSTALLATION. SHOP DRAWINGS SHALL BE SIGNED AND SEALED BY A PROFESSIONAL ENGINEER, HOLDING A VALID LICENSE TO PRACTICE ENGINEERING IN THE COMMONWEALTH OF VIRGINIA.
2. ALL RAILING COMPONENTS AND FASTENERS SHALL BE GALVANIZED IN ACCORDANCE WITH THE CURRENT ROAD AND BRIDGE SPECIFICATIONS. TO ACHIEVE A UNIFORM COATING ON ALL SURFACES VENTING AND DRAINAGE HOLES FOR GALVANIZING SHALL BE INCLUDED IN THE SHOP DRAWINGS.
3. ALL FASTENERS SHALL BE IN ACCORDANCE WITH ASTM A307, ASTM A563, AND ASTM F844. ALL ANCHOR BOLTS SHALL BE IN ACCORDANCE WITH AASHTO M314, GRADE 36.
4. A CHEMICAL ANCHOR SYSTEM FROM VDOT'S APPROVED MATERIAL LIST MAY BE USED IN LIEU OF CAST IN PLACE ANCHORS AND SHALL BE INCLUDED IN THE SHOP DRAWINGS.
5. POSTS SHALL BE MITERED TO MATCH GRADE OF RAMPS, SIDEWALKS, AND STEPS.
6. HANDRAILS SHALL MATCH GRADE OF RAMPS SIDEWALKS AND STEPS.
7. ALL POSTS AND PICKETS SHALL BE SET PLUMB.
8. RAILINGS SHALL BE GROUNDED AND EFFECTIVELY BONDED. GROUNDING MATERIALS INSTALLATION TO BE IN ACCORDANCE WITH ST'D. FE-6.
9. COMMERCIALY AVAILABLE RAILING SYSTEMS MAY BE USED IN LIEU OF DESIGNING AND FABRICATING THE RAILING. DOCUMENTATION FROM THE MANUFACTURER VERIFYING THAT PROJECT REQUIREMENTS ARE MET WITH THE RAILING SYSTEM SHALL BE SUBMITTED WITH THE INSTALLATION DRAWINGS AND APPROVED BY THE ENGINEER IN ACCORDANCE WITH NOTE 1.
10. HANDRAIL TO BE IN ACCORDANCE WITH THE LATEST EDITION OF THE VIRGINIA UNIFORM STATEWIDE BUILDING CODE.
11. THIS HANDRAIL IS TO BE USED ONLY AS A PROTECTION FOR PEDESTRIANS AND SHOULD NOT BE PLACED IN ANY LOCATION WHERE IT MIGHT BE SUBJECT TO ANY VEHICULAR IMPACT. FOR VEHICULAR PROTECTION STANDARD GUARDRAIL SHOULD BE USED.

SPECIFICATION REFERENCE
105
238
504

A COPY OF THE ORIGINAL SEALED AND SIGNED DRAWING IS ON FILE IN THE CENTRAL OFFICE.

STANDARD HANDRAIL
METHOD OF LOCATING AND ERECTING
VIRGINIA DEPARTMENT OF TRANSPORTATION

VDOT	
ROAD AND BRIDGE STANDARDS	
REVISION DATE	SHEET 1 OF 1
7/11	601.05

NOTES:

1. THE MINIMUM SLAB WIDTH IS TO BE 16'.
2. SLAB DETAILS ARE TO BE IN ACCORDANCE WITH STANDARD PLAN PR-2 EXCEPT THAT EXPANSION, CONTRACTION, AND LONGITUDINAL JOINTS MAY BE ELIMINATED UNLESS REQUIRED BY THE ENGINEER.
3. STEEL FABRIC SLAB REINFORCEMENT SHALL CONSIST OF MEMBERS RIGIDLY ATTACHED AT ALL JOINTS OR POINTS OF INTERSECTION AND SHALL HAVE AN EFFECTIVE WEIGHT OF NOT LESS THAN 61 LBS./100 SQ.FT. LONGITUDINAL MEMBERS SHALL BE OF NO. 1 GAGE WIRE SPACED AT 6" O-C. TRANSVERSE MEMBERS SHALL BE OF NO. 4 GAGE WIRE SPACED AT 12" O-C. ALTERNATE GRADE 60 NO. 4 REBARS 12" O-C EACHWAY CENTERED IN SLAB.
4. SLAB IS TO BE CONSTRUCTED ON EITHER A STRAIGHT GRADE OR WITH VERTICAL CURVES WITH A RATE OF CHANGE PER FOOT OF LESS THAN 2%.
5. THE GRADIENT OF SLAB IS TO BE 12-15%. RAMPS CONSTRUCTED IN SALT WATER WITH THE POSSIBILITY OF LARGER BOATS USING THE RAMP SHOULD BE DESIGNED USING THE LOWER END OF THIS RANGE.
6. ALL REINFORCING STEEL MEMBERS ARE TO HAVE A MINIMUM OF 3" CONCRETE COVER AT EDGES OF SLAB. MESH REINFORCEMENT IS TO BE PLACED 2" FROM TOP OF SLAB.
7. FINAL FINISH OF SLAB IS TO BE OBTAINED BY THE USE OF A STEEL RAKE (WITH TINES BENT AWAY FROM THE DIRECTION OF PULL) DRAWN TRANSVERSLY TO AXIS OF SLAB (PARALLEL TO WATER LINE).
8. PORTIONS OF SLAB WHICH WILL ULTIMATELY BE BELOW WATER LEVEL ARE TO BE PROTECTED DURING POURING, FINISHING, AND CURING BY THE USE OF COFFERDAMS, CRIBS, OR OTHER METHODS MEETING THE APPROVAL OF THE ENGINEER.
9. CLASS 1 DRY RIP RAP TO BE IN ACCORDANCE WITH ROAD AND BRIDGE SPECIFICATIONS.
10. SUITABLE PARKING AREAS FOR VEHICLES AND TRAILER ARE TO BE PROVIDED OFF OF RAMP.
11. RAMP SHOULD BE ANGLED DOWNSTREAM IN RIVER SITUATIONS AT THE DISCRETION OF THE ENGINEER.
12. ON FLOWING RIVER SITUATIONS COURTESY PIERS ARE NOT DESIRABLE, ON ALL OTHER SITUATIONS A COURTESY PIER IS DESIRABLE.
13. LAUNCH RAMPS AND PARKING AREAS SHOULD BE FREE OF OVERHEAD OBSTRUCTIONS, ESPECIALLY ELECTRICAL WIRES.
14. THESE FACILITIES SHOULD BE HANDICAPPED ACCESSIBLE TO THE TOP OF BOAT RAMP AND COURTESY PIER IF PROVIDED.
15. WHERE WAVE OR TIDAL ACTION OCCUR, THE RIP RAP LENGTH ABOVE MEAN HIGH WATER SHALL BE EXTENDED TO DISSIPATE WATER VELOCITIES.

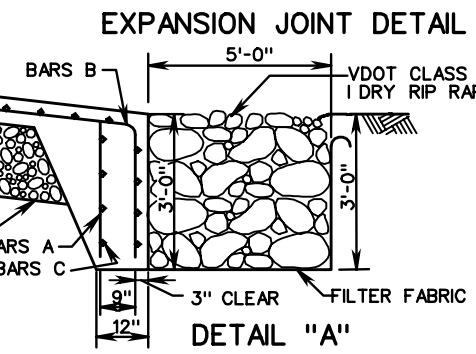
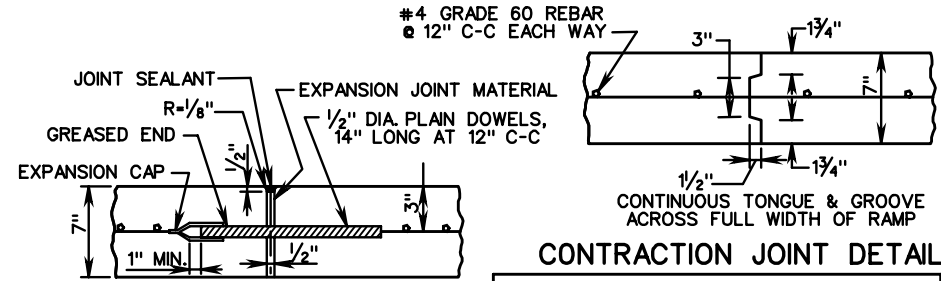
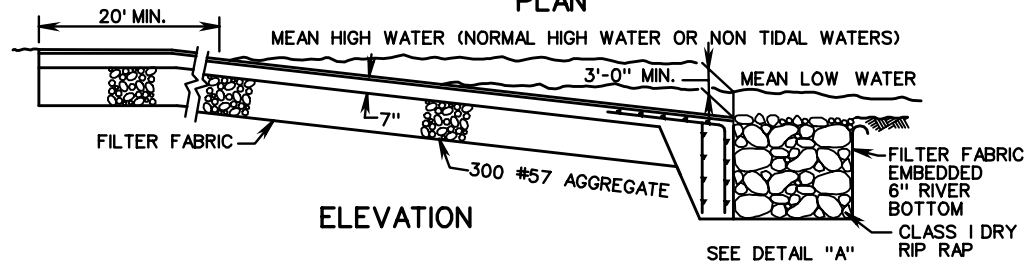
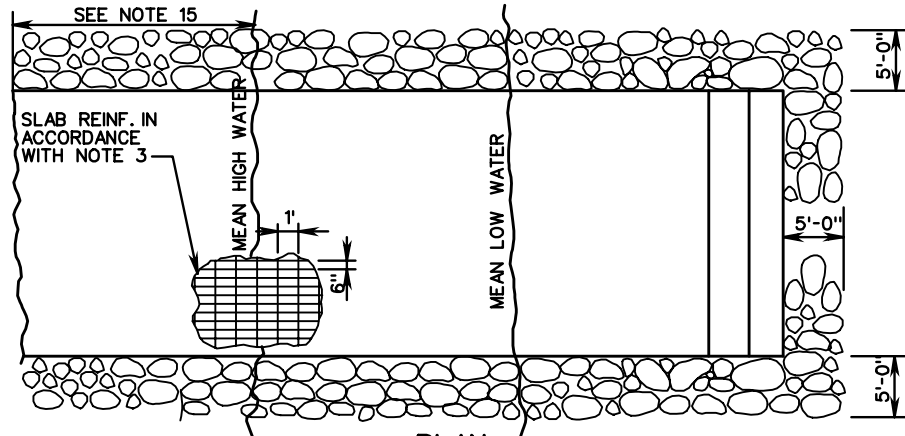

CONTRACTION JOINT DETAIL

CONTINUOUS TONGUE & GROOVE ACROSS FULL WIDTH OF RAMP

SCHEDULE OF REINFORCING STEEL					
		2'-8"		1'-10"	
BEND TO FIT GRADE BARS "B"					
BAR	SIZE	NO.	LENGTH	SPACING C-C	
A	# 4	*	2'-0"	1'-0"	STRAIGHT
B	# 4	*	4'-6"	1'-0"	BENT
C	# 4	8	* *	9" AND AS SHOWN	STRAIGHT
* NO. OF BARS EQUALS SLAB WIDTH IN FEET.					
** SLAB WIDTH MINUS 6"					

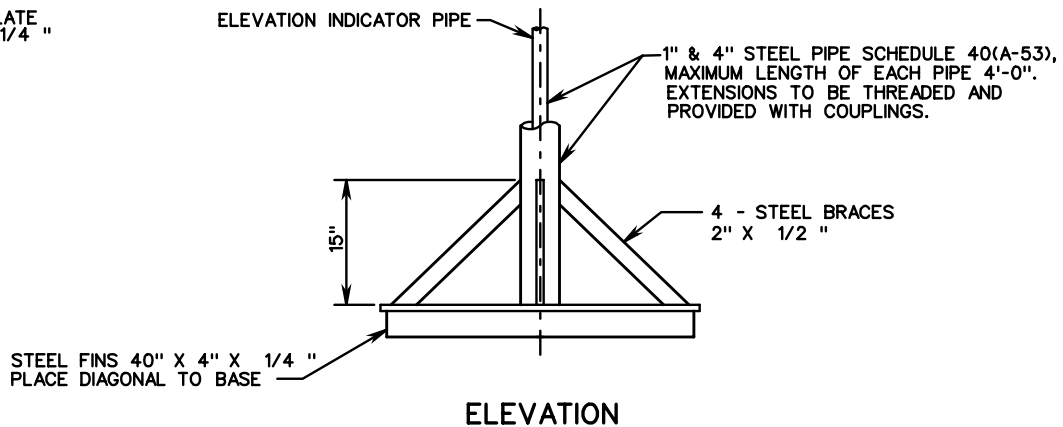
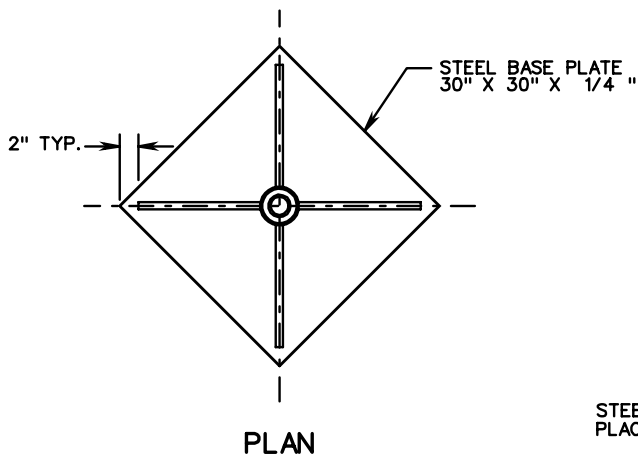

NOTE:
SETTLEMENT PLATES ARE TO BE PLACED AS SHOWN ON PLANS
OR AS DIRECTED BY THE ENGINEER.

ALL CONNECTIONS BETWEEN BASE PLATE, PIPES, FINS AND
BRACES ARE TO BE FULLY WELDED.

SPECIFICATION REFERENCE	<h2 style="margin: 0;">SETTLEMENT PLATE</h2> <p style="margin: 0;">VIRGINIA DEPARTMENT OF TRANSPORTATION</p>	<p style="margin: 0;">ROAD AND BRIDGE STANDARDS</p>	
303.10		REVISION DATE	SHEET 1 OF 1
			601.07

SI-1

NOTE:
 C OF ISLAND IS TO BE PERPENDICULAR TO C OF MAJOR ROUTE REGARDLESS OF THE ANGLE OF INTERSECTION.

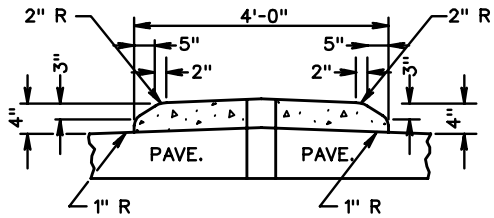

SECTION A-A

BASIS OF PAYMENT - EACH

0.5 CU. YDS CONCRETE TO BE CLASS A3 IF CAST IN PLACE, 4000 PSI IF PRECAST.

NOTE:
 SIZE OF ISLAND IS TO BE GOVERNED BY OFFSETS FROM PAVEMENT EDGES & C AS SHOWN ON PLANS.

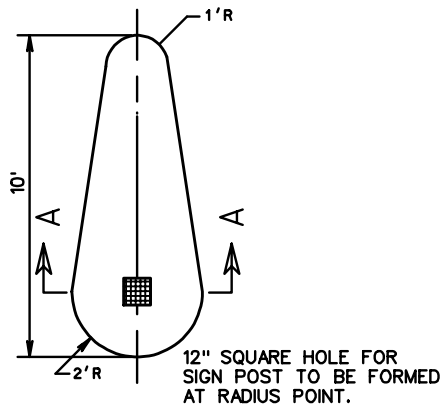

WHEN SIGN ISLAND IS INSTALLED OVER EXISTING PAVEMENT A HOLE FOR SIGN POST IS TO BE EXTENDED TO THE SUBBASE.

DETAIL OF STANDARD SIGN ISLAND

SI-2

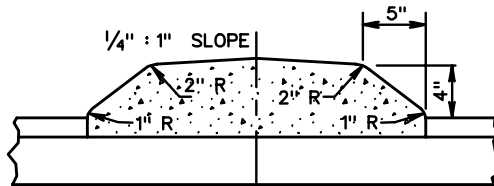

BASIS OF PAYMENT - SQUARE YARDS COMPLETE IN PLACE EXCLUSIVE OF POST AND SIGNS

NOTE:
 SIZE OF ISLAND IS TO BE GOVERNED BY OFFSETS FROM PAVEMENT EDGES & C AS SHOWN ON PLANS.

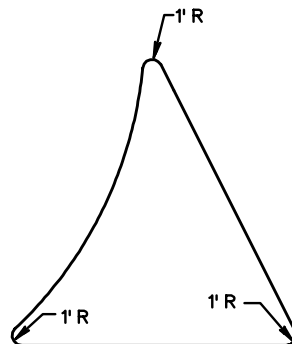
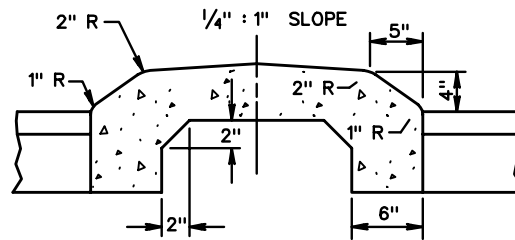

DESIGN OF STANDARD SIGN ISLAND

SI-3

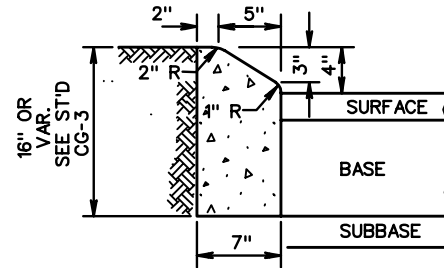

NOTE:

SIZE OF ISLAND IS TO BE GOVERNED BY OFFSETS FROM PAVEMENT EDGES & C AS SHOWN ON PLANS.

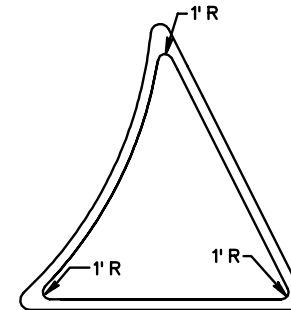

DETAIL OF DIRECTIONAL ISLAND CURB



ROAD AND BRIDGE STANDARDS

STANDARD PLAN FOR SIGN ISLANDS

SPECIFICATION REFERENCE

SHEET 1 OF 1

REVISION DATE

105
502

602.01

VIRGINIA DEPARTMENT OF TRANSPORTATION

* TO BE DETERMINED BY THE EXISTING CONDITIONS AT THE TIME OF CONSTRUCTION

- TYPE I - CRUSHER RUN AGGREGATE
- TYPE II - CONCRETE
- TYPE III - ASPHALT
- TYPE IV - ASPHALT COMMERCIAL

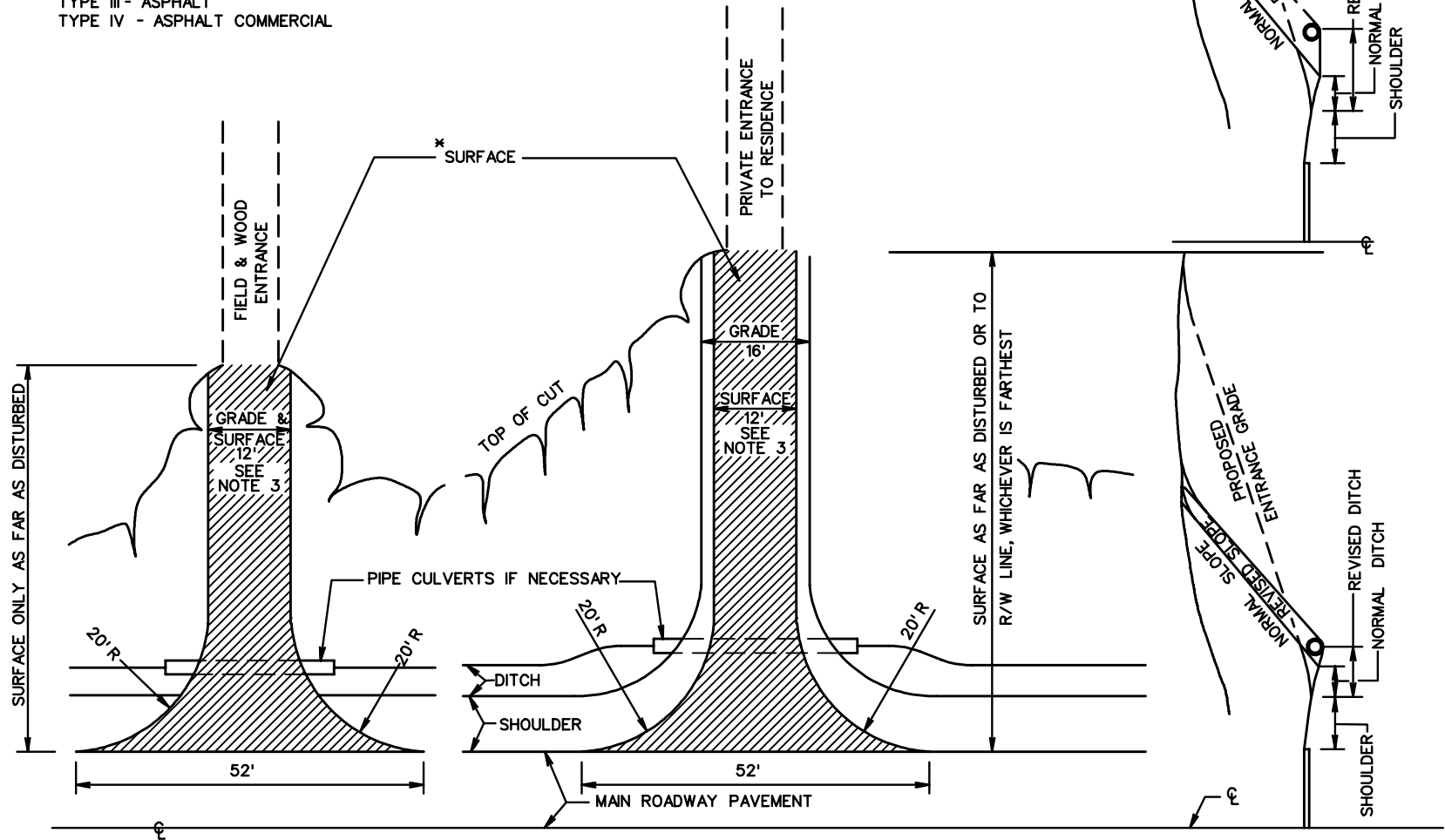

NOTES:

1. ALL ENTRANCE GRADES SHALL START BACK OF THE SHOULDER LINE. IF DRAINAGE IS NECESSARY, THE DITCH MAY BE MOVED BACK TO PROVIDE AT LEAST 9" OF COVER OVER PIPE, AS SHOWN IN THE ALTERNATE METHODS FOR PLACING PIPE UNDER ENTRANCES DIAGRAM.
2. ENTRANCE GRADES ARE TO BE SMOOTHLY TIED INTO THE ROADWAY BY ROUNDING AS NECESSARY.
3. 12' OR EXISTING WIDTH WHICHEVER IS GREATER.
4. LENGTHS OF CULVERTS SHOWN ON ROAD PLANS FOR ENTRANCES ARE APPROXIMATE AND SHALL BE ADJUSTED TO OBTAIN ABOVE ROADWAY WIDTHS.
5. ENTRANCES IN FILL TO BE SAME AS ABOVE EXCEPT LOCATION OF CULVERT (WHEN NECESSARY).

ALTERNATE METHODS FOR PLACING PIPES UNDER ENTRANCES

SPECIFICATION REFERENCE	<h1>STANDARD PRIVATE ENTRANCES</h1>	VDOT ROAD AND BRIDGE STANDARDS	
512	VIRGINIA DEPARTMENT OF TRANSPORTATION	REVISION DATE	SHEET 1 OF 1
			602.02

EXAMPLES OF ALTERNATE MEDIAN DRAINAGE

THESE ALTERNATIVES COULD BE CONSIDERED IN LIEU OF A PIPE UNDERNEATH THE MEDIAN CROSSOVER.

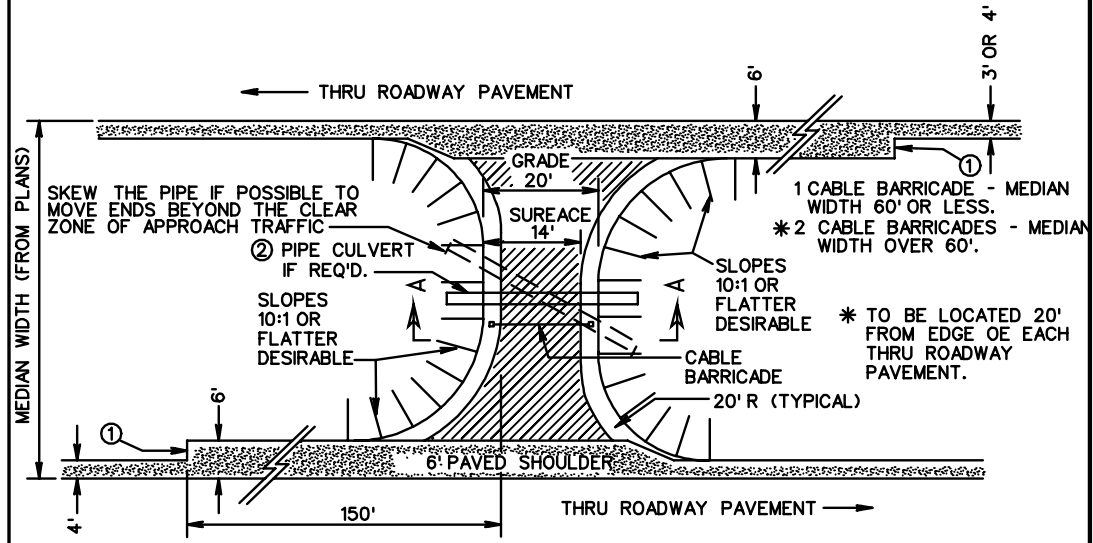
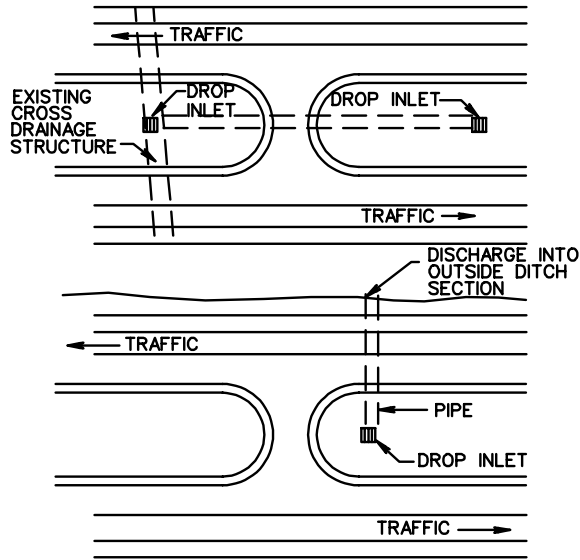

PLAN

- ① WIDEN PAVED PORTION OF MEDIAN SHOULDER OR 150' TO ACCOMMODATE TURNING VEHICLES.
- ② END TREATMENT AS REQUIRED TO MEET PROPOSED SLOPE.

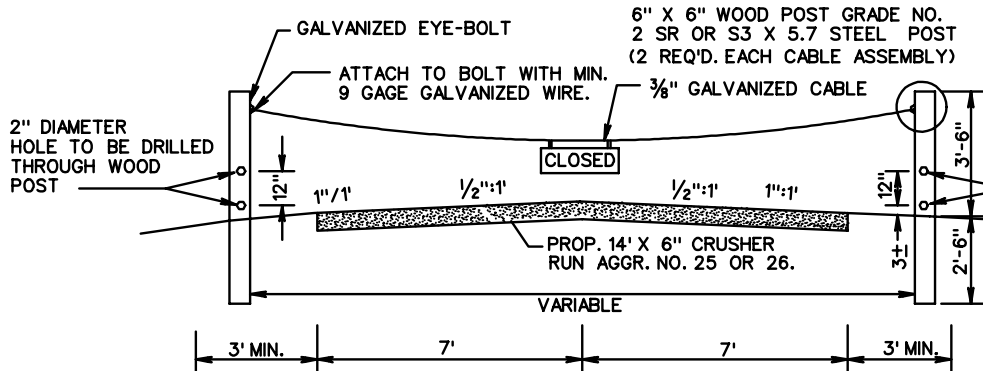

SECTION A-A

WOOD POSTS TO BE SALT TREATED OR PRIMED AND PAINTED DARK GREEN.

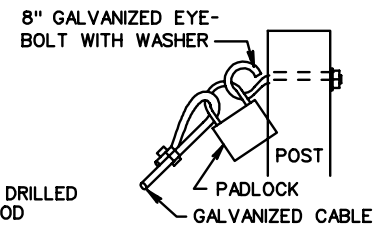

PADLOCK TO BE FURNISHED AND INSTALLED BY STATE FORCES UNLESS OTHERWISE SPECIFIED. CONTRACTOR TO TEMPORARILY ATTACH CABLE TO EYE-BOLT WITH MINIMUM 9 GAUGE GALVANIZED WIRE.

**** SIGN**
 MATERIAL: 0.080" ALUMINUM ALLOY 6061 - T6
 SIZE : 24" X 9"
 COLOR COMBINATION : C-1
 BORDER WIDTH : 1/2"
 MARGIN WIDTH : 1/2"
 CORNER RADII : 1/2"
 LETTER TYPE : L-1 OR L-2
 LETTER HEIGHT AND SERIES : 4" - D
***** IN ACCORDANCE WITH V.D.O.T. "MANUAL OF UNIFORM TRAFFIC CONTROL DEVICES FOR STREETS AND HIGHWAYS".**
**** MESSAGE, BOTH SIDES IF ONE CABLE BARRICADE IS USED. MESSAGE, ONE SIDE IF TWO CABLE BARRICADES ARE USED.**



ROAD AND BRIDGE STANDARDS

SHEET 1 OF 1

REVISION DATE

602.03

STANDARD MAINTENANCE CROSSOVER FOR USE ON FREEWAYS

VIRGINIA DEPARTMENT OF TRANSPORTATION

SPECIFICATION REFERENCE

505

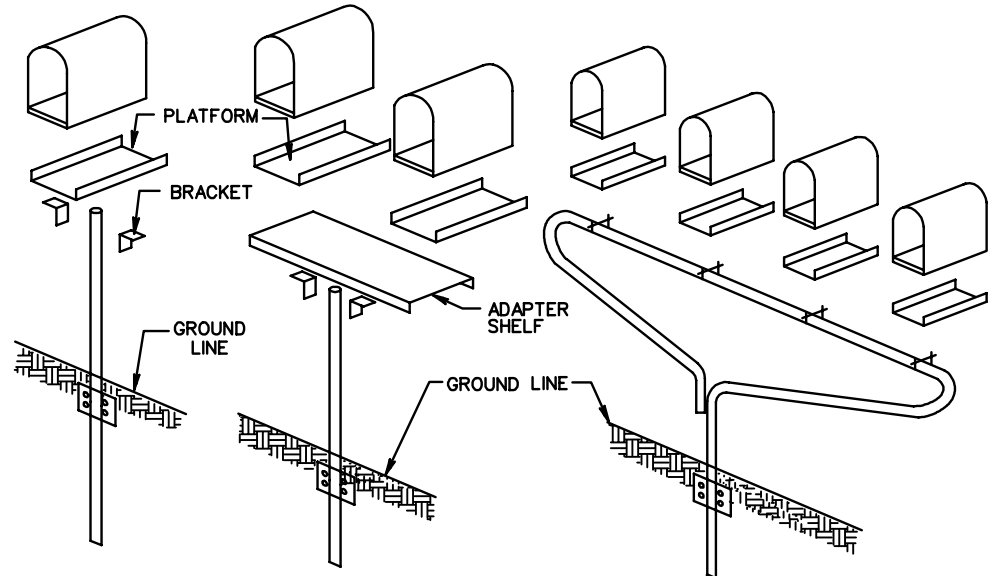

SINGLE

DOUBLE

MULTIPLE
(MAX. 4 BOXES)

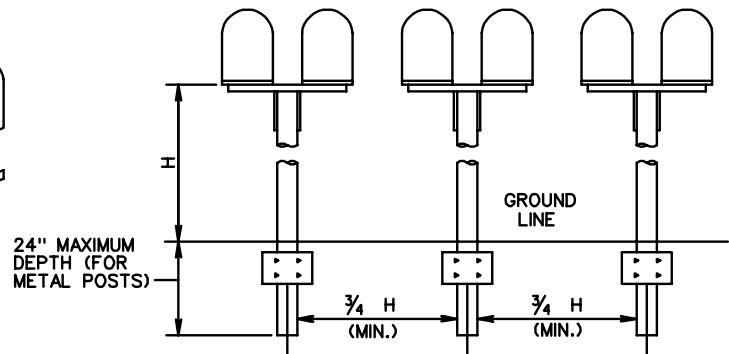

GROUPED

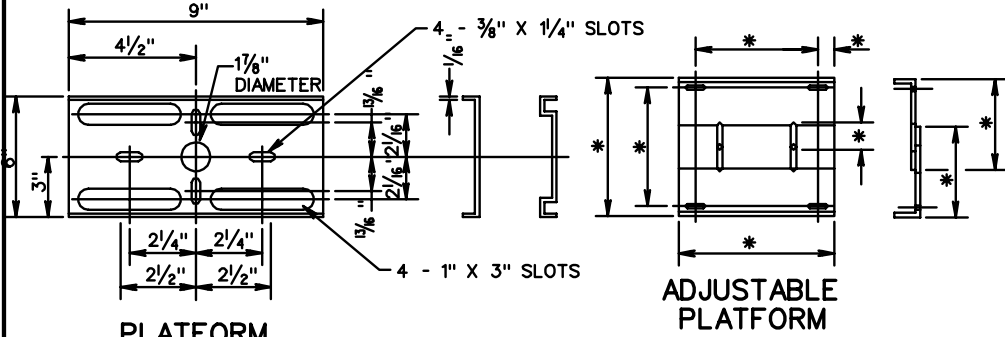

PLATFORM

ADJUSTABLE PLATFORM

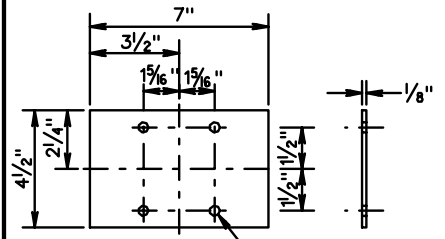

ANTI-TWIST PLATE

4 - 7/16" DIAMETER HOLES

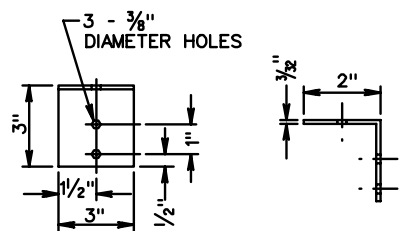

BRACKET

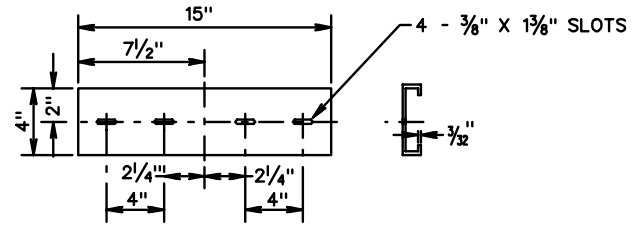

ADAPTER SHELF

NOTES:

- MAILBOXES SHALL BE OF LIGHT SHEET METAL OR PLASTIC CONSTR. CONFORMING TO THE REQUIREMENTS OF THE U.S. POSTAL SERVICE.
- MAILBOX SUPPORTS SHALL NOT BE SET IN CONCRETE UNLESS THE SUPPORT DESIGN HAS BEEN SHOWN TO BE SAFE BY CRASH TESTS WHEN SO INSTALLED.
- POSTS MAY BE 4" X 4" OR 4 1/2" DIAMETER WOOD POST, 2" DIAMETER STANDARD STRENGTH STEEL PIPE, OR OTHER STEEL OR ALUMINUM POST SHAPES OF EQUAL STRENGTHS.
- THE POST-TO-BOX ATTACHMENT DETAILS SHOULD BE OF SUFFICIENT STRENGTH TO PREVENT THE BOX FROM SEPARATING FROM THE POST TOP IF THE INSTALLATION IS STRUCK BY A VEHICLE. HARDWARE SHOWN IS SUGGESTED ONLY, ALL GUIDELINES AS REQ'D. BY THE U.S. POSTAL SERVICE MUST BE FOLLOWED.

* DIMENSIONS VARY ACCORDING TO THE SIZE OF THE MAIL BOX.

SPECIFICATION REFERENCE	
NONE	

STANDARD MAILBOX

VIRGINIA DEPARTMENT OF TRANSPORTATION

VDOT	
ROAD AND BRIDGE STANDARDS	
REVISION DATE	SHEET 1 OF 1
	603.01

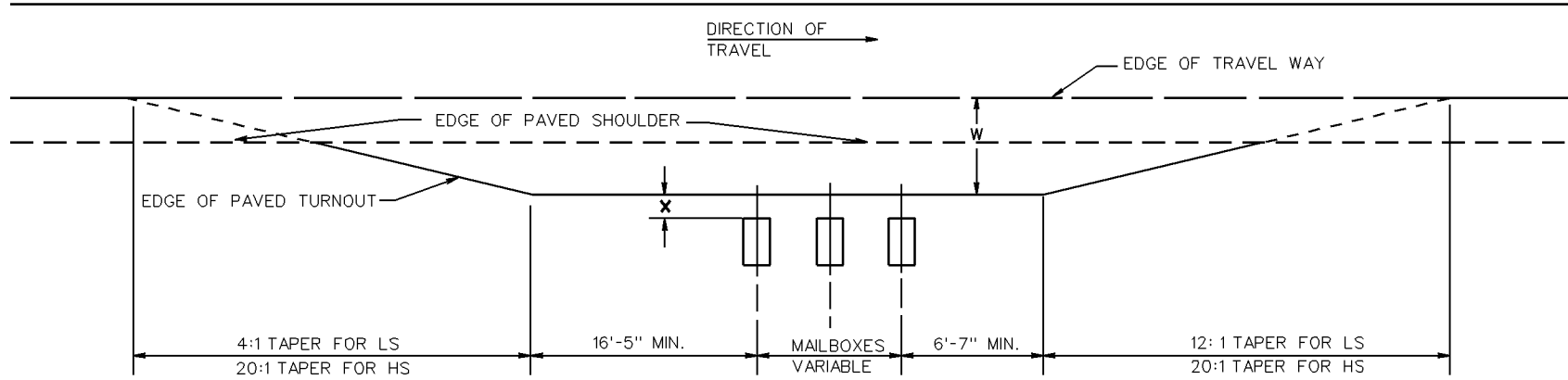

LS = A MINIMUM DESIGN FOR ROADS CARRYING LOW-SPEED TRAFFIC AND FOR LOCAL AND COLLECTOR ROADS.
 HS = FOR ROADS CARRYING HIGH-SPEED TRAFFIC.
 W = FOR SUGGESTED WIDTHS, SEE TABLE.
 MAILBOXES = FOR MAILBOX SPACING AND VARIABLE LENGTH, SEE SHEET 603.01
 X = 0" - 12" MAILBOX FACE OFFSET. SEE TABLE.

HIGHWAY TYPE AND ADT, (vpd)	WIDTH (W) OF ALL-WEATHER SURFACE TURNOUT OR AVAILABLE SHOULDER AT MAILBOX, (FT.) (SEE NOTE 1)		DISTANCE (X) FROM FACE OF MAILBOX IS TO BE OFFSET FROM EDGE OF TURNOUT OR USEABLE SHOULDER, (IN.)	
	PREFERRED	MINIMUM	PREFERRED	MINIMUM
RURAL HIGHWAY OVER 10,000	12	8	8 TO 12	0
RURAL HIGHWAY OVER 1,500 to 10,000	12	8		
RURAL HIGHWAY 400 to 1,500	10	8		
RURAL HIGHWAY UNDER 400	8	6 (SEE NOTE 2)		10 (SEE NOTE 3)
RESIDENTIAL STREET WITHOUT CURB OR ALL-WEATHER SHOULDER	6	0.00		
CURBED RESIDENTIAL STREET	NOT APPLICABLE		8 TO 12 (SEE NOTE 4)	6 (SEE NOTE 4)

ADT=AVERAGE DAILY TRAFFIC
 vpd=VEHICLES PER DAY

NOTES:

- IF THERE IS A NEED TO PROVIDE FOR INCREASED ACCESS, THE FOLLOWING MAY BE CONSIDERED IN CONJUNCTION WITH THE LOCAL POSTMASTER
 - PROVIDE A LEVEL CLEAR FLOOR SPACE 30" X 48" CENTERED ON THE BOX FOR EITHER SIDE OR FORWARD APPROACH.
 - PROVIDE AN ACCESSIBLE PASSAGE TO AND FROM THE MAILBOX AND PROJECTION INTO A CIRCULATION ROUTE (NO MORE THAN 4" IF BETWEEN 28" AND 80" AFF) SO THAT THE MAILBOX DOES NOT BECOME A PROTRUDING OBJECT FOR PEDESTRIANS WITH IMPAIRED VISION.
- STRIVE FOR A 6 FEET MIN.; HOWEVER, IN SOME SITUATIONS THIS MAY NOT BE PRACTICAL. IN THOSE CASES, PROVIDE AS MUCH AS POSSIBLE.
- IF A TURNOUT IS PROVIDED, THIS MAY REDUCE TO ZERO.
- BEHIND TRAFFIC-FACE OF CURB.

TURNOUT DETAIL

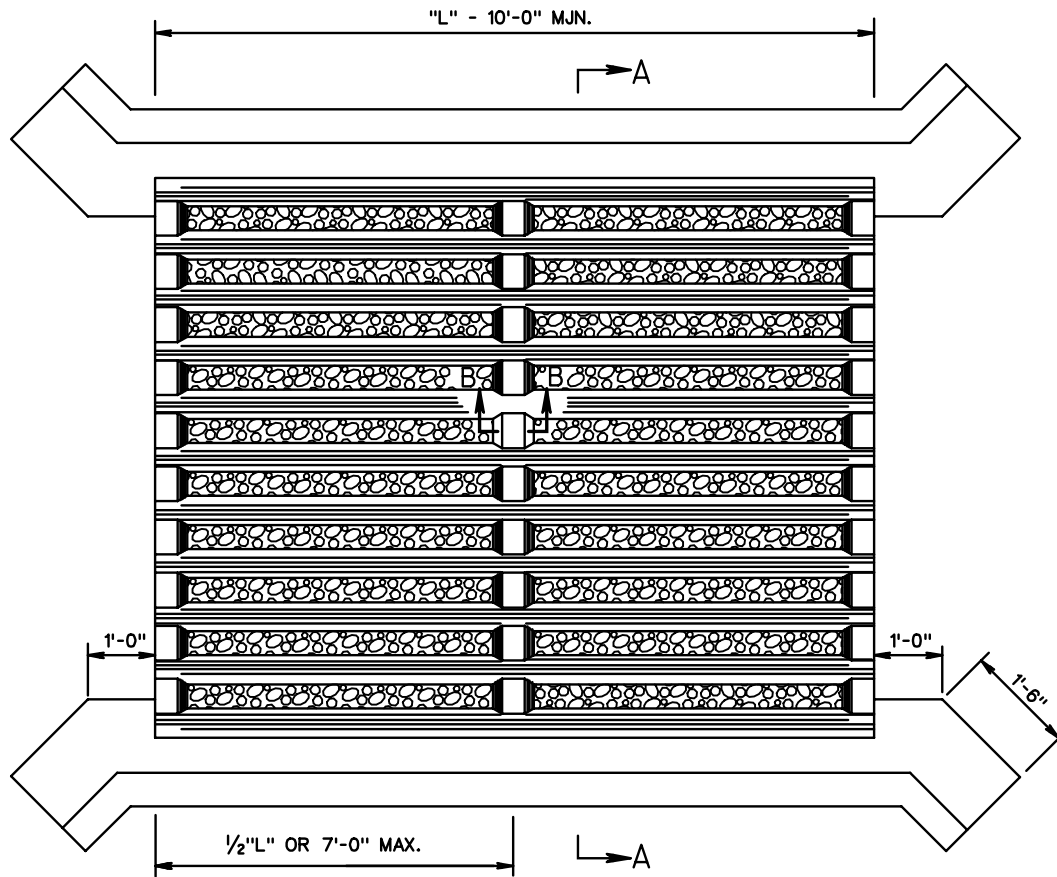

NOTES:
 ANY MANUFACTURERS FABRICATION MEETING OR EXCEEDING THE MINIMUM DESIGN REQUIREMENTS DETAILED HEREON WILL BE ACCEPTABLE.
 ALL CONCRETE IN PRECAST MEMBERS TO BE 4000 PSI
 CONCRETE IN FOOTING TO BE CLASS C1 OR CLASS A3.
 LENGTH TO BE AS SHOWN ON PLANS.

MINIMUM SECTIONAL AREA OF MEMBERS

- INTERMEDIATE RAIL— 28 SQ. IN.
- SIDE RAIL— 50 SQ. IN.
- BEAM— 48 SQ. IN.

PLAN VIEW

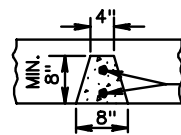

MINIMUM 2 BARS PER BEAM
 HAVING A MINIMUM TOTAL
 WEIGHT OF 2.004 LBS. PER FT.

SECTION B-B
 TYPICAL BEAM SECTION

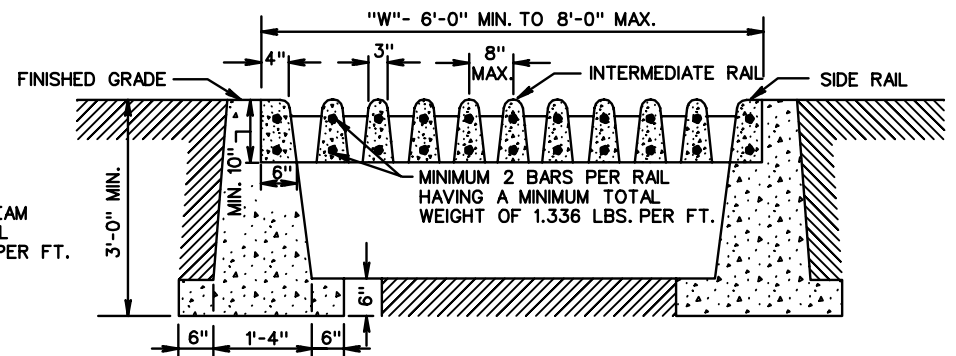

SECTION A-A

SPECIFICATION REFERENCE

302

PRECAST CONCRETE CATTLE GUARD

VIRGINIA DEPARTMENT OF TRANSPORTATION

VDOT

ROAD AND BRIDGE STANDARDS

REVISION DATE

SHEET 1 OF 1

604.01

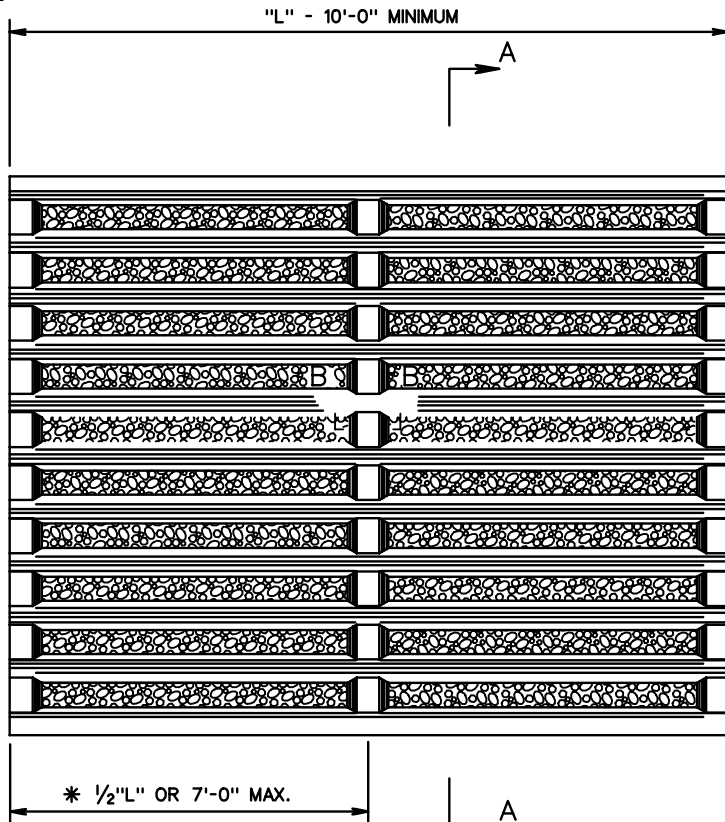

PLAN VIEW

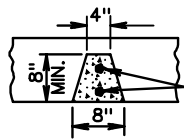

SECTION B-B
TYPICAL BEAM SECTION

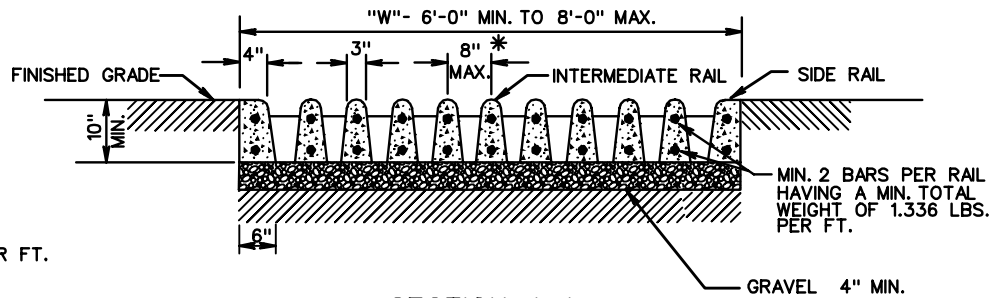

SECTION A-A

NOTES:
ANY MANUFACTURERS FABRICATION MEETING OR EXCEEDING THE MINIMUM DESIGN REQUIREMENTS DETAILED HEREON WILL BE ACCEPTABLE.

ALL CONCRETE IN PRECAST MEMBERS TO BE 4000 PSI.

LENGTH TO BE AS SHOWN ON PLANS.

* A RAIL SPACING OF 9 1/2" WOULD BE ALLOWED PROVIDED THE SPACE OF BEAMS DOES NOT EXCEED 3'.

MINIMUM SECTIONAL AREA
OF MEMBERS

- INTERMEDIATE RAIL - 28 SQ. IN.
- SIDE RAIL - 50 SQ. IN.
- BEAM - 48 SQ. IN.

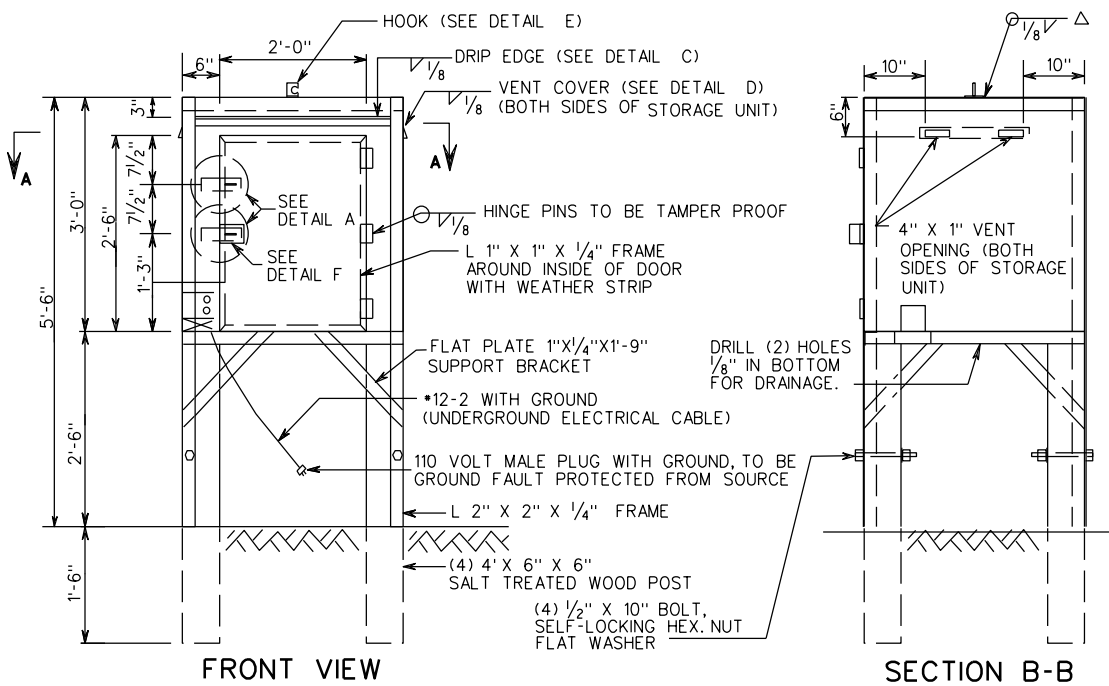

NOTES:

NO SEPARATE PAYMENT WILL BE MADE FOR FURNISHING, INSTALLING AND PROVIDING MAINTENANCE OF THE STORAGE FACILITY FOR NUCLEAR GAUGE AND THE PRICE THEREOF SHALL BE INCLUDED IN THE PRICE BID FOR FIELD OFFICE (TYPE) SPECIFIED, IN ACCORDANCE WITH SECTION 514 OF THE CURRENT ROAD AND BRIDGE SPECIFICATIONS.

BOX TO BE CONSTRUCTED OF A-36 SHEET STEEL 1/8" MIN. THICKNESS. WHEN WELDING TO FRAME USE 1/8" FILLET WELDS.

ALL FRAME WORK IS TO BE A-36 STEEL ANGLE L 2" X 2" X 1/4".

ALL FRAME WELDS ARE TO BE 1/4" FILLET OR BUTT WELDED ACCORDINGLY.

METAL SCREEN SHALL HAVE A MAXIMUM OF 50 SQUARES PER INCH TO A MINIMUM OF 25 SQUARES PER INCH AND BE SPOT WELDED TO INSIDE OF THE BOX OVER VENT OPENINGS.

△ THE HOOK SHALL BE WELDED TO THE CENTER OF THE TOP.

VENT OPENINGS SHALL BE PARTIALLY COVERED EXTERNALLY BY METAL VENT COVERS.

STORAGE UNIT SHALL BE PAINTED INTERNALLY AND EXTERNALLY WITH A ONE COAT ACRYLIC DIRECT TO METAL (DTM) COATING, WITH A THICKNESS OF 4-6 MILS (WET MIL THICKNESS). COLOR SHALL BE EQUAL TO FEDERAL STANDARD COLOR NO. 595-17886 (WHITE).

THE DESIGN IS TO BE 4" ID AND MOUNTED AT A 45° ANGLE OVER THE HASP OPENING IN THE DOOR.

OPTIONAL SHROUD DESIGN IS TO BE SUBMITTED FOR THE ENGINEERS REVIEW AND APPROVAL.

CONTRASTING PAINT IS REQUIRED TO DEPICT STORAGE AREA.

STORAGE UNIT TO HAVE TWO (2) TAMPER-RESISTANT HASPS WITH A LOCK BOX EACH, OPEN ON THE BOTTOM AND TOP.

A STEEL EYEBOLT SHALL BE INSTALLED IN THE FLOOR INSIDE THE CONTAINER TO ACCOMMODATE A LINKED SECURITY CHAIN. THE EYEBOLT MAY BE THROUGH BOLTED OR WELDED TO THE FLOOR AND SHALL HAVE A MINIMUM 1/2" DIAMETER EYE TO ALLOW THE GAUGE TO BE CHAINED AND LOCKED TO THE FLOOR OF THE FACILITY.

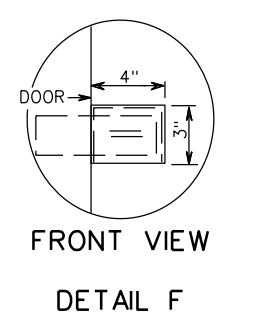
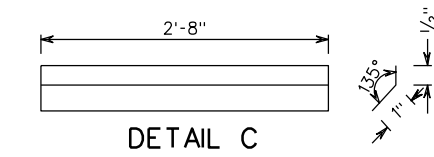
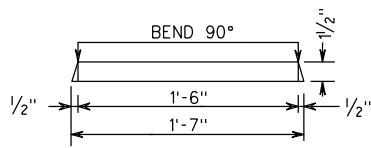
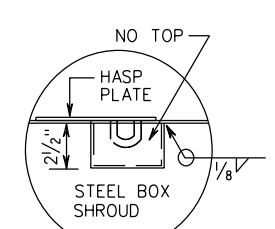
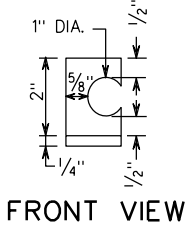
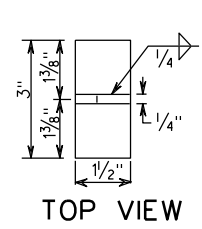
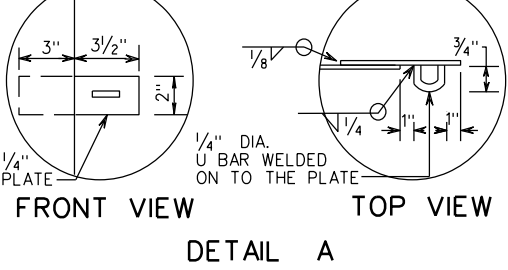
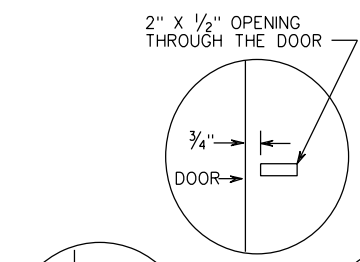
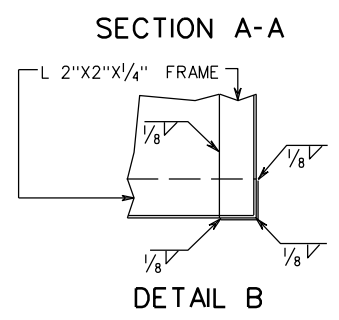
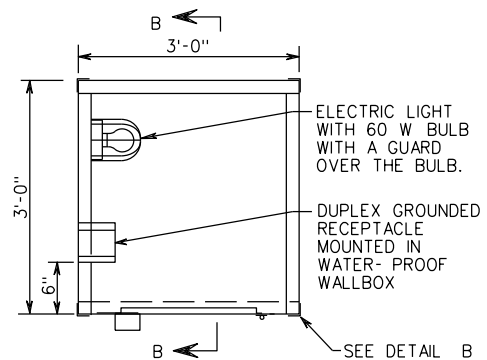

SPECIFICATION REFERENCE

STORAGE FACILITY FOR NUCLEAR GAUGE

VIRGINIA DEPARTMENT OF TRANSPORTATION

VDOT	
ROAD AND BRIDGE STANDARDS	
REVISION DATE	SHEET 1 OF 1
01/13	605.01

RU-1

DESIGN A

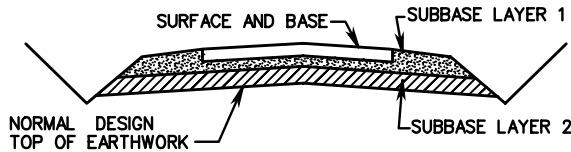

NORMAL ROADWAY DESIGN "A"

(SURFACE, BASE, AND ONE OR MORE COURSES OF SUBBASE MATERIAL ABOVE TOP OF EARTHWORK.)

DESIGN B

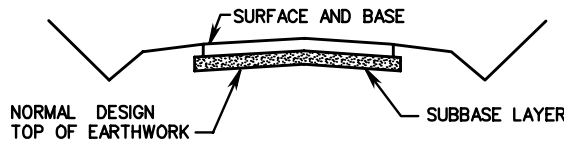

NORMAL ROADWAY DESIGN "B"

(SURFACE, BASE, AND SUBBASE ONLY. (SUBBASE NOT THROUGH SHOULDERS.)

DESIGN C

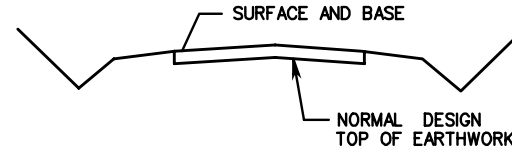

NORMAL ROADWAY DESIGN "C"

(SURFACE AND BASE COURSES ONLY.)

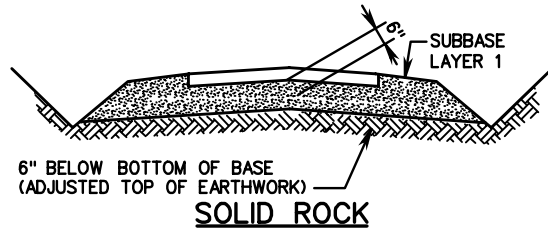

SOLID ROCK

REMOVE ROCK TO A POINT 6" BELOW BOTTOM OF BASE FOR ENTIRE WIDTH OF ROADWAY. BACKFILL WITH SUBBASE LAYER 1 USING BOTTOM 2" AS A LEVELING COURSE.

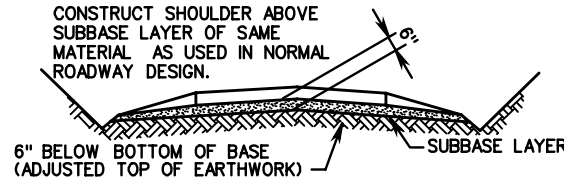

SOLID ROCK OR IRREGULAR ROCK OUTCROPPING, BOULDERS, SHALE OR OTHER NON-SOLID ROCK

REMOVE ROCK TO A POINT 6" BELOW BOTTOM OF BASE FOR ENTIRE WIDTH OF ROADWAY. BACKFILL WITH SUBBASE LAYER TO A DEPTH OF 6" FOR ENTIRE WIDTH OF ROADWAY USING BOTTOM 2" AS LEVELING COURSE. SHOULDER DESIGN ABOVE SUBBASE LAYER TO CONFORM TO NORMAL ROADWAY DESIGN AS SHOWN ON PLANS.

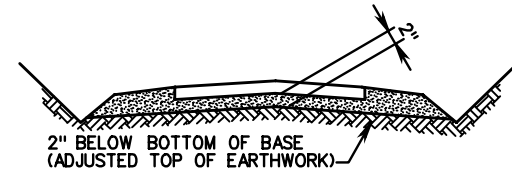

SOLID ROCK OR IRREGULAR ROCK OUTCROPPING, BOULDERS, SHALE OR OTHER NON-SOLID ROCK

EXCAVATE TO A POINT 2" BELOW BOTTOM OF BASE FOR ENTIRE WIDTH OF ROADWAY. BACKFILL WITH 2" OF ANY AGGREGATE MATERIAL FOR WHICH THERE IS A PAY ITEM IN THE CONTRACT AND USE AS A LEVELING COURSE.

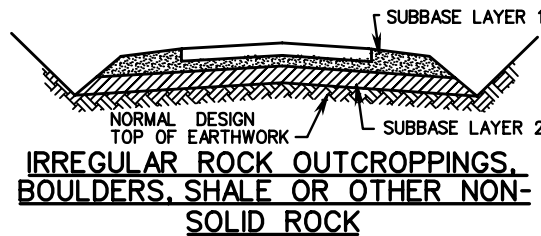

IRREGULAR ROCK OUTCROPPINGS, BOULDERS, SHALE OR OTHER NON-SOLID ROCK

EXCAVATE TO NORMAL DESIGN TOP OF EARTHWORK. BACKFILL WITH SUBBASE LAYER 1 AND SUBBASE LAYER 2 TO NORMAL DESIGN DEPTHS.

NOTES:

APPLICABLE METHOD AS SHOWN HEREON IS TO BE USED AT SUCH LOCATIONS AS DESIGNATED BY THE ENGINEER.

ROCK CUT SECTIONS

IN DESIGN "A", IF CEMENT OR LIME SUBGRADE STABILIZATION IS INCLUDED IN THE NORMAL ROADWAY DESIGN, IT SHOULD BE ELIMINATED WHEN SOLID ROCK IS ENCOUNTERED. WHERE IRREGULAR ROCK OUTCROPPINGS, BOULDERS, SHALE OR OTHER NON-SOLID ROCK IS ENCOUNTERED, SUBSTITUTE AGGREGATE BASE OR SUBBASE MATERIAL FOR THE SUBGRADE STABILIZATION ON AN INCH FOR INCH BASIS USING BOTTOM 2" AS A LEVELING COURSE.

IN DESIGN "B", IF CEMENT OR LIME SUBGRADE STABILIZATION IS INCLUDED IN THE NORMAL ROADWAY DESIGN, IT SHOULD BE ELIMINATED WHEN SOLID ROCK, IRREGULAR OUTCROPPINGS, BOULDERS, SHALE OR OTHER NON-SOLID ROCK IS ENCOUNTERED. SUBSTITUTE AGGREGATE BASE OR SUBBASE MATERIAL FOR THE STABILIZATION ON AN INCH FOR INCH BASIS, USING BOTTOM 2" AS A LEVELING COURSE.

IN DESIGN "C", IF CEMENT OR LIME SUBGRADE STABILIZATION IS INCLUDED IN THE NORMAL ROADWAY DESIGN, ELIMINATED WHEN SOLID ROCK, IRREGULAR ROCK OUTCROPPINGS, BOULDERS, SHALE OR OTHER NON-SOLID ROCK IS ENCOUNTERED, SUBSTITUTE AGGREGATE BASE OR SUBBASE MATERIAL FOR THE STABILIZATION ON AN INCH FOR INCH BASIS USING BOTTOM 2" AS A LEVELING COURSE.

IN DESIGN "A", IF CEMENT STABILIZATION OF AGGREGATE BASE OR SUBBASE MATERIAL IS INCLUDED AS AN INTEGRAL PART OF THE PAVEMENT STRUCTURE ABOVE SUBGRADE ELEVATION ELIMINATE THE CEMENT WHEN SOLID ROCK IS ENCOUNTERED.

IN DESIGN "B", IF CEMENT STABILIZATION OF AGGREGATE BASE OR SUBBASE MATERIAL IS INCLUDED AS AN INTEGRAL PART OF THE PAVEMENT STRUCTURE ABOVE SUBGRADE ELEVATION, ELIMINATE THE CEMENT WHEN SOLID ROCK OR IRREGULAR ROCK OUTCROPPINGS, BOULDERS, SHALE OR OTHER NON-SOLID ROCK IS ENCOUNTERED.

ROCK FILL SECTIONS

WHEN A FILL SECTION IS BUILT USING GOOD QUALITY STONE AT SUBGRADE ELEVATION AND 2' OR MORE BELOW SUBGRADE ELEVATION, FILL SECTIONS SHALL BE HANDLED IN THE SAME MANNER AS ROCK CUT-SECTIONS. GOOD QUALITY ROCK IN FILL SECTIONS SHOULD BE CONSIDERED THE SAME AS SOLID ROCK IN CUT SECTIONS SHOWN IN DESIGN "A". ALL OTHER ROCK FILL SUBGRADE CONDITIONS SHALL BE HANDLED ACCORDING TO DESIGN A, B OR C AS SHOWN.



ROAD AND BRIDGE STANDARDS

STANDARD METHODS OF UNDERCUTTING ROCK

SPECIFICATION REFERENCE

SHEET 1 OF 1

REVISION DATE

303

606.01

VIRGINIA DEPARTMENT OF TRANSPORTATION

SLOPE STAKES ON TANGENTS

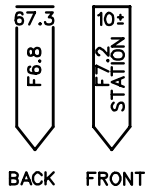
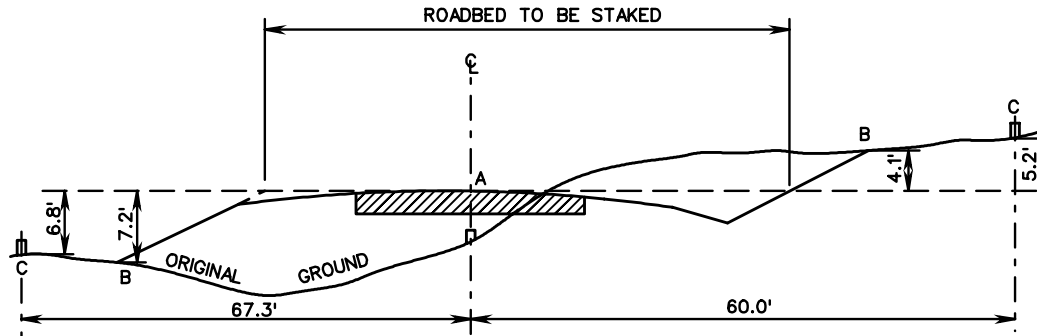

THE FRONT OF THE STAKE SHALL INDICATE THE CUT OR FILL TO THE SLOPE INTERSECTION (VERTICAL DISTANCE A TO B), THE OFFSET DISTANCE (B TO C), AND THE STATION.

THE BACK OF THE STAKE SHALL INDICATE THE CUT OR FILL AT THE POINT WHERE THE STAKE IS SET (VERTICAL DISTANCE A TO C), AND THE DISTANCE TO THE CENTERLINE (A TO C).

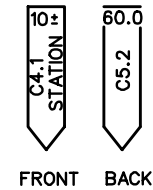

SLOPE STAKES ON CURVES

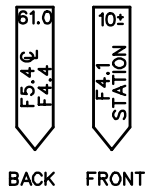
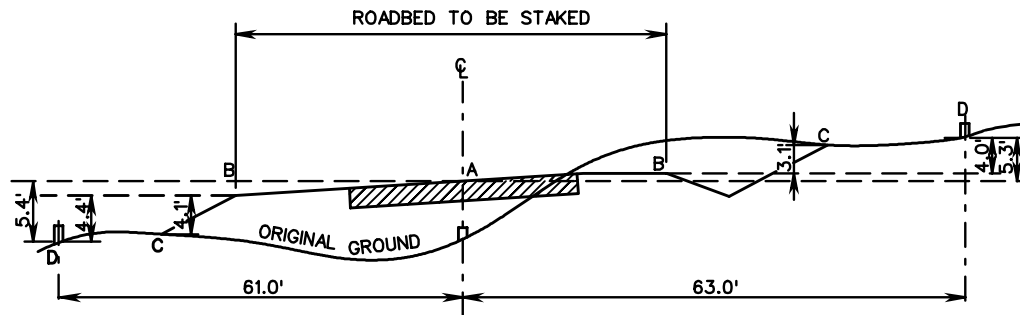

THE FRONT OF THE STAKE SHALL INDICATE THE CUT OR FILL TO THE SLOPE INTERSECTION INCLUDING SUPERELEVATION (VERTICAL DISTANCE B TO C), THE OFFSET DISTANCE (C TO D), AND THE STATION.

THE BACK OF THE STAKE SHALL INDICATE THE CUT OR FILL TO CENTERLINE AT THE POINT WHERE THE STAKE IS SET (VERTICAL DISTANCE A TO D), THE CUT OR FILL WHERE THE STAKE IS SET, INCLUDING SUPERELEVATION (VERTICAL DISTANCE B TO D), AND THE DISTANCE TO CENTERLINE (A TO D).

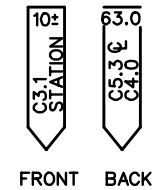

SPECIFICATION REFERENCE

105

STANDARD METHOD OF SETTING AND MARKING SLOPE STAKES

VIRGINIA DEPARTMENT OF TRANSPORTATION

VDOT

ROAD AND BRIDGE STANDARDS

REVISION DATE

SHEET 1 OF 1

607.01

THIS PAGE INTENTIONALLY LEFT BLANK



ROAD AND BRIDGE STANDARDS

SHEET 1 OF 1

REVISION DATE

607.02

VIRGINIA DEPARTMENT OF TRANSPORTATION

SPECIFICATION
REFERENCE

MIDDLE ORDINATE OR RADIAL DISTANCE FROM CENTER LINE OF INSIDE LANE TO OBSTRUCTION TO VIEW (M)

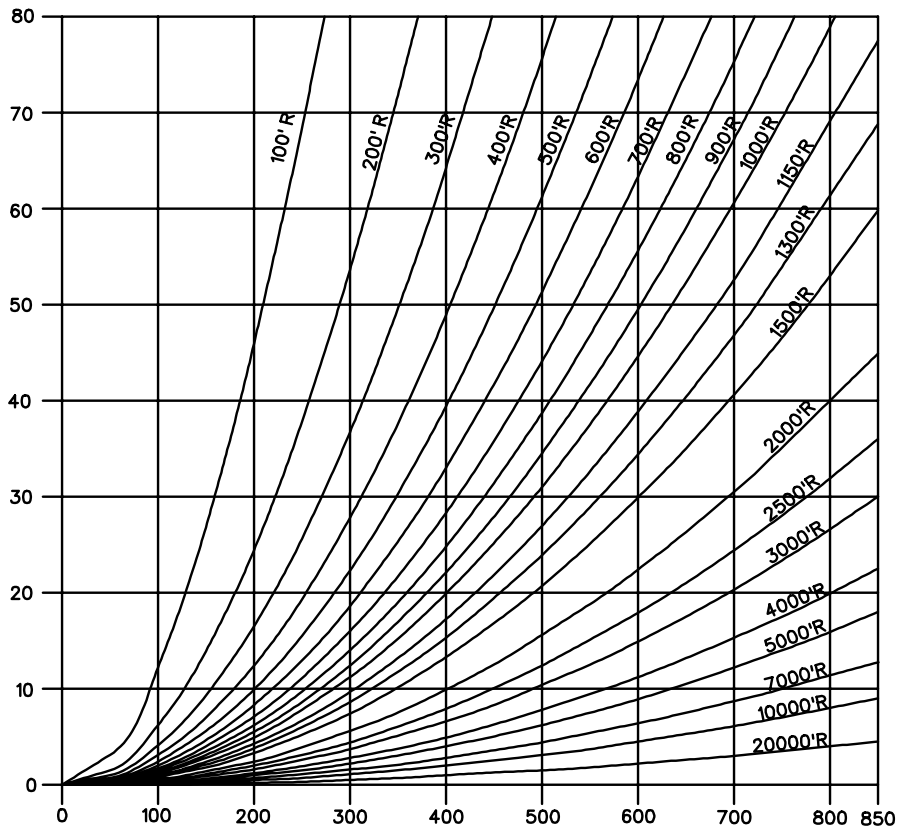

LENGTH OF ARC SUBTENDED OR CLEAR SIGHT DISTANCE MEASURED ALONG CENTER LINE OF INSIDE LANE (S)

INTERMEDIATE VALUES OF S AND M NOT LISTED ON GRAPH CAN

MARK EQUAL TO 10' SIGHT DISTANCE (S) AND 1' OF RADIAL DISTANCE (M).

* 2.0 FEET STOPPING
3.5 FEET PASSING
LINE OF SIGHT AT MID POINT TO BE 2.0' ABOVE EDGE OF PAVEMENT FOR STOPPING SIGHT DISTANCE, AND 4.0' FOR PASSING SIGHT DISTANCE.

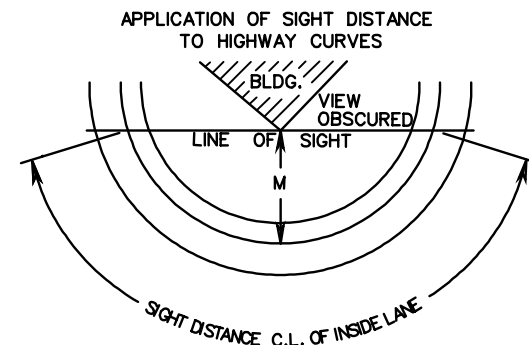

SIGHT DISTANCES ON HORIZONTAL CURVES
HEIGHT OF EYE 3.5 FT. : HEIGHT OF OBJECT 2.0 AND 3.5 FT.

VIRGINIA DEPARTMENT OF TRANSPORTATION



ROAD AND BRIDGE STANDARDS

REVISION DATE

SHEET 1 OF 1

608.01

SD-2		WHEN S>L: $S = \frac{664.575}{A} + \frac{L}{2}$																			WHEN S<L: $S = 36.458 \sqrt{\frac{L}{A}}$	S = SIGHT DISTANCE IN FEET	A = ALGEBRAIC DIFFERENCE OF GRADES IN PERCENT
A = ALGEBRAIC DIFFERENCE OF GRADES IN PERCENT	L = LENGTH OF VERTICAL CURVE IN FEET																						
	50	100	150	200	250	300	350	400	450	500	550	600	650	700	750	800	850	900	950	1000			
2.0	357	382	407	432	457	482	507	532	557	582	607	632	657	682	706	729	752	773	795	815	2.0		
2.5	291	316	341	366	391	416	441	466	491	516	541	565	588	610	631	652	672	692	711	729	2.5		
3.0	247	272	297	322	347	372	397	422	447	471	494	516	537	557	576	595	614	631	649	666	3.0		
3.5	215	240	265	290	315	340	365	390	413	436	457	477	497	516	534	551	568	585	601	616	3.5		
4.0	191	216	241	266	291	316	341	365	387	408	428	447	465	482	499	516	531	547	562	576	4.0		
4.5	173	198	223	248	273	298	322	344	365	384	403	421	438	455	471	486	501	516	530	543	4.5		
5.0	158	183	208	233	258	282	305	326	346	365	382	399	416	431	447	461	475	489	503	516	5.0		
5.5	146	171	196	221	246	269	291	311	330	348	365	381	396	411	426	440	453	466	479	492	5.5		
6.0	136	161	186	211	235	258	278	298	316	333	349	365	379	394	408	421	434	447	459	471	6.0		
6.5	127	152	177	202	226	248	268	286	303	320	335	350	365	378	392	404	417	429	441	452	6.5		
7.0	120	145	170	195	218	239	258	276	292	308	323	338	351	365	377	390	402	413	425	436	7.0		
7.5	114	139	164	188	210	231	249	266	282	298	312	326	339	352	365	377	388	399	410	421	7.5		
8.0	108	133	158	182	204	223	241	258	273	288	302	316	329	341	353	365	376	387	397	408	8.0		
8.5	103	128	153	177	198	217	234	250	265	280	293	306	319	331	342	354	365	375	385	395	8.5		
9.0	99	124	149	172	192	210	227	243	258	272	285	298	310	322	333	344	354	365	375	384	9.0		
9.5	95	120	145	167	187	205	221	237	251	264	277	290	302	313	324	335	345	355	365	374	9.5		
10.0	91	116	141	163	182	200	216	231	245	258	270	282	294	305	316	326	336	346	355	365	10.0		
10.5	88	113	138	159	178	195	210	225	239	252	264	276	287	298	308	318	328	338	347	356	10.5		
11.0	85	110	135	155	174	190	206	220	233	246	258	269	280	291	301	311	320	330	339	348	11.0		
11.5	83	108	132	152	170	186	201	215	228	240	252	263	274	284	294	304	313	323	331	340	11.5		
12.0	80	105	129	149	166	182	197	210	223	235	247	258	268	278	288	298	307	316	324	333	12.0		
12.5	78	103	126	146	163	179	193	206	219	231	242	253	263	273	282	292	301	309	318	326	12.5		
13.0	76	101	124	143	160	175	189	202	215	226	237	248	258	268	277	286	295	303	312	320	13.0		
13.5	74	99	122	140	157	172	186	198	210	222	233	243	253	263	272	281	289	298	306	314	13.5		
14.0	72	97	119	138	154	169	182	195	207	218	229	239	248	258	267	276	284	292	300	308	14.0		
14.5	71	96	117	135	151	166	179	191	203	214	225	235	244	253	262	271	279	287	295	303	14.5		
15.0	69	94	115	133	149	163	176	188	200	210	221	231	240	249	258	266	274	282	290	298	15.0		
16.0	67	91	112	129	144	158	171	182	193	204	214	223	232	241	250	258	266	273	281	288	16.0		
17.0	64	88	108	125	140	153	165	177	188	198	207	217	225	234	242	250	258	265	273	280	17.0		
18.0	62	86	105	122	136	149	161	172	182	192	202	210	219	227	235	243	251	258	265	272	18.0		
19.0	60	84	102	118	132	145	156	167	177	187	196	205	213	221	229	237	244	251	258	264	19.0		
20.0	58	82	100	115	129	141	153	163	173	182	191	200	208	216	223	231	238	245	251	258	20.0		

A = ALGEBRAIC DIFFERENCE OF GRADES IN PERCENT	WHEN S > L: $S = \frac{664.575}{A} + \frac{L}{2}$																			WHEN S < L: $S = 36.458 \sqrt{\frac{L}{A}}$																			SD-2	
	S = SIGHT DISTANCE IN FEET																				A = ALGEBRAIC DIFFERENCE OF GRADES IN PERCENT																			
	L = LENGTH OF VERTICAL CURVE IN FEET																																							
	1050	1100	1150	1200	1250	1300	1350	1400	1450	1500	1550	1600	1650	1700	1750	1800	1850	1900	1950	2000																				
2.0	835	855	874	893	911	930	947	965	982	998	1015	1031	1047	1063	1078	1094	1109	1124	1138	1153	2.0																			
2.5	747	765	782	799	815	831	847	863	878	893	908	922	937	951	965	978	992	1005	1018	1031	2.5																			
3.0	682	698	714	729	744	759	773	788	802	815	829	842	855	868	881	893	905	918	930	941	3.0																			
3.5	631	646	661	675	689	703	716	729	742	755	767	780	792	803	815	827	838	849	861	872	3.5																			
4.0	591	605	618	631	644	657	670	682	694	706	718	729	740	752	763	773	784	795	805	815	4.0																			
4.5	557	570	583	595	608	620	631	643	654	666	677	687	698	709	719	729	739	749	759	769	4.5																			
5.0	528	541	553	565	576	588	599	610	621	631	642	652	662	672	682	692	701	711	720	729	5.0																			
5.5	504	516	527	539	550	561	571	582	592	602	612	622	631	641	650	660	669	678	686	695	5.5																			
6.0	482	494	505	516	526	537	547	557	567	576	586	595	605	614	623	631	640	649	657	666	6.0																			
6.5	463	474	485	495	506	516	525	535	545	554	563	572	581	590	598	607	615	623	631	640	6.5																			
7.0	447	457	467	477	487	497	506	516	525	534	543	551	560	568	576	585	593	601	609	616	7.0																			
7.5	431	442	451	461	471	480	489	498	507	516	524	533	541	549	557	565	573	580	588	595	7.5																			
8.0	418	428	437	447	456	465	474	482	491	499	507	516	524	531	539	547	554	562	569	576	8.0																			
8.5	405	415	424	433	442	451	459	468	476	484	492	500	508	516	523	531	538	545	552	559	8.5																			
9.0	394	403	412	421	430	438	447	455	463	471	478	486	494	501	508	516	523	530	537	543	9.0																			
9.5	383	392	401	410	418	426	435	443	450	458	466	473	480	488	495	502	509	516	522	529	9.5																			
10.0	374	382	391	399	408	416	424	431	439	447	454	461	468	475	482	489	496	503	509	516	10.0																			
10.5	365	373	382	390	398	406	413	421	428	436	443	450	457	464	471	477	484	490	497	503	10.5																			
11.0	356	365	373	381	389	396	404	411	419	426	433	440	447	453	460	466	473	479	485	492	11.0																			
11.5	348	357	365	372	380	388	395	402	409	416	423	430	437	443	450	456	462	469	475	481	11.5																			
12.0	341	349	357	365	372	379	387	394	401	408	414	421	428	434	440	447	453	459	465	471	12.0																			
12.5	334	342	350	357	365	372	379	386	393	399	406	412	419	425	431	437	444	449	455	461	12.5																			
13.0	328	335	343	350	358	365	372	378	385	392	398	404	411	417	423	429	435	441	447	452	13.0																			
13.5	322	329	336	344	351	358	365	371	378	384	391	397	403	409	415	421	427	433	438	444	13.5																			
14.0	316	323	330	338	344	351	358	365	371	377	384	390	396	402	408	413	419	425	430	436	14.0																			
14.5	310	318	325	332	339	345	352	358	365	371	377	383	389	395	401	406	412	417	423	428	14.5																			
15.0	305	312	319	326	333	339	346	352	358	365	371	377	382	388	394	399	405	410	416	421	15.0																			
16.0	295	302	309	316	322	329	335	341	347	353	359	365	370	376	381	387	392	397	402	408	16.0																			
17.0	287	293	300	306	313	319	325	331	337	342	348	354	359	365	370	375	380	385	390	395	17.0																			
18.0	278	285	291	298	304	310	316	322	327	333	338	344	349	354	359	365	370	375	379	384	18.0																			
19.0	271	277	284	290	296	302	307	313	318	324	329	335	340	345	350	355	360	365	369	374	19.0																			
20.0	264	270	276	282	288	294	300	305	310	316	321	326	331	336	341	346	351	355	360	365	20.0																			

SIGHT DISTANCE ON VERTICAL CURVES

HEIGHT OF EYE = 3.5 FEET

HEIGHT OF OBJECT = 0.5 FEET

VIRGINIA DEPARTMENT OF TRANSPORTATION



ROAD AND BRIDGE STANDARDS

REVISION DATE

SHEET 2 OF 2

608.03

SD-3		WHEN S > L: $S = \frac{1546.362}{A} + \frac{L}{2}$																			WHEN S < L: $S = 55.612 \sqrt{\frac{L}{A}}$	S = SIGHT DISTANCE IN FEET	A = ALGEBRAIC DIFFERENCE OF GRADES IN PERCENT
A = ALGEBRAIC DIFFERENCE OF GRADES IN PERCENT	L = LENGTH OF VERTICAL CURVE IN FEET																						
	50	100	150	200	250	300	350	400	450	500	550	600	650	700	750	800	850	900	950	1000			
2.0	798	823	848	873	898	923	948	973	998	1023	1048	1073	1098	1123	1148	1173	1198	1223	1248	1273	2.0		
2.5	644	669	694	719	744	769	794	819	844	869	894	919	944	969	994	1019	1044	1069	1094	1119	2.5		
3.0	540	565	590	615	640	665	690	715	740	765	790	815	840	865	890	915	940	965	990	1015	3.0		
3.5	467	492	517	542	567	592	617	642	667	692	717	742	767	792	817	842	867	892	916	940	3.5		
4.0	412	437	462	487	512	537	562	587	612	637	662	687	712	737	762	786	811	834	857	879	4.0		
4.5	369	394	419	444	469	494	519	544	569	594	619	644	669	694	718	741	764	786	808	829	4.5		
5.0	334	359	384	409	434	459	484	509	534	559	584	609	634	658	681	703	725	746	767	786	5.0		
5.5	306	331	356	381	406	431	456	481	506	531	556	581	605	627	649	671	691	711	731	750	5.5		
6.0	283	308	333	358	383	408	433	458	483	508	532	556	579	601	622	642	662	681	700	718	6.0		
6.5	263	288	313	338	363	388	413	438	463	488	512	534	556	577	597	617	636	654	672	690	6.5		
7.0	246	271	296	321	346	371	396	421	446	470	493	515	536	556	576	595	613	631	648	665	7.0		
7.5	231	256	281	306	331	356	381	406	431	454	476	497	518	537	556	574	592	609	626	642	7.5		
8.0	218	243	268	293	318	343	368	393	417	440	461	482	501	520	538	556	573	590	606	622	8.0		
8.5	207	232	257	282	307	332	357	381	405	427	447	467	486	505	522	540	556	572	588	603	8.5		
9.0	197	222	247	272	297	322	347	371	393	415	435	454	473	490	508	524	540	556	571	586	9.0		
9.5	188	213	238	263	288	313	338	361	383	403	423	442	460	477	494	510	526	541	556	571	9.5		
10.0	180	205	230	255	280	305	329	352	373	393	412	431	448	465	482	497	513	528	542	556	10.0		
10.5	172	197	222	247	272	297	321	343	364	384	402	420	438	454	470	485	500	515	529	543	10.5		
11.0	166	191	216	241	266	290	314	335	356	375	393	411	427	444	459	474	489	503	517	530	11.0		
11.5	159	184	209	234	259	284	307	328	348	367	385	402	418	434	449	464	478	492	505	519	11.5		
12.0	154	179	204	229	254	278	300	321	341	359	376	393	409	425	440	454	468	482	495	508	12.0		
12.5	149	174	199	224	249	272	294	315	334	352	369	385	401	416	431	445	459	472	485	497	12.5		
13.0	144	169	194	219	244	267	289	308	327	345	362	378	393	408	422	436	450	463	475	488	13.0		
13.5	140	165	190	215	239	262	283	303	321	338	355	371	386	400	415	428	441	454	467	479	13.5		
14.0	135	160	185	210	235	257	278	297	315	332	349	364	379	393	407	420	433	446	458	470	14.0		
14.5	132	157	182	207	231	253	273	292	310	327	343	358	372	386	400	413	426	438	450	462	14.5		
15.0	128	153	178	203	227	249	269	287	305	321	337	352	366	380	393	406	419	431	443	454	15.0		
16.0	122	147	172	197	220	241	260	278	295	311	326	341	354	368	381	393	405	417	429	440	16.0		
17.0	116	141	166	191	213	234	252	270	286	302	316	330	344	357	369	381	393	405	416	427	17.0		
18.0	111	136	161	185	207	227	245	262	278	293	307	321	334	347	359	371	382	393	404	415	18.0		
19.0	106	131	156	180	202	221	239	255	271	285	299	313	325	338	349	361	372	383	393	403	19.0		
20.0	102	127	152	176	197	215	233	249	264	278	292	305	317	329	341	352	363	373	383	393	20.0		



ROAD AND BRIDGE STANDARDS

SHEET 1 OF 2

REVISION DATE

608.04

SIGHT DISTANCE ON VERTICAL CURVES

HEIGHT OF EYE = 3.5 FEET

HEIGHT OF OBJECT = 4.25 FEET

VIRGINIA DEPARTMENT OF TRANSPORTATION

A = ALGEBRAIC DIFFERENCE OF GRADES IN PERCENT	WHEN S > L: $S = \frac{1546.362}{A} + \frac{L}{2}$																			WHEN S < L: $S = 55.612\sqrt{\frac{L}{A}}$																			SD-3	
	L = LENGTH OF VERTICAL CURVE IN FEET																																						A = ALGEBRAIC DIFFERENCE OF GRADES IN PERCENT	
	1050	1100	1150	1200	1250	1300	1350	1400	1450	1500	1550	1600	1650	1700	1750	1800	1850	1900	1950	2000																				
2.0	1298	1323	1348	1373	1398	1423	1448	1473	1498	1523	1548	1573	1597	1621	1645	1668	1691	1714	1736	1759	2.0																			
2.5	1144	1169	1194	1219	1244	1268	1292	1316	1339	1362	1385	1407	1429	1450	1471	1492	1513	1533	1553	1573	2.5																			
3.0	1040	1065	1089	1112	1135	1158	1180	1201	1223	1244	1264	1284	1304	1324	1343	1362	1381	1400	1418	1436	3.0																			
3.5	963	986	1008	1030	1051	1072	1092	1112	1132	1151	1170	1189	1207	1226	1244	1261	1279	1296	1313	1329	3.5																			
4.0	901	922	943	963	983	1003	1022	1040	1059	1077	1095	1112	1129	1146	1163	1180	1196	1212	1228	1244	4.0																			
4.5	849	869	889	908	927	945	963	981	998	1015	1032	1049	1065	1081	1097	1112	1128	1143	1158	1172	4.5																			
5.0	806	825	843	862	879	897	914	931	947	963	979	995	1010	1025	1040	1055	1070	1084	1098	1112	5.0																			
5.5	768	786	804	821	838	855	871	887	903	918	934	949	963	978	992	1006	1020	1034	1047	1060	5.5																			
6.0	736	753	770	786	803	819	834	849	865	879	894	908	922	936	950	963	977	990	1003	1015	6.0																			
6.5	707	723	740	756	771	786	801	816	831	845	859	873	886	899	912	925	938	951	963	975	6.5																			
7.0	681	697	713	728	743	758	772	786	800	814	828	841	854	867	879	892	904	916	928	940	7.0																			
7.5	658	673	689	703	718	732	746	760	773	786	799	812	825	837	849	862	873	885	897	908	7.5																			
8.0	637	652	667	681	695	709	722	736	749	761	774	786	799	811	823	834	846	857	868	879	8.0																			
8.5	618	633	647	661	674	688	701	714	726	739	751	763	775	786	798	809	820	831	842	853	8.5																			
9.0	601	615	629	642	655	668	681	694	706	718	730	741	753	764	775	786	797	808	819	829	9.0																			
9.5	585	598	612	625	638	651	663	675	687	699	710	722	733	744	755	765	776	786	797	807	9.5																			
10.0	570	583	596	609	622	634	646	658	670	681	692	703	714	725	736	746	756	767	777	786	10.0																			
10.5	556	569	582	595	607	619	631	642	654	665	676	686	697	708	718	728	738	748	758	768	10.5																			
11.0	543	556	569	581	593	605	616	627	638	649	660	671	681	691	701	711	721	731	740	750	11.0																			
11.5	531	544	556	568	580	591	603	614	624	635	646	656	666	676	686	696	705	715	724	733	11.5																			
12.0	520	532	544	556	568	579	590	601	611	622	632	642	652	662	672	681	691	700	709	718	12.0																			
12.5	510	522	533	545	556	567	578	589	599	609	619	629	639	649	658	667	677	686	695	703	12.5																			
13.0	500	512	523	534	545	556	567	577	587	597	607	617	627	636	645	654	663	672	681	690	13.0																			
13.5	490	502	513	524	535	546	556	566	576	586	596	605	615	624	633	642	651	660	668	677	13.5																			
14.0	482	493	504	515	525	536	546	556	566	576	585	595	604	613	622	631	639	648	656	665	14.0																			
14.5	473	484	495	506	516	527	537	546	556	566	575	584	593	602	611	620	628	637	645	653	14.5																			
15.0	465	476	487	497	508	518	528	537	547	556	565	574	583	592	601	609	618	626	634	642	15.0																			
16.0	451	461	471	482	492	501	511	520	529	538	547	556	565	573	582	590	598	606	614	622	16.0																			
17.0	437	447	457	467	477	486	496	505	514	522	531	540	548	556	564	572	580	588	596	603	17.0																			
18.0	425	435	445	454	463	473	482	490	499	508	516	524	532	540	548	556	564	571	579	586	18.0																			
19.0	413	423	433	442	451	460	469	477	486	494	502	510	518	526	534	541	549	556	563	571	19.0																			
20.0	403	412	422	431	440	448	457	465	474	482	490	497	505	513	520	528	535	542	549	556	20.0																			

SIGHT DISTANCE ON VERTICAL CURVES

HEIGHT OF EYE = 3.5 FEET

HEIGHT OF OBJECT = 4.25 FEET

VIRGINIA DEPARTMENT OF TRANSPORTATION



ROAD AND BRIDGE STANDARDS

REVISION DATE

SHEET 2 OF 2

608.05

SD-4		WHEN S > L: $S = \frac{1079.15}{A} + \frac{L}{2}$																			WHEN S < L: $S = 46.454 \sqrt{\frac{L}{A}}$	S = SIGHT DISTANCE IN FEET	A = ALGEBRAIC DIFFERENCE OF GRADES IN PERCENT
A = ALGEBRAIC DIFFERENCE OF GRADES IN PERCENT	L - LENGTH OF VERTICAL CURVE IN FEET																						
	50	100	150	200	250	300	350	400	450	500	550	600	650	700	750	800	850	900	950	1000			
2.0	565	590	615	640	665	690	715	740	765	790	815	840	865	890	915	940	965	990	1015	1040	2.0		
2.5	457	482	507	532	557	582	607	632	657	682	707	732	757	782	807	832	857	881	906	929	2.5		
3.0	385	410	435	460	485	510	535	560	585	610	635	660	685	710	735	759	782	805	827	848	3.0		
3.5	333	358	383	408	433	458	483	508	533	558	583	608	633	657	680	702	724	745	765	785	3.5		
4.0	295	320	345	370	395	420	445	470	495	520	545	569	592	615	636	657	677	697	716	735	4.0		
4.5	265	290	315	340	365	390	415	440	465	490	514	536	558	579	600	619	638	657	675	692	4.5		
5.0	241	266	291	316	341	366	391	416	441	465	487	509	530	550	569	588	606	623	640	657	5.0		
5.5	221	246	271	296	321	346	371	396	420	443	465	485	505	524	542	560	577	594	611	626	5.5		
6.0	205	230	255	280	305	330	355	379	402	424	445	465	484	502	519	536	553	569	585	600	6.0		
6.5	191	216	241	266	291	316	341	364	387	407	427	446	465	482	499	515	531	547	562	576	6.5		
7.0	179	204	229	254	279	304	328	351	372	393	412	430	448	465	481	497	512	527	541	555	7.0		
7.5	169	194	219	244	269	294	317	339	360	379	398	415	432	449	465	480	495	509	523	536	7.5		
8.0	160	185	210	235	260	284	307	328	348	367	385	402	419	435	450	465	479	493	506	519	8.0		
8.5	152	177	202	227	252	276	298	319	338	356	374	390	406	422	436	451	465	478	491	504	8.5		
9.0	145	170	195	220	245	268	290	310	328	346	363	379	395	410	424	438	451	465	477	490	9.0		
9.5	139	164	189	214	238	261	282	301	320	337	353	369	384	399	413	426	439	452	465	477	9.5		
10.0	133	158	183	208	232	254	275	294	312	328	345	360	375	389	402	415	428	441	453	465	10.0		
10.5	128	153	178	203	227	248	268	287	304	321	336	351	365	379	393	405	418	430	442	453	10.5		
11.0	123	148	173	198	221	243	262	280	297	313	328	343	357	371	384	396	408	420	432	443	11.0		
11.5	119	144	169	194	217	237	256	274	291	306	321	336	349	362	375	387	399	411	422	433	11.5		
12.0	115	140	165	190	212	232	251	268	284	300	314	328	342	355	367	379	391	402	413	424	12.0		
12.5	111	136	161	186	208	228	246	263	279	294	308	322	335	348	360	372	383	394	405	415	12.5		
13.0	108	133	158	182	204	223	241	258	273	288	302	316	328	342	353	364	376	387	397	407	13.0		
13.5	105	130	155	179	200	219	237	253	268	283	297	310	322	335	346	358	369	379	390	400	13.5		
14.0	102	127	152	176	196	215	232	248	263	278	291	304	317	328	340	351	362	372	383	393	14.0		
14.5	99	124	149	173	193	211	228	244	259	273	286	299	311	323	334	345	356	366	376	386	14.5		
15.0	97	122	147	170	190	208	224	240	254	268	281	294	306	317	328	339	350	360	370	379	15.0		
16.0	92	117	142	164	184	201	217	232	246	260	272	284	296	307	318	328	339	348	358	367	16.0		
17.0	88	113	138	159	178	195	211	225	239	252	264	276	287	298	309	319	328	338	347	356	17.0		
18.0	85	110	134	155	173	190	205	219	232	245	257	268	279	290	300	310	319	328	337	346	18.0		
19.0	82	107	131	151	169	185	199	213	226	238	250	261	272	282	292	301	311	320	328	337	19.0		
20.0	79	104	127	147	164	180	194	208	220	232	244	254	265	275	284	294	303	312	320	328	19.0		

A = ALGEBRAIC DIFFERENCE OF GRADES IN PERCENT	WHEN S > L: $S = \frac{1079.15}{A} + \frac{L}{2}$																			WHEN S < L: $S = 46.454 \sqrt{\frac{L}{A}}$																			SD-4	
	S = SIGHT DISTANCE IN FEET																					A = ALGEBRAIC DIFFERENCE OF GRADES IN PERCENT																		
L = LENGTH OF VERTICAL CURVE IN FEET																																								
A	1050	1100	1150	1200	1250	1300	1350	1400	1450	1500	1550	1600	1650	1700	1750	1800	1850	1900	1950	2000	A																			
2.0	1065	1089	1114	1138	1161	1184	1207	1229	1251	1272	1293	1314	1334	1354	1374	1394	1413	1432	1451	1469	2.0																			
2.5	952	974	996	1018	1039	1059	1079	1099	1119	1138	1157	1175	1193	1211	1229	1246	1264	1281	1297	1314	2.5																			
3.0	869	890	910	929	948	967	985	1004	1021	1039	1056	1073	1089	1106	1122	1138	1154	1169	1184	1199	3.0																			
3.5	805	824	842	860	878	895	912	929	946	962	978	993	1009	1024	1039	1053	1068	1082	1096	1110	3.5																			
4.0	753	770	788	805	821	837	853	869	884	900	914	929	943	958	972	985	999	1012	1026	1039	4.0																			
4.5	710	726	743	759	774	790	805	819	834	848	862	876	890	903	916	929	942	955	967	979	4.5																			
5.0	673	689	705	720	735	749	763	777	791	805	818	831	844	857	869	881	894	906	917	929	5.0																			
5.5	642	657	672	686	700	714	728	741	754	767	780	792	805	817	829	840	852	863	875	886	5.5																			
6.0	615	629	643	657	671	684	697	710	722	735	747	759	770	782	793	805	816	827	837	848	6.0																			
6.5	590	604	618	631	644	657	669	682	694	706	717	729	740	751	762	773	784	794	805	815	6.5																			
7.0	569	582	595	608	621	633	645	657	669	680	691	702	713	724	735	745	755	765	775	785	7.0																			
7.5	550	563	575	588	600	612	623	635	646	657	668	679	689	699	710	720	730	739	749	759	7.5																			
8.0	532	545	557	569	581	592	603	615	625	636	647	657	667	677	687	697	706	716	725	735	8.0																			
8.5	516	528	540	552	563	574	585	596	607	617	627	637	647	657	667	676	685	695	704	713	8.5																			
9.0	502	514	525	536	547	558	569	579	590	600	610	619	629	638	648	657	666	675	684	692	9.0																			
9.5	488	500	511	522	533	543	554	564	574	584	593	603	612	621	630	639	648	657	666	674	9.5																			
10.0	476	487	498	509	519	530	540	550	559	569	578	588	597	606	615	623	632	640	649	657	10.0																			
10.5	465	475	486	497	507	517	527	536	546	555	564	573	582	591	600	608	617	625	633	641	10.5																			
11.0	454	465	475	485	495	505	515	524	533	542	551	560	569	577	586	594	602	611	619	626	11.0																			
11.5	444	454	465	475	484	494	503	513	522	531	539	548	556	565	573	581	589	597	605	613	11.5																			
12.0	435	445	455	465	474	484	493	502	511	519	528	536	545	553	561	569	577	585	592	600	12.0																			
12.5	426	436	446	455	465	474	483	492	500	509	517	526	534	542	550	557	565	573	580	588	12.5																			
13.0	417	427	437	446	456	465	473	482	491	499	507	515	523	531	539	547	554	562	569	576	13.0																			
13.5	410	419	429	438	447	456	465	473	481	490	498	506	514	521	529	536	544	551	558	565	13.5																			
14.0	402	412	421	430	439	448	456	465	473	481	489	497	504	512	519	527	534	541	548	555	14.0																			
14.5	395	405	414	423	431	440	448	456	465	472	480	488	496	503	510	518	525	532	539	546	14.5																			
15.0	389	398	407	415	424	432	441	449	457	465	472	480	487	495	502	509	516	523	530	536	15.0																			
16.0	376	385	394	402	411	419	427	435	442	450	457	465	472	479	486	493	500	506	513	519	16.0																			
17.0	365	374	382	390	398	406	414	422	429	436	444	451	458	465	471	478	485	491	498	504	17.0																			
18.0	355	363	371	379	387	395	402	410	417	424	431	438	445	451	458	465	471	477	484	490	18.0																			
19.0	345	353	361	369	377	384	392	399	406	413	420	426	433	439	446	452	458	465	471	477	19.0																			
20.0	337	345	352	360	367	375	382	389	396	402	409	415	422	428	435	441	447	453	459	465	20.0																			

STOPPING SIGHT DISTANCE ON CREST VERTICAL CURVES

HEIGHT OF EYE = 3.5 FEET

HEIGHT OF OBJECT = 2.00 FEET

VIRGINIA DEPARTMENT OF TRANSPORTATION



ROAD AND BRIDGE STANDARDS

REVISION DATE

SHEET 2 OF 2

608.07

SD-5		WHEN S>L: $S = \frac{1400}{A} + \frac{L}{2}$																			WHEN S<L: $S = 52.915 \sqrt{\frac{L}{A}}$	S = SIGHT DISTANCE IN FEET	A = ALGEBRAIC DIFFERENCE OF GRADES IN PERCENT
A = ALGEBRAIC DIFFERENCE OF GRADES IN PERCENT	L = LENGTH OF VERTICAL CURVE IN FEET																						
	50	100	150	200	250	300	350	400	450	500	550	600	650	700	750	800	850	900	950	1000			
2.0	725	750	775	800	825	850	875	900	925	950	975	1000	1025	1050	1075	1100	1125	1150	1175	1200	2.0		
2.5	585	610	635	660	685	710	735	760	785	810	835	860	885	910	935	960	985	1010	1035	1060	2.5		
3.0	492	517	542	567	592	617	642	667	692	717	742	767	792	817	842	867	892	917	942	966	3.0		
3.5	425	450	475	500	525	550	575	600	625	650	675	700	725	750	775	800	825	849	872	894	3.5		
4.0	375	400	425	450	475	500	525	550	575	600	625	650	675	700	725	748	771	794	815	837	4.0		
4.5	336	361	386	411	436	461	486	511	536	561	586	611	636	660	683	706	727	748	769	789	4.5		
5.0	305	330	355	380	405	430	455	480	505	530	555	580	603	626	648	669	690	710	729	748	5.0		
5.5	280	305	330	355	380	405	430	455	480	505	529	553	575	597	618	638	658	677	695	714	5.5		
6.0	258	283	308	333	358	383	408	433	458	483	507	529	551	572	592	611	630	648	666	683	6.0		
6.5	240	265	290	315	340	365	390	415	440	464	487	508	529	549	568	587	605	623	640	656	6.5		
7.0	225	250	275	300	325	350	375	400	424	447	469	490	510	529	548	566	583	600	616	632	7.0		
7.5	212	237	262	287	312	337	362	386	410	432	453	473	493	511	529	547	563	580	596	611	7.5		
8.0	200	225	250	275	300	325	350	374	397	418	439	458	477	495	512	529	545	561	577	592	8.0		
8.5	190	215	240	265	290	315	340	363	385	406	426	445	463	480	497	513	529	544	559	574	8.5		
9.0	181	206	231	256	281	306	330	353	374	394	414	432	450	467	483	499	514	529	544	558	9.0		
9.5	172	197	222	247	272	297	321	343	364	384	403	421	438	454	470	486	501	515	529	543	9.5		
10.0	165	190	215	240	265	290	313	335	355	374	392	410	427	443	458	473	488	502	516	529	10.0		
10.5	158	183	208	233	258	283	306	327	346	365	383	400	416	432	447	462	476	490	503	516	10.5		
11.0	152	177	202	227	252	276	298	319	338	357	374	391	407	422	437	451	465	479	492	505	11.0		
11.5	147	172	197	222	247	270	292	312	331	349	366	382	398	413	427	441	455	468	481	493	11.5		
12.0	142	167	192	217	242	265	286	306	324	342	358	374	389	404	418	432	445	458	471	483	12.0		
12.5	137	162	187	212	237	259	280	299	317	335	351	367	382	396	410	423	436	449	461	473	12.5		
13.0	133	158	183	208	232	254	275	294	311	328	344	359	374	388	402	415	428	440	452	464	13.0		
13.5	129	154	179	204	228	249	269	288	306	322	338	353	367	381	394	407	420	432	444	455	13.5		
14.0	125	150	175	200	224	245	265	283	300	316	332	346	361	374	387	400	412	424	436	447	14.0		
14.5	122	147	172	197	220	241	260	278	295	311	326	340	354	368	381	393	405	417	428	439	14.5		
15.0	118	143	168	193	216	237	256	273	290	306	320	335	348	361	374	386	398	410	421	432	15.0		
16.0	113	138	163	187	209	229	247	265	281	296	310	324	337	350	362	374	386	397	408	418	16.0		
17.0	107	132	157	181	203	222	240	257	272	287	301	314	327	340	351	363	374	385	396	406	17.0		
18.0	103	128	153	176	197	216	233	249	265	279	292	306	318	330	342	353	364	374	384	394	18.0		
19.0	99	124	149	172	192	210	227	243	258	271	285	297	309	321	332	343	354	364	374	384	19.0		
20.0	95	120	145	167	187	205	221	237	251	265	277	290	302	313	324	335	345	355	365	374	20.0		

A = ALGEBRAIC DIFFERENCE OF GRADES IN PERCENT	WHEN S > L: $S = \frac{1400}{A} + \frac{L}{2}$																			WHEN S < L: $S = 52.915 \sqrt{\frac{L}{A}}$																			SD-5	
	L = LENGTH OF VERTICAL CURVE IN FEET																				A = ALGEBRAIC DIFFERENCE OF GRADES IN PERCENT																			
	1050	1100	1150	1200	1250	1300	1350	1400	1450	1500	1550	1600	1650	1700	1750	1800	1850	1900	1950	2000	A =																			
2.0	1225	1250	1275	1300	1325	1350	1375	1400	1425	1449	1473	1497	1520	1543	1565	1587	1609	1631	1652	1673	2.0																			
2.5	1085	1100	1135	1159	1183	1207	1230	1252	1274	1296	1318	1339	1359	1380	1400	1420	1439	1459	1478	1497	2.5																			
3.0	990	1013	1036	1058	1080	1102	1122	1143	1163	1183	1203	1222	1241	1260	1278	1296	1314	1332	1349	1366	3.0																			
3.5	917	938	959	980	1000	1020	1039	1058	1077	1095	1114	1131	1149	1166	1183	1200	1217	1233	1249	1265	3.5																			
4.0	857	877	897	917	935	954	972	990	1007	1025	1042	1058	1075	1091	1107	1122	1138	1153	1168	1183	4.0																			
4.5	808	827	846	864	882	899	917	933	950	966	982	998	1013	1028	1043	1058	1073	1087	1102	1116	4.5																			
5.0	767	785	802	820	837	853	869	885	901	917	932	947	961	976	990	1004	1018	1032	1045	1058	5.0																			
5.5	731	748	765	782	798	814	829	844	859	874	888	903	917	930	944	957	970	983	996	1009	5.5																			
6.0	700	716	733	748	764	779	794	808	823	837	850	864	877	891	904	917	929	942	954	966	6.0																			
6.5	673	688	704	719	734	748	763	777	790	804	817	830	843	856	868	881	893	905	917	928	6.5																			
7.0	648	663	678	693	707	721	735	748	762	775	787	800	812	825	837	849	860	872	883	894	7.0																			
7.5	626	641	655	669	683	697	710	723	736	748	761	773	785	797	808	820	831	842	853	864	7.5																			
8.0	606	620	634	648	661	675	687	700	712	725	737	748	760	771	783	794	805	815	826	837	8.0																			
8.5	588	602	615	629	642	654	667	679	691	703	715	726	737	748	759	770	781	791	801	812	8.5																			
9.0	572	585	598	611	624	636	648	660	672	683	694	706	716	727	738	748	759	769	779	789	9.0																			
9.5	556	569	582	595	607	619	631	642	654	665	676	687	697	708	718	728	738	748	758	768	9.5																			
10.0	542	555	567	580	592	603	615	626	637	648	659	669	680	690	700	710	720	729	739	748	10.0																			
10.5	529	542	554	566	577	589	600	611	622	632	643	653	663	673	683	693	702	712	721	730	10.5																			
11.0	517	529	541	553	564	575	586	597	608	618	628	638	648	658	667	677	686	695	705	714	11.0																			
11.5	506	518	529	541	552	563	573	584	594	604	614	624	634	643	653	662	671	680	689	698	11.5																			
12.0	495	507	518	529	540	551	561	572	582	592	601	611	620	630	639	648	657	666	675	683	12.0																			
12.5	485	496	508	518	529	540	550	560	570	580	589	599	608	617	626	635	644	652	661	669	12.5																			
13.0	476	487	498	508	519	529	539	549	559	568	578	587	596	605	614	623	631	640	648	656	13.0																			
13.5	467	478	488	499	509	519	529	539	548	558	567	576	585	594	602	611	619	628	636	644	13.5																			
14.0	458	469	480	490	500	510	520	529	539	548	557	566	574	583	592	600	608	616	624	632	14.0																			
14.5	450	461	471	481	491	501	511	520	529	538	547	556	564	573	581	590	598	606	614	621	14.5																			
15.0	443	453	463	473	483	493	502	511	520	529	538	547	555	563	572	580	588	596	603	611	15.0																			
16.0	429	439	449	458	468	477	486	495	504	512	521	529	537	545	553	561	569	577	584	592	16.0																			
17.0	416	426	435	445	454	463	472	480	489	497	505	513	521	529	537	544	552	559	567	574	17.0																			
18.0	404	414	423	432	441	450	458	467	475	483	491	499	507	514	522	529	536	544	551	558	18.0																			
19.0	393	403	412	421	429	438	446	454	462	470	478	486	493	501	508	515	522	529	536	543	19.0																			
20.0	383	392	401	410	418	427	435	443	451	458	466	473	481	488	495	502	509	516	522	529	20.0																			

PASSING SIGHT DISTANCE ON CREST VERTICAL CURVES

HEIGHT OF EYE = 3.5 FEET

HEIGHT OF OBJECT = 3.5 FEET

VIRGINIA DEPARTMENT OF TRANSPORTATION



ROAD AND BRIDGE STANDARDS

REVISION DATE

SHEET 2 OF 2

608.09

THIS PAGE INTENTIONALLY LEFT BLANK



ROAD AND BRIDGE STANDARDS

SHEET 1 OF 1

REVISION DATE

608.10

VIRGINIA DEPARTMENT OF TRANSPORTATION

SPECIFICATION
REFERENCE

SECTION 700

GEOMETRIC DESIGNS

THIS PAGE INTENTIONALLY LEFT BLANK



ROAD AND BRIDGE STANDARDS

SHEET 1 OF 1

REVISION DATE

SPECIFICATION
REFERENCE

VIRGINIA DEPARTMENT OF TRANSPORTATION

STANDARD	TITLE	PAGE
CS-1, 1A	TYPICAL METHODS OF GRADING SIDE SLOPES	701.01
CS-2	SUGGESTED DRAINAGE TREATMENT AT BEGINNING OF FILLS	701.02
CS-2A	TYPICAL METHODS OF GRADING SIDE SLOPES	701.03
CS-3	TYPICAL METHODS OF GRADING SIDE SLOPES	701.04
CS-3A	TYPICAL METHODS OF GRADING SIDE SLOPES	701.05
CS-3B	TYPICAL METHODS OF GRADING SIDE SLOPES	701.06
CS-4	TYPICAL METHODS OF GRADING SIDE SLOPES	701.07
CS-4A	TYPICAL METHODS OF GRADING SIDE SLOPES	701.08
CS-4B	TYPICAL METHODS OF GRADING SIDE SLOPES	701.09
CS-4C	TYPICAL METHODS OF GRADING SIDE SLOPES	701.10
CS-4E	TYPICAL METHODS OF GRADING SIDE SLOPES	701.11
GS-10	MINIMUM DESIGN CRITERIA FOR TEMPORARY DETOURS (MOT)	SEE VDOT'S ROAD DESIGN MANUAL FOR GS STANDARDS VOID
GS-11	STANDARD SHOULDER DESIGN FOR ALL SYSTEMS EXCEPT LOCAL ROADS AND STREETS	SEE VDOT'S ROAD DESIGN MANUAL FOR GS STANDARDS VOID
GS-12	STANDARD SHOULDER DESIGN FOR LOCAL ROADS AND STREETS	SEE VDOT'S ROAD DESIGN MANUAL FOR GS STANDARDS VOID
GS-13	STANDARD GRADED MEDIAN DESIGNS	SEE VDOT'S ROAD DESIGN MANUAL FOR GS STANDARDS VOID

INDEX OF SHEETS
SECTION 700-GEOMETRIC DESIGN

VIRGINIA DEPARTMENT OF TRANSPORTATION



ROAD AND BRIDGE STANDARDS

REVISION DATE

SHEET 1 OF 1

7/12

700.01

THIS PAGE INTENTIONALLY LEFT BLANK



ROAD AND BRIDGE STANDARDS

SHEET 1 OF 1

REVISION DATE

700.02

VIRGINIA DEPARTMENT OF TRANSPORTATION

SPECIFICATION
REFERENCE

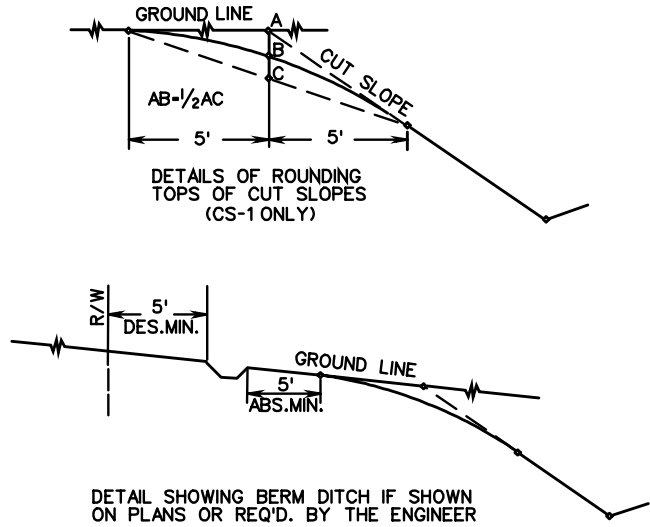

NOTES:

SLOPE ROUNDING (STD. CS-1) TO BE AS DETAILED ABOVE, UNLESS SPECIFICALLY EXCEPTED ON PROJECT TYPICAL SECTION(S).

SEE STANDARD CS-2A FOR SUGGESTED METHODS OF FINISHING SLOPES TO FIT VARIOUS CONDITIONS.

SEE STANDARD CS-2 FOR SUGGESTED METHOD OF TRANSITIONING FROM CUT TO FILL.

ALL SLOPES SHALL BE FINISHED IN ACCORDANCE WITH THIS PLAN AND NOTES HEREON. EXCEPTIONS: LACK OF RIGHT OF WAY, ROCK OUT-CROP, OR WHERE DESIRABLE TO SAVE TREES, SHRUBBERY, ETC., AS MAY BE DIRECTED BY THE ENGINEER. SHOULD THIS RESULT IN SURPLUS EXCAVATION MATERIAL, SUCH SURPLUS SHALL BE USED AS DIRECTED BY THE ENGINEER, IN LIEU OF BORROW, TO WIDEN FILLS, OR GRADE WITHIN THE RIGHT OF WAY. SHOULD IT RESULT IN INSUFFICIENT EXCAVATION MATERIAL, SUCH MATERIAL SHALL BE OBTAINED AS DIRECTED BY THE ENGINEER.

WHEN FOUND EXPEDIENT, STANDARD DITCH WIDTH AND DEPTH MAY BE INCREASED; THE DISTANCE BETWEEN BOTTOM OF DITCH AND MINIMUM RIGHT OF WAY LINE TO REMAIN AS SHOWN FOR STANDARD DITCH.

IN SHALLOW CUTS, WHERE POSSIBLE, KEEP THE CUT SLOPE, AT LEAST AS STEEP AS THE DITCH SLOPE BY WIDENING THE DITCH, HOLDING THE STANDARD DEPTH.

ST'D. CS-1: AS DETAILED HEREON WITH CUT SLOPE ROUNDING.
ST'D. CS-1A: AS DETAILED HEREON EXCEPT THAT CUT SLOPE ROUNDING IS TO BE ELIMINATED.

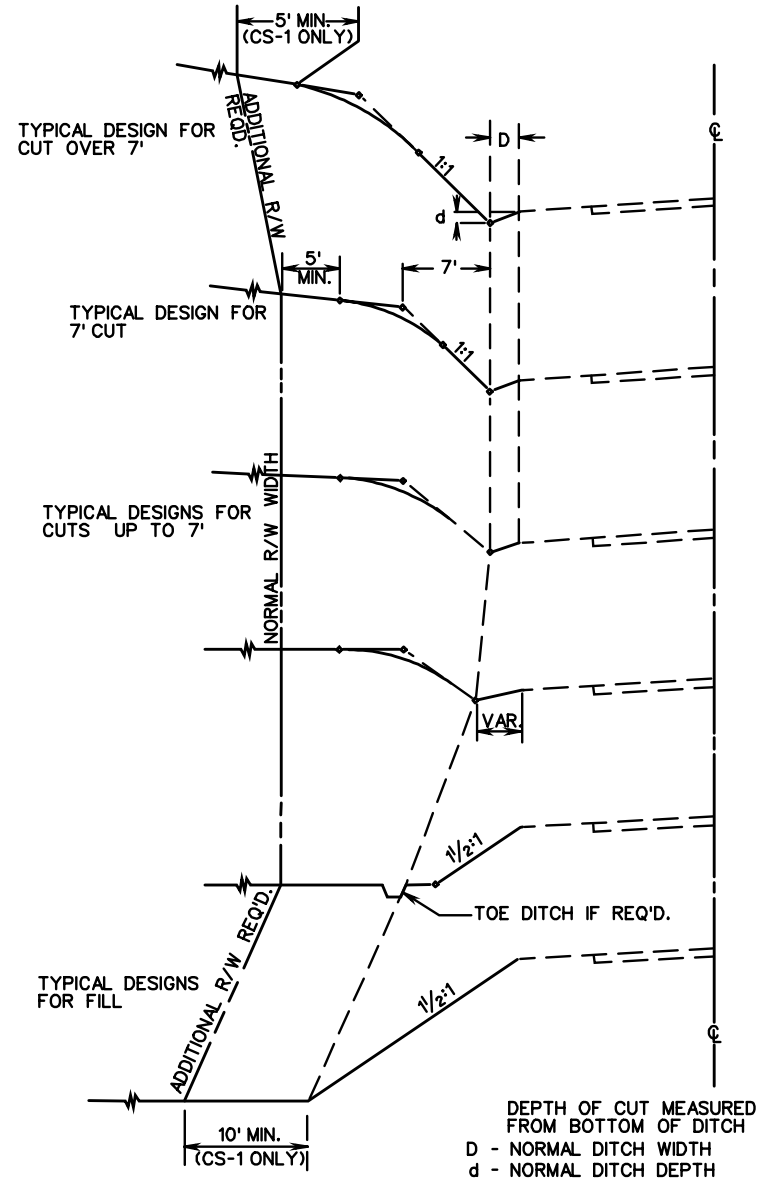

SPECIFICATION REFERENCE
303

TYPICAL METHODS OF GRADING SIDE SLOPES

VIRGINIA DEPARTMENT OF TRANSPORTATION

VDOT	
ROAD AND BRIDGE STANDARDS	
REVISION DATE	SHEET 1 OF 1
	701.01

SUGGESTIONS FOR GRADING SIDE SLOPES AND ROADWAYS TO FIT VARIOUS CONDITIONS

APPLICABLE TO ALL SLOPES AND SLOPE STANDARDS

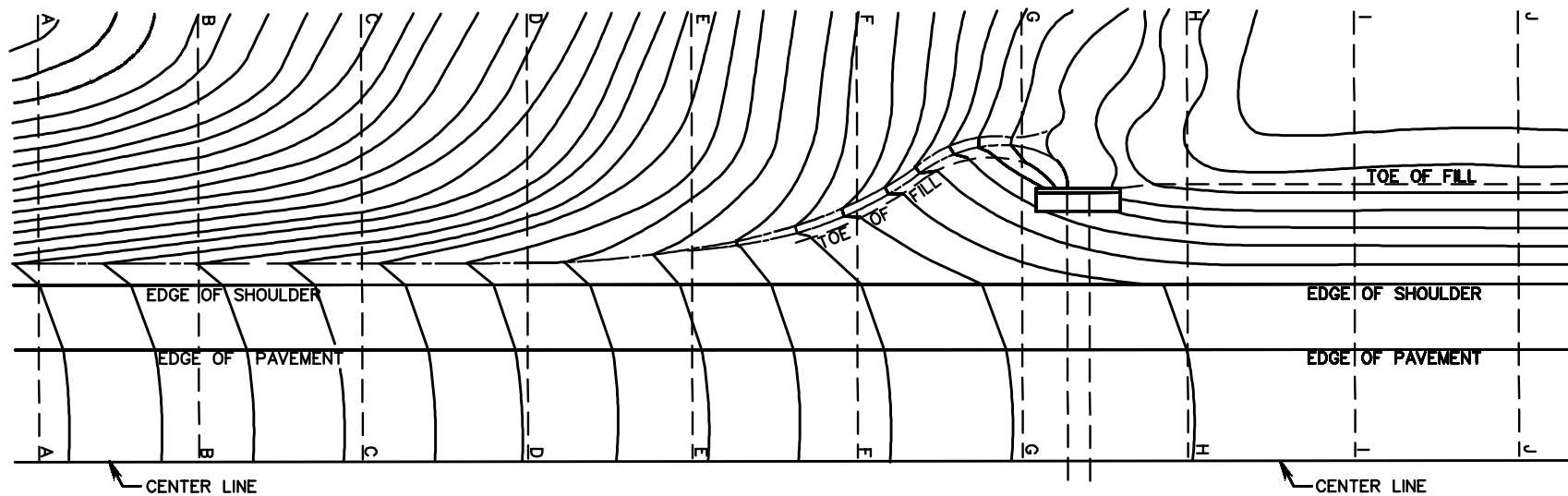
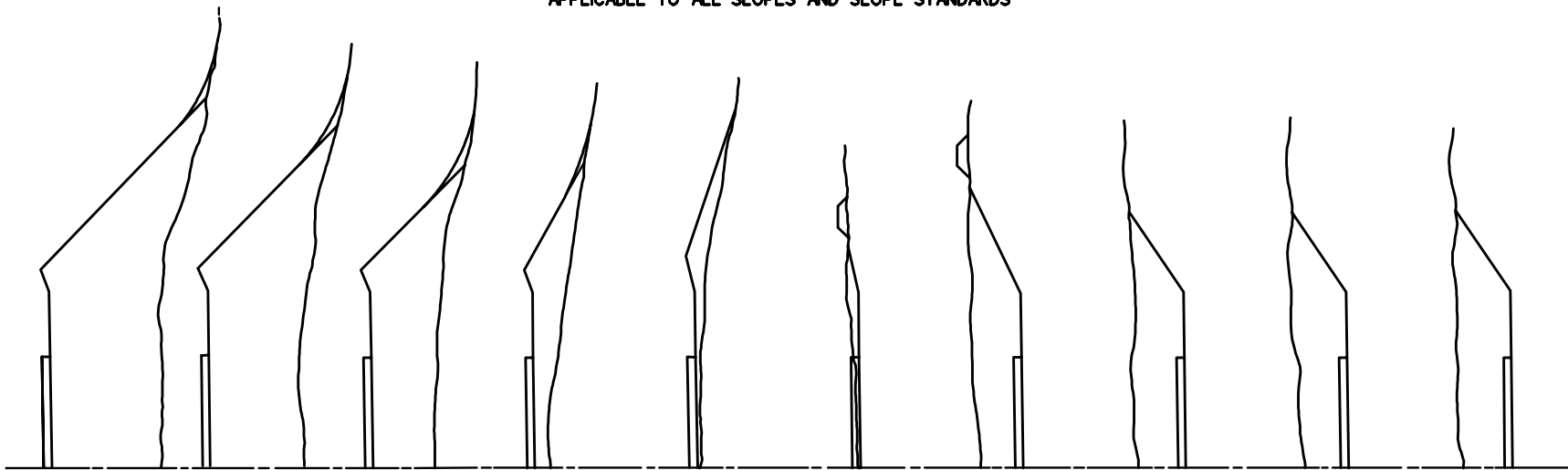

ROAD AND BRIDGE STANDARDS

SHEET 1 OF 1

REVISION DATE

701.02

SUGGESTED DRAINAGE TREATMENT

(AT BEGINNING OF FILLS)

VIRGINIA DEPARTMENT OF TRANSPORTATION

SPECIFICATION REFERENCE

303

SUGGESTIONS FOR GRADING SIDE SLOPES AND ROADWAYS TO FIT VARIOUS CONDITIONS

APPLICABLE TO ALL SLOPES AND SLOPE STANDARDS

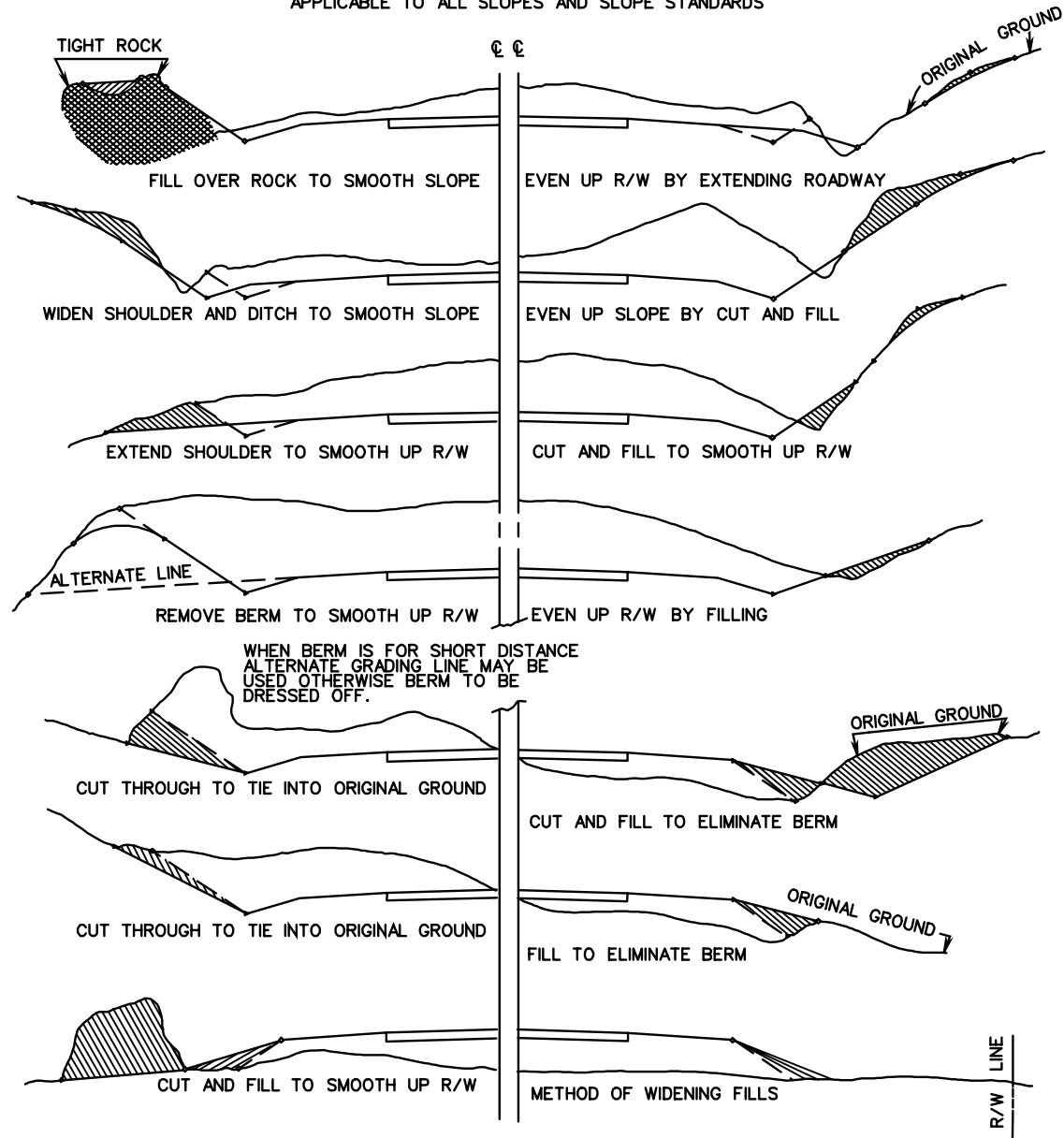

SPECIFICATION REFERENCE

303

TYPICAL METHODS OF GRADING SIDE SLOPES

VIRGINIA DEPARTMENT OF TRANSPORTATION

VDOT

ROAD AND BRIDGE STANDARDS

REVISION DATE

SHEET 1 OF 1

701.03

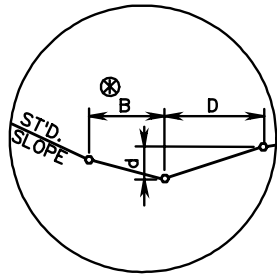

DETAIL A

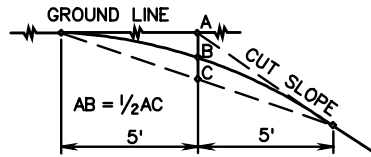

DETAILS OF ROUNDING TOPS OF CUT SLOPES

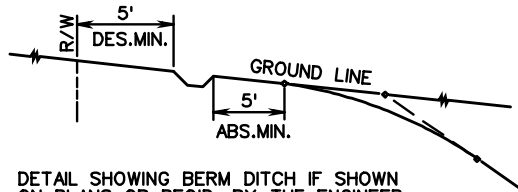

DETAIL SHOWING BERM DITCH IF SHOWN ON PLANS OR REQ'D. BY THE ENGINEER

NOTES:

SLOPE ROUNDING TO BE IN ACCORDANCE WITH ABOVE DETAIL UNLESS SPECIFICALLY EXCEPTED ON PROJECT TYPICAL SECTION(S).

SEE STANDARD CS-2A FOR SUGGESTED METHODS OF FINISHING SLOPES TO FIT VARIOUS CONDITIONS.

SEE STANDARD CS-2 FOR SUGGESTED METHOD OF TRANSITIONING FROM CUT TO FILL.

ALL SLOPES SHALL BE FINISHED IN ACCORDANCE WITH THIS PLAN AND NOTES HEREON. EXCEPTIONS: LACK OF RIGHT OF WAY, ROCK OUT-CROP, OR WHERE DESIRABLE TO SAVE TREES, SHRUBBERY, ETC., AS MAY BE DIRECTED BY THE ENGINEER. SHOULD THIS RESULT IN SURPLUS EXCAVATION MATERIAL, SUCH SURPLUS SHALL BE USED AS DIRECTED BY THE ENGINEER, IN LIEU OF BORROW, TO WIDEN FILLS, OR GRADE WITHIN THE RIGHT OF WAY. SHOULD IT RESULT IN INSUFFICIENT EXCAVATION MATERIAL, SUCH MATERIAL SHALL BE OBTAINED AS DIRECTED BY THE ENGINEER.

IN SHALLOW CUTS, WHERE POSSIBLE, KEEP THE CUT SLOPE AT LEAST AS STEEP AS THE DITCH SLOPE BY WIDENING THE DITCH, HOLDING THE STANDARD DEPTH.

MAXIMUM SLOPE RATE SHALL NOT BE CHANGED MORE THAN TWICE IN A CUT.

IF METHOD SHOWN FOR TRANSITIONING FROM 1/2:1 SLOPES AND VICE VERSA, PRODUCES TRANSITIONS TOO SHORT, THEY SHALL BE INCREASED TO 100' IN LENGTH.

WHEN RECOVERABLE AREAS ARE NOT INDICATED ON THE TYPICAL SECTION, THE FILL SLOPE IS TO BE APPLIED TO THE NORMAL SHOULDER WIDTH BREAK POINT.

⊗ SEE TYPICAL SECTION FOR DITCH WIDTH.

* SEE TYPICAL SECTION FOR RECOVERABLE AREA WIDTH TO BE USED WITH NORMAL FILL SHOULDER WIDTH.

WHEN FOUND EXPEDIENT, STANDARD DITCH WIDTH AND DEPTH MAY BE INCREASED. THE DISTANCE BETWEEN BOTTOM OF DITCH AND MINIMUM OF RIGHT OF WAY LINE TO REMAIN AS SHOWN FOR STANDARD DITCH.

IN CUTS UP 400' IN LENGTH 1/2:1 SLOPES MAY BE CARRIED THROUGH REGARDLESS OF DEPTH, PROVIDED RIGHT OF WAY IS AVAILABLE.

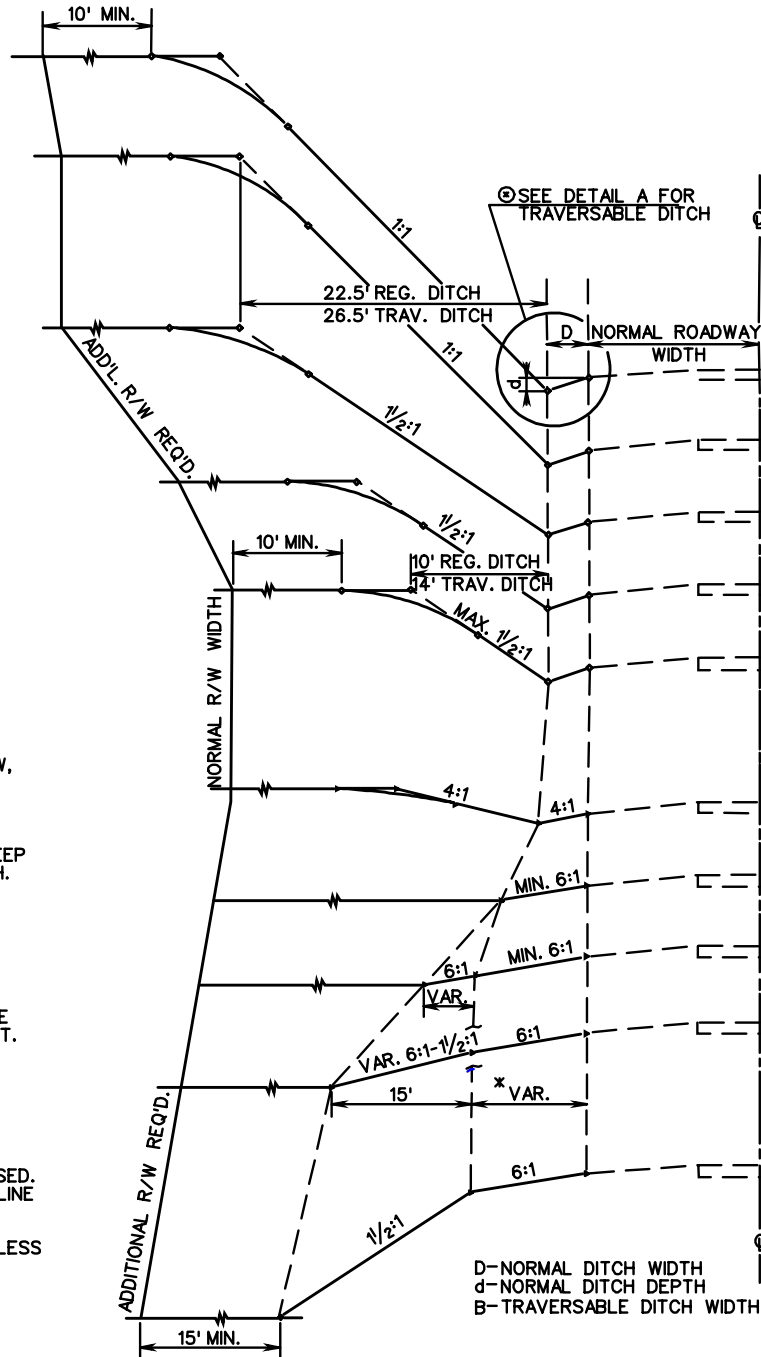

ROAD AND BRIDGE STANDARDS

SHEET 1 OF 1

REVISION DATE

701.04

TYPICAL METHODS OF GRADING SIDE SLOPES

VIRGINIA DEPARTMENT OF TRANSPORTATION

SPECIFICATION REFERENCE

303

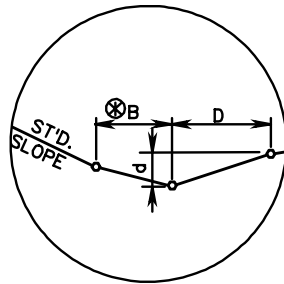

DETAIL A

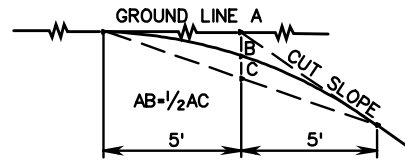

DETAILS OF ROUNDING TOPS OF CUT SLOPES

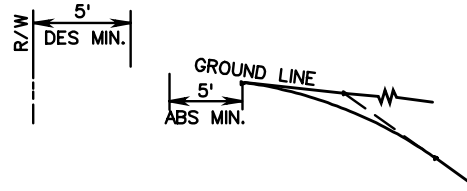

DETAIL SHOWING BERM DITCH IF SHOWN ON PLANS OR REQ'D BY THE ENGINEER

NOTES:

SLOPE ROUNDING TO BE IN ACCORDANCE WITH ABOVE DETAIL UNLESS SPECIFICALLY EXCEPTED ON PROJECT TYPICAL SECTION(S).

SEE STANDARD CS-2A FOR SUGGESTED METHODS OF FINISHING SLOPES TO FIT VARIOUS CONDITIONS.

SEE STANDARD CS-2 FOR SUGGESTED METHOD OF TRANSITIONING FROM CUT TO FILL.

ALL SLOPES SHALL BE FINISHED IN ACCORDANCE WITH THIS PLAN AND NOTES HEREON. EXCEPTIONS: LACK OF RIGHT OF WAY, ROCK OUT-CROP, OR WHERE DESIRABLE TO SAVE TREES, SHRUBBERY, ETC., AS MAY BE DIRECTED BY THE ENGINEER. SHOULD THIS RESULT IN SURPLUS EXCAVATION MATERIAL, SUCH SURPLUS SHALL BE USED AS DIRECTED BY THE ENGINEER, IN LIEU OF BORROW, TO WIDEN FILLS, OR GRADE WITHIN THE RIGHT OF WAY. SHOULD IT RESULT IN INSUFFICIENT EXCAVATION MATERIAL, SUCH MATERIAL SHALL BE OBTAINED AS DIRECTED BY THE ENGINEER.

WHEN FOUND EXPEDIENT, STANDARD DITCH WIDTH AND DEPTH MAY BE INCREASED; THE DISTANCE BETWEEN BOTTOM OF DITCH AND MINIMUM RIGHT OF WAY LINE TO REMAIN AS SHOWN FOR STANDARD DITCH.

IN SHALLOW CUTS, WHERE POSSIBLE, KEEP THE CUT SLOPE AT LEAST AS STEEP AS THE DITCH SLOPE BY WIDENING THE DITCH, HOLDING THE STANDARD DEPTH.

WHEN RECOVERABLE AREAS ARE NOT INDICATED ON THE TYPICAL SECTION, THE FILL SLOPE IS TO BE APPLIED TO THE NORMAL SHOULDER WIDTH BREAK POINT.

⊗ SEE TYPICAL SECTION FOR TRAVERSABLE DITCH WIDTH AND SLOPE.

* SEE TYPICAL SECTION FOR RECOVERABLE AREA WIDTH TO BE USED WITH NORMAL FILL SHOULDER WIDTH.

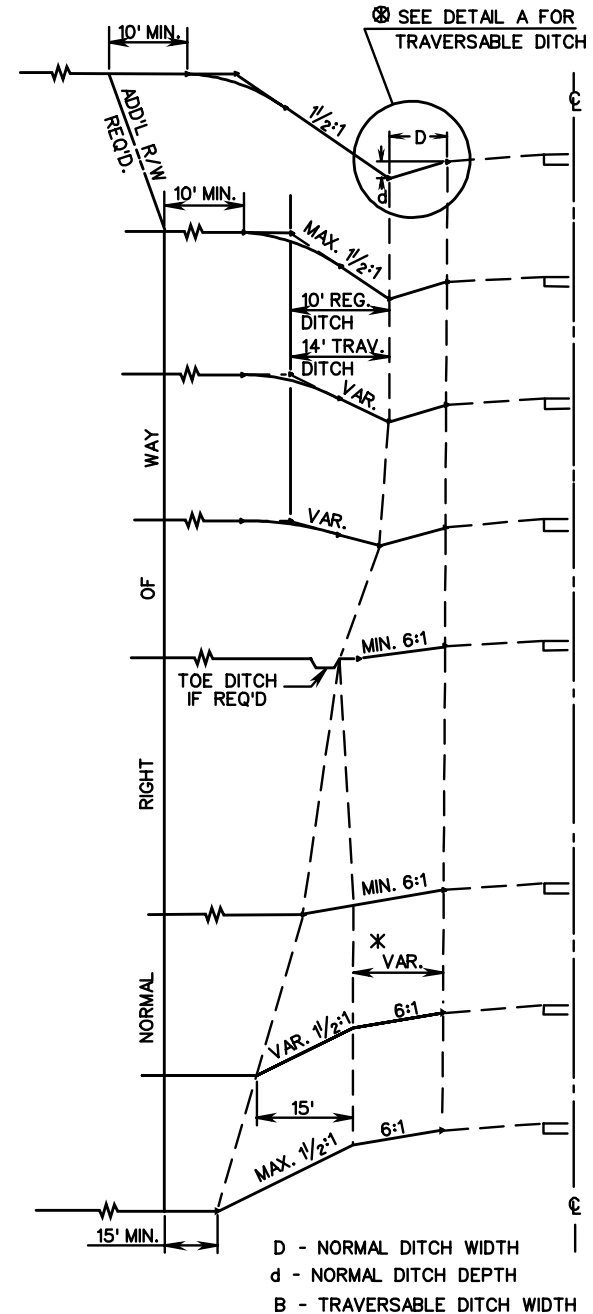

SPECIFICATION REFERENCE

303

TYPICAL METHODS OF GRADING SIDE SLOPES

VIRGINIA DEPARTMENT OF TRANSPORTATION

VDOT

ROAD AND BRIDGE STANDARDS

REVISION DATE

SHEET 1 OF 1

701.05

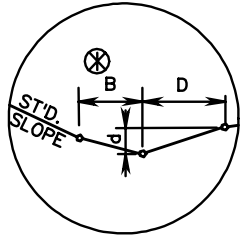

DETAIL A

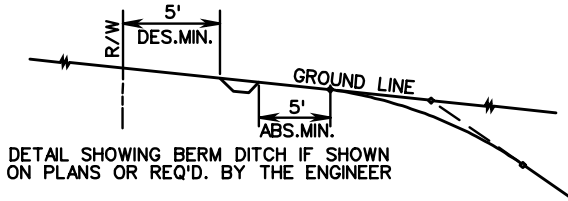
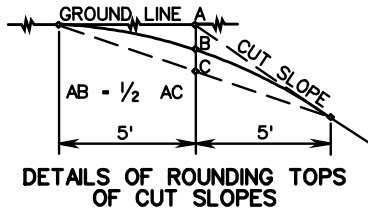

NOTES:

SLOPE ROUNDING TO BE IN ACCORDANCE WITH ABOVE DETAIL UNLESS SPECIFICALLY EXCEPTED ON PROJECT TYPICAL SECTION(S).

SEE STANDARD CS-2A FOR SUGGESTED METHODS OF FINISHING SLOPES TO FIT VARIOUS CONDITIONS.

SEE STANDARD CS-2 FOR SUGGESTED METHOD OF TRANSITIONING FROM CUT TO FILL.

ALL SLOPES SHALL BE FINISHED IN ACCORDANCE WITH THIS PLAN AND NOTES HEREON. EXCEPTIONS: LACK OF RIGHT OF WAY, ROCK OUT-CROP, OR WHERE DESIRABLE TO SAVE TREES, SHRUBBERY, ETC., AS MAY BE DIRECTED BY THE ENGINEER. SHOULD THIS RESULT IN SURPLUS EXCAVATION MATERIAL, SUCH SURPLUS SHALL BE USED AS DIRECTED BY THE ENGINEER, IN LIEU OF BORROW, TO WIDEN FILLS, OR GRADE WITHIN THE RIGHT OF WAY. SHOULD IT RESULT IN INSUFFICIENT EXCAVATION MATERIAL, SUCH MATERIAL SHALL BE OBTAINED AS DIRECTED BY THE ENGINEER.

WHEN FOUND EXPEDIENT, STANDARD DITCH WIDTH AND DEPTH MAY BE INCREASED; THE DISTANCE BETWEEN BOTTOM OF DITCH AND MINIMUM RIGHT OF WAY LINE TO REMAIN AS SHOWN FOR STANDARD DITCH.

IN SHALLOW CUTS, WHERE POSSIBLE, KEEP THE CUT SLOPE AT LEAST AS STEEP AS THE DITCH SLOPE BY WIDENING THE DITCH, HOLDING THE STANDARD DEPTH.

IN CUTS UP TO 400' IN LENGTH 1/2:1 SLOPES MAY BE CARRIED THROUGH REGARDLESS OF DEPTH, PROVIDED RIGHT OF WAY IS AVAILABLE.

MAXIMUM SLOPE RATE SHALL NOT BE CHANGED MORE THAN TWICE IN A CUT.

IF METHOD SHOWN FOR TRANSITIONING FROM 1/2:1 TO 1:1 SLOPES AND VICE VERSA PRODUCES TRANSITIONS TOO SHORT, THEY SHALL BE INCREASED TO 100' IN LENGTH.

WHEN RECOVERABLE AREAS ARE NOT INDICATED ON THE TYPICAL SECTION, THE FILL SLOPE IS TO BE APPLIED TO THE NORMAL SHOULDER WIDTH BREAK POINT.

⊗ SEE TYPICAL SECTION FOR DITCH WIDTH

* SEE TYPICAL SECTION FOR RECOVERABLE AREA WIDTH TO BE USED WITH NORMAL FILL SHOULDER WIDTH

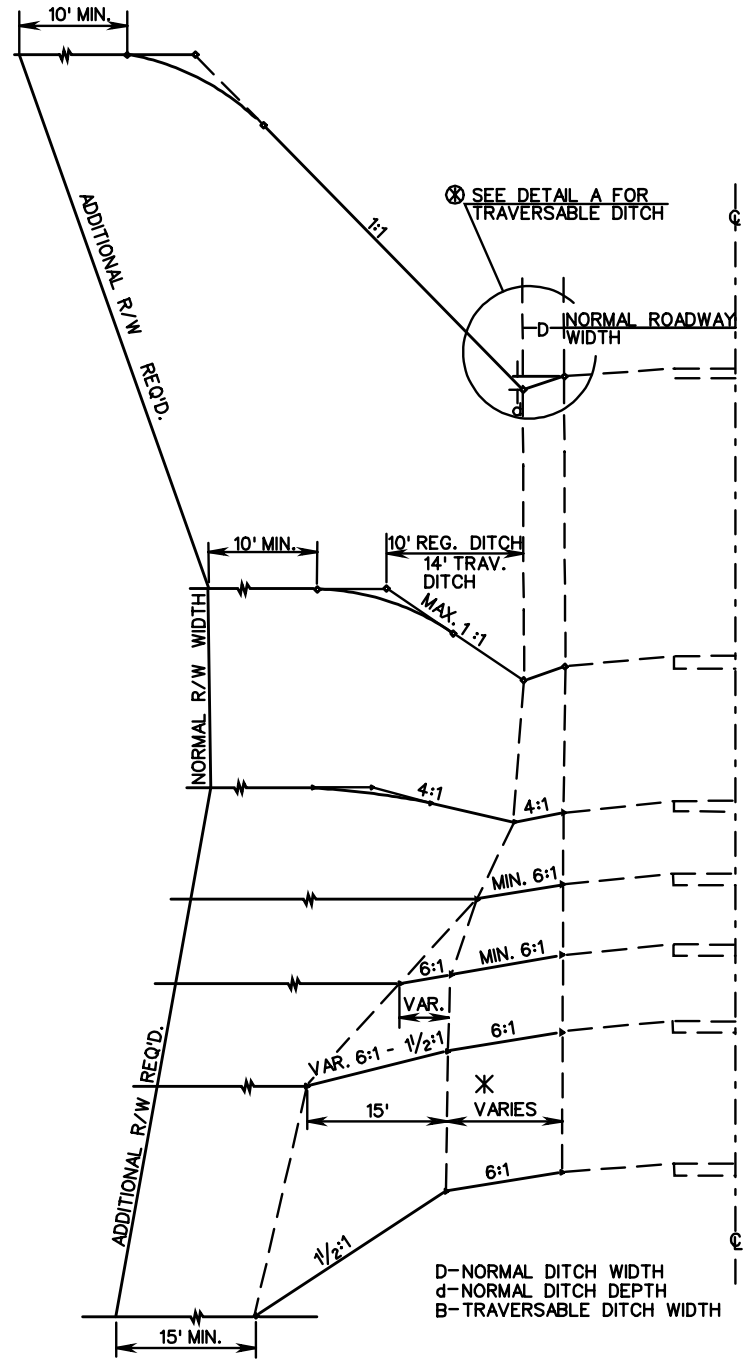

ROAD AND BRIDGE STANDARDS

SHEET 1 OF 1

REVISION DATE

701.06

TYPICAL METHODS OF GRADING SIDE SLOPES

VIRGINIA DEPARTMENT OF TRANSPORTATION

SPECIFICATION REFERENCE

303

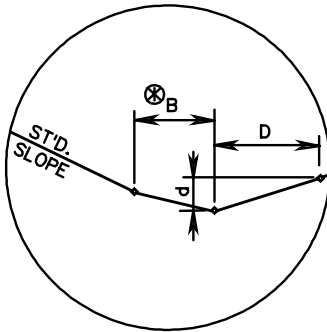

DETAIL A

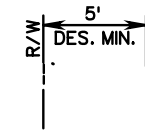
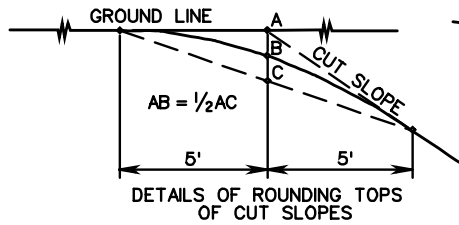

DETAIL SHOWING BERM DITCH IF SHOWN ON PLANS OR REQ'D. BY THE ENGINEER

NOTES:

SLOPE ROUNDING TO BE IN ACCORDANCE WITH ABOVE DETAIL UNLESS SPECIFICALLY EXCEPTED ON PROJECT TYPICAL SECTION(S).

SEE STANDARD CS-2A FOR SUGGESTED METHODS OF FINISHING SLOPES TO FIT VARIOUS CONDITIONS.

SEE STANDARD CS-2 FOR SUGGESTED METHOD OF TRANTIONING FROM CUT TO FILL.

ALL SLOPES SHALL BE FINISHED IN ACCORDANCE WITH THIS PLAN AND NOTES HEREON. EXCEPTIONS: LACK OF RIGHT OF WAY, ROCK OUT-CROP, OR WHERE DESIRABLE TO SAVE TREES, SHRUBBERY, ETC., AS MAY BE DIRECTED BY THE ENGINEER. SHOULD THIS RESULT IN SURPLUS EXCAVATION MATERIAL, SUCH SURPLUS SHALL BE USED AS DIRECTED BY THE ENGINEER, IN LIEU OF BORROW, TO WIDEN FILLS, OR GRADE WITHIN THE RIGHT OF WAY. SHOULD IT RESULT IN INSUFFICIENT EXCAVATION MATERIAL, SUCH MATERIAL SHALL BE OBTAINED AS DIRECTED BY THE ENGINEER.

WHEN FOUND EXPEDIENT, STANDARD DITCH WIDTH AND DEPTH MAY BE INCREASED; THE DISTANCE BETWEEN BOTTOM OF DITCH AND MINIMUM RIGHT OF WAY LINE TO REMAIN AS SHOWN FOR STANDARD DITCH.

IN SHALLOW CUTS, WHERE POSSIBLE, KEEP THE CUT SLOPE AT LEAST AS STEEP AS THE DITCH SLOPE BY WIDENING THE DITCH, HOLDING THE STANDARD DEPTH.

WHEN RECOVERABLE AREAS ARE NOT INDICATED ON THE TYPICAL SECTION, THE FILL SLOPE IS TO BE APPLIED TO NORMAL SHOULDER WIDTH BREAK POINT.

⊗ SEE TYPICAL SECTION FOR TRAVERSABLE DITCH WIDTH AND SLOPE.

* SEE TYPICAL SECTION FOR RECOVERABLE AREA WIDTH TO BE USED WITH NORMAL FILL SHOULDER WIDTH.

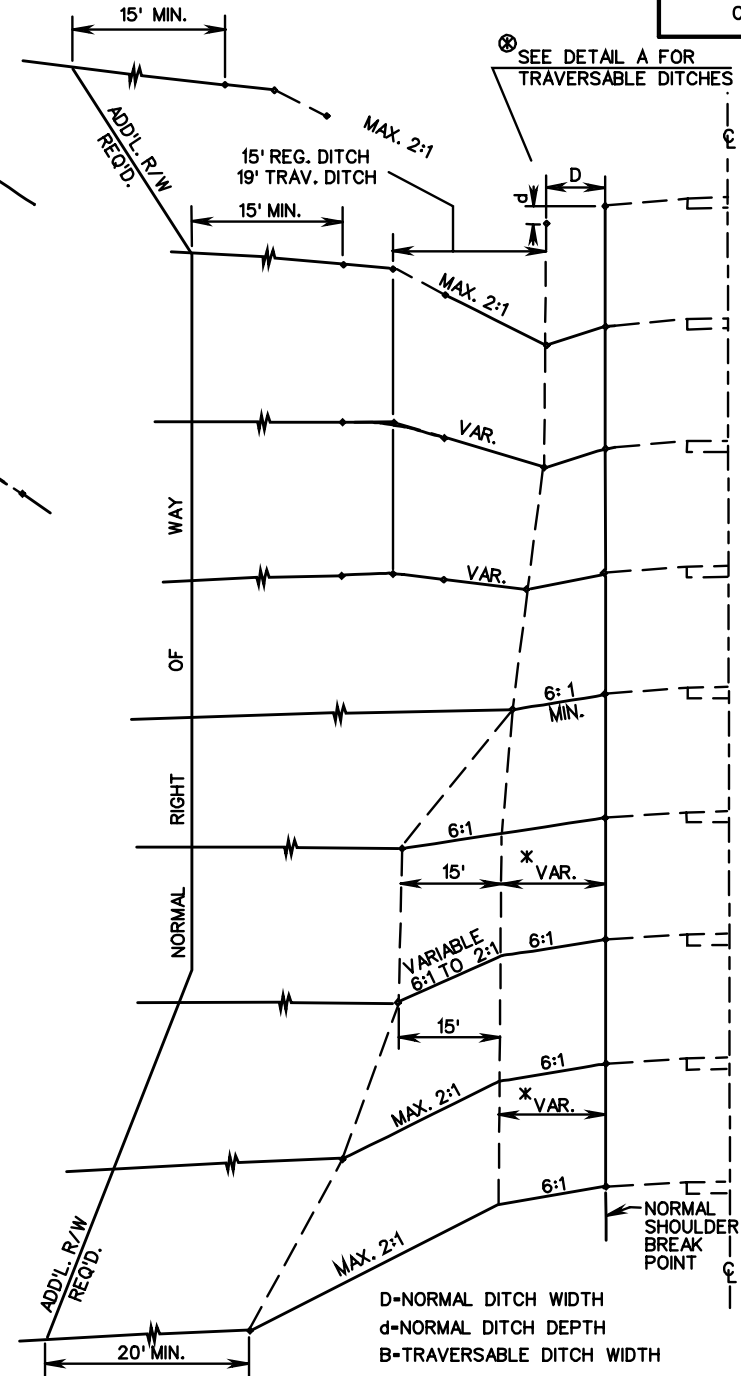

SPECIFICATION REFERENCE

303

TYPICAL METHODS OF GRADING SIDE SLOPES

VIRGINIA DEPARTMENT OF TRANSPORTATION

VDOT

ROAD AND BRIDGE STANDARDS

REVISION DATE

SHEET 1 OF 1

701.07

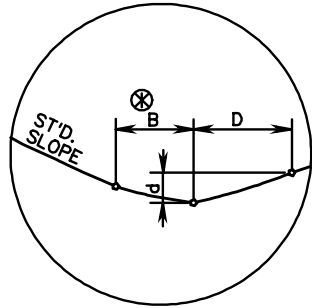

DETAIL A

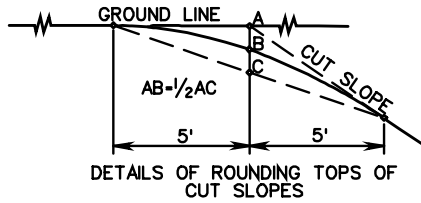

DETAILS OF ROUNDING TOPS OF CUT SLOPES

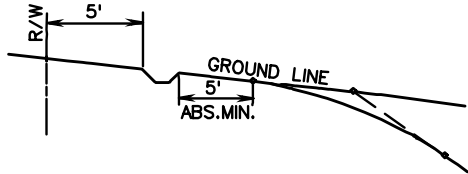

DETAIL SHOWING BERM DITCH IF SHOWN ON PLANS OR REQ'D. BY THE ENGINEER

NOTES:

SLOPE ROUNDING TO BE IN ACCORDANCE WITH ABOVE DETAIL UNLESS SPECIFICALLY EXCEPTED ON PROJECT TYPICAL SECTION(S).

SEE STANDARD CS-2A FOR SUGGESTED METHODS OF FINISHING SLOPES TO FIT VARIOUS CONDITIONS.

SEE STANDARD CS-2 FOR SUGGESTED METHODS OF TRANSITIONING FROM CUT TO FILL.

ALL SLOPES SHALL BE FINISHED IN ACCORDANCE WITH THIS PLAN AND NOTES HEREON. EXCEPTIONS: LACK OF RIGHT OF WAY, ROCK OUT-CROP, OR WHERE DESIRABLE TO SAVE TREES, SHRUBBERY, ETC., AS MAY BE DIRECTED BY THE ENGINEER. SHOULD THIS RESULT IN SURPLUS EXCAVATION MATERIAL, SUCH SURPLUS SHALL BE USED AS DIRECTED BY THE ENGINEER, IN LIEU OF BORROW, TO WIDEN FILLS, OR GRADE WITHIN THE RIGHT OF WAY. SHOULD IT RESULT IN INSUFFICIENT EXCAVATION MATERIAL, SUCH MATERIAL SHALL BE OBTAINED AS DIRECTED BY THE ENGINEER.

WHEN FOUND EXPEDIENT, STANDARD DITCH WIDTH AND DEPTH MAY BE INCREASED; THE DISTANCE BETWEEN BOTTOM OF DITCH AND MINIMUM RIGHT OF WAY LINE TO REMAIN AS SHOWN FOR STANDARD DITCH.

IN SHALLOW CUTS, WHERE POSSIBLE, KEEP THE CUT SLOPE AT LEAST AS STEEP AS THE DITCH SLOPE BY WIDENING THE DITCH, HOLDING THE STANDARD DEPTH.

IN CUTS UP TO 400' IN LENGTH 1/2:1 SLOPES MAY BE CARRIED THROUGH REGARDLESS OF DEPTH, PROVIDED RIGHT OF WAY IS AVAILABLE.

MAXIMUM SLOPE RATE SHALL NOT BE CHANGED MORE THAN TWICE IN A CUT. IF METHOD SHOWN FOR TRANSITIONING FROM 2:1 TO 1/2:1 SLOPES AND VICE VERSA PRODUCES TRANSITIONS TOO SHORT, THEY SHALL BE INCREASED TO 100' IN LENGTH.

* SEE TYPICAL SECTIONS FOR RECOVERABLE AREA WIDTH WHEN RECOVERABLE AREAS ARE NOT INDICATED ON THE TYPICAL SECTION, THE FILL SLOPE IS TO BE APPLIED TO THE NORMAL SHOULDER WIDTH BREAK POINT.

⊗ SEE TYPICAL SECTION FOR TRAVERSABLE DITCH WIDTH AND SLOPE.

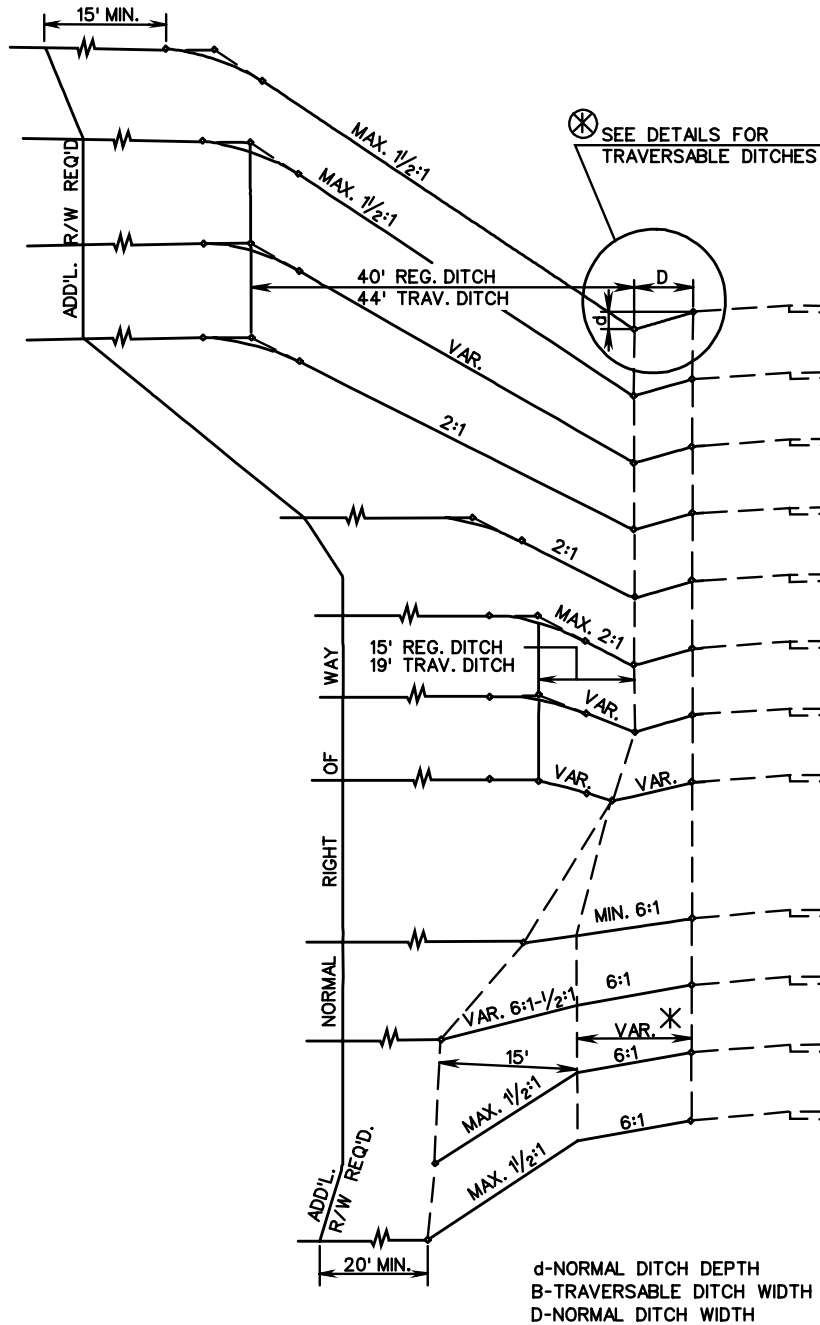

d-NORMAL DITCH DEPTH
B-TRAVERSABLE DITCH WIDTH
D-NORMAL DITCH WIDTH



ROAD AND BRIDGE STANDARDS

TYPICAL METHODS OF GRADING SIDE SLOPES

SPECIFICATION REFERENCE

SHEET 1 OF 1

REVISION DATE

303

701.08

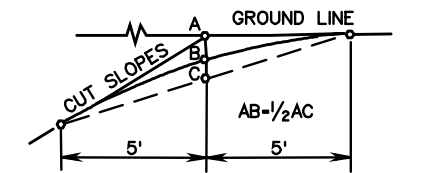
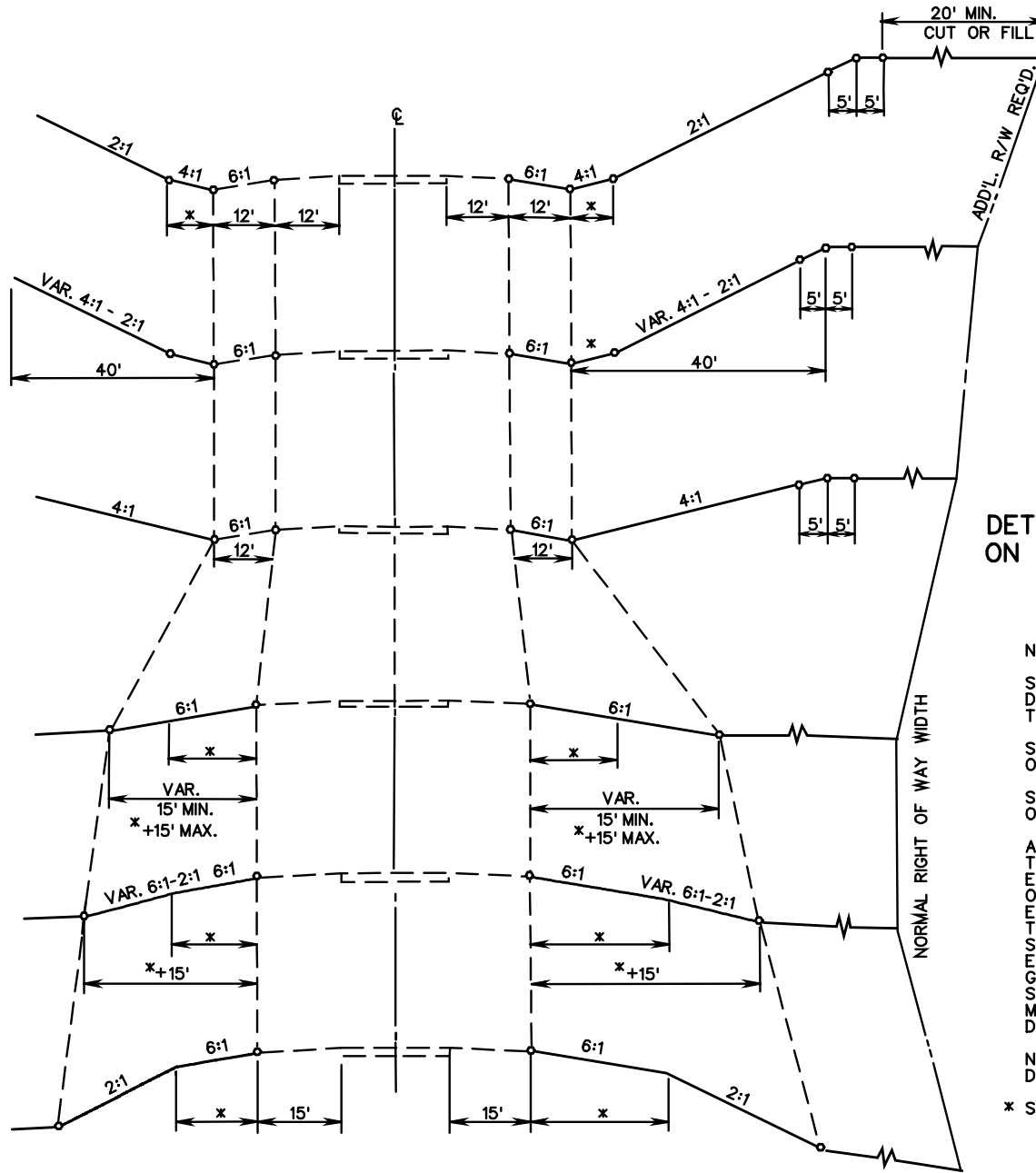

DETAIL OF ROUNDING TOPS OF CUT SLOPES

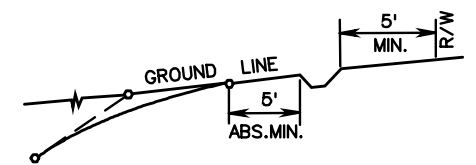

DETAIL SHOWING BERM DITCH IF SHOWN ON PLANS OR REQ'D. BY THE ENGINEER

NOTES:

SLOPE ROUNDING TO BE IN ACCORDANCE WITH ABOVE DETAIL UNLESS SPECIFICALLY EXCEPTED ON PROJECT TYPICAL SECTION(S).

SEE STANDARD CS-2A FOR SUGGESTED METHODS OF FINISHING SLOPES TO FIT VARIOUS CONDITIONS.

SEE STANDARD CS-2 FOR SUGGESTED METHOD OF TRANSITIONING FROM CUT TO FILL.

ALL SLOPES SHALL BE FINISHED IN ACCORDANCE WITH THIS PLAN AND NOTES HEREON. EXCEPTIONS: LACK OF RIGHT OF WAY, ROCK OUT-CROP OR WHERE DESIRABLE TO SAVE TREES, SHRUBBERY, ETC., AS MAY BE DIRECTED BY THE ENGINEER. SHOULD THIS RESULT IN SURPLUS EXCAVATION MATERIAL, SUCH SURPLUS SHALL BE USED AS DIRECTED BY THE ENGINEER, IN LEIU OF BORROW, TO WIDEN FILLS, OR GRADE WITHIN THE RIGHT OF WAY. SHOULD IT RESULT IN INSUFFICIENT EXCAVATION MATERIAL, SUCH MATERIAL SHALL BE OBTAINED AS DIRECTED BY THE ENGINEER.

NORMAL GUARDRAIL OFFSET TO BE AS SHOWN FOR DETAILS OF TRANSITIONING SEE ST'D. GR-INS.

* SEE TYPICAL SECTION FOR RECOVERABLE AREA WIDTH.

SPECIFICATION REFERENCE
303

TYPICAL METHODS OF GRADING SIDE SLOPES

VIRGINIA DEPARTMENT OF TRANSPORTATION

VDOT	
ROAD AND BRIDGE STANDARDS	
REVISION DATE	SHEET 1 OF 1
	701.09

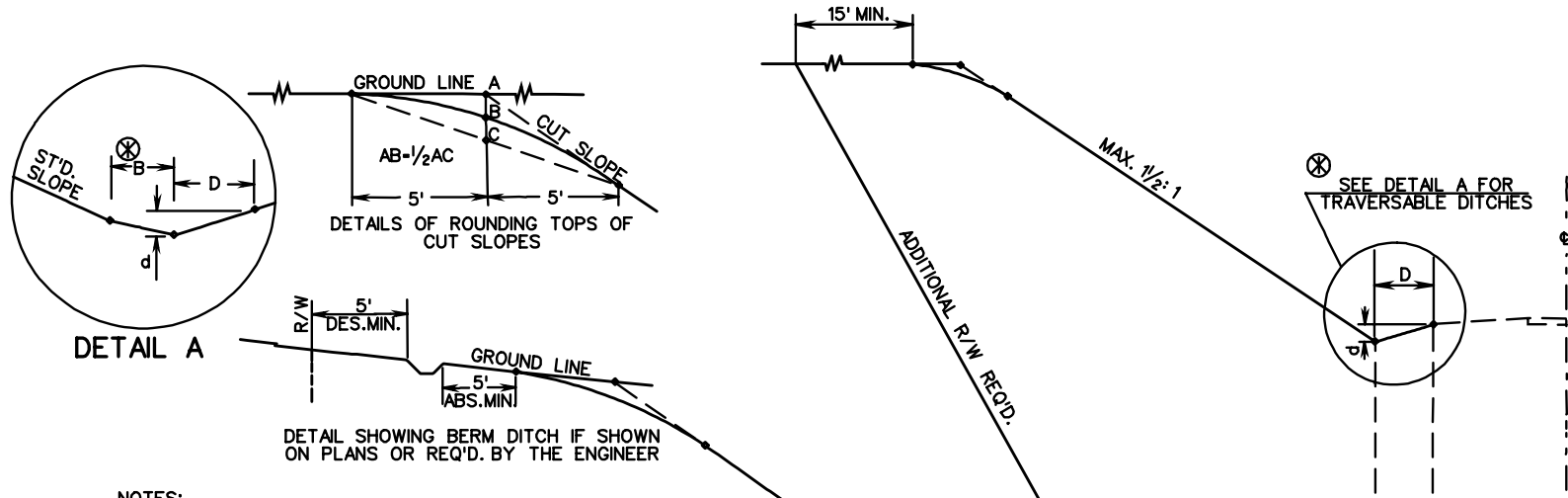

NOTES:
 SLOPE ROUNDING TO BE IN ACCORDANCE WITH ABOVE DETAIL UNLESS SPECIFICALLY EXCEPTED ON PROJECT TYPICAL SECTION(S).
 SEE STANDARD CS-2A FOR SUGGESTED METHODS OF FINISHING SLOPES TO FIT VARIOUS CONDITIONS.
 SEE STANDARD CS-2 FOR SUGGESTED METHOD OF TRANSITIONING FROM CUT TO FILL.
 ALL SLOPES SHALL BE FINISHED IN ACCORDANCE WITH THIS PLAN AND NOTES HEREON. EXCEPTIONS: LACK OF RIGHT OF WAY, ROCK OUT-CROP, OR WHERE DESIRABLE TO SAVE TREES, SHRUBBERY, ETC., AS MAY BE DIRECTED BY THE ENGINEER. SHOULD THIS RESULT IN SURPLUS EXCAVATION MATERIAL, SUCH SURPLUS SHALL BE USED AS DIRECTED BY THE ENGINEER, IN LIEU OF BORROW, TO WIDEN FILLS, OR GRADE WITHIN THE RIGHT OF WAY. SHOULD IT RESULT IN INSUFFICIENT EXCAVATION MATERIAL, SUCH MATERIAL SHALL BE OBTAINED AS DIRECTED BY THE ENGINEER.
 WHEN FOUND EXPEDIENT, STANDARD DITCH WIDTH AND DEPTH MAY BE INCREASED; THE DISTANCE BETWEEN BOTTOM OF DITCH AND MINIMUM RIGHT OF WAY LINE TO REMAIN AS SHOWN FOR STANDARD DITCH.
 IN SHALLOW CUTS, WHERE POSSIBLE, KEEP THE CUT SLOPE AT LEAST AS STEEP AS THE DITCH SLOPE BY WIDENING THE DITCH, HOLDING THE STANDARD DEPTH.
 IN CUTS UP TO 400' IN LENGTH 1/2:1 SLOPES MAY BE CARRIED THROUGH REGARDLESS OF DEPTH, PROVIDED RIGHT OF WAY IS AVAILABLE.
 MAXIMUM SLOPE RATE SHALL NOT BE CHANGED MORE THAN TWICE IN A CUT.
 IF METHOD SHOWN FOR TRANSITIONING FROM 1/2:1 TO 1:1 SLOPES AND VICE VERSA PRODUCES TRANSITIONS TOO SHORT, THEY SHALL BE INCREASED TO 100' IN LENGTH.
 * SEE TYPICAL SECTION FOR RECOVERABLE AREA WIDTH WHEN RECOVERABLE AREAS ARE NOT INDICATED ON THE TYPICAL SECTION, THE FILL SLOPE IS TO BE APPLIED TO THE NORMAL SHOULDER WIDTH BREAK POINT.
 ⊗ SEE TYPICAL SECTION FOR TRAVERSABLE DITCH WIDTH AND SLOPE.

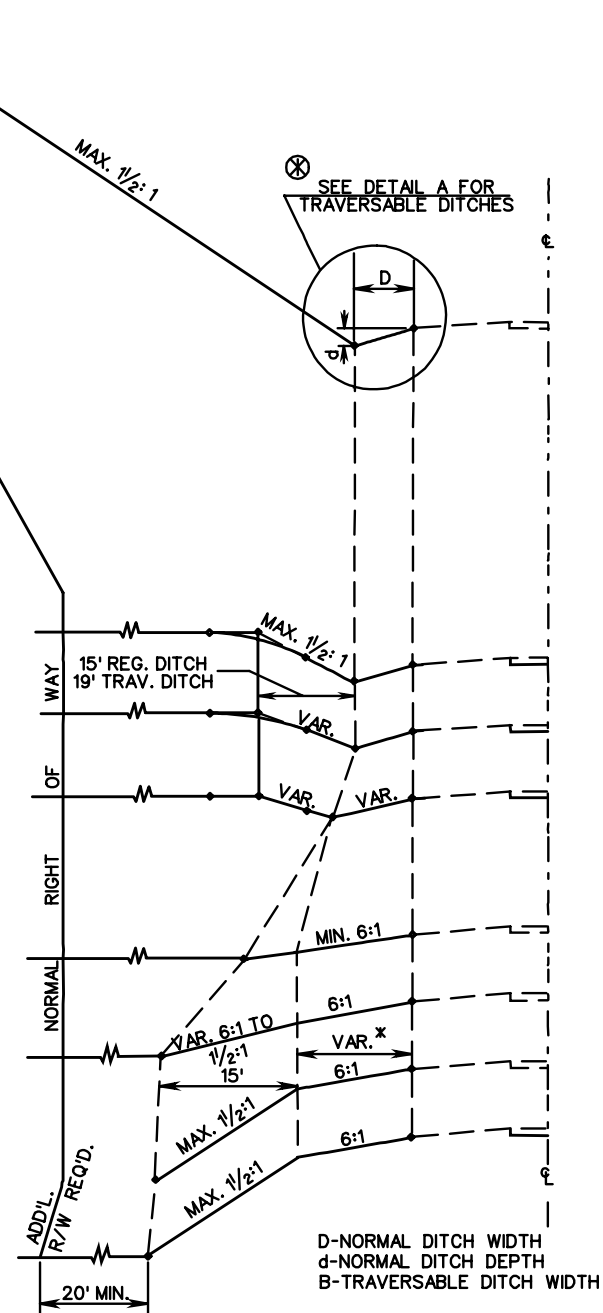

VDOT	
ROAD AND BRIDGE STANDARDS	
SHEET 1 OF 1	REVISION DATE
701.10	

TYPICAL METHODS OF GRADING SIDE SLOPES

SPECIFICATION REFERENCE
303

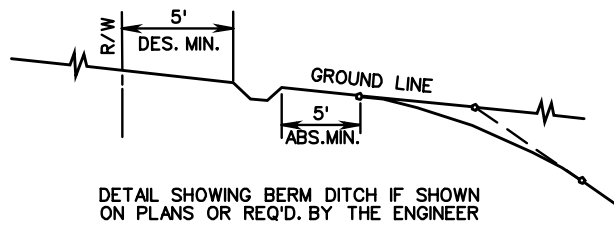
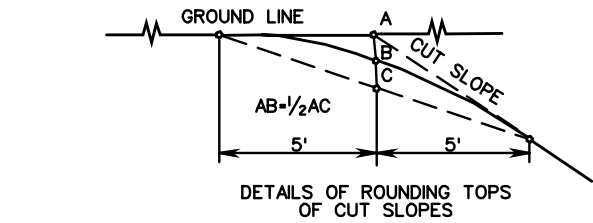

NOTES:

SLOPE ROUNDING TO BE AS DETAILED ABOVE, UNLESS SPECIFICALLY EXCEPTED ON PROJECT TYPICAL SECTION(S).

SEE STANDARD CS-2A FOR SUGGESTED METHODS OF FINISHING SLOPES TO FIT VARIOUS CONDITIONS.

SEE STANDARD CS-2 FOR SUGGESTED METHOD OF TRANSITIONING FROM CUT TO FILL.

ALL SLOPES SHALL BE FINISHED IN ACCORDANCE WITH THIS PLAN AND NOTES HEREON. EXCEPTIONS: LACK OF RIGHT OF WAY, ROCK OUT-CROP, OR WHERE DESIRABLE TO SAVE TREES, SHRUBBERY, ETC., AS MAY BE DIRECTED BY THE ENGINEER. SHOULD THIS RESULT IN SURPLUS SHALL BE USED AS DIRECTED BY THE ENGINEER, IN LIEU OF BORROW, TO WIDEN FILLS, OR GRADE WITHIN THE RIGHT OF WAY. SHOULD IT RESULT IN INSUFFICIENT EXCAVATION MATERIAL, SUCH MATERIAL SHALL BE OBTAINED AS DIRECTED BY THE ENGINEER.

* SEE TYPICAL SECTION FOR RECOVERABLE AREA WIDTH TO BE USED WITH NORMAL FILL SHOULDER WIDTH.

WHEN RECOVERABLE AREAS ARE NOT INDICATED ON THE TYPICAL SECTION, THE FILL SLOPE IS TO BE APPLIED TO THE NORMAL SHOULDER WIDTH BREAK POINT.

⊗ SEE TYPICAL SECTION FOR TRAVERSABLE DITCH WIDTH AND SLOPE.

SEE STANDARD PLAN GS-13 FOR GRADED MEDIAN.

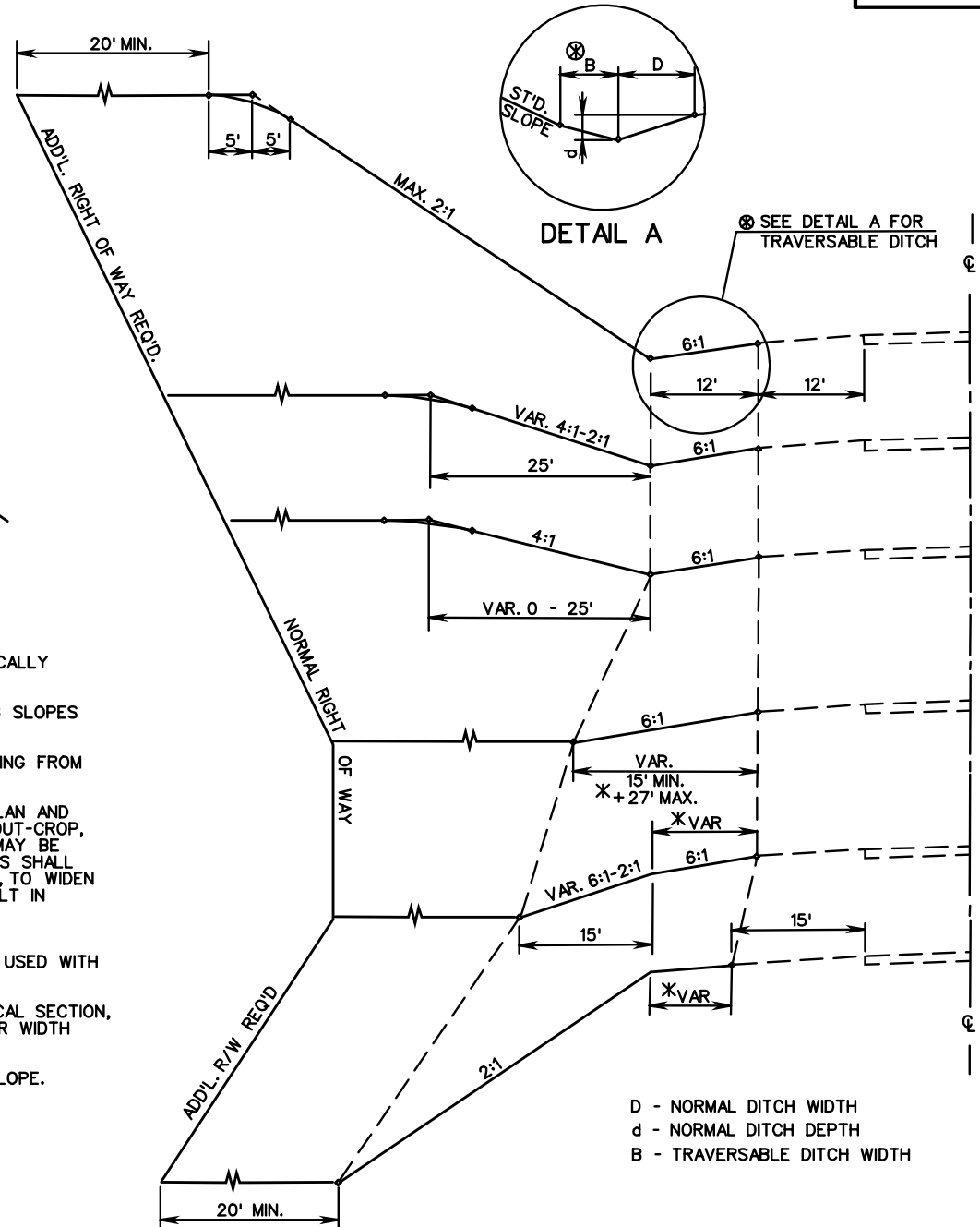

SPECIFICATION REFERENCE
303

TYPICAL METHODS OF GRADING SIDE SLOPES

VIRGINIA DEPARTMENT OF TRANSPORTATION

VDOT ROAD AND BRIDGE STANDARDS	
REVISION DATE	SHEET 1 OF 1
701.11	

THIS PAGE INTENTIONALLY LEFT BLANK



ROAD AND BRIDGE STANDARDS

SHEET 1 OF 1

REVISION DATE

701.12

VIRGINIA DEPARTMENT OF TRANSPORTATION

SPECIFICATION
REFERENCE

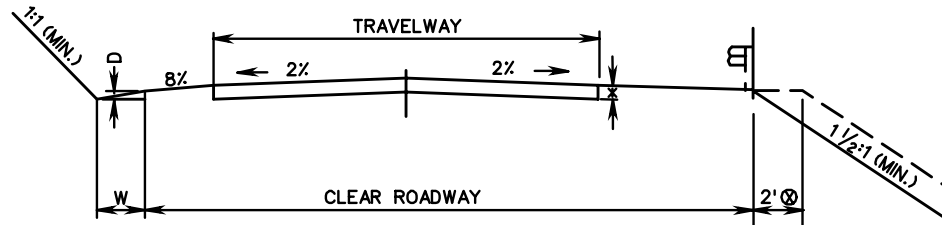

* SEE PLANS FOR BASE DEPTH AND TYPE AND PAVED SURFACE TREATMENT WHERE REQUIRED.

TYPICAL SECTION

⊗ FOR GUARDRAIL:
ADD 2' TO 4' SHOULDERS
ADD 3' TO ALL OTHER SHOULDERS

BRIDGE WIDTH = APPROACH ROADWAY WIDTH (CLEAR ROADWAY).

WIDTHS FOR TWO WAY TRAFFIC
(LESSER WIDTH MAY BE USED FOR ONE-WAY)

TYPE	CURRENT ADT	* TRAVELWAY WIDTH	SURFACE		MIN. ROADWAY SHOULDER TO SHOULDER ⊗	DITCH WIDTH (W)	DITCH DEPTH (D)	PAY ITEM
			UNPAVED	PAVED				
A	0-250	18'	✓		22'	4'	16"	LF.
B	251-750	20'	✓		24' ABS. 30' DES.	4'	16"	LF.
C	751-2000	22'		✓	30' ABS. 34' DES.	4'	16"	* *
D	2001-5500	24'		✓	40'	4'	16"	* *
E	5501-15,000	24'		✓	40'	4'	16"	* *
F	15,000-ABOVE	24'		✓	40'	6'	18"	* *

* CURVES TO BE WIDENED IN ACCORDANCE WITH ST'D. TC-5.01R.
** PAID FOR BY INDIVIDUAL QUANTITIES.

GEOMETRICS

DESIGN SPEED M.P.H.	20	30	40	50	60	70
MIN. RADII	108' R	251' R	465' R	760' R	1204' R	1821' R
MAX. % GRADE	DES.	8%	7%	7%	6%	5%
	ABS.	16%	14%	13%	10%	6%
STOPPING SIGHT DISTANCE	DES.	125'	200'	325'	475'	650'
	MIN.			305'	425'	570'
MAXIMUM SUPERELEVATION	8%	8%	8%	8%	8%	8%

IF GEOMETRICS AND WIDTHS SHOWN IN THESE CHARTS ARE GREATER THAN THE FINISHED CONTRACT DESIGN, APPROVAL MAY BE GRANTED BY THE DEPARTMENT FOR LESSER VALUES.

SPECIFICATION REFERENCE

510

MINIMUM DESIGN CRITERIA FOR TEMPORARY DETOURS
(MAINTENANCE OF TRAFFIC)

VIRGINIA DEPARTMENT OF TRANSPORTATION

VDOT

ROAD AND BRIDGE STANDARDS

REVISION DATE

SHEET 1 OF 1

702.01

GRADED MEDIAN SHOULDERS

OUTSIDE SHOULDERS

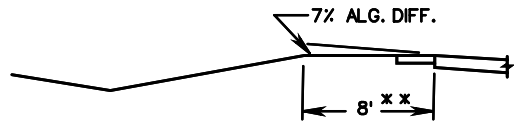

** WHERE MAINLINE IS 6 OR MORE LANES GRADED SHOULDER WIDTH IS TO BE THE SAME AS THAT SHOWN FOR FILL SHOULDER FOR INDEPENDENT GRADING.

HIGH SIDE - SUPERELEVATED

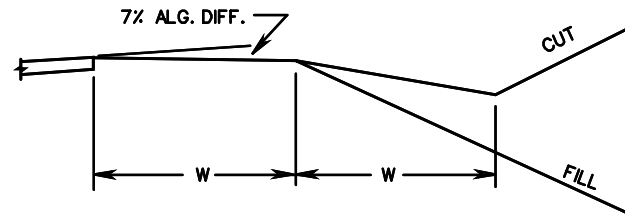

HIGH SIDE - SUPERELEVATED

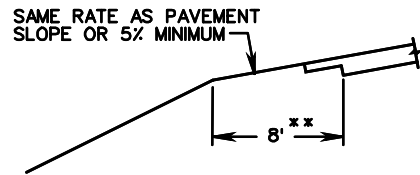

LOW SIDE - SUPERELEVATED

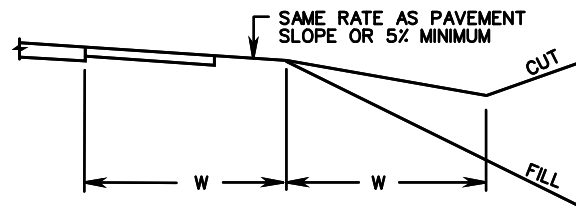

LOW SIDE - SUPERELEVATED

NOTE: FOR WIDTH OF SHOULDERS AND DITCHES (W) SEE GEOMETRIC DESIGN STANDARDS.



ROAD AND BRIDGE STANDARDS

SHEET 1 OF 1

REVISION DATE

702.02

STANDARD SHOULDER DESIGN FOR ALL SYSTEMS EXCEPT LOCAL ROADS AND STREETS

VIRGINIA DEPARTMENT OF TRANSPORTATION

TANGENT SECTION

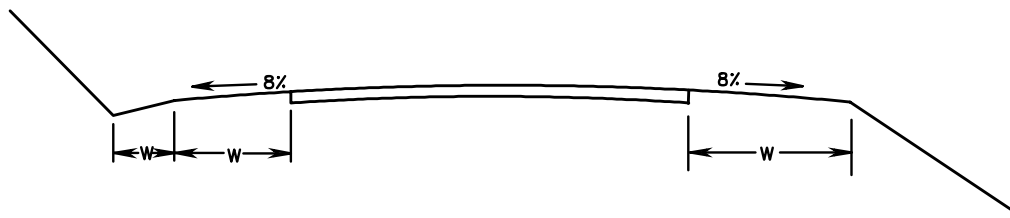

FOR WIDTHS OF SHOULDERS AND DITCHES (W)
SEE STANDARDS..

SUPERELEVATED SECTION

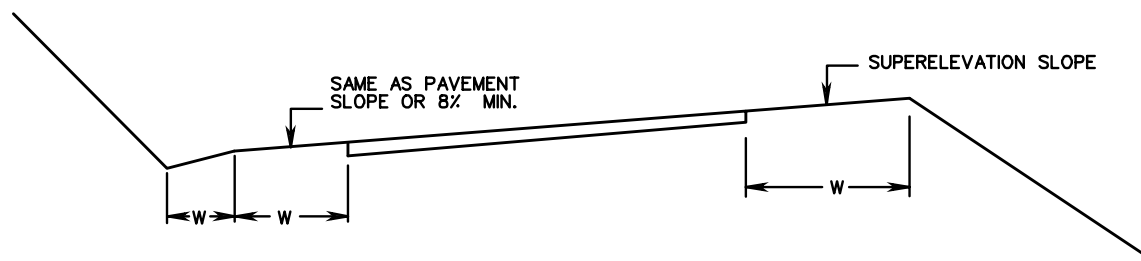

FOR WIDTHS OF SHOULDERS AND DITCHES (W)
SEE STANDARDS.

SPECIFICATION
REFERENCE

STANDARD SHOULDER DESIGN FOR LOCAL ROADS & STREETS

VIRGINIA DEPARTMENT OF TRANSPORTATION

VDOT

ROAD AND BRIDGE STANDARDS

REVISION DATE

SHEET 1 OF 1

702.03

MEDIAN EDGES OF SHOULDER AT SAME OR APPROXIMATELY SAME ELEVATION

(GRADING TO CENTER OF MEDIAN)

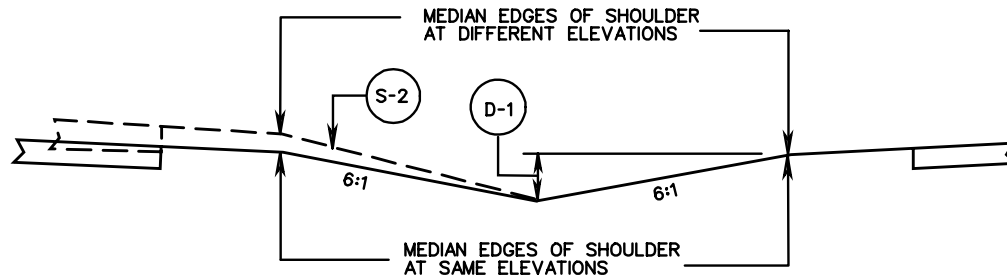

(D-1) VARIABLE DEPTH
(2' MIN.)

(S-2) VARIABLE SLOPE

HOLD A 6:1 SLOPE FROM THE EDGES OF MEDIAN SHOULDERS
(FROM THE LOWER MEDIAN SHOULDER IF AT DIFFERENT ELEVATIONS)
TO THE CENTER OF MEDIAN.

MEDIAN EDGES OF SHOULDER AT DIFFERENT ELEVATIONS

(GRADING FROM HIGH SHOULDER TO DITCH ADJACENT TO LOWER ROADWAY)

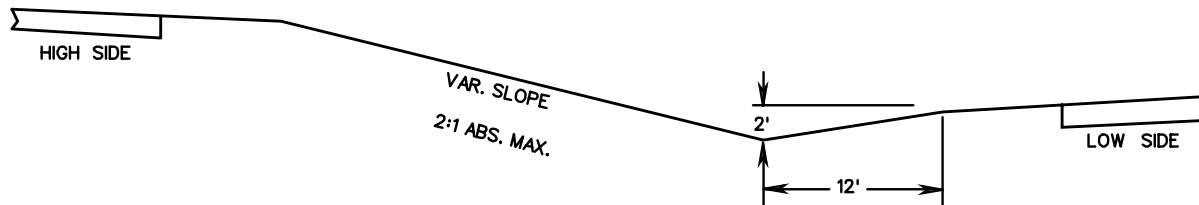

HOLD A 2' DITCH DEPTH, 12' WIDE, ADJACENT TO LOWER SHOULDER.



ROAD AND BRIDGE STANDARDS

SHEET 1 OF 1

REVISION DATE

702.04

STANDARD GRADED MEDIAN DESIGNS

VIRGINIA DEPARTMENT OF TRANSPORTATION

SPECIFICATION
REFERENCE

APPENDIX

THIS PAGE INTENTIONALLY LEFT BLANK



ROAD AND BRIDGE STANDARDS

SHEET 1 OF 1

REVISION DATE

SPECIFICATION
REFERENCE

VIRGINIA DEPARTMENT OF TRANSPORTATION

INCHES AND FRACTIONS OF AN INCH IN DECIMALS OF A FOOT

INCHES	0	1/16	1/8	3/16	1/4	5/16	3/8	7/16	1/2	9/16	5/8	11/16	3/4	13/16	7/8	15/16
0	.0000	.0052	.0104	.0156	.0208	.0260	.0313	.0365	.0417	.0469	.0521	.0573	.0625	.0677	.0729	.0781
1	.0833	.0885	.0938	.0990	.1042	.1094	.1146	.1198	.1250	.1302	.1354	.1406	.1458	.1510	.1563	.1615
2	.1667	.1719	.1771	.1823	.1875	.1927	.1979	.2031	.2083	.2135	.2188	.2240	.2292	.2344	.2396	.2448
3	.2500	.2552	.2604	.2656	.2708	.2760	.2813	.2865	.2917	.2969	.3021	.3073	.3125	.3177	.3229	.3281
4	.3333	.3385	.3438	.3490	.3542	.3594	.3646	.3698	.3750	.3803	.3854	.3906	.3958	.4010	.4063	.4115
5	.4167	.4219	.4271	.4323	.4375	.4427	.4479	.4531	.4583	.4635	.4688	.4740	.4792	.4844	.4896	.4948
6	.5000	.5052	.5104	.5156	.5208	.5260	.5313	.5365	.5417	.5469	.5521	.5573	.5625	.5677	.5729	.5781
7	.5833	.5885	.5938	.5990	.6042	.6094	.6146	.6198	.6250	.6302	.6354	.6406	.6458	.6510	.6563	.6615
8	.6667	.6719	.6771	.6823	.6875	.6927	.6979	.7031	.7083	.7135	.7188	.7240	.7292	.7344	.7396	.7448
9	.7500	.7552	.7604	.7656	.7708	.7760	.7813	.7865	.7917	.7969	.8021	.8073	.8125	.8177	.8229	.8281
10	.8333	.8385	.8438	.8490	.8542	.8594	.8646	.8698	.8750	.8802	.8854	.8906	.8958	.9010	.9063	.9115
11	.9167	.9219	.9271	.9323	.9375	.9427	.9479	.9531	.9583	.9635	.9688	.9740	.9792	.9844	.9896	.9948

SPECIFICATION REFERENCE	<h2>CONVERSION TABLES</h2> <p>VIRGINIA DEPARTMENT OF TRANSPORTATION</p>	 ROAD AND BRIDGE STANDARDS	
		REVISION DATE	SHEET 1 OF 1 A-1

BAR SIZES		WEIGHT POUNDS PER FOOT	NOMINAL DIMENSIONS ROUND SECTIONS		
DIAMETER	DESIGNATION		DIAMETER INCHES	CROSS SECTIONAL SQ. INCHES	PERIMETER INCHES
1/4	2	.167	.250	.05	.786
3/8	3	.376	.375	.11	1.178
1/2	4	.668	.500	.20	1.571
5/8	5	1.043	.625	.31	1.963
3/4	6	1.502	.750	.44	2.356
13/16	7	2.044	.875	.60	2.749
1	8	2.670	1.000	.79	3.142
1 1/8	9	3.400	1.128	1.00	3.544
1 1/4	10	4.303	1.270	1.27	3.990
1 5/8	11	5.313	1.410	1.56	4.430

NOTE:

BAR NUMBERS ARE BASED ON THE NUMBER OF 1/8 INCHES INCLUDED IN THE NOMINAL DIAMETER OF THE BAR.

BAR NO. 2 IN PLAIN ROUNDS ONLY.



ROAD AND BRIDGE STANDARDS

STANDARD REINFORCING BARS

SPECIFICATION
REFERENCE

SHEET 1 OF 1

REVISION DATE

A-2

VIRGINIA DEPARTMENT OF TRANSPORTATION

PARABOLIC VERTICAL CURVE

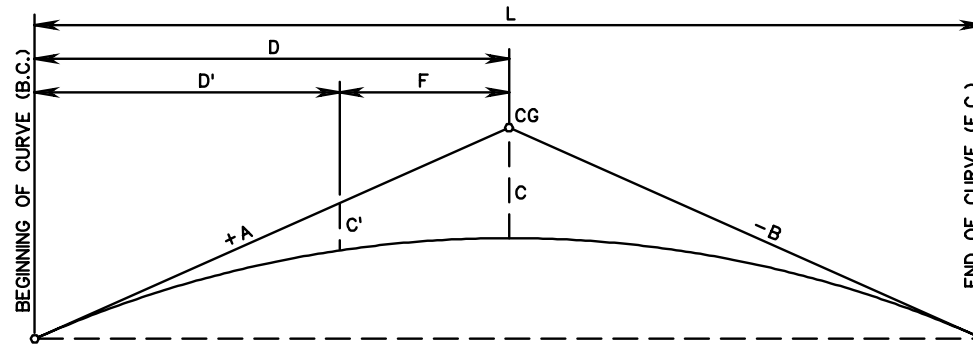

C.G.=POINT OF CHANGE OF GRADIENT

C = CENTER CORRECTION

C' = CORRECTION AT ANY GIVEN POINT ON CURVE

D = $L/2$ = HALF LENGTH OF VERTICAL CURVE

D' = DISTANCE TO POINT WHERE CORRECTION IS REQUIRED FROM BEGINNING OR END OF CURVE

$$C = \frac{\text{ALG. DIFF. X LENGTH OF CURVE IN STATIONS}}{8}$$

$$C' = C \left(\frac{D'}{D} \right)^2$$

SPECIFICATION
REFERENCE

PARABOLIC VERTICAL CURVE COMPUTATIONS

VIRGINIA DEPARTMENT OF TRANSPORTATION

VDOT

ROAD AND BRIDGE STANDARDS

REVISION DATE

SHEET 1 OF 1

A-3

TO CONVERT FROM	TO	MULTIPLY BY	TO CONVERT FROM	TO	MULTIPLY BY
<u>LENGTH</u>			<u>VELOCITY</u>		
INCH (in)	METER (m)	.0254	FOOT/SECOND	METER/SECOND (m/s)	.3048
FOOT (ft)	METER (m)	.3048	MILE/HOUR (U.S. STATUTE)	METER/SECOND (m/s)	.4470
YARD (yd)	METER (m)	.9144	MILE/HOUR (U.S. STATUTE)	KILOMETER/HOUR	1.6093
MILE (U.S. STATUTE)	METER (m)	1609.3440	<u>TEMPERATURE</u>		
<u>AREA</u>			DEGREE FAHRENHEIT	DEGREE CELSIUS	$t^{\circ}c = (t^{\circ}F - 32)/1.8$
INCH ² (in ²)	METER ² (m ²)	.0006	<u>OTHER COMMONLY USED UNITS</u>		
FOOT ² (ft ²)	METER ² (m ²)	.0929	MILLIMETER	- 0.001 METER	
YARD ² (yd ²)	METER ² (m ²)	.8361	CENTIMETER	- 0.01 METER	
MILE ² (U.S. STATUTE)	METER ² (m ²)	2589988.0000	KILOMETER	- 1000 METER	
ACRES	METER ² (m ²)	4046.8560	KILOGRAM	- 1000 GRAMS	
<u>MASS</u>			MILLILITER	- 0.001 LITER	
TON (SHORT-2000 lbs)	KILOGRAM (kg)	907.1847			
<u>VOLUME</u>					
FOOT ³ (ft ³)	METER ³ (m ³)	.0283			
YARD ³ (yd ³)	METER ³ (m ³)	.7645			
ACRE-FOOT	METER ³ (m ³)	1233.4820			
OUNCE (U.S. LIQUID)	LITER (l)	.0296			
PINT (U.S. LIQUID)	LITER (l)	.4732			
QUART (U.S. LIQUID)	LITER (l)	.9463			
GALLON (U.S. LIQUID)	LITER (l)	3.7853			



ROAD AND BRIDGE STANDARDS

METRIC CONVERSION FACTORS

SPECIFICATION
REFERENCE

SHEET 1 OF 1

REVISION DATE

A-4

VIRGINIA DEPARTMENT OF TRANSPORTATION