

5/8" THREADED ROD WITH NUT AND LOCK WASHER ON EACH END. CUT ROD FLUSH WITH NUT ON TRAFFIC SIDE.

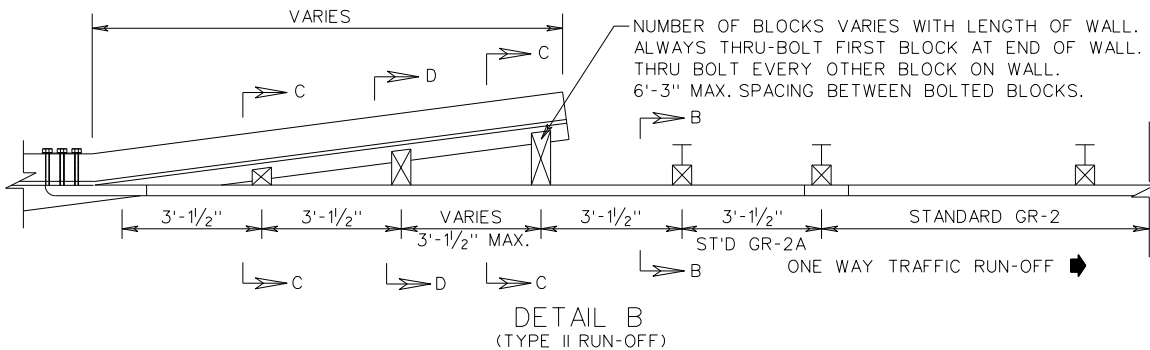
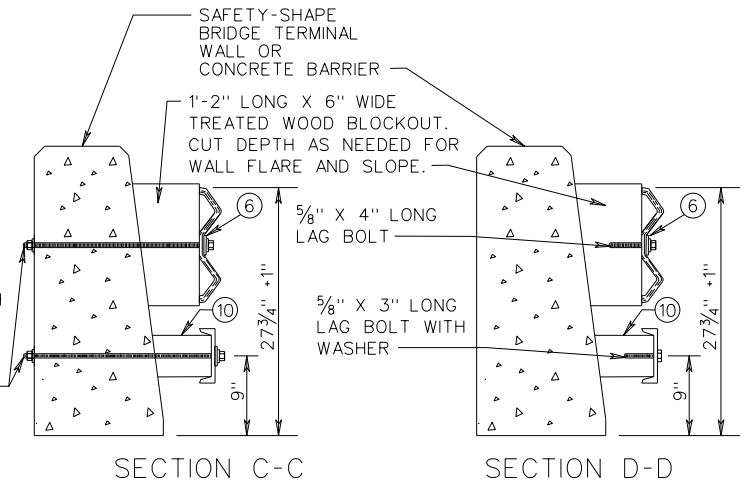

GR-FOA-3 W-BEAM GUARDRAIL INSTALLATION CRITERIA
FIXED OBJECT ATTACHMENT METHODS WITH RUBRAIL AND HARDWARE DETAILS
A COPY OF THE SEALED AND SIGNED DRAWING IS ON FILE IN THE CENTRAL OFFICE.

VDOT
VIRGINIA DEPARTMENT
OF
TRANSPORTATION

REVISION DATE	SPECIAL DESIGN SECTION DRAWING NO.	SHEET 2 OF 3
01/14	ISA47	