

SECTION A-A

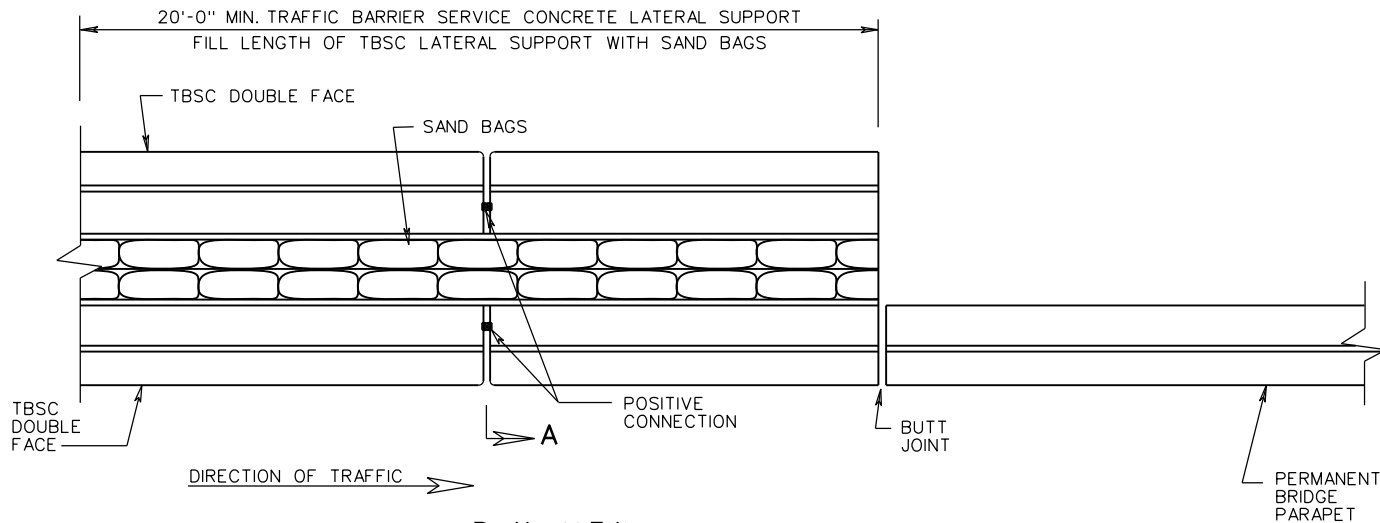

NOTES:

1. BASIS OF PAYMENT:
TRAFFIC BARRIER SERVICE LATERAL SUPPORT WILL BE MEASURED AND PAID FOR IN UNITS OF EACH COMPLETE IN PLACE AND SHALL INCLUDE FURNISHING AND PLACING PRECAST CONCRETE BARRIERS (TBS CONCRETE) AND SAND BAGS, MAINTENANCE, REMOVAL WHEN NO LONGER NECESSARY, AND ALL MATERIALS, LABOR, TOOLS, EQUIPMENTS, AND INCIDENTALS NECESSARY TO COMPLETE THE WORK.
2. FOR POSITIVE CONNECTION DETAILS AND DIMENSIONS SEE STANDARD MB-INS, SHEETS 502.20 - 502.22
3. FOR DIMENSIONS NOT SHOWN, REFER TO ST'D. MB-7D AND MB-10A.



PLAN VIEW
METHOD B

SPECIFICATION
REFERENCE

A COPY OF THE ORIGINAL SEALED AND SIGNED DRAWING IS ON FILE IN THE CENTRAL OFFICE.

**BUTTING TRAFFIC BARRIER SERVICE
TO SINGLE FACE PARAPET SERVICE**

VIRGINIA DEPARTMENT OF TRANSPORTATION



ROAD AND BRIDGE STANDARDS

REVISION DATE

SHEET 5 OF 5

7/11

502.24