

POST CLAMP DETAIL

FASTENING

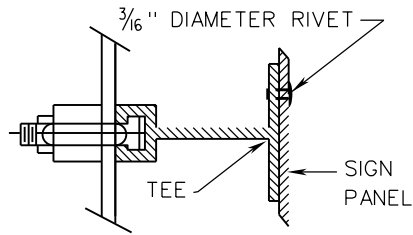

RIVETS SHALL BE DOME HEAD, BREAK MANDREL, BLIND RIVETS CONFORMING TO INDUSTRIAL FASTENERS INSTITUTE STANDARD IFI-114, STYLE 1, GRADES 10 OR 11 EXCEPT THAT THE MINIMUM ULTIMATE TENSILE STRENGTH SHALL BE 360 POUNDS. RIVETS SHALL HAVE A GRIP RANGE ACCOMMODATING THE COMBINED THICKNESS OF THE SIGN PANEL AND ZEE BAR AND SHALL BE INSTALLED IN ACCORDANCE WITH THE MANUFACTURER'S RECOMMENDATIONS.

CENTERLINE HOLE FOR 3/8" DIAMETER SQUARE HEAD STAINLESS STEEL BOLT x 2 1/4" LONG WITH SELF-LOCKING NUT AND ONE FLAT WASHER.

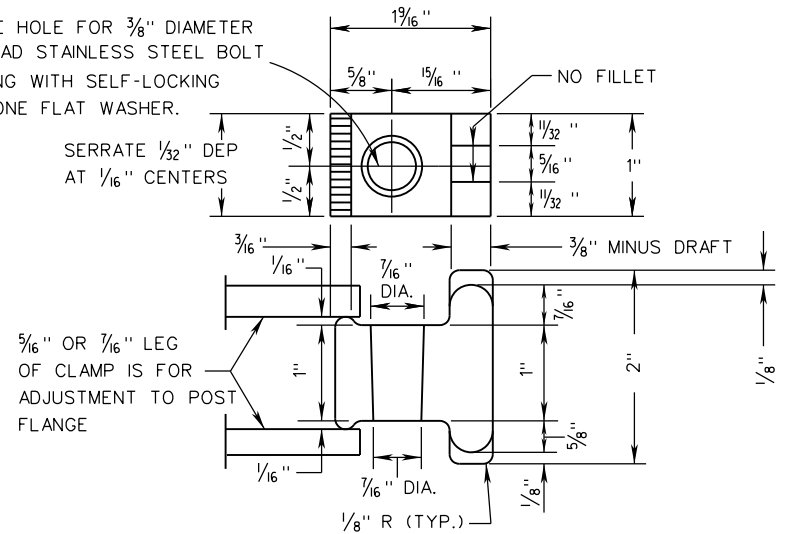

TEE BAR SPACING CHART

STRUCTURE TYPE	SIGN PANEL DIMENSIONS				TEE 6061-T6 2.5 x 3.0 @ 1.175 LB/FT.		
	W	H	c	d	NUMBER	LENGTH	CLAMP
VA-A	3'	3'	1'-3"	5/8"	-	-	-
VA-B	4'	4'	1'-2"	1'-8"	2	3'-0"	4
VA-C	4'	5'	1'-3"	2'-6"	2	3'-0"	4
VA-D	5'	3'	0'-8"	1'-8"	2	4'-0"	4
VA-E	6'	5'	1'-3"	2'-6"	2	5'-0"	4
VA-F	4'	-	1'-8"	2'-4"	2	2'-10"	4
VA-G	5'	-	1'-8"	-	1 EACH	2'-10" & 1'-4"	4
VA-K	4'	5'	1'-3"	2'-6"	2	3'-0"	4
VA-K	4'	4'	1'-2"	1'-8"	2	3'-0"	4
VA-L	6'	6'	1'-6"	3'-0"	2	5'-0"	4
VA-M	5'	5'	1'-3"	2'-6"	2	4'-0"	4
VA-A2	6'	3'	-	-	4	5'-0"	-
VA-N	7'	7'	1'-0"	2'-6"	3	6'-0"	6
VA-O	13'	5'	1'-3"	2'-6"	2	4'-0"	4

TEE CROSS SECTION

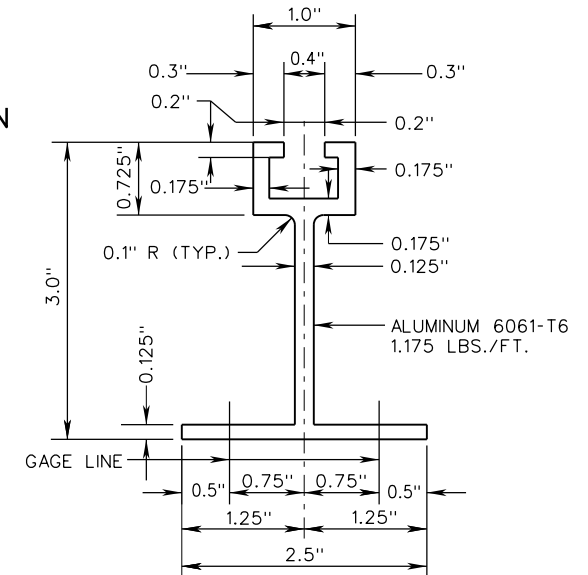

SPECIFICATION REFERENCE

701

A COPY OF THE ORIGINAL SEALED AND SIGNED DRAWING IS ON FILE IN THE CENTRAL OFFICE.

SIGN PANEL DESIGN

VIRGINIA DEPARTMENT OF TRANSPORTATION

VDOT

ROAD AND BRIDGE STANDARDS

REVISION DATE

01/15

SHEET 2 OF 2

1325.41