

7/8" \varnothing H.S. BOLT & HEX NUT (A325), OR 7/8" \varnothing DOUBLE ENDED THREADED ROD & HEX NUT (A-193 GR. B7).
 3/2" x 3/2" x 1/2" SQUARE WASHER (A36 OR A572) WITH 15/16" \varnothing HOLE.
 AT THE DISCRETION OF THE ENGINEER, A LARGER WASHER SIZE MAY BE REQUIRED IF SPALLING IS EVIDENT AT BOTTOM OF DECK. TO PREVENT OR MINIMIZE SPALLING, PREDRILLING A PILOT HOLE USING A SMALLER DIAMETER DRILL BIT IS REQUIRED.

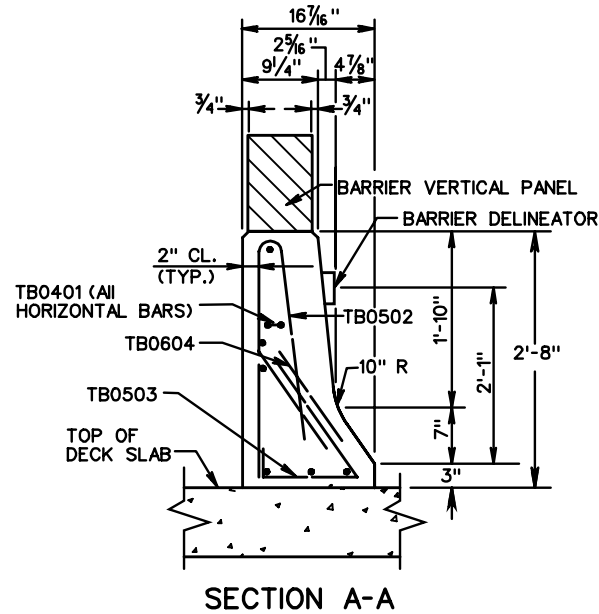

SECTION A-A

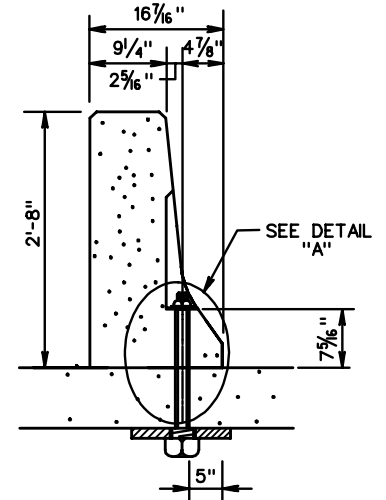

SECTION B-B
 (ANCHOR BOLT)
 BOLT DOWN SIDE ADJACENT TO TRAFFIC

DETAIL "A" NOTES:

1. BARRIER DELINEATOR TO BE SPACED IN ACCORDANCE WITH SECTION 702, OF THE ROAD AND BRIDGE SPECIFICATIONS AND THE BARRIER VERTICAL PANELS TO BE SPACED IN ACCORDANCE WITH VIRGINIA WORK AREA PROTECTION MANUAL. REFLECTIVE SURFACE, IN ALL INSTANCES, TO BE FACING ONCOMING TRAFFIC.
2. CONCRETE 4000 PSI(MIN.). REINFORCING STEEL GRADE 60.
3. AFTER REMOVING TEMPORARY BARRIER, CUT 7/8" \varnothing BOLT OR THREADED ROD AS LOW AS PRACTICAL BELOW ROADWAY SURFACE AND FILL RECESS WITH EPOXY BONDING COMPOUND EP-4 (DETAIL "A") OR REMOVE 7/8" \varnothing BOLTS OR THREADED RODS AND FILL HOLES WITH GROUT BONDED WITH EPOXY BONDING COMPOUND EP-4 (DETAIL "A").
4. COST OF BARRIER DELINEATOR AND BARRIER VERTICAL PANELS TO BE INCLUDED IN PRICE BID PER LINEAR FOOT OF BARRIER SERVICE.
5. WHEN BARRIER IS LOCATED ON VERTICAL AND/OR HORIZONTAL CURVES, THE OPENING AT THE JOINT IS NOT TO EXCEED 1".
6. DESIGN FEATURES RELATING TO CONSTRUCTION OR TO REGULATION AND CONTROL OF TRAFFIC MAY BE SUBJECT TO CHANGE AS DEEMED NECESSARY BY THE DEPARTMENT.
7. FOR POSITIVE CONNECTION DETAILS AND DIMENSIONS SEE STANDARD SHEETS 502.20 - 502.24.

SPECIFICATION REFERENCE

TRAFFIC BARRIER SERVICE CONCRETE PARAPET
 (SINGLE FACE)

(FOR TEMPORARY INSTALLATION ON BRIDGE DECK EXTERIOR)

VIRGINIA DEPARTMENT OF TRANSPORTATION

VDOT

ROAD AND BRIDGE STANDARDS

REVISION DATE

SHEET 2 OF 2

502.12